



10219





MAERSK

1650



1970

1980

19



1651



1552

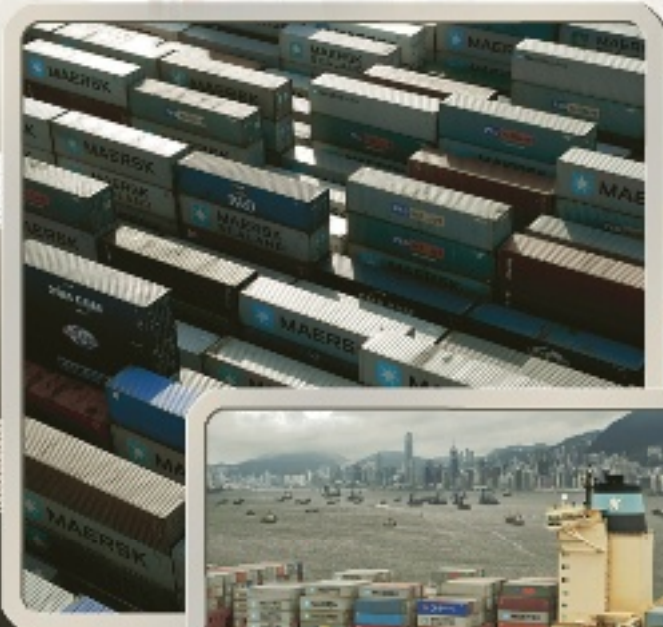

10152



10219



90

2000

2010



1831



10155



### A.P. MOLLER – MAERSK GROUP - The LEGO Group History

The relationship between The LEGO Group and A.P. MOLLER – MAERSK GROUP was founded on a personal relationship between Godtfred Kirk Christiansen and Mærsk Mc-Kinney Møller. The first Maersk promotional set was a Maersk Line container ship released in 1974. Now, more than 37 years later, 10219 Maersk Train is inspired by an actual train that transported containers across the United States.

2 million Maersk containers are currently in circulation worldwide. The white containers, or 'reefers', are different from the gray containers because they are refrigerated. One of the longest container trains ever was pulled by nine locomotives and stretched almost 3.5 miles in length!



### Geschichte A.P. MOLLER – MAERSK GROUP - der LEGO™ Gruppe

Die Kooperation zwischen der LEGO™ Gruppe und A.P. MOLLER – MAERSK GROUP gründet auf der Freundschaft zwischen Godtfred Kirk Christiansen und Mærsk Mc-Kinney Møller. Das erste Maersk Promotionset war ein Maersk Line Containerschiff, das 1974 auf den Markt kam. Heute, über 37 Jahre später, ist es der 10219 Maersk Zug von einem echten Zug inspiriert, der Container quer durch die Vereinigten Staaten transportierte.

2 Millionen Maersk Container sind derzeit weltweit auf Schienen unterwegs. Der Unterschied zwischen den weißen und den grauen Containern ist, dass die weißen gekühlt sind. Einer der längsten Containerzüge, den es jemals gab, wurde von neun Lokomotiven gezogen und war 5,6 km lang!



# MAERSK

1650



1970

1980

19



1651



1552



### A A.P. MOLLER – MAERSK GROUP - LEGO Csoport története

A LEGO Csoport és a A.P. MOLLER – MAERSK GROUP közötti kapcsolatot két ember, Godtfred Kirk Christiansen és Mærsk Mc-Kinney Møller személyes kapcsolatával kezdődött. Az első Maersk promóciós készlet egy Maersk Line konténerhajó volt, amely 1974-ben jelent meg. Most, több mint 37 évvel később, a 10219-es Maersk Train ötletét egy létező vonat adta, amely konténereket szállított az Egyesült Államokon keresztül.

Jelenleg 2 millió Maersk konténer van úton világszerte. A fehér konténerek vagy 'reefer'-ek mások, mint a szürkék, mert ezek hűtőkonténerek. A valaha volt egyik leghosszabb konténervonatot kilenc mozdony húzta, és több mint 5,6 kilométer hosszú volt!



### História da A.P. MOLLER – MAERSK GROUP - LEGO Group

A relação entre a LEGO Group e a A.P. MOLLER – MAERSK GROUP foi fundada com base numa relação pessoal entre Godtfred Kirk Christiansen e Mærsk Mc-Kinney Møller. O primeiro conjunto promocional Maersk foi um navio porta-contentores lançado em 1974. Agora, 37 anos mais tarde, o Comboio Maersk, modelo 10219, inspira-se num comboio autêntico que transportava contentores nos Estados Unidos.

2 milhões de contentores Maersk circulam actualmente no mundo. Os contentores brancos são diferentes dos contentores cinzentos porque são refrigerados. Um dos mais compridos comboios porta-contentores de sempre foi puxado por nove locomotivas e prolongava-se ao longo de quase 5,6 Km!

10152



10219



90

2000

2010



1831



10155



### Les origines de l'association entre A.P. MOLLER – MAERSK GROUP et le Groupe LEGO

L'association entre le Groupe LEGO et A.P. MOLLER – MAERSK GROUP est née de la relation personnelle entre Godtfred Kirk Christiansen et Mærsk Mc-Kinney Møller. Le premier ensemble promotionnel Maersk était un navire porte-conteneurs Maersk lancé en 1974. Aujourd'hui, 37 ans plus tard, le train Maersk, le modèle 10219, est inspiré d'un vrai train qui transportait des conteneurs aux États-Unis.

Deux millions de conteneurs Maersk sont actuellement en circulation dans le monde. Les conteneurs blancs sont différents des conteneurs gris car ils sont réfrigérés. L'un des trains transporteurs de conteneurs les plus longs était tiré par neuf locomotives et mesurait plus de 5,6 km de long !



### Historia de la relación entre A.P. MOLLER – MAERSK GROUP y el Grupo LEGO

La relación entre el Grupo LEGO y A.P. MOLLER – MAERSK GROUP tiene su origen en la amistad que mantenían Godtfred Kirk Christiansen y Mærsk Mc-Kinney Møller. El primer set promocional dedicado a Maersk fue un barco de mercancías de Maersk Line comercializado en 1974. Hoy, más de 37 años después, presentamos el set número 10219, Tren de Maersk, inspirado en un tren auténtico que transportaba contenedores a lo largo de Estados Unidos.

En la actualidad circulan alrededor del mundo un total de 2 millones de contenedores de Maersk. Los contenedores de color blanco se diferencian de los de color gris en que son de tipo refrigerado. ¡Uno de los trenes dedicados al transporte de contenedores más largo que ha existido contaba con nueve locomotoras y tenía una longitud de 5,6 kilómetros!

1

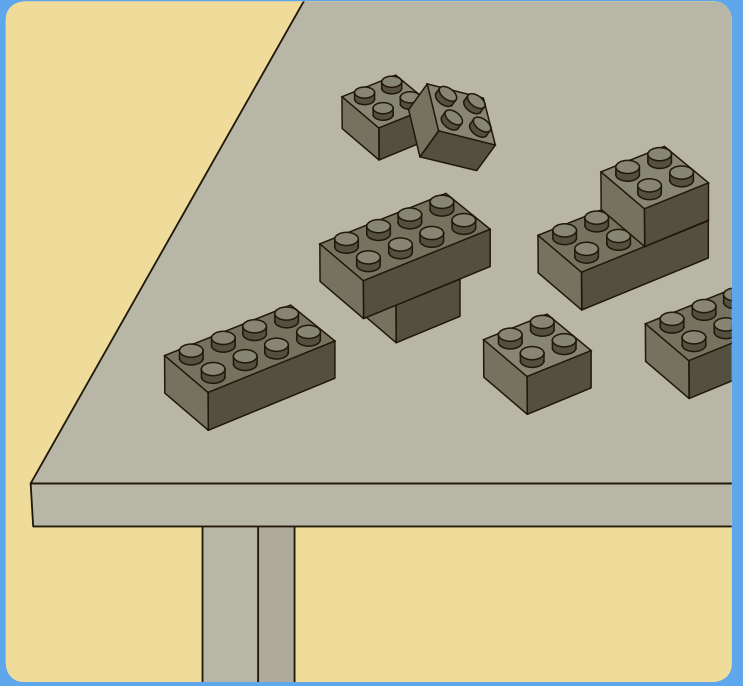
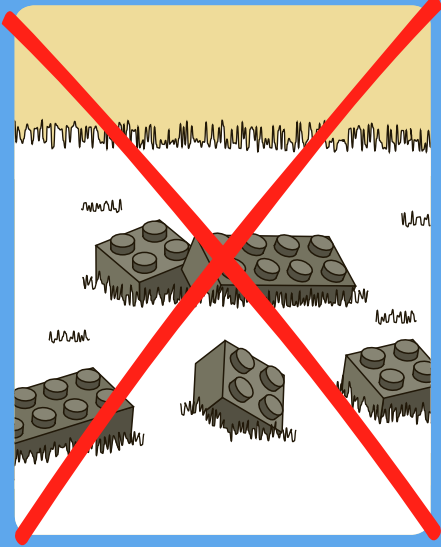

2





+

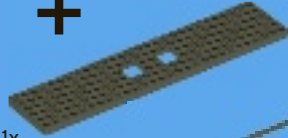

1x



4x



2x





2x

1



2x

2

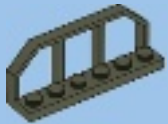

1x

3







4

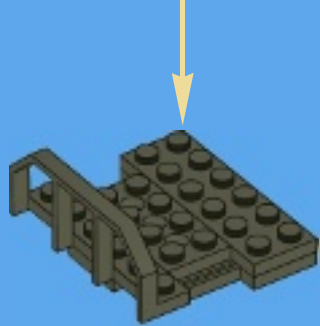
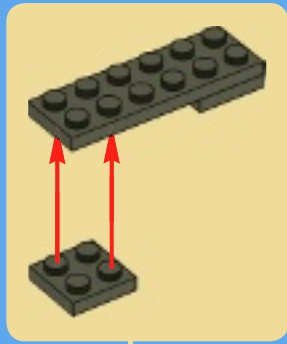

5





2x



2x

# 6

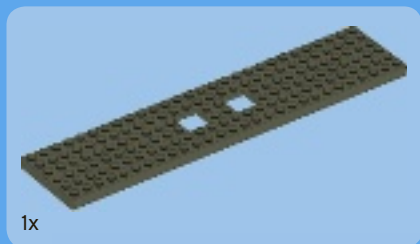
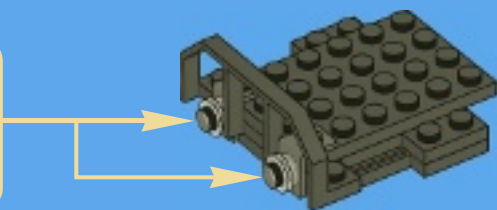
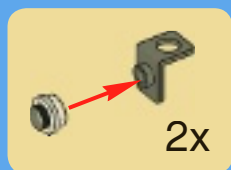

# 7

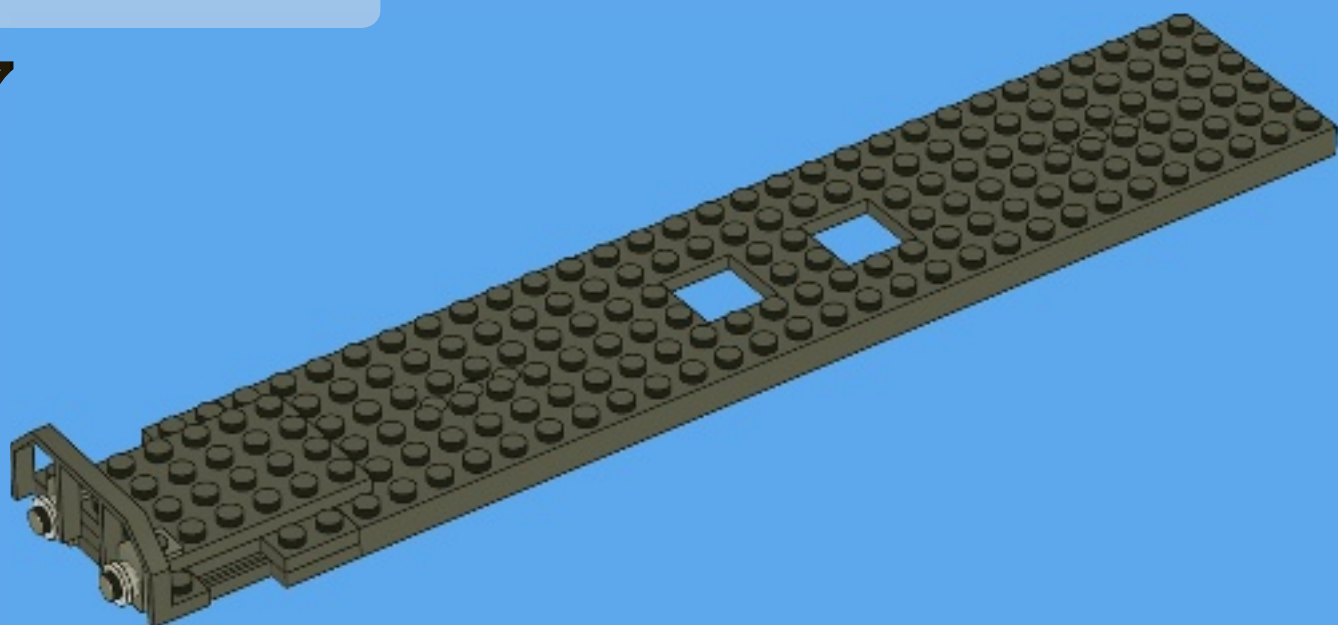



2x

1

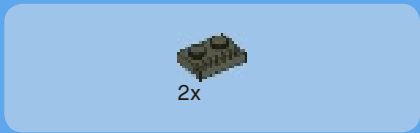

2x

2

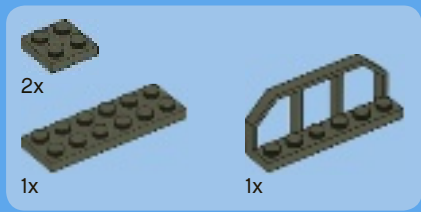

2x

1x

1x

3

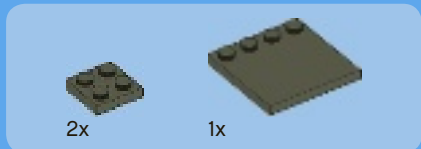
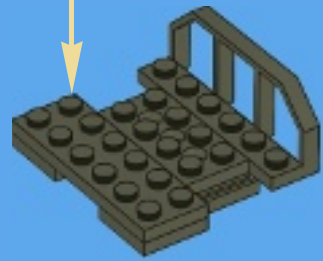
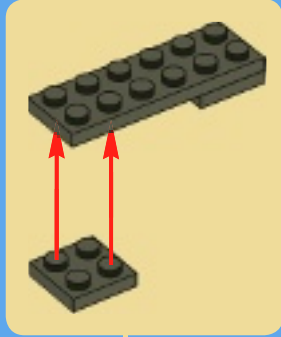

2x

1x

4

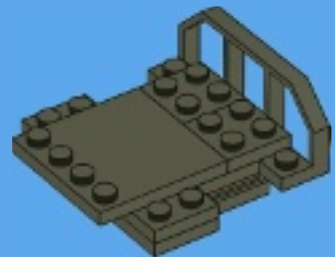



2x



2x

5

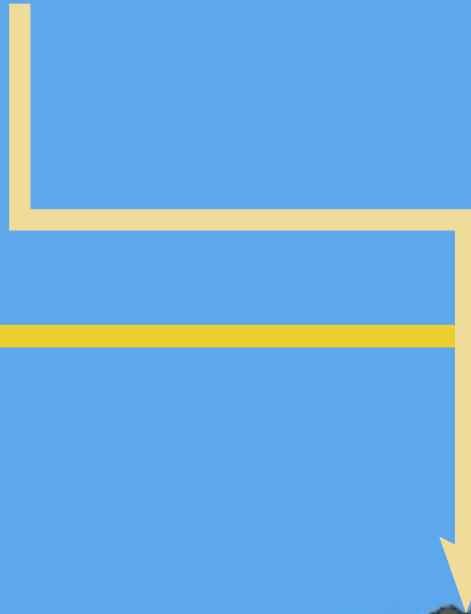
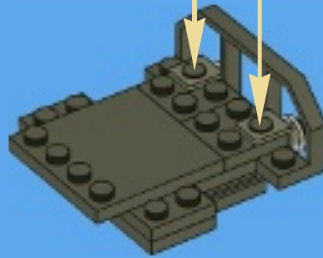

8

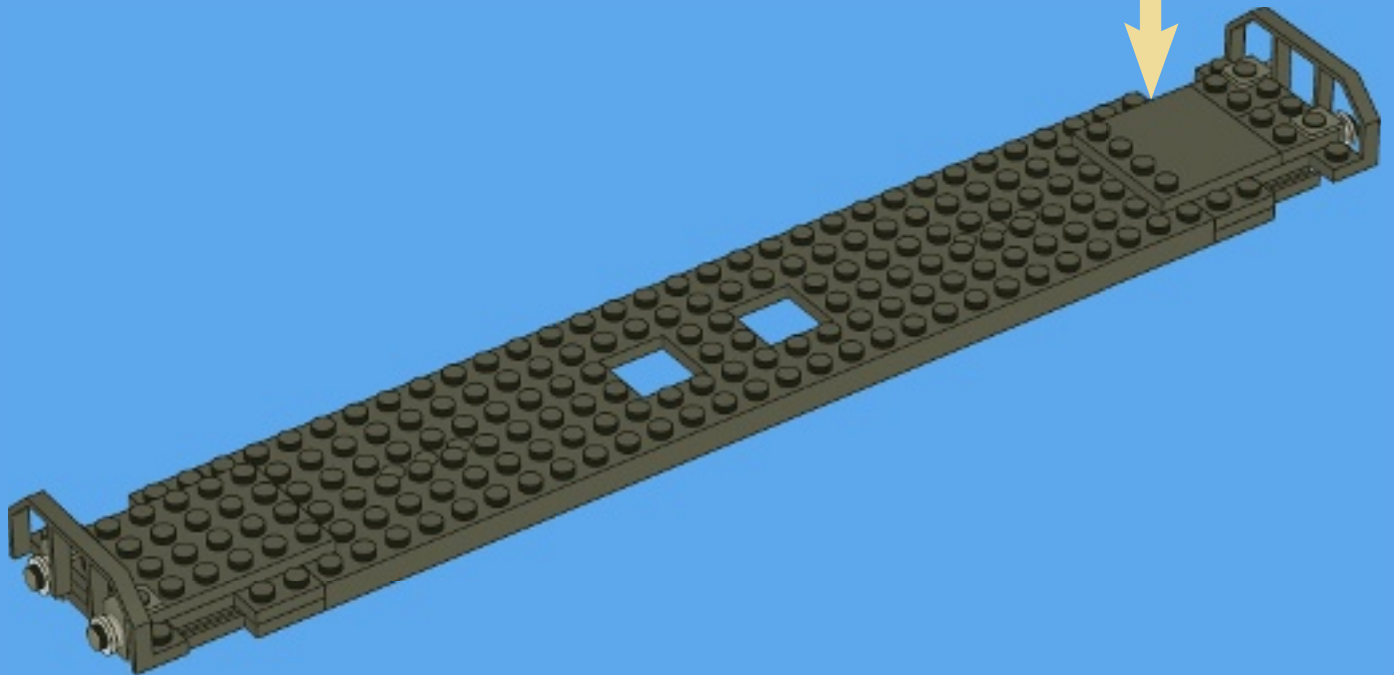

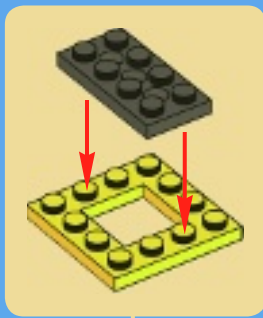
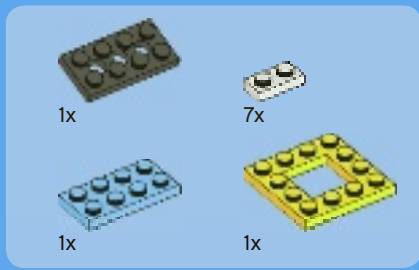

9

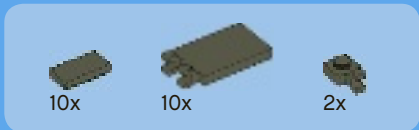
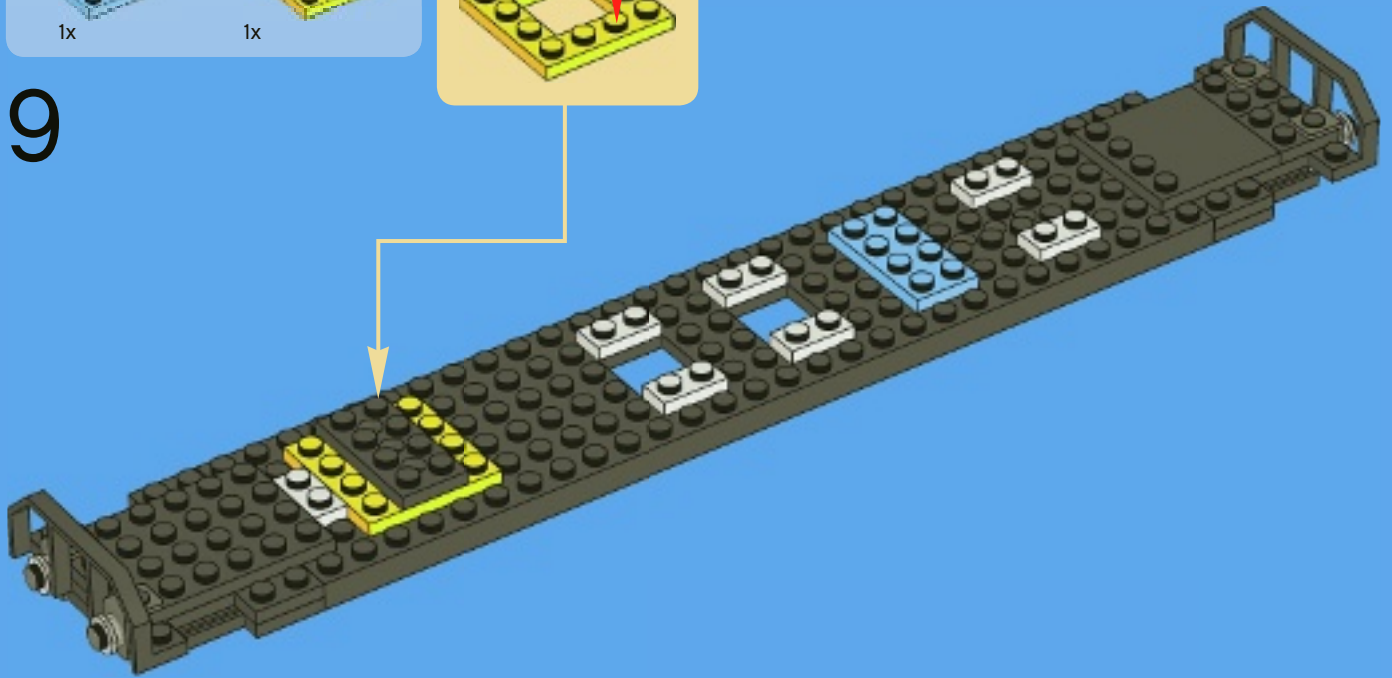

10

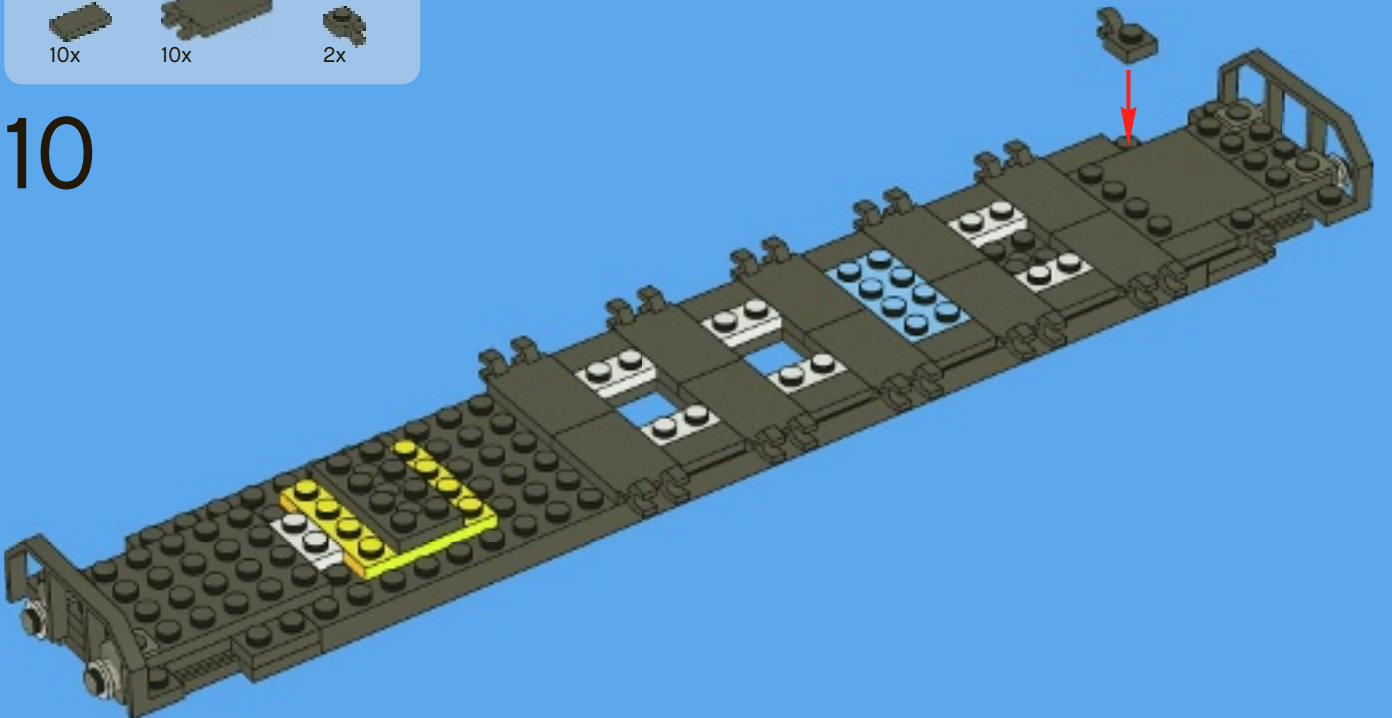

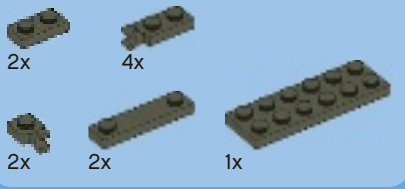

11

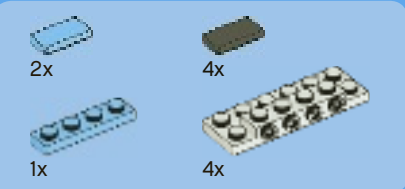
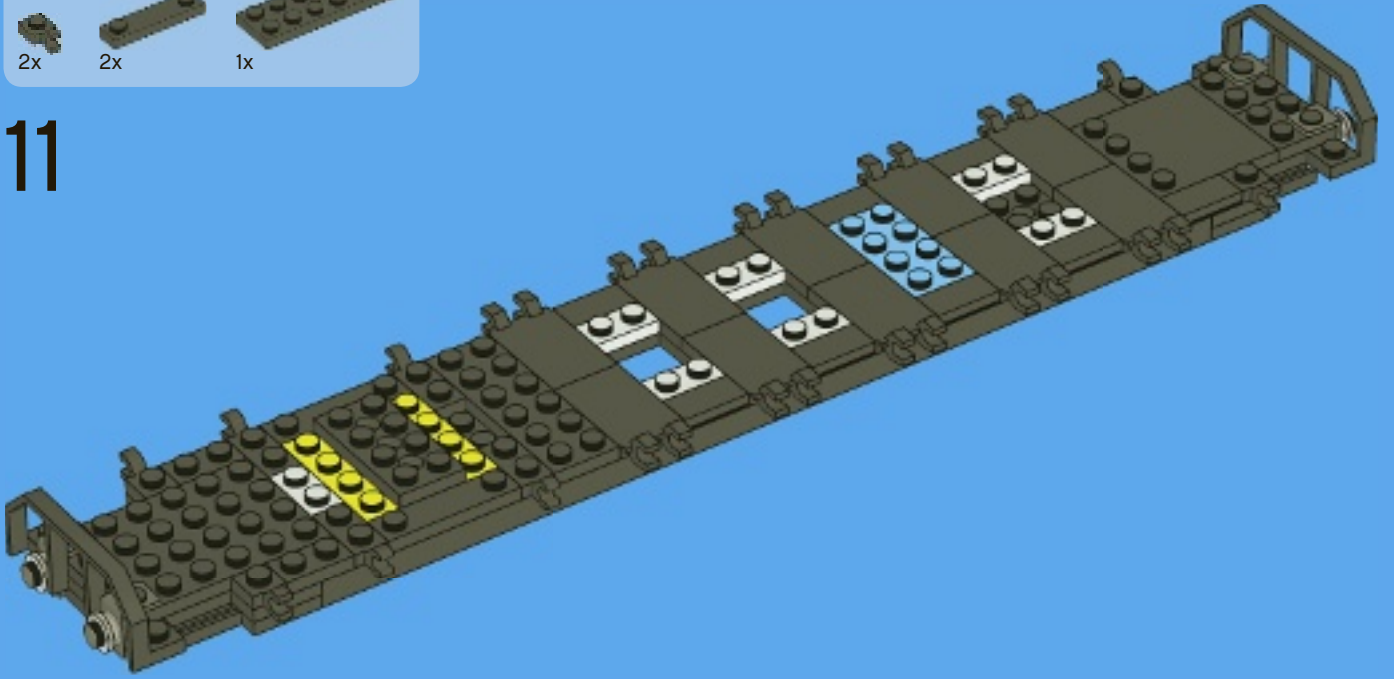

12

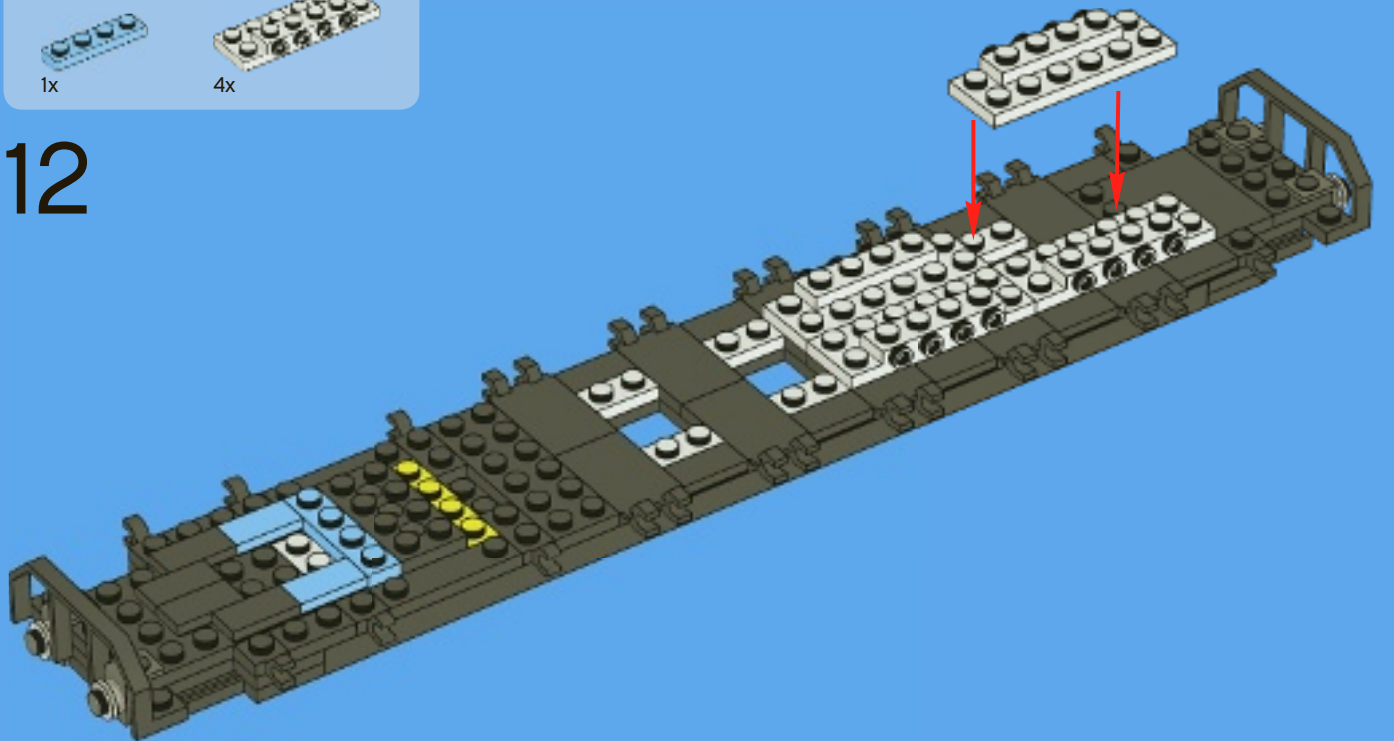



13

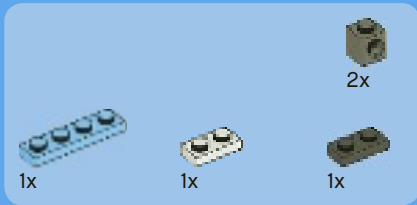
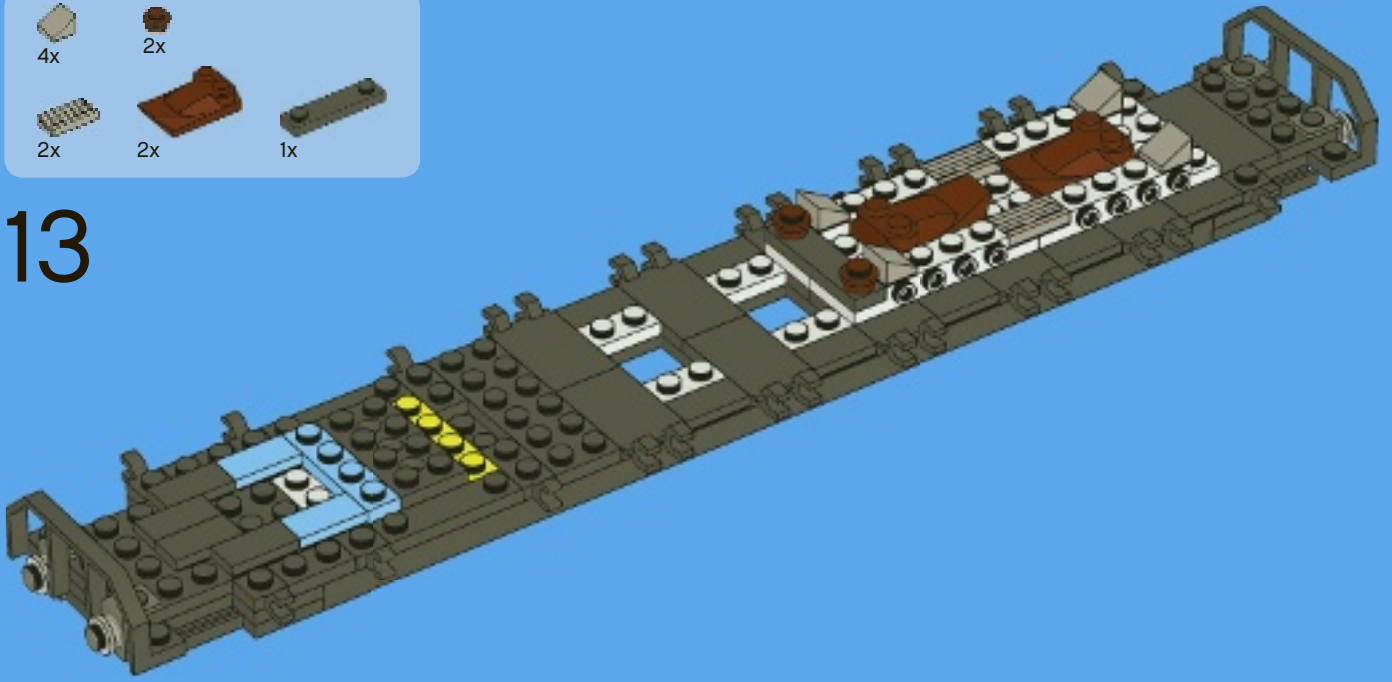

14

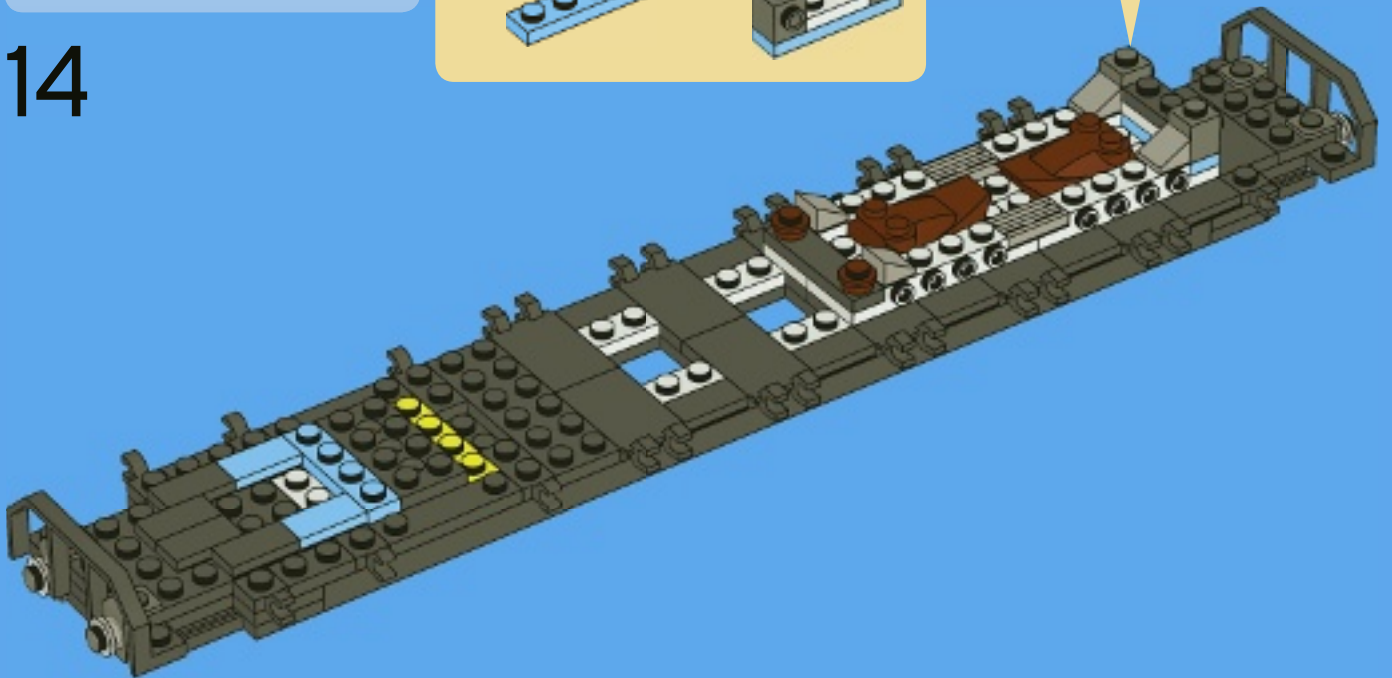
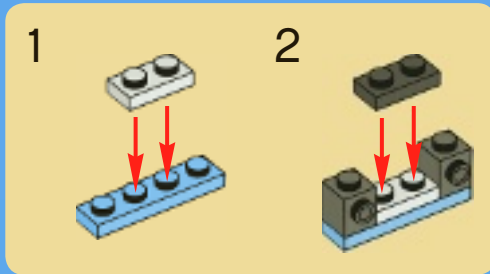

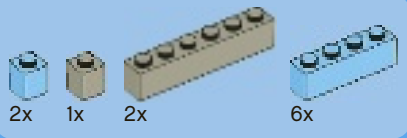

15

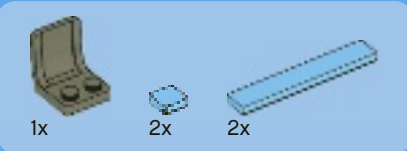
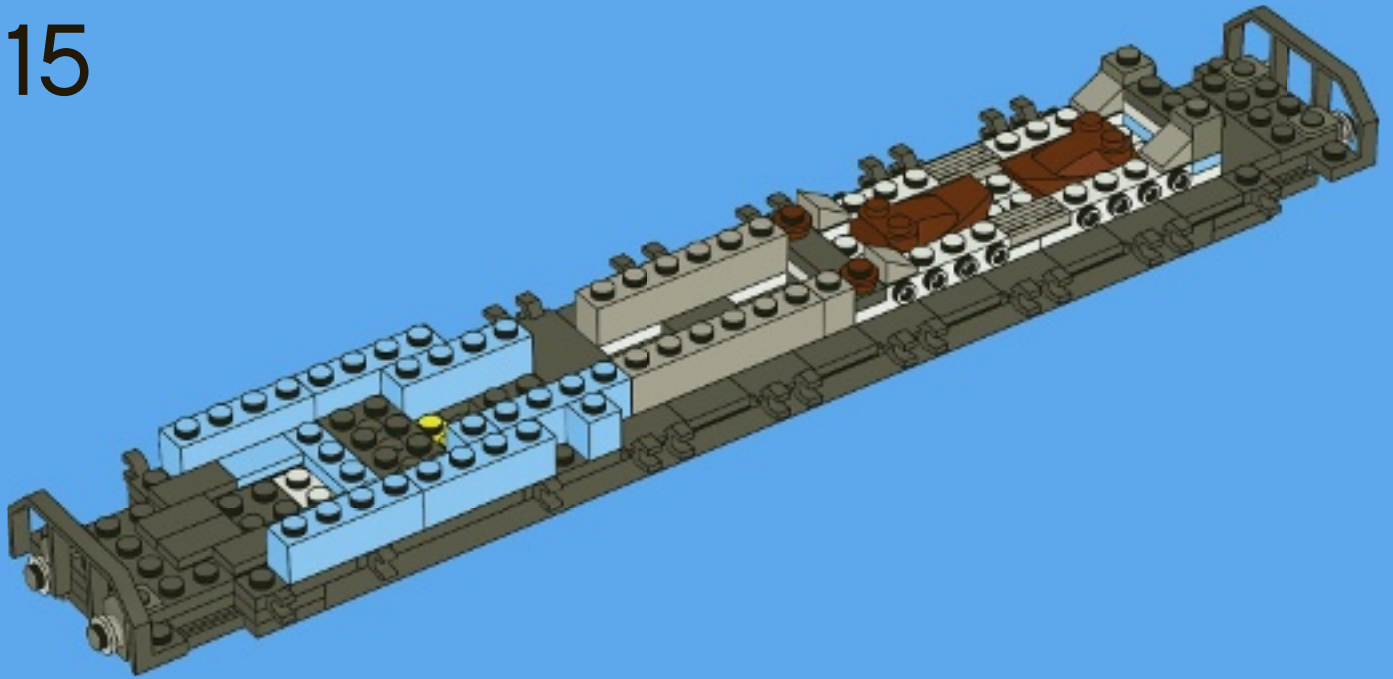

16

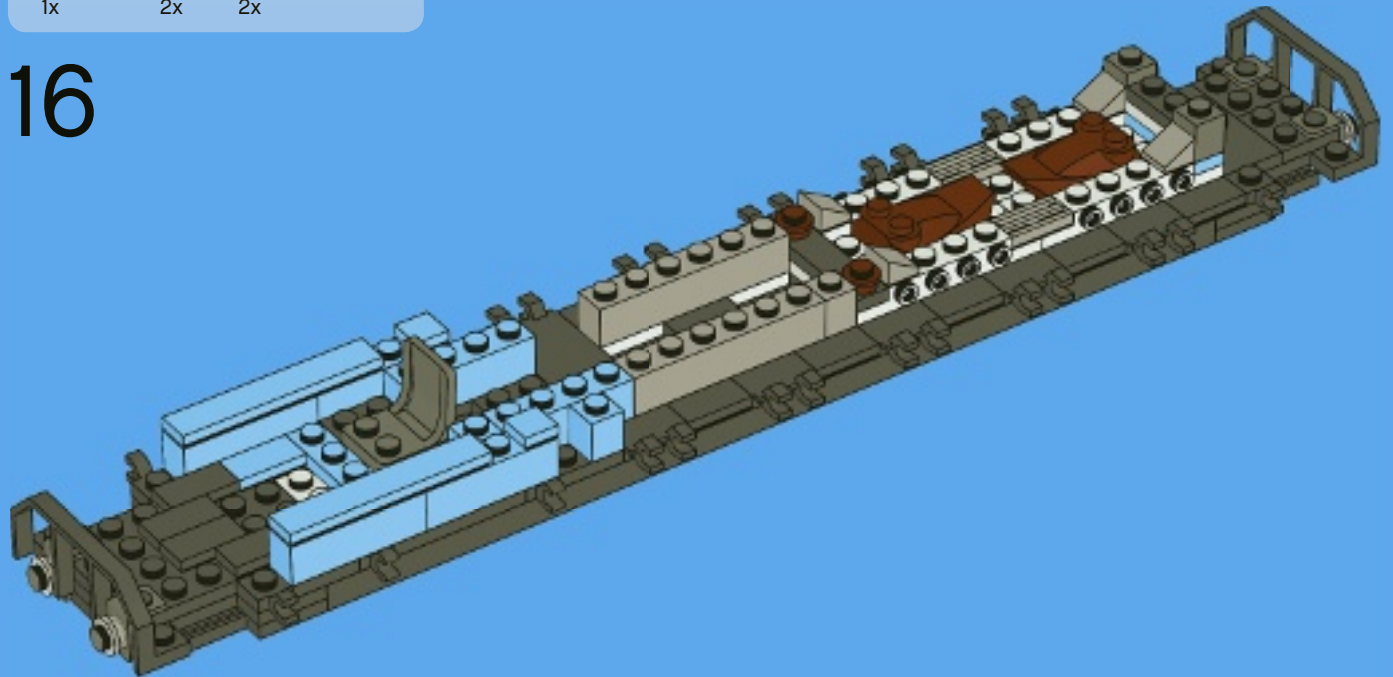



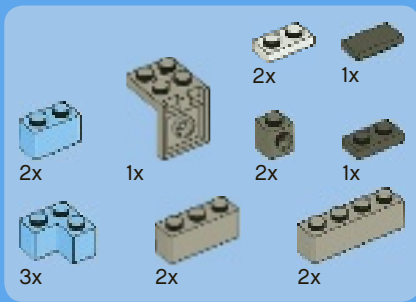

17

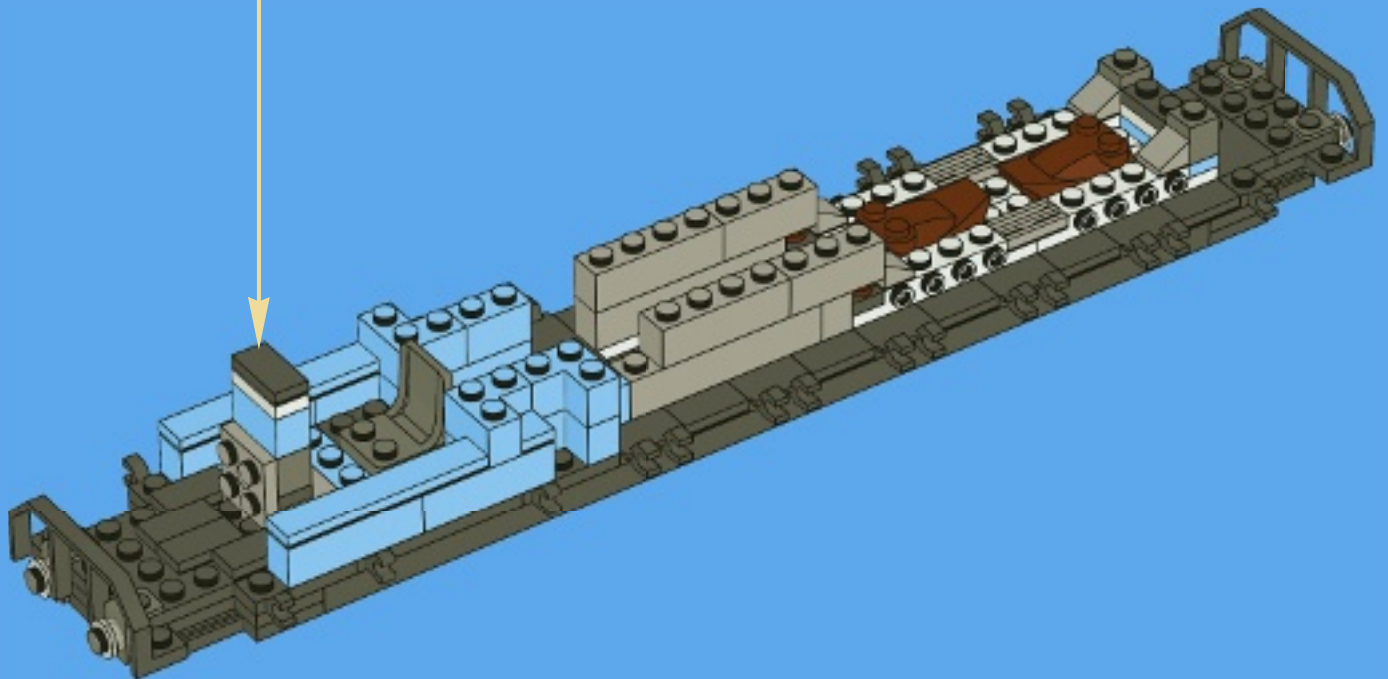
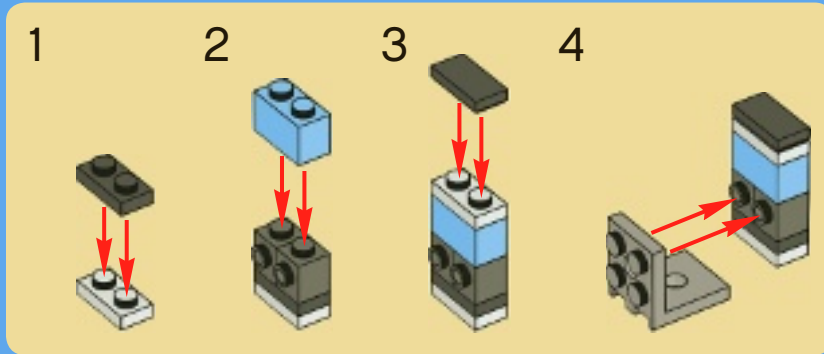

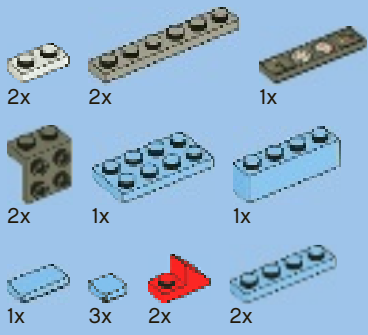

# 18

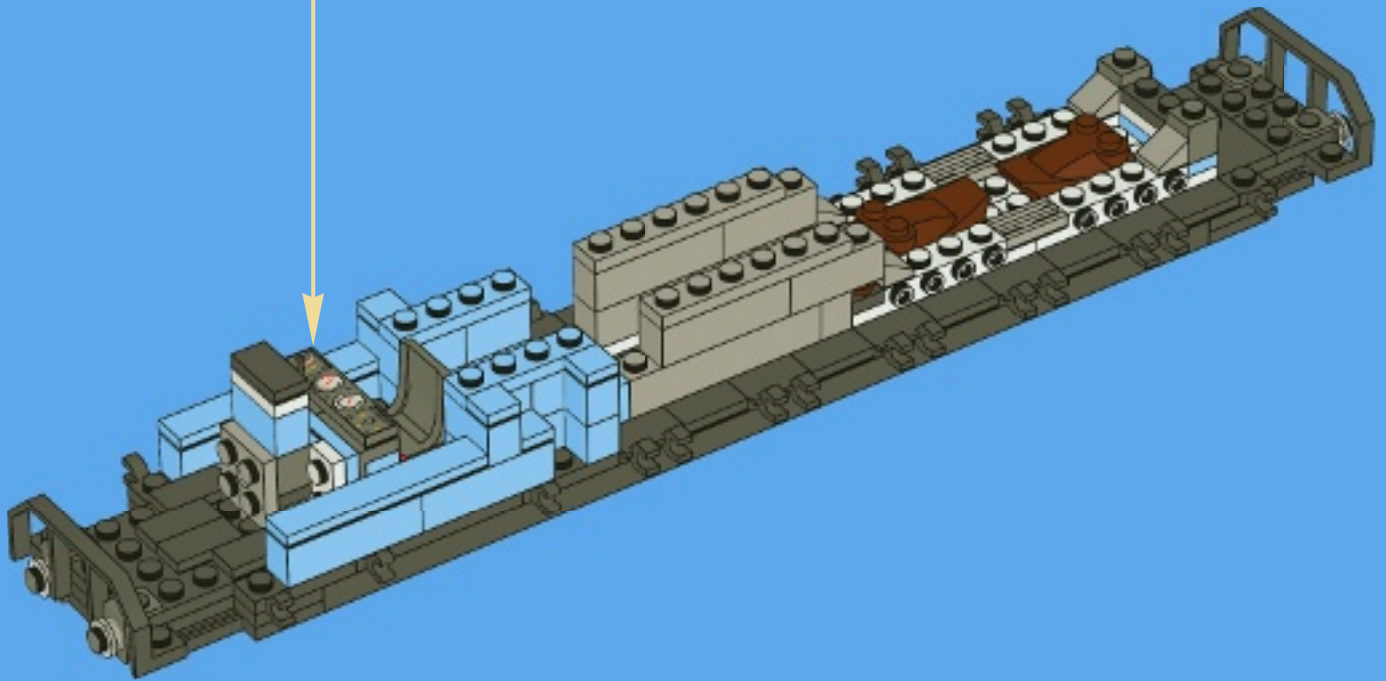
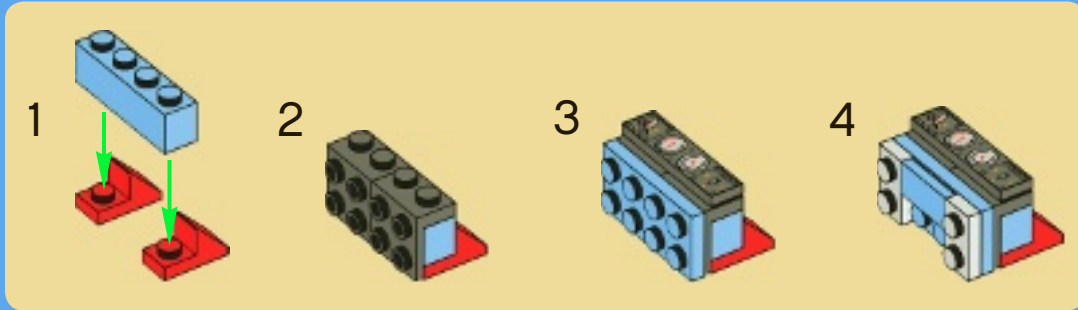

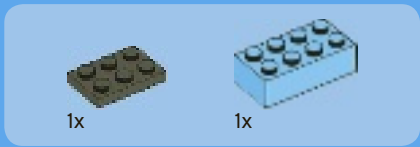

1



2

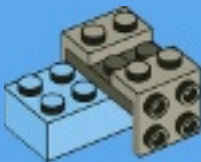

3

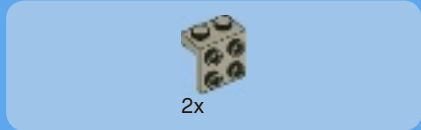
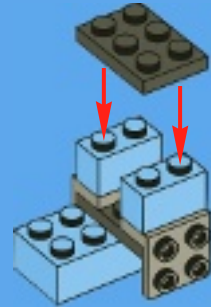

4

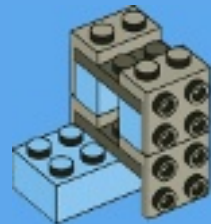



5

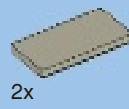
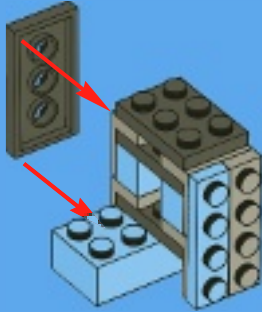

6

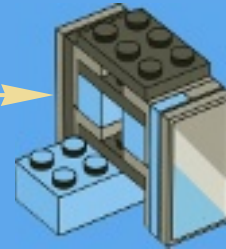
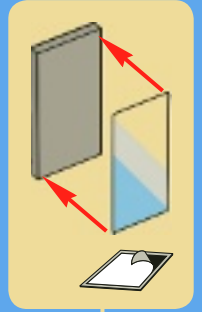
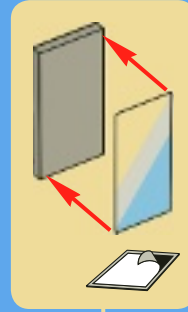

19

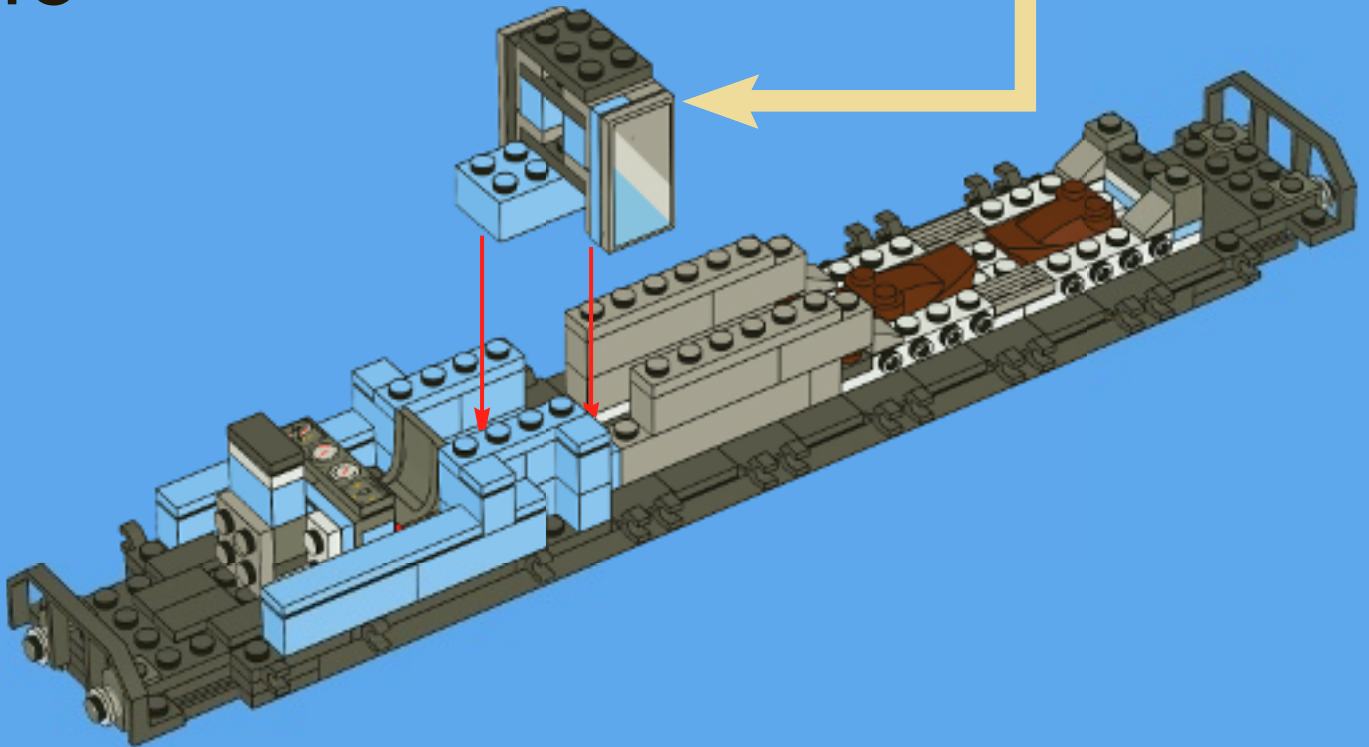



1x



1x



3x

# 20

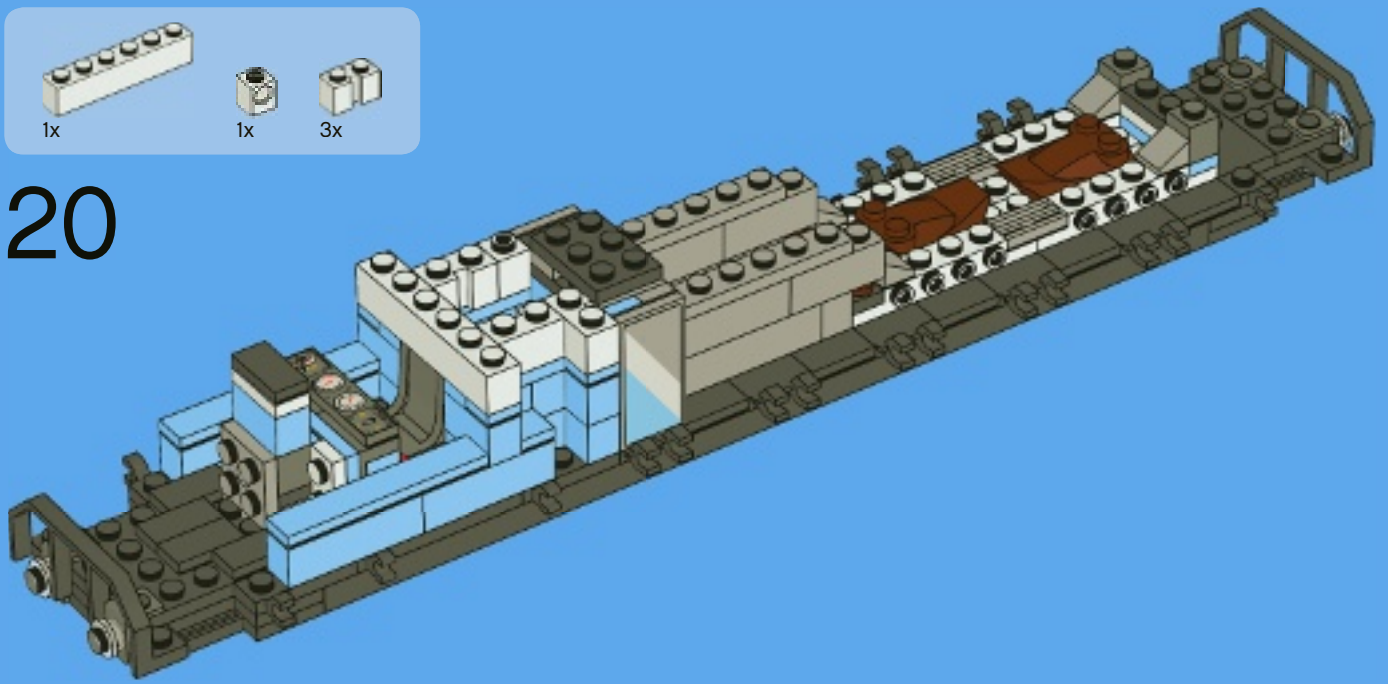

1x



1x



1x



1x



1x

# 21

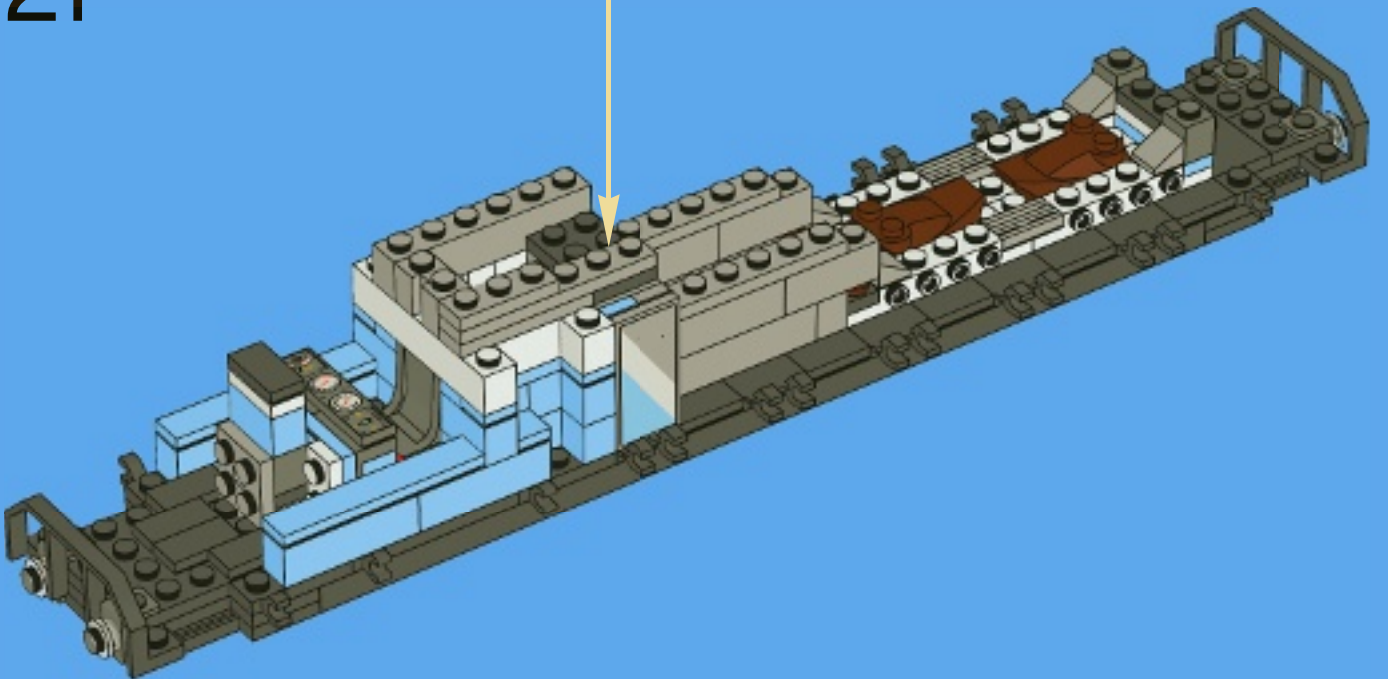
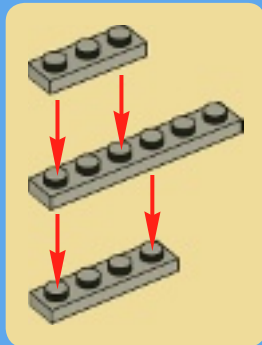



2x



3x



2x

# 22

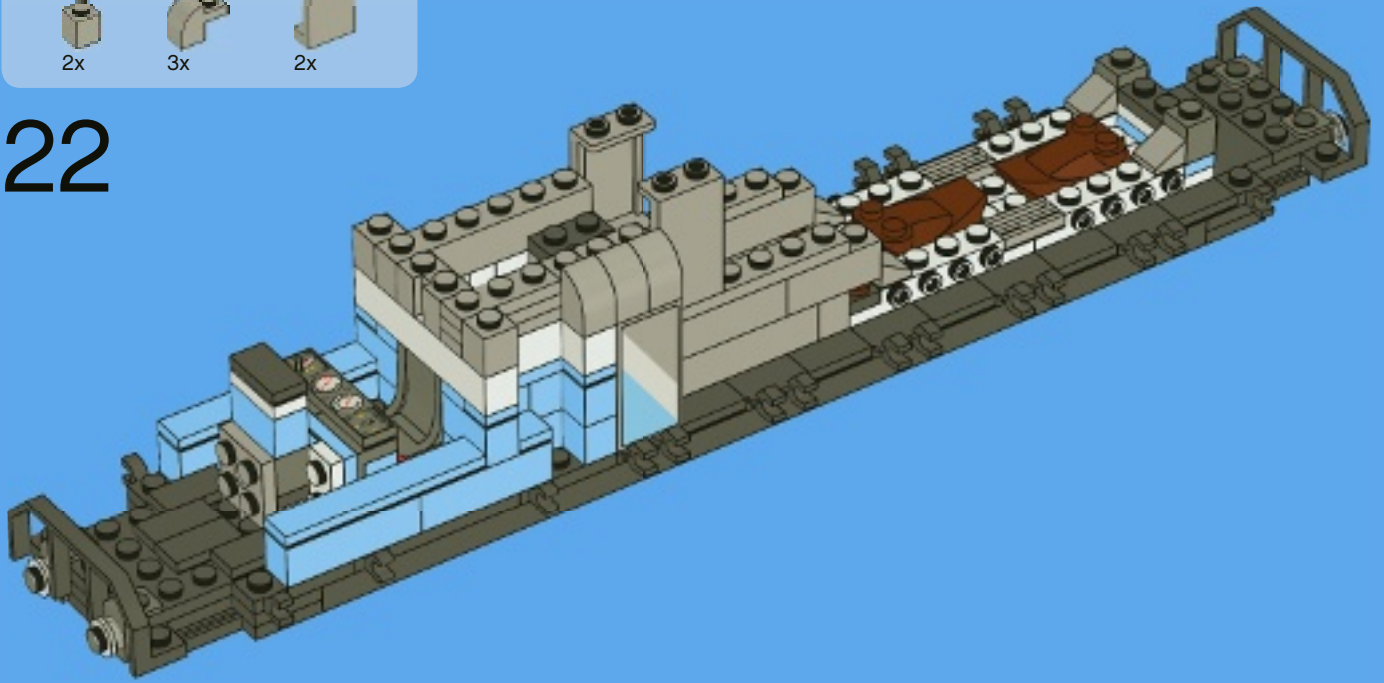

1x



1x



1x



1x

# 23

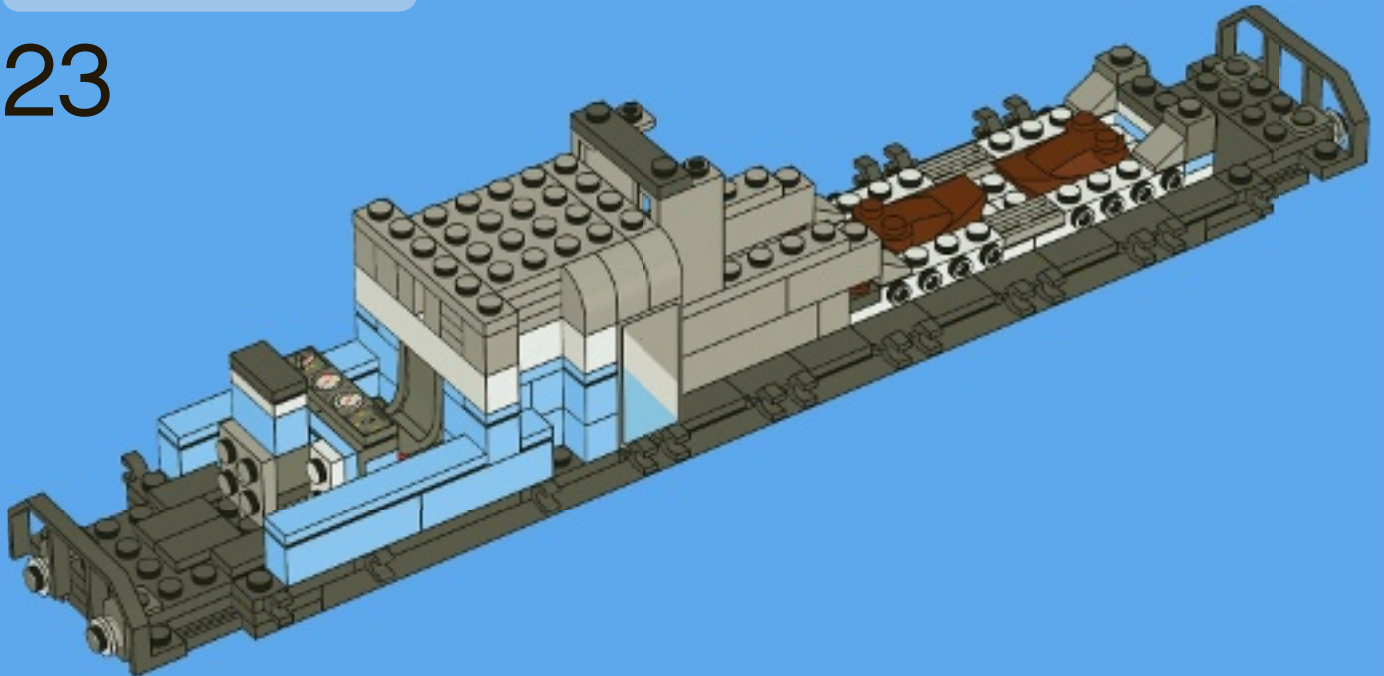



1x



1x

# 24

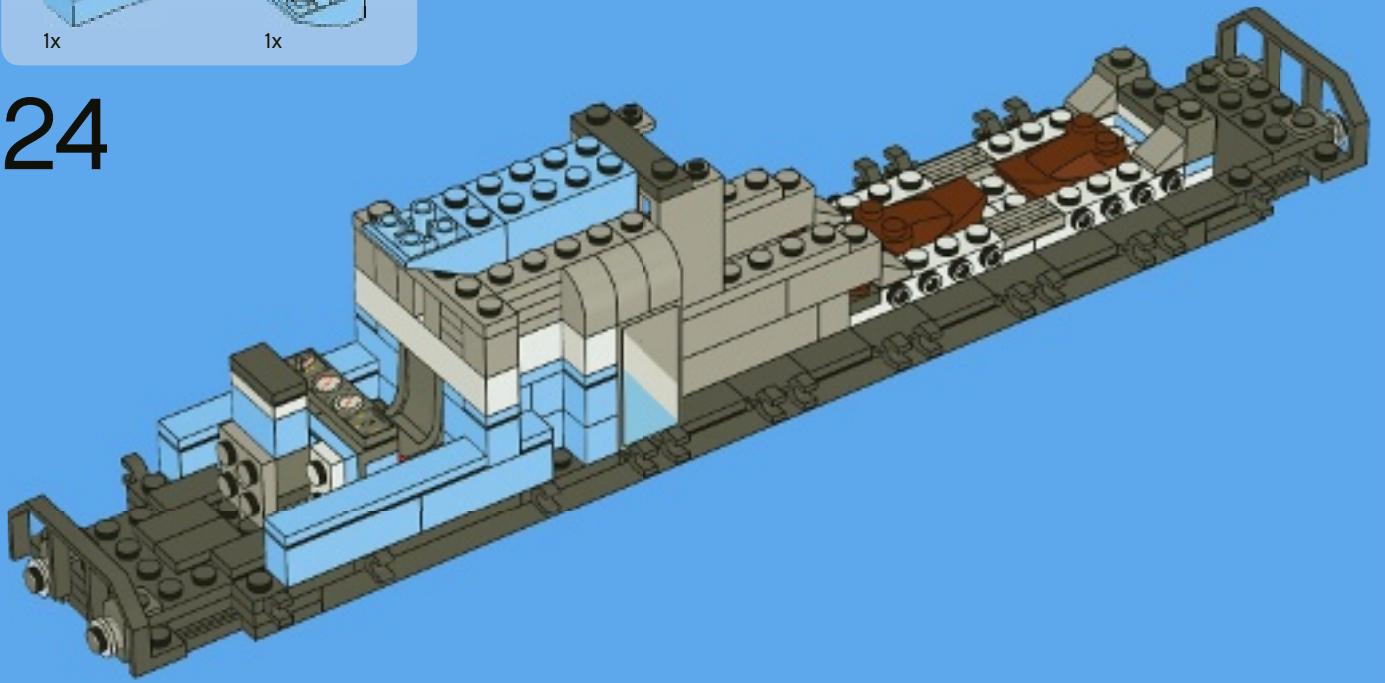

4x



2x



2x

# 25

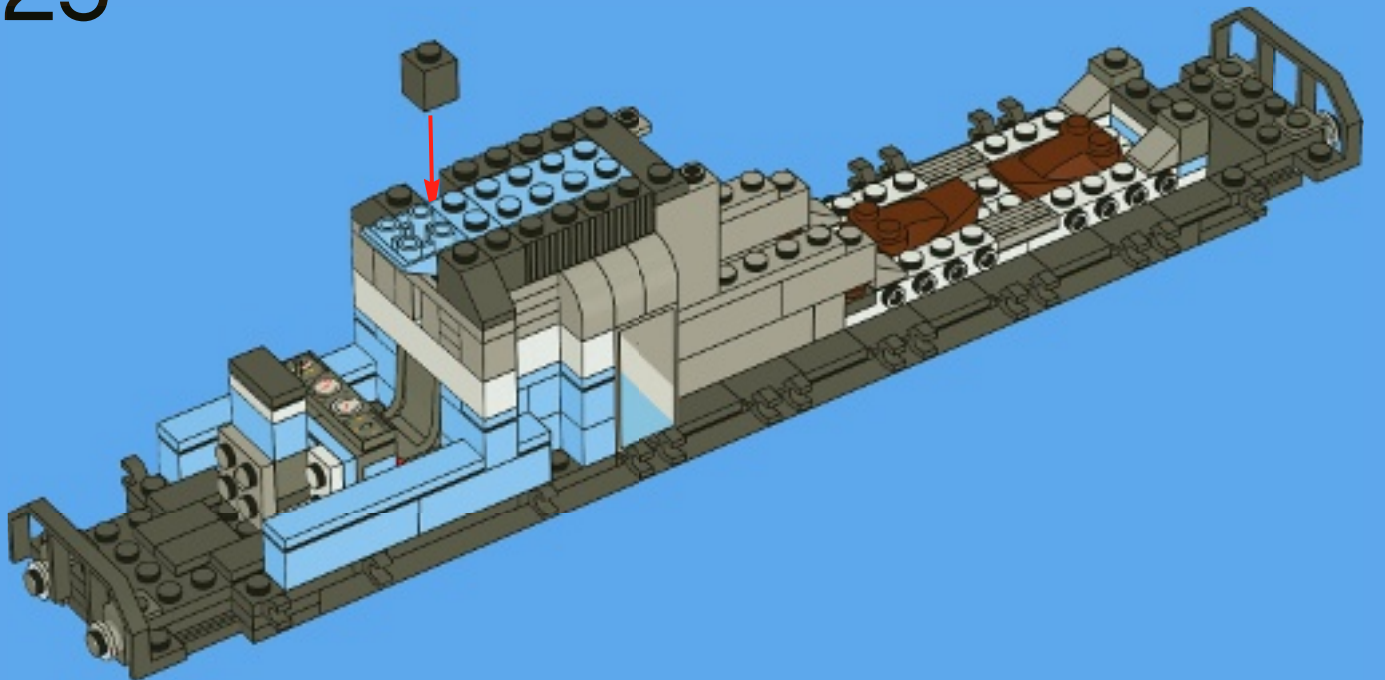

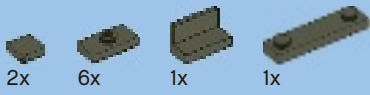

26

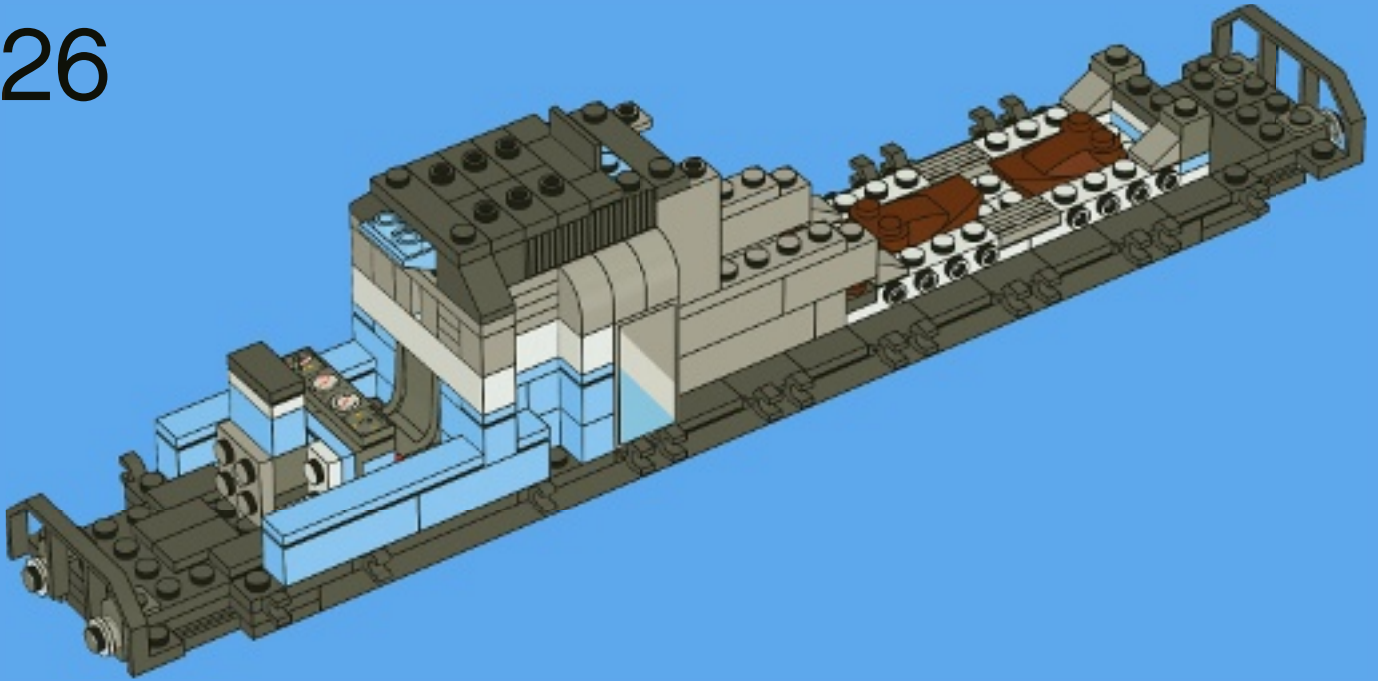

27

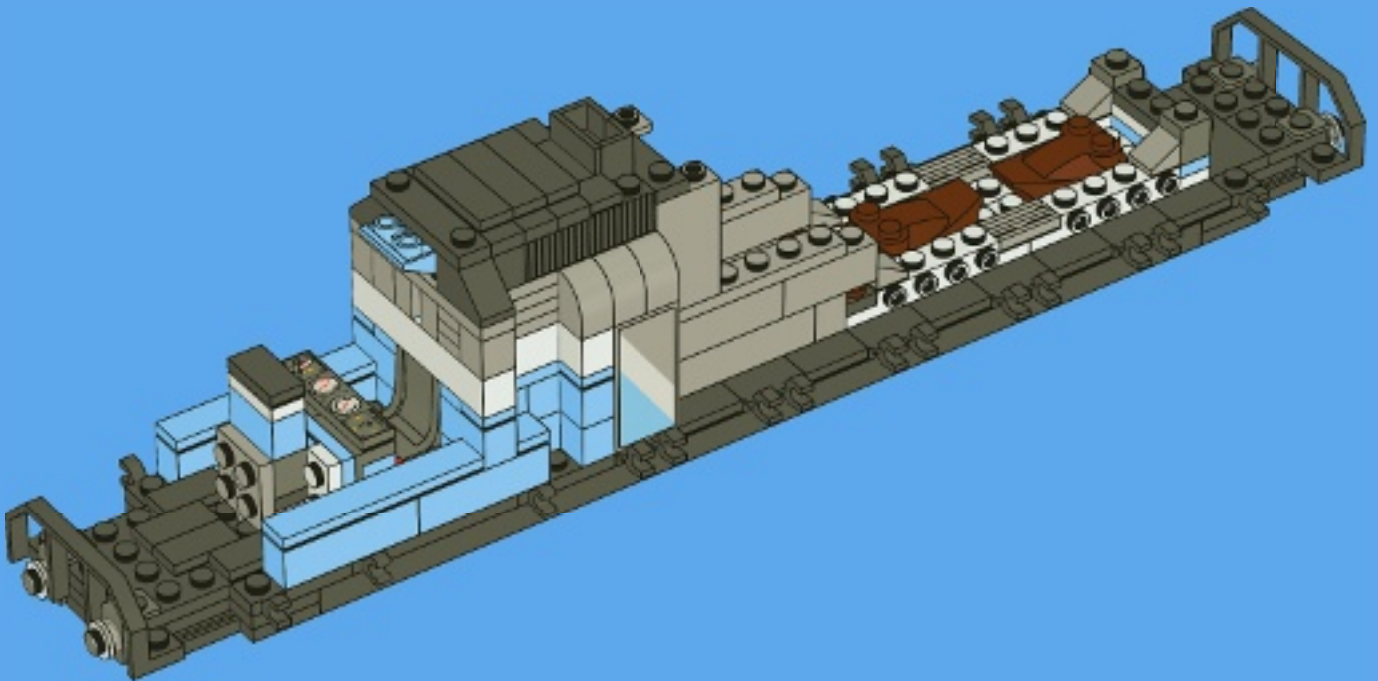





# 28

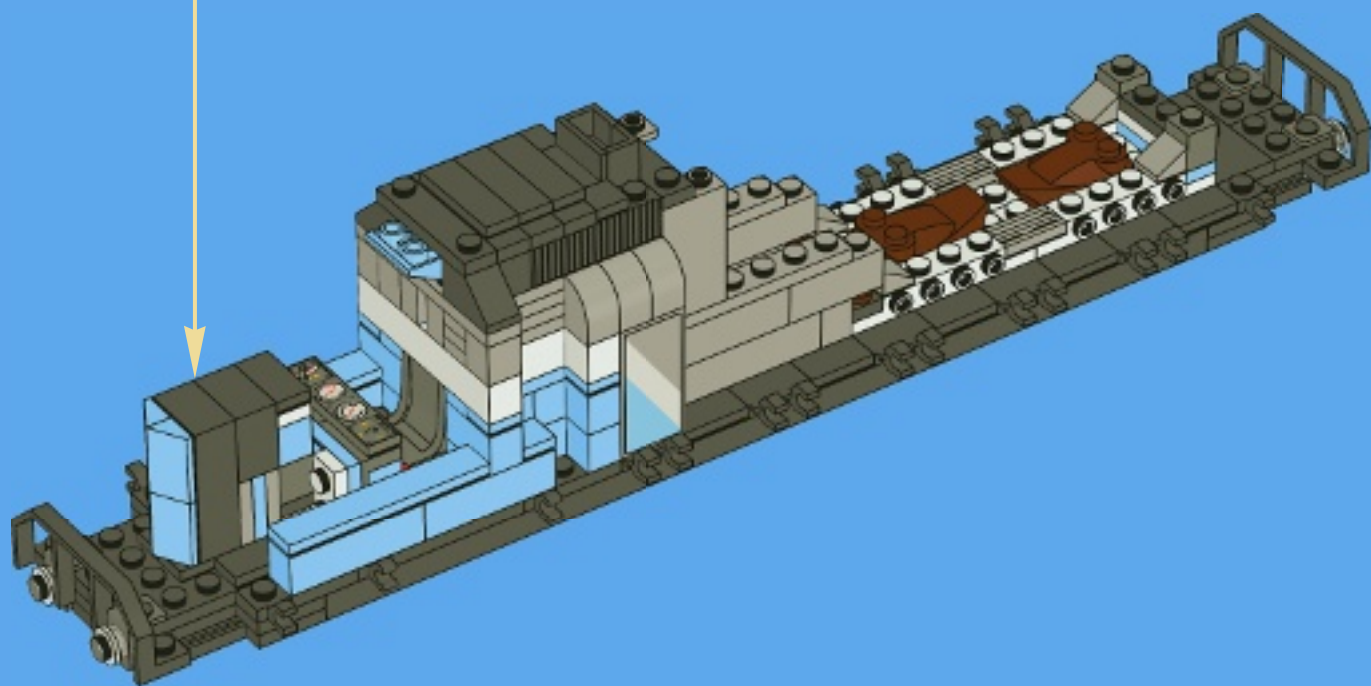
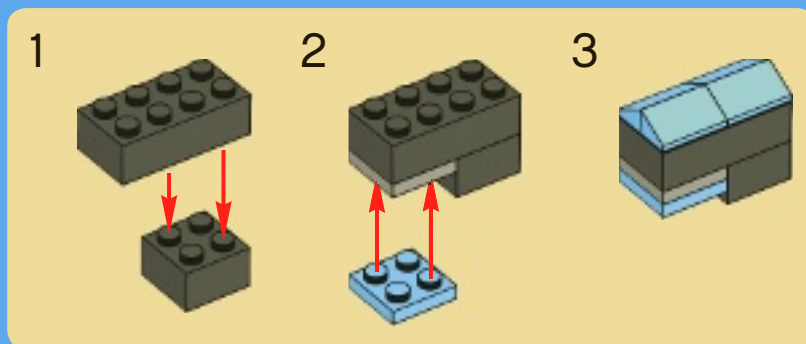

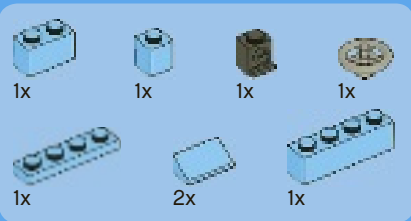

29

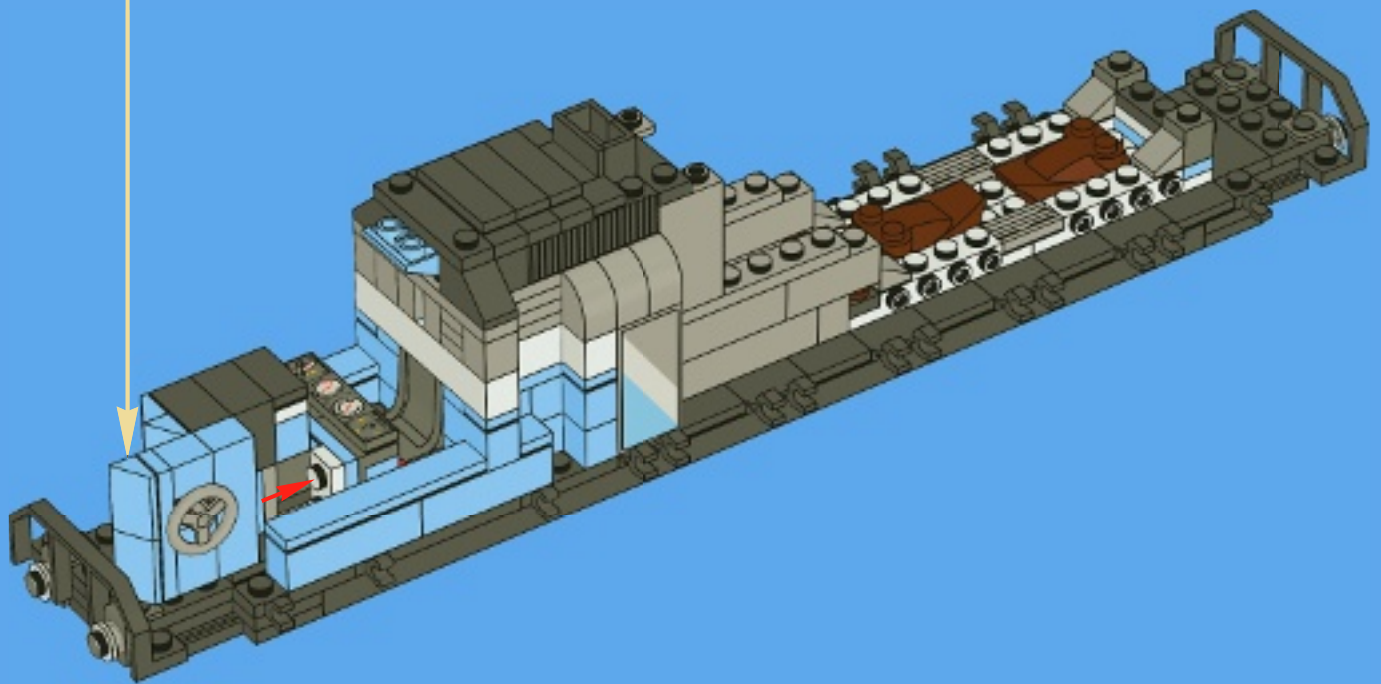
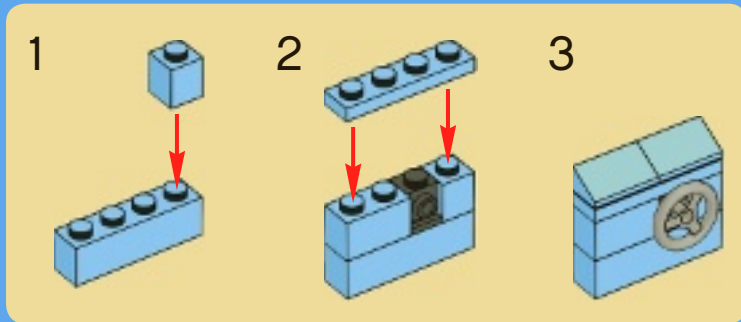

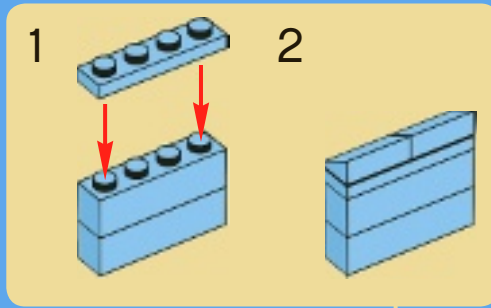
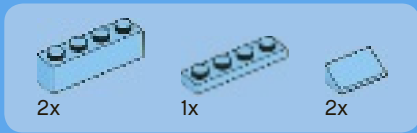

30

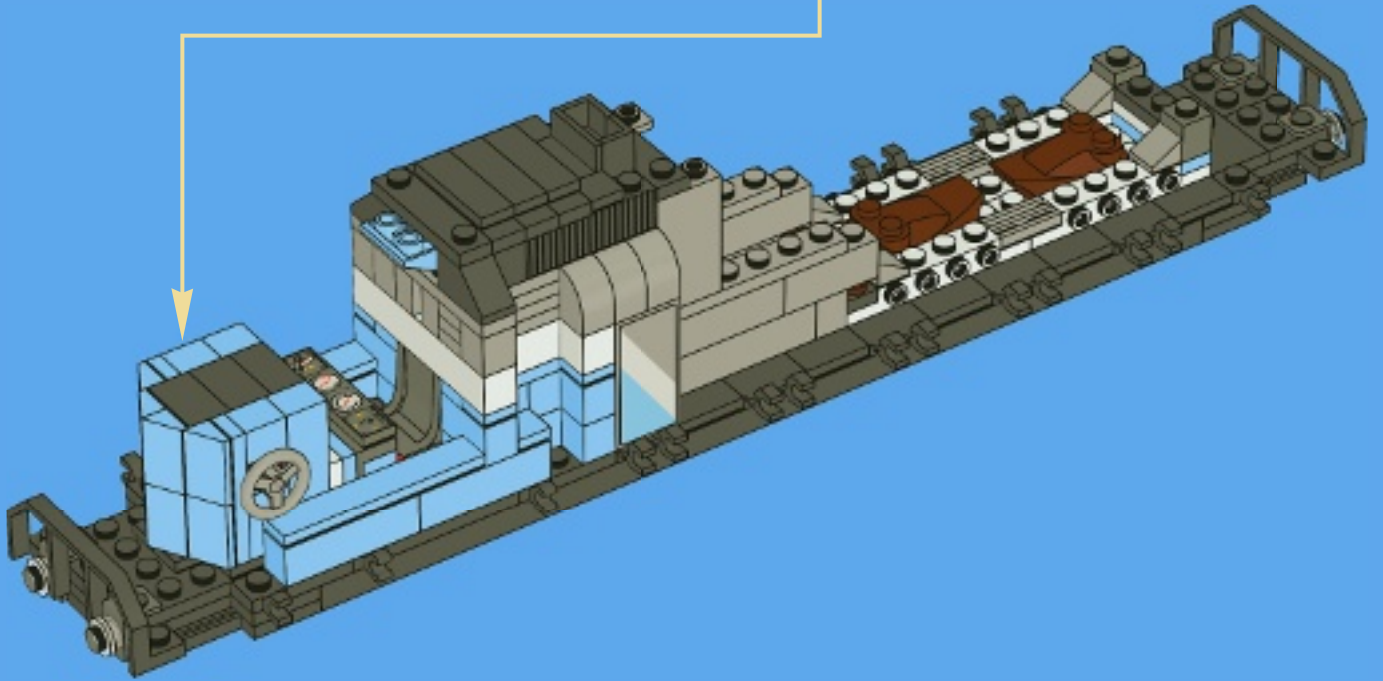

31

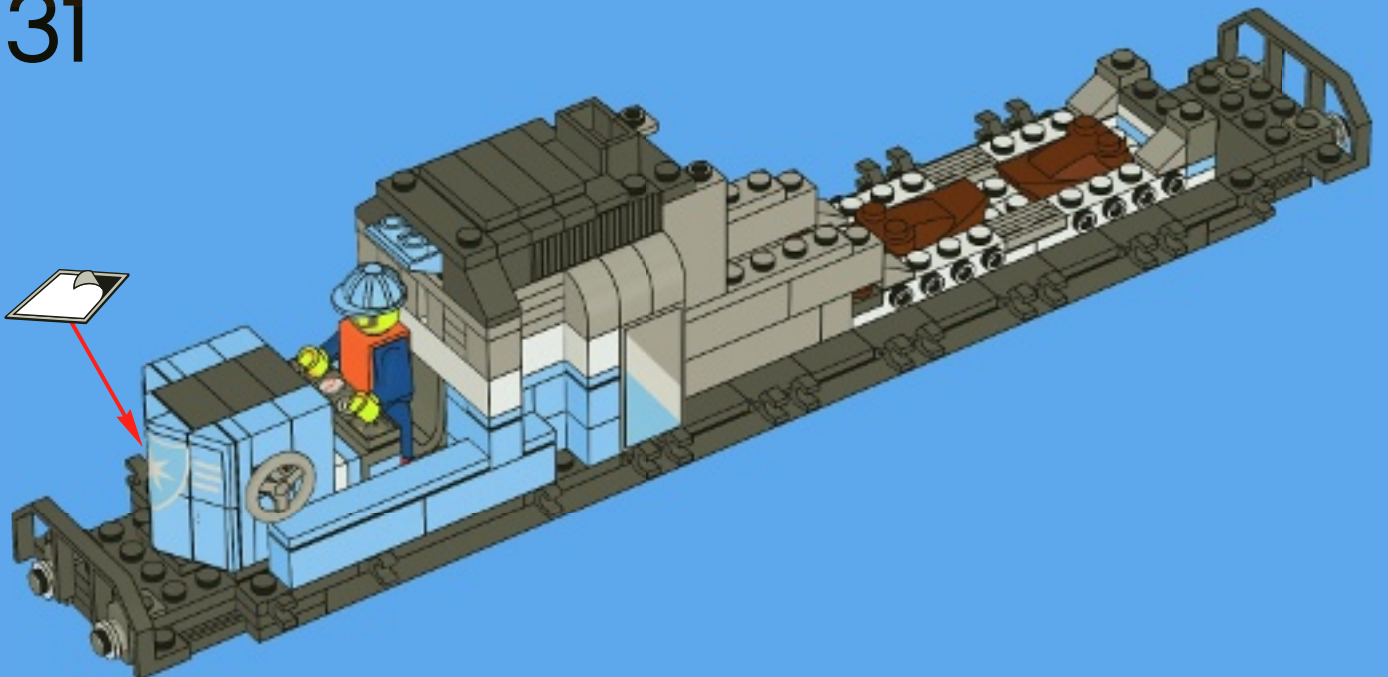

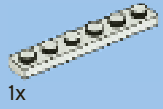

1x



1x

1

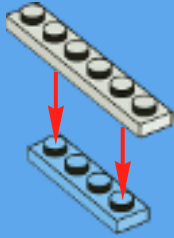

2x

2

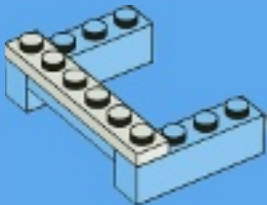

2x

3

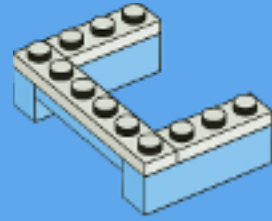

6x

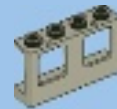

3x

4

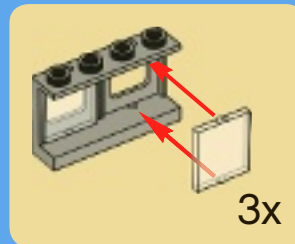

3x

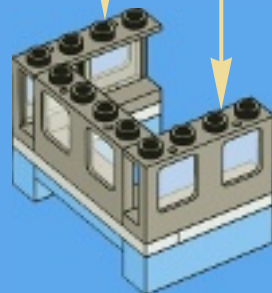



5

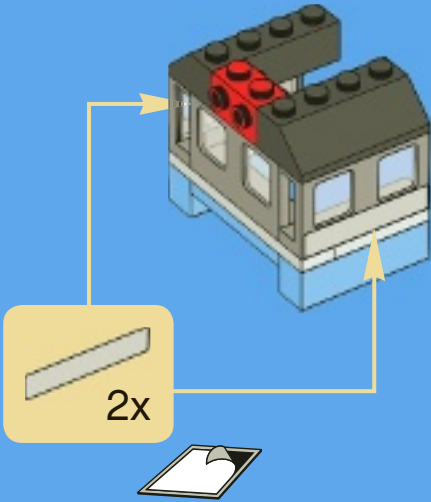

2x

1x



6

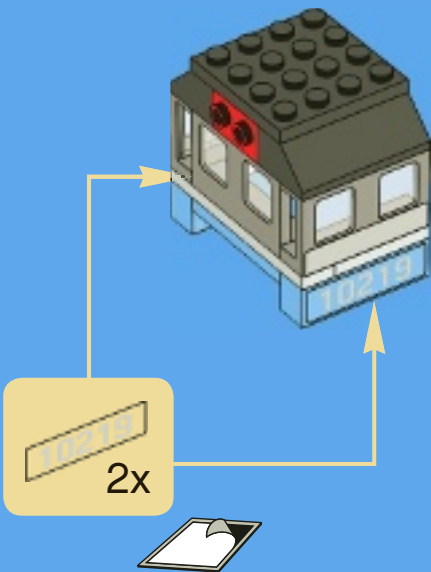

2x

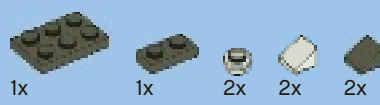

7



1

2

3



8

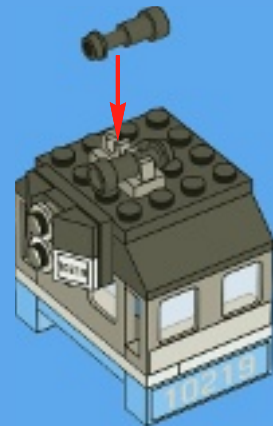

32

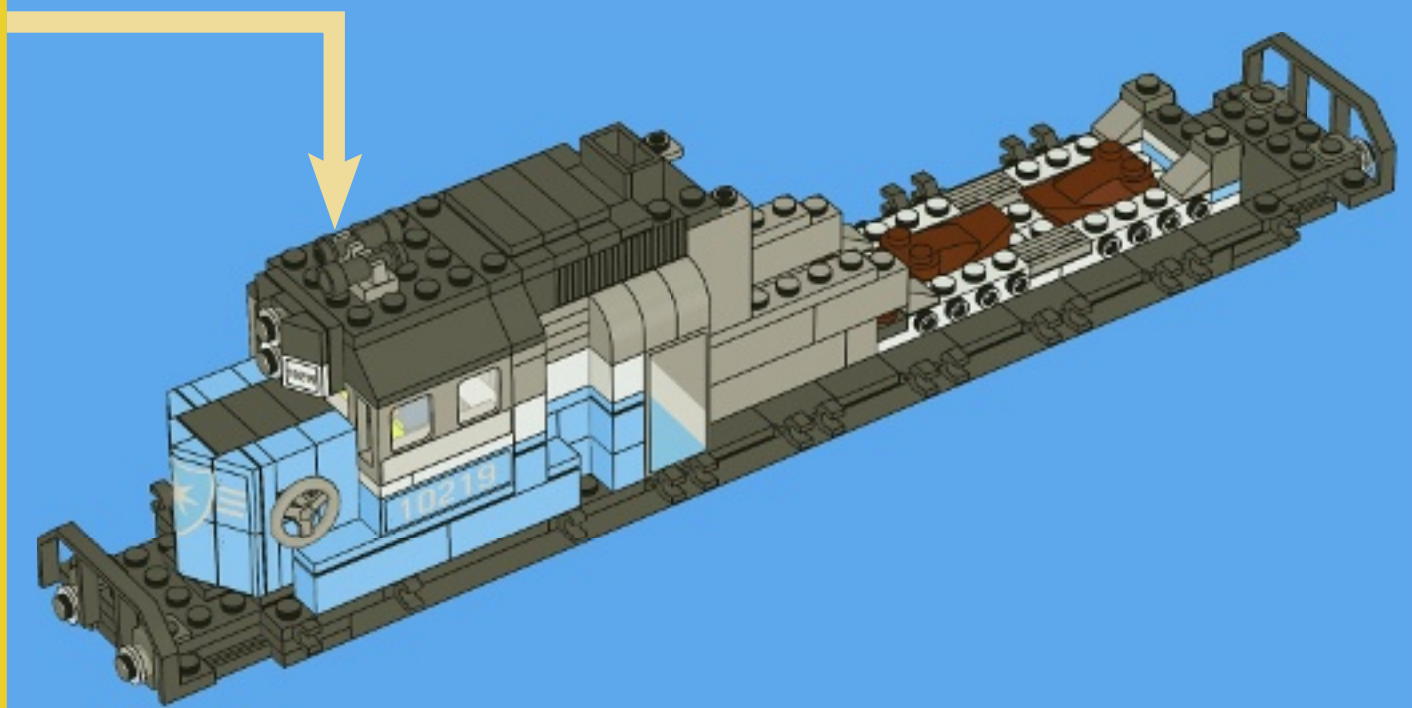

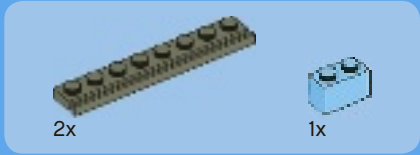
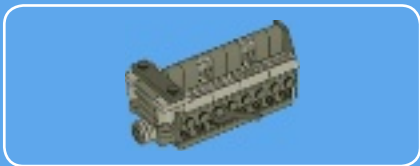

1

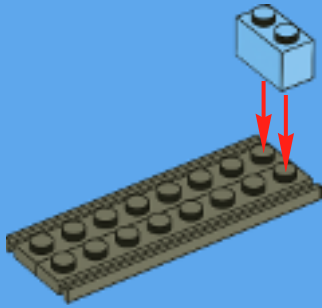

2

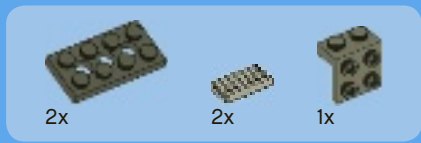
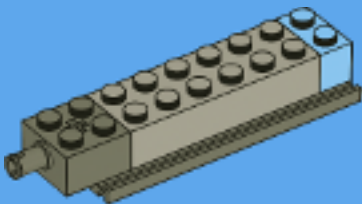

3

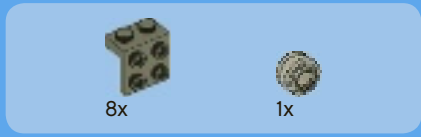
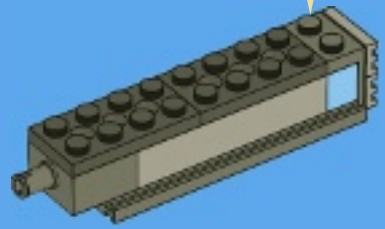
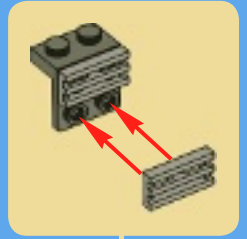

4

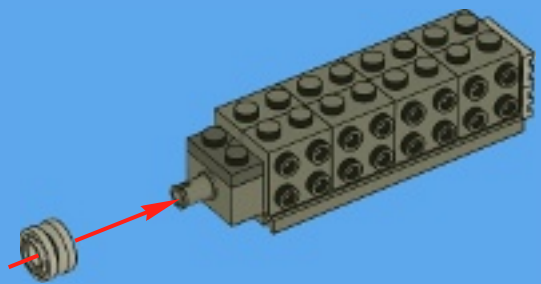



5

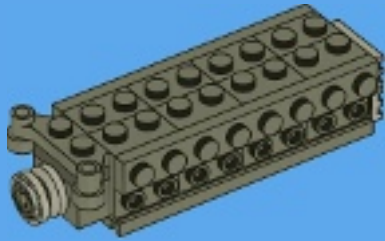

7

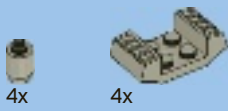
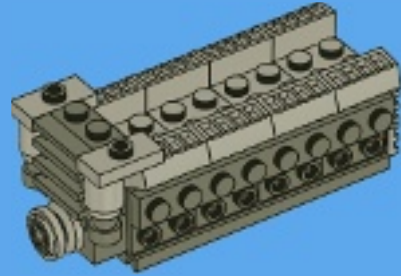

6

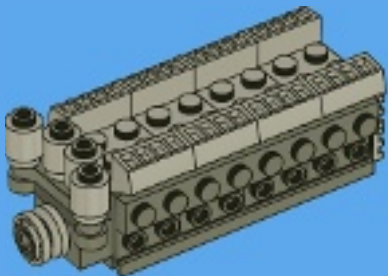

8

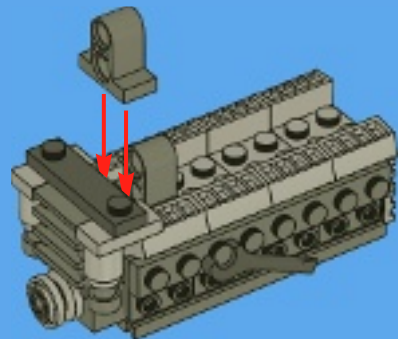





2x



4x



1x

# 9

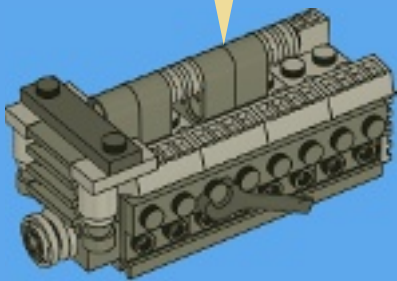
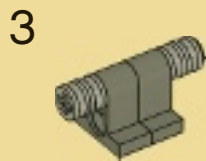
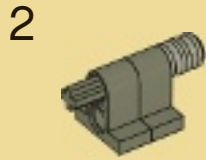
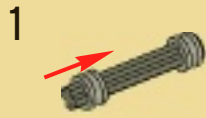

1x

# 10

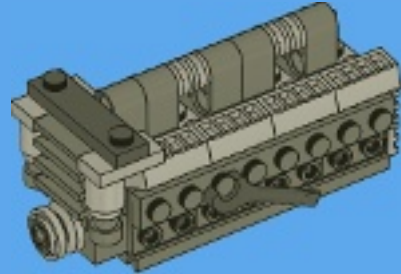

1x



2x



1x

# 11

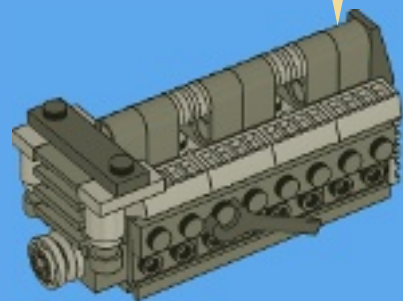
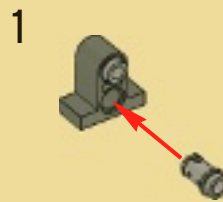

33

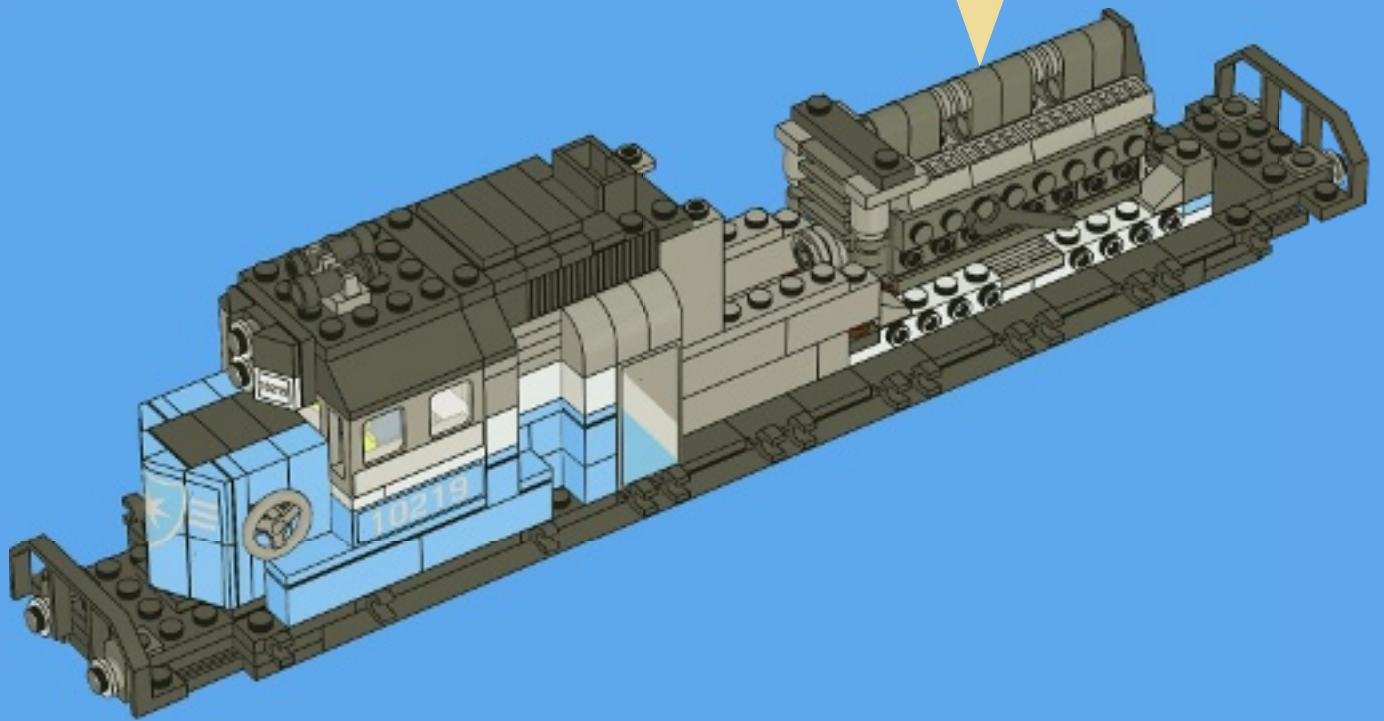

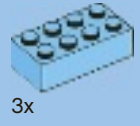
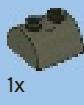

2x

1x

3x

# 34

1

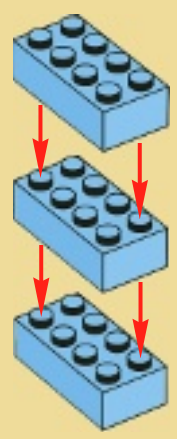

2

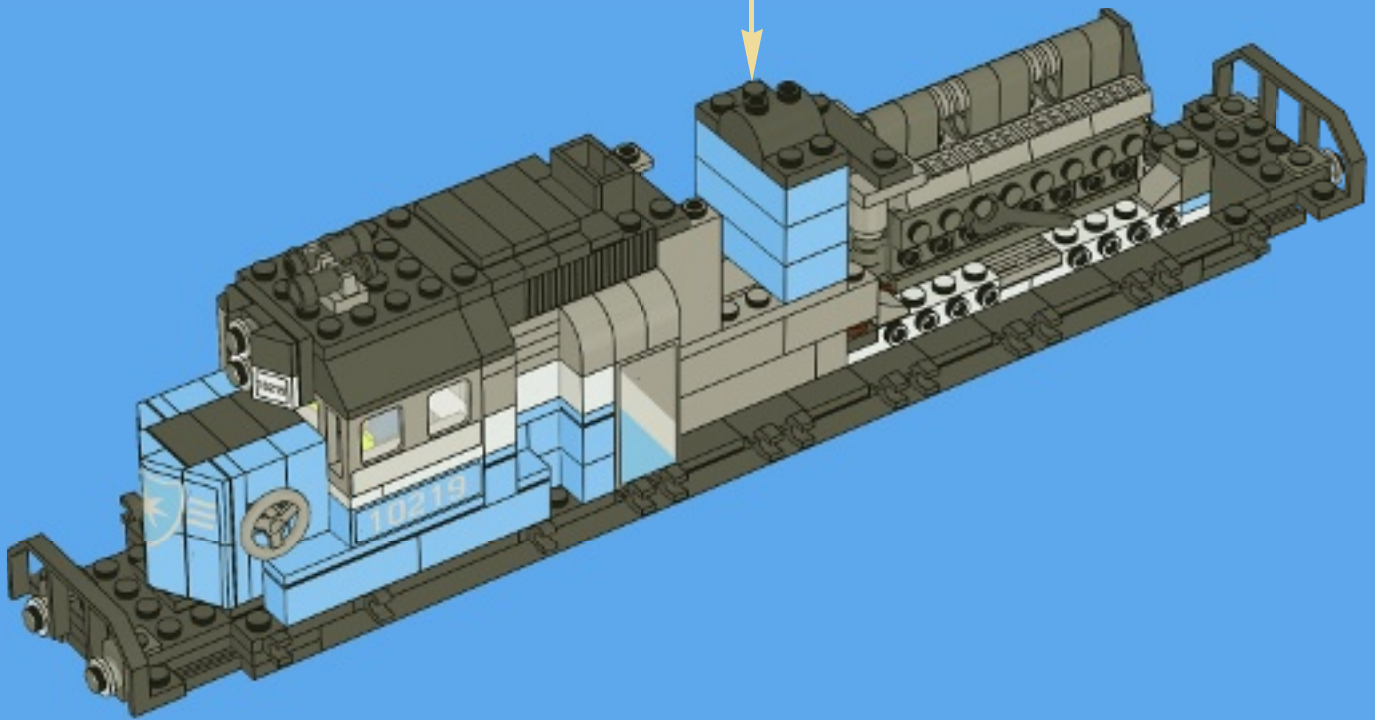
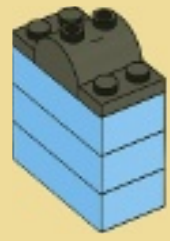



2x



3x

# 35

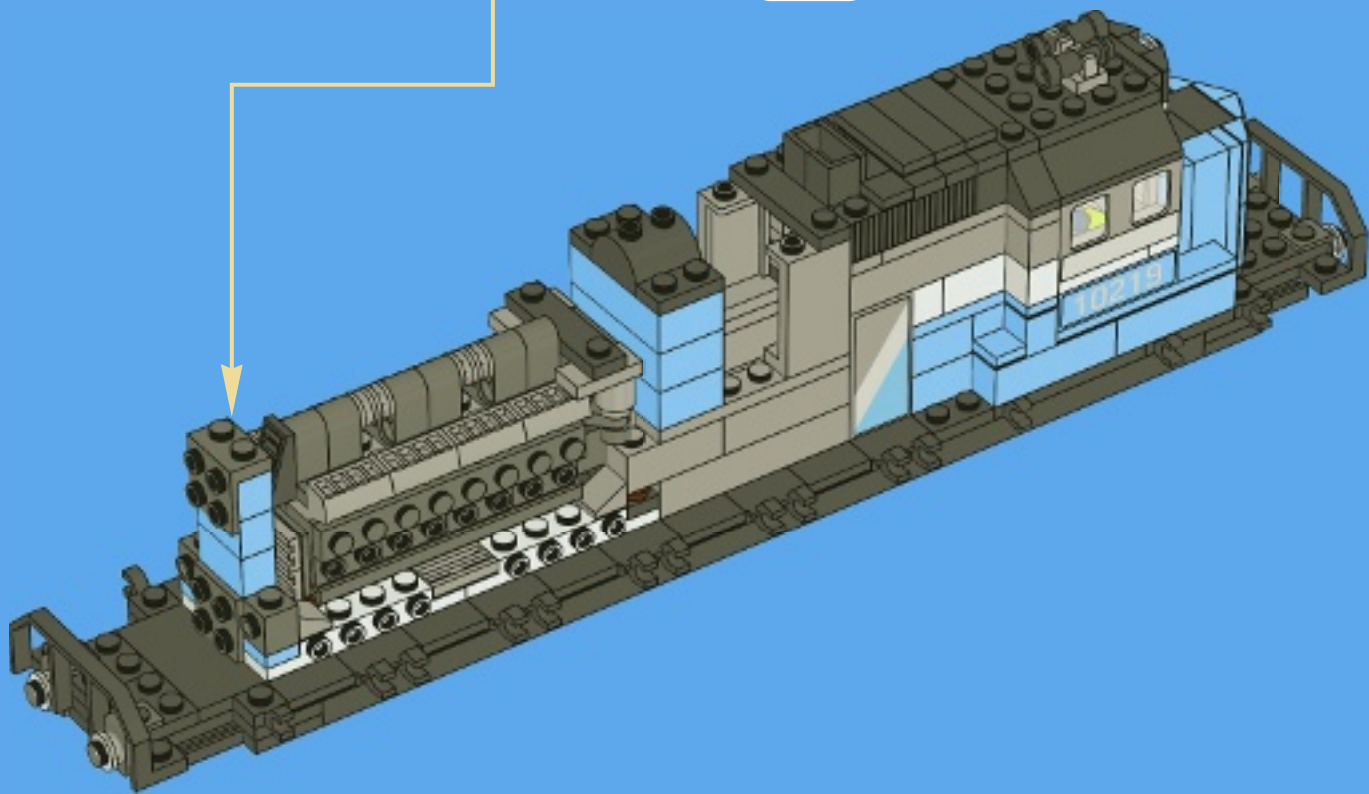
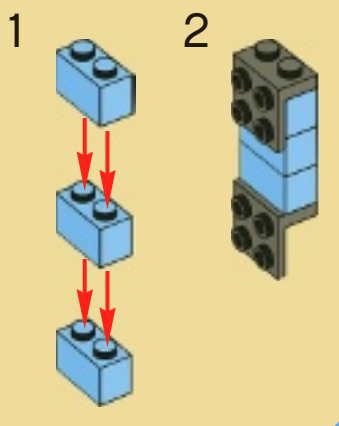



4x



4x

# 36

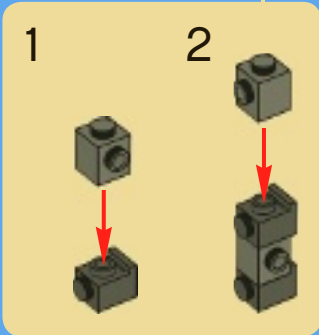
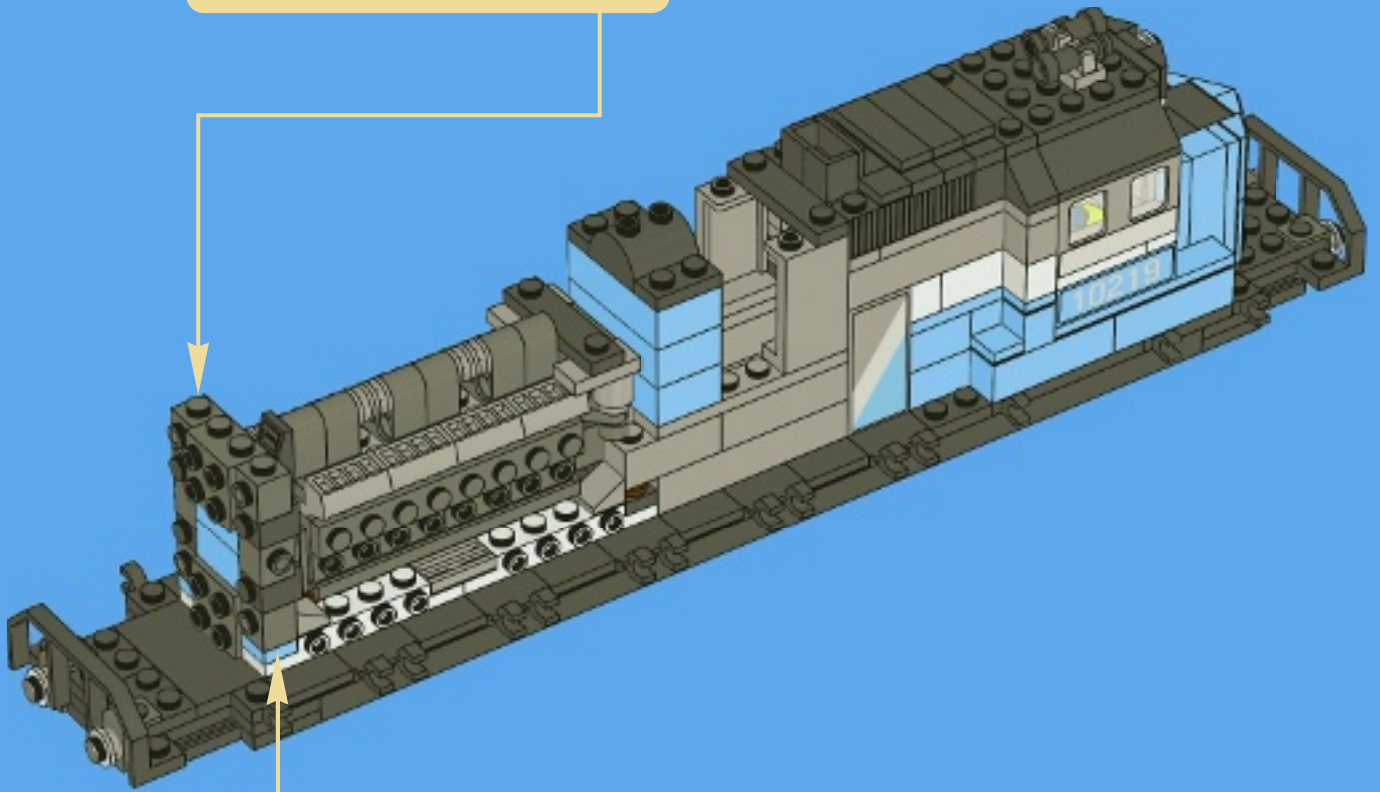
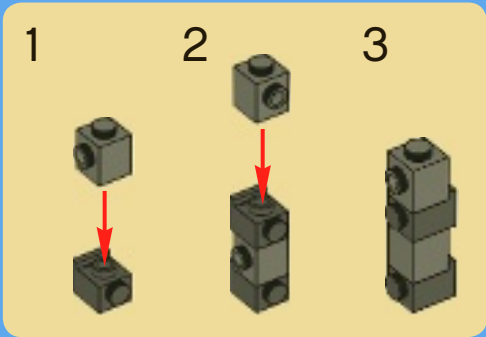



2x



1x

# 37

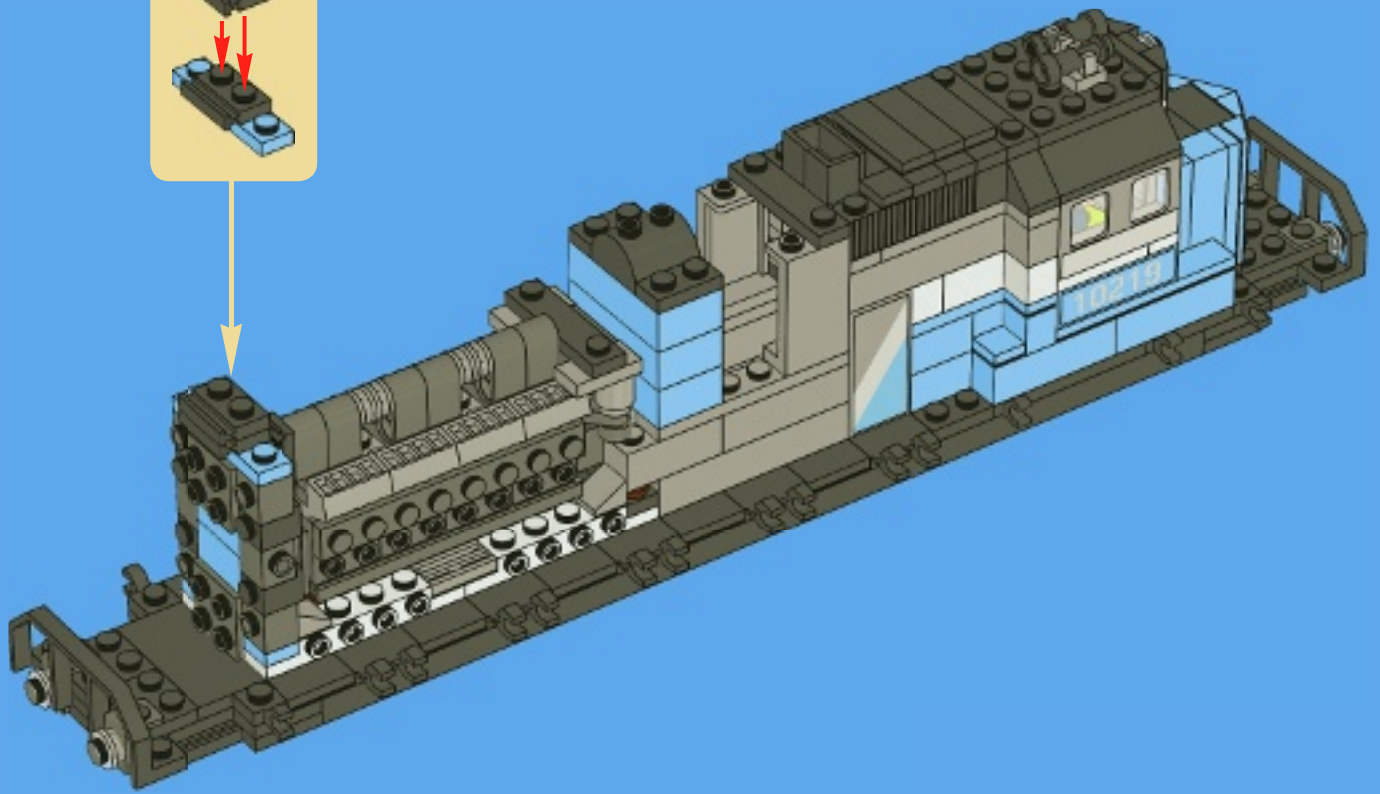
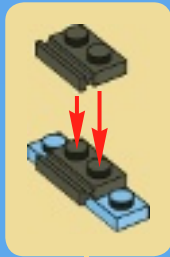

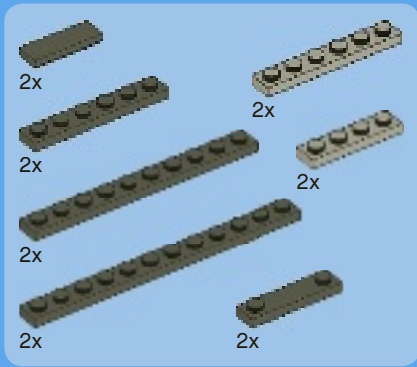

38

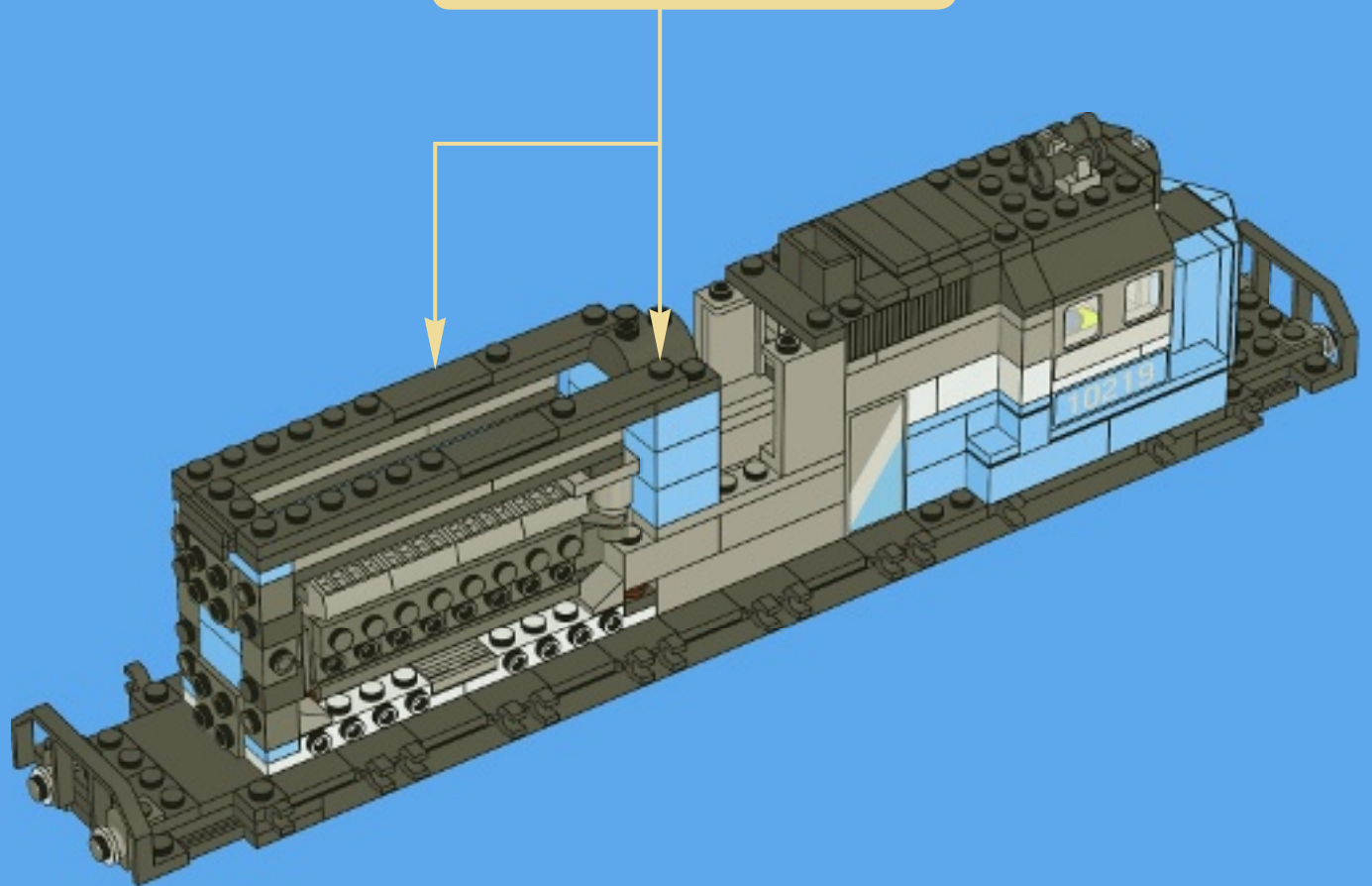
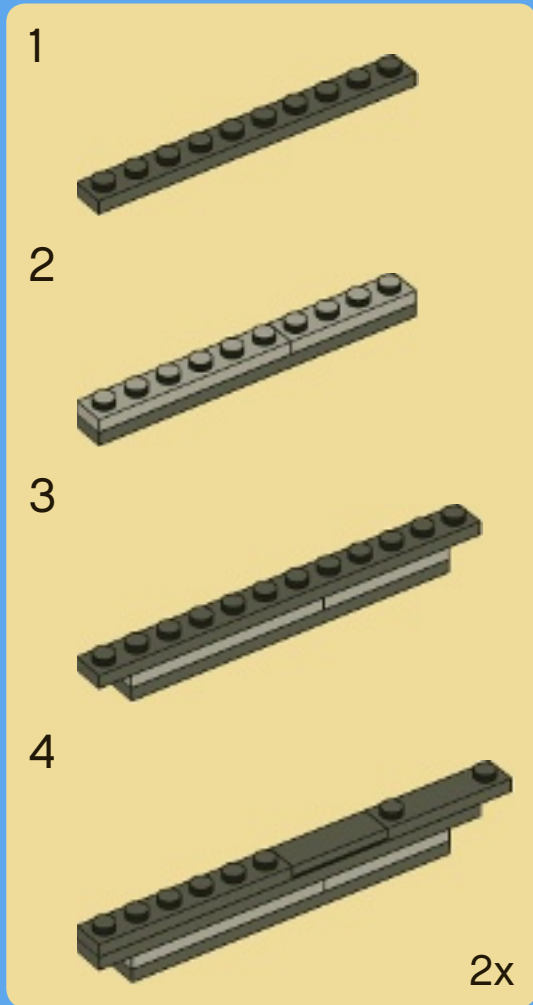

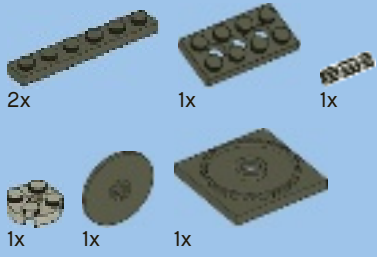

39

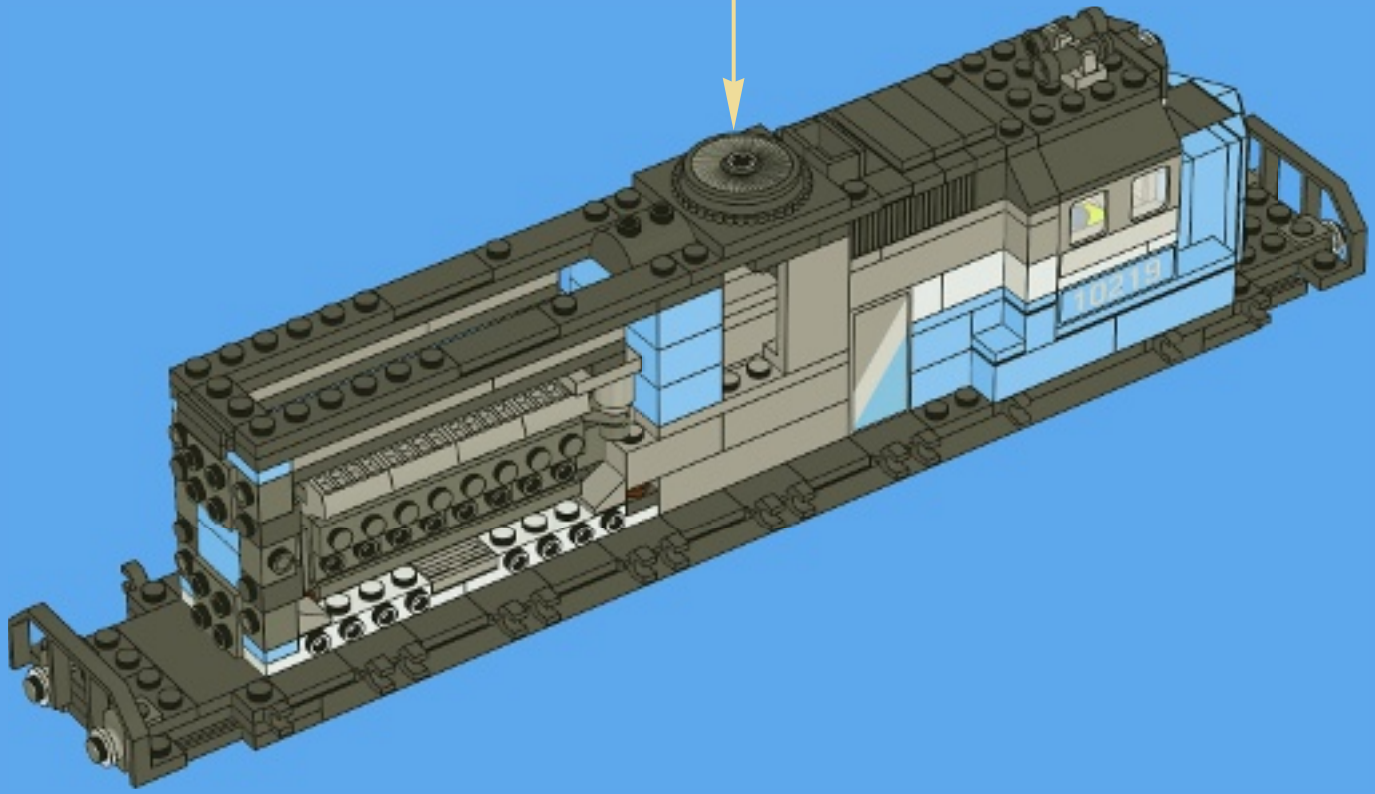
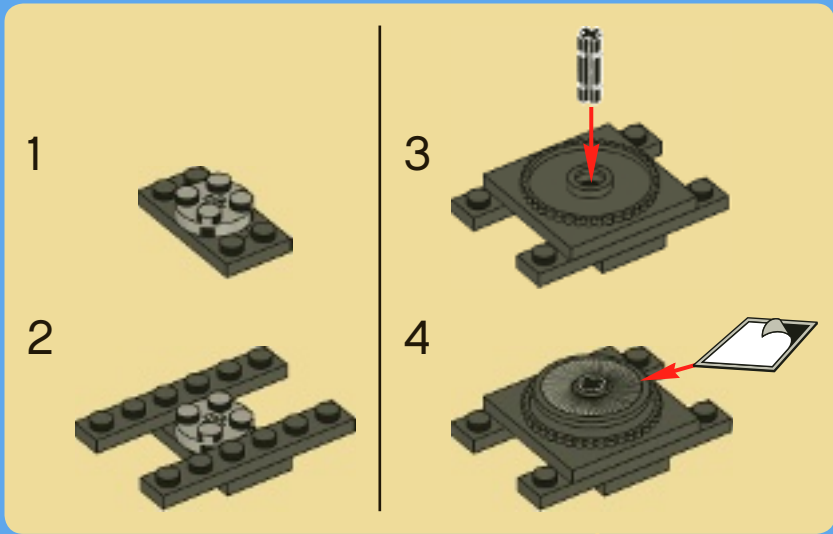





40

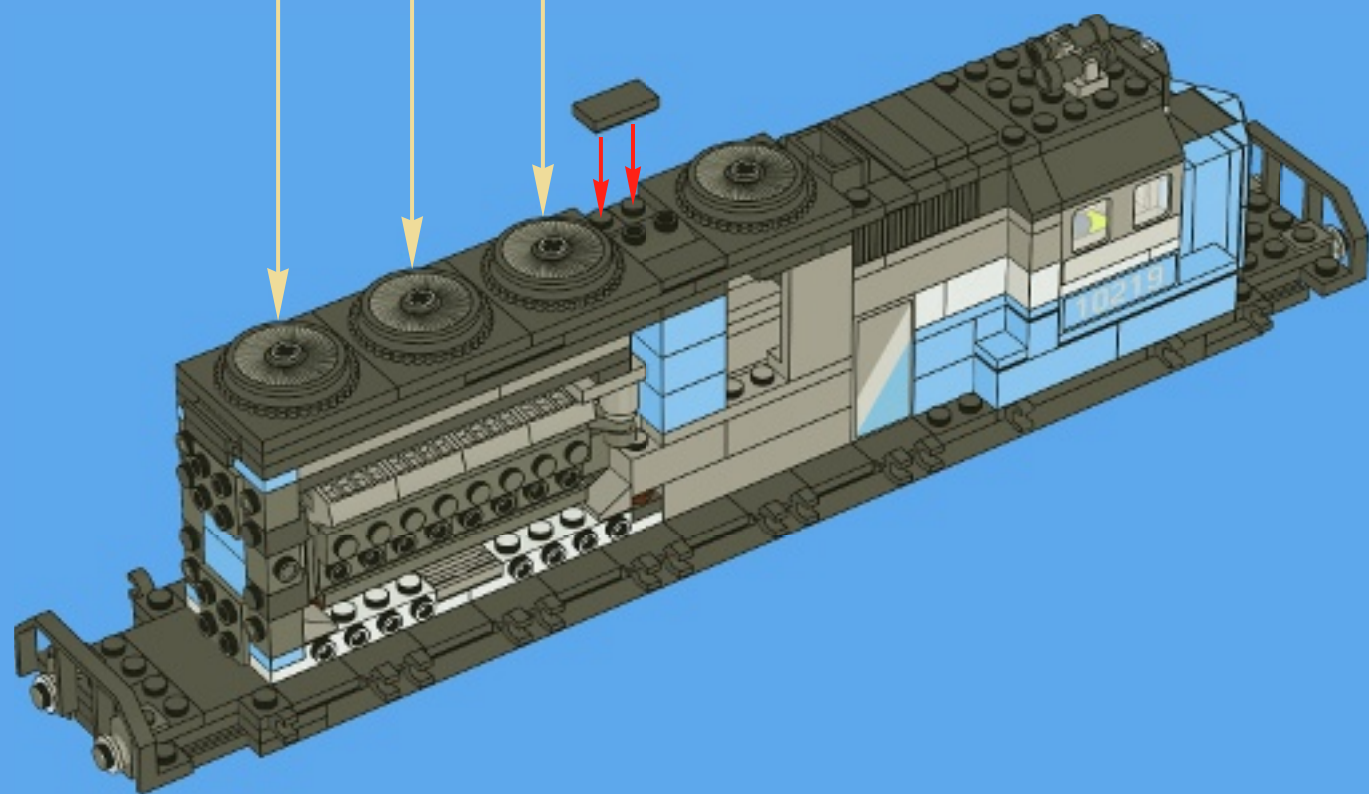
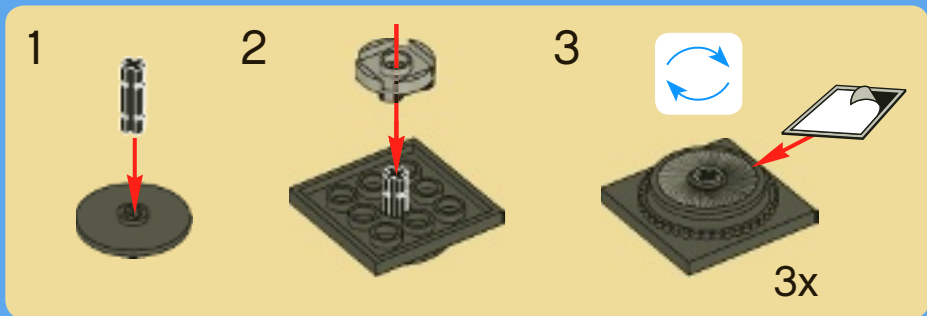

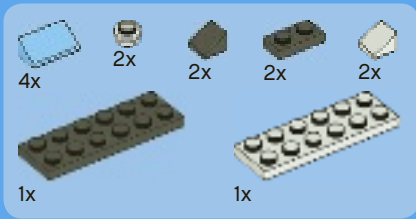

41

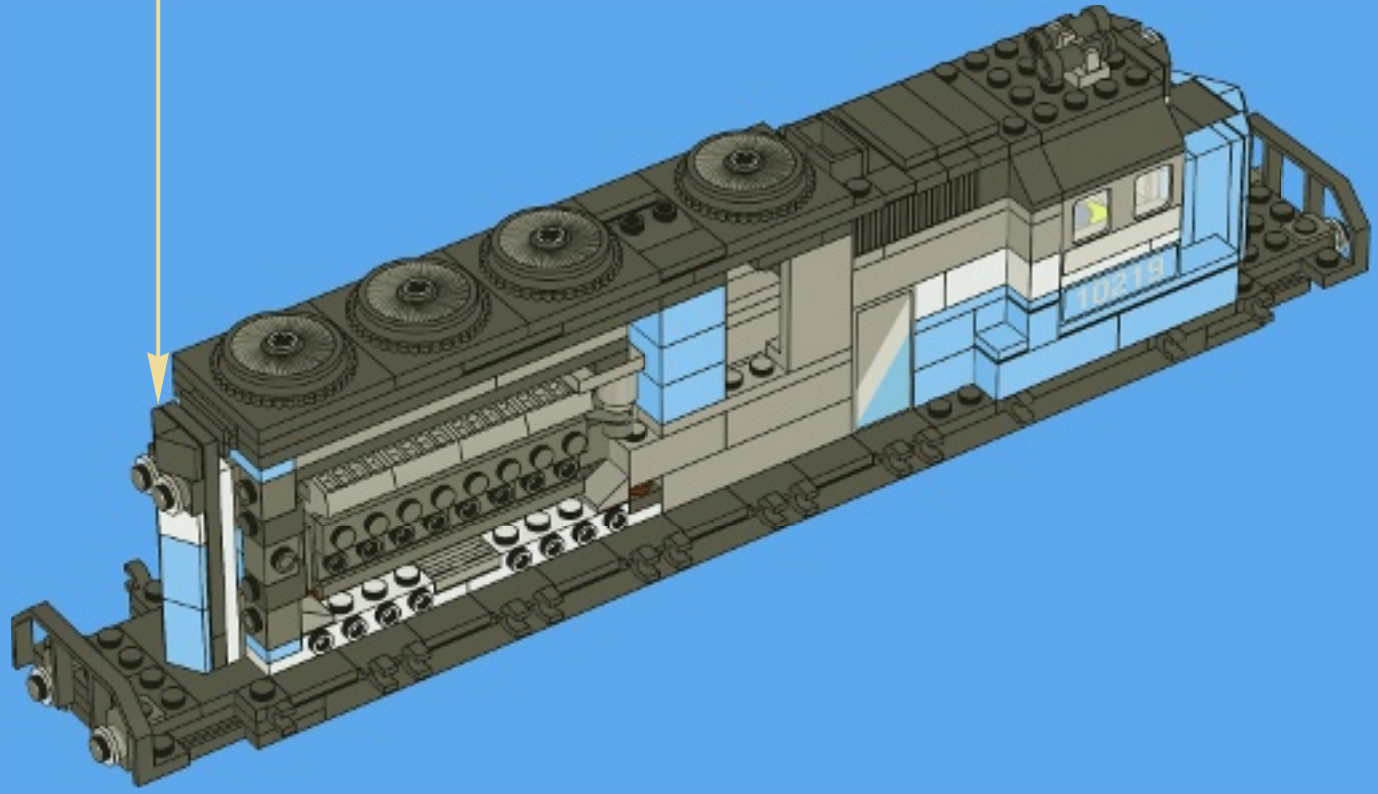
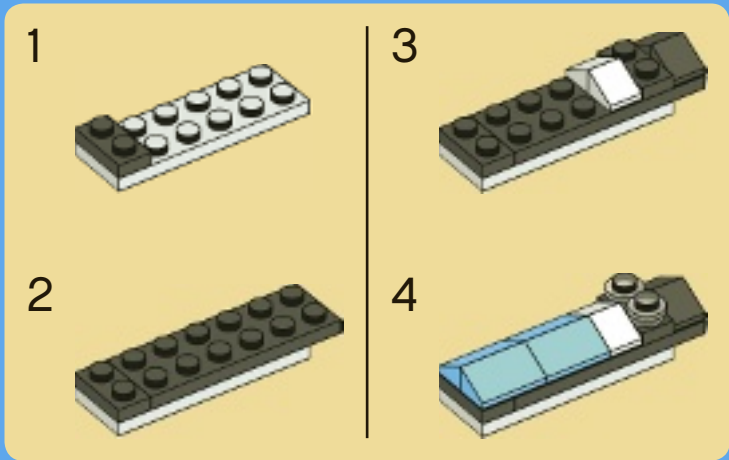



2x



4x

# 42

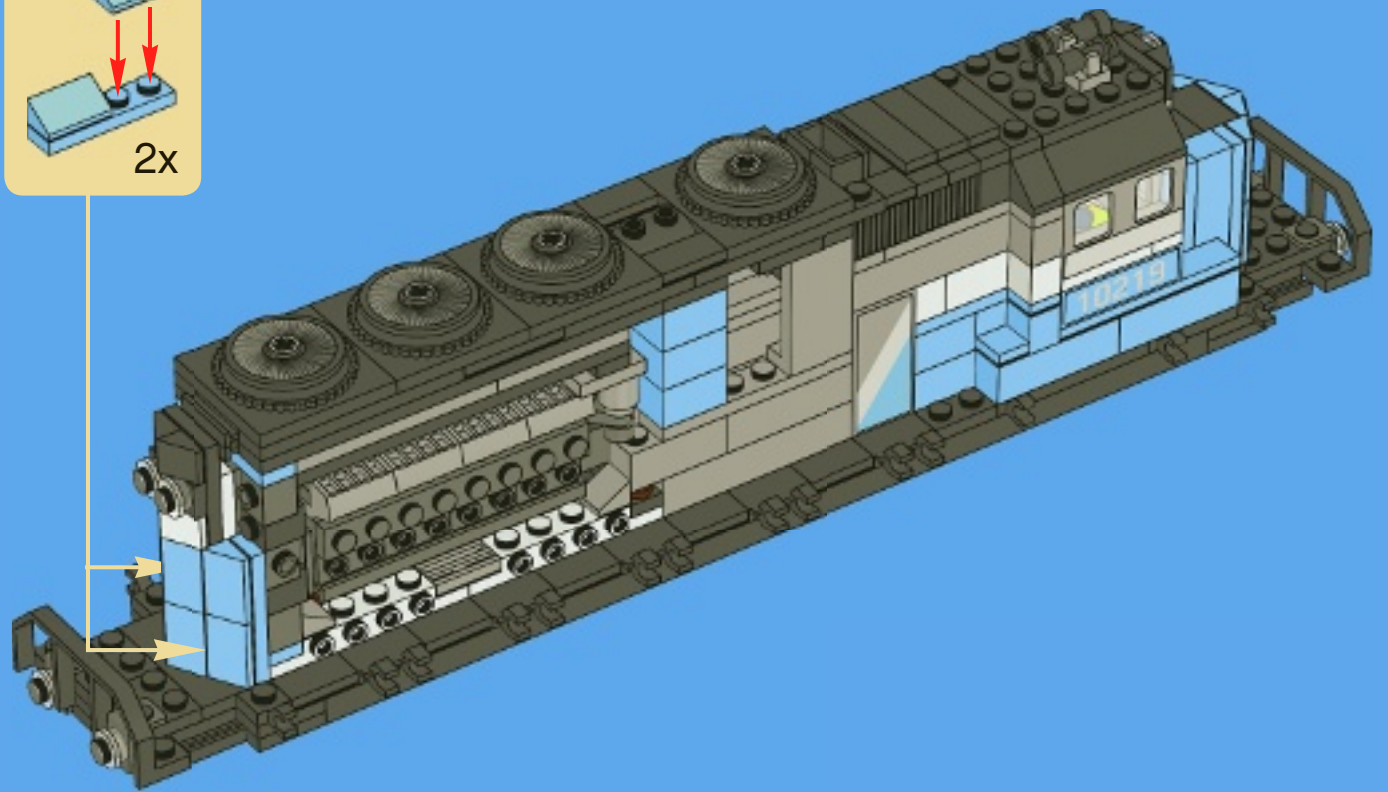
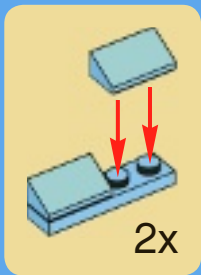



2x



2x



2x

# 43

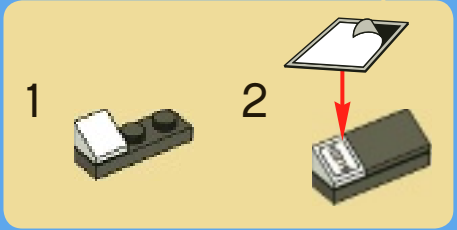
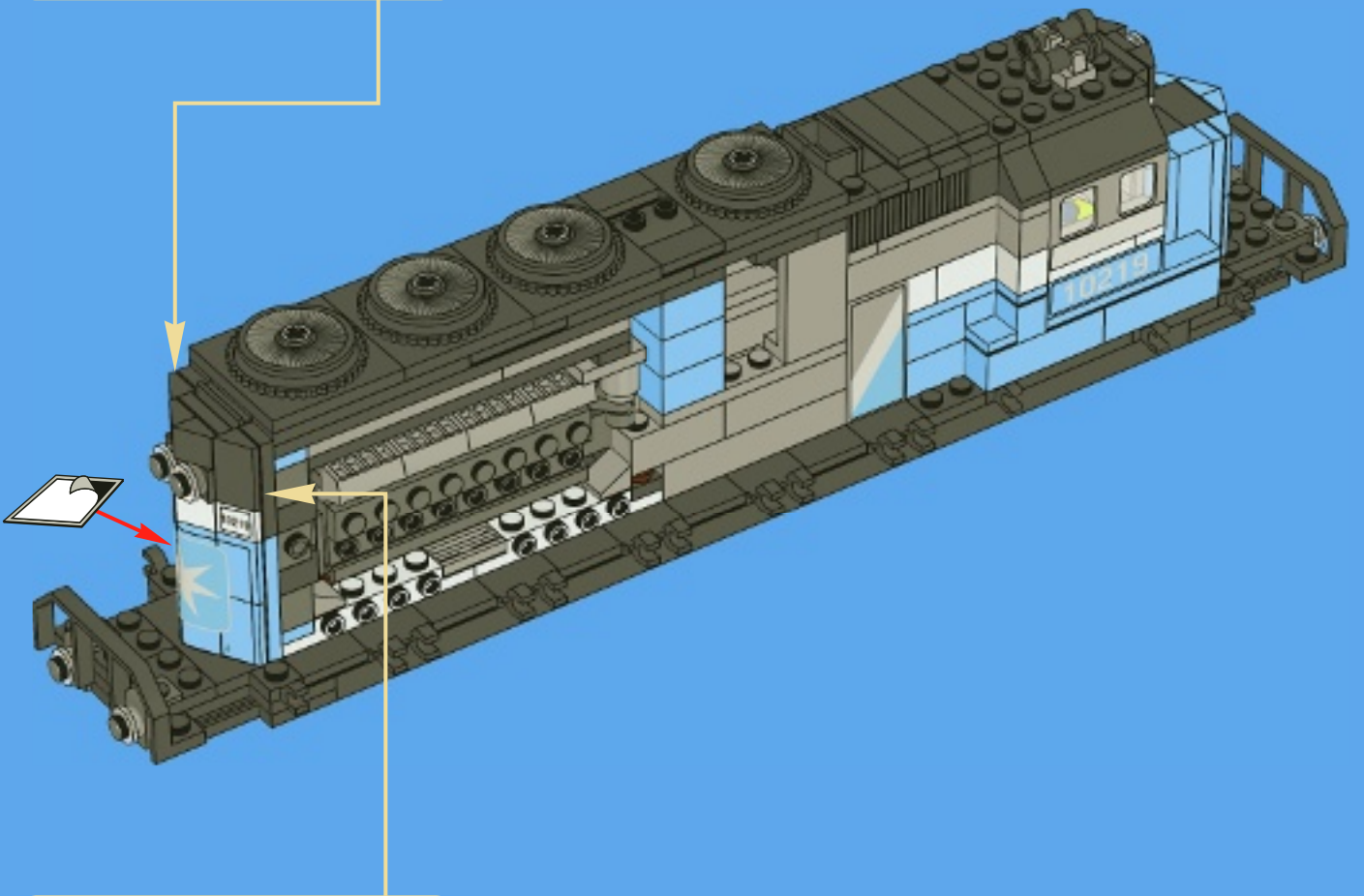
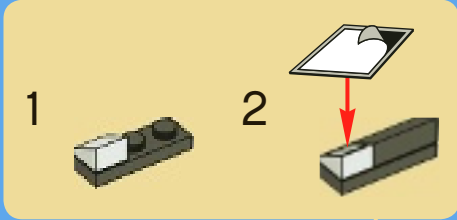

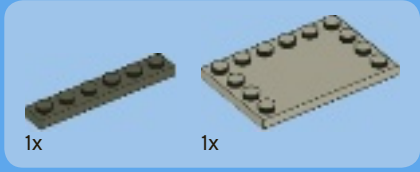
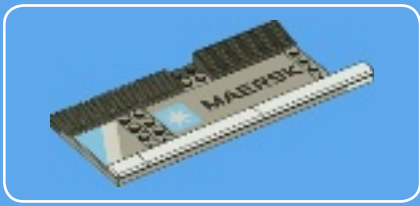

1x

1x

1

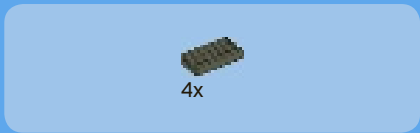

4x

2

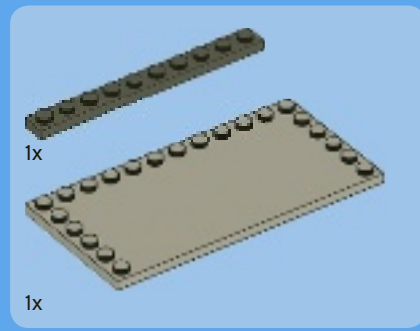

1x

1x

3

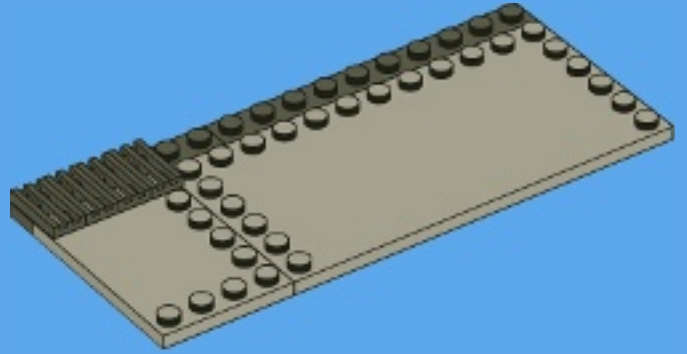

4x

6x

4

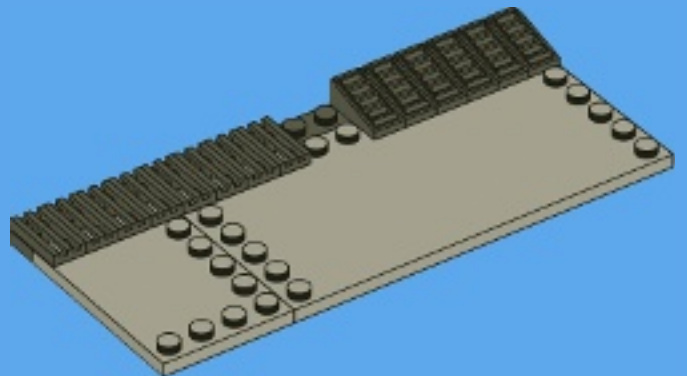

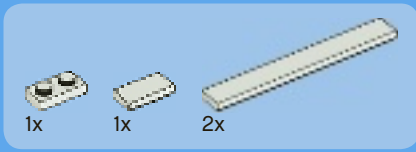

5

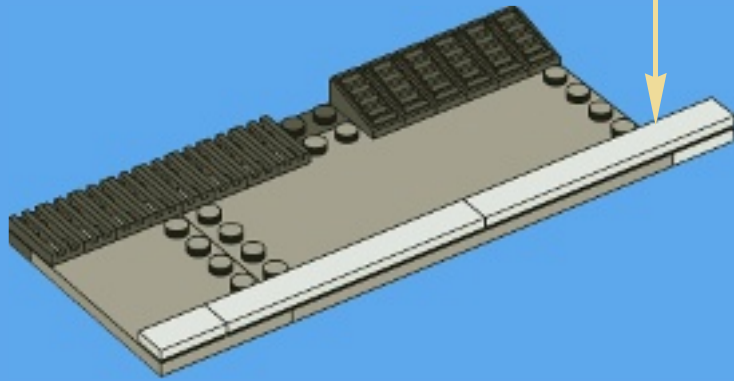
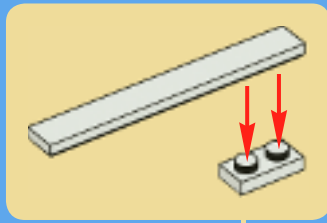

6

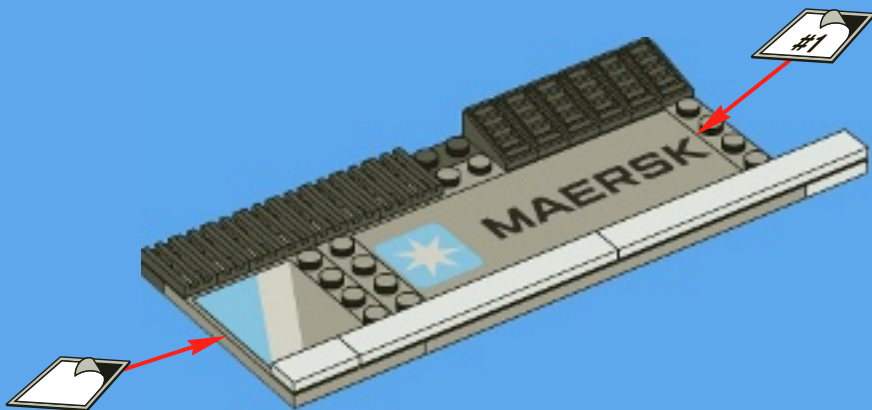

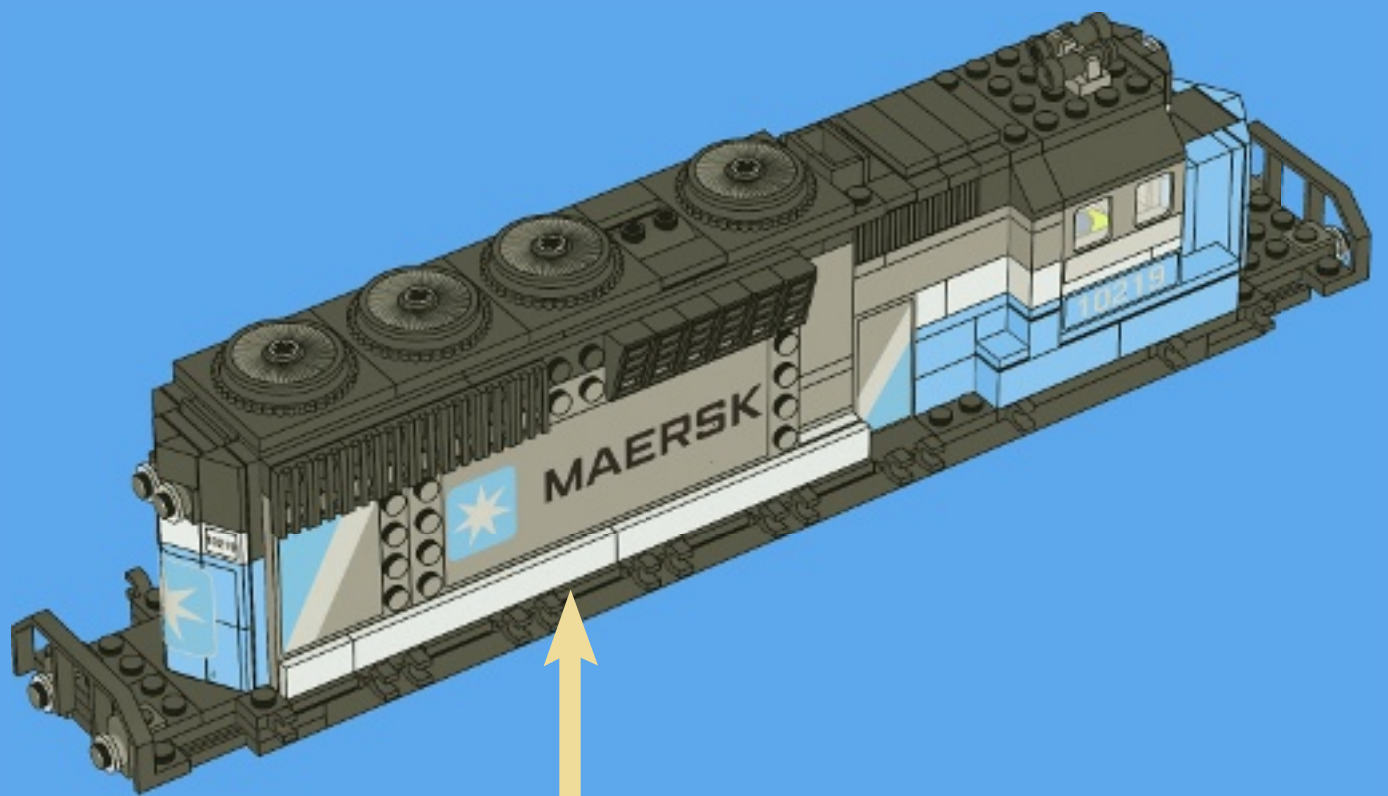



45

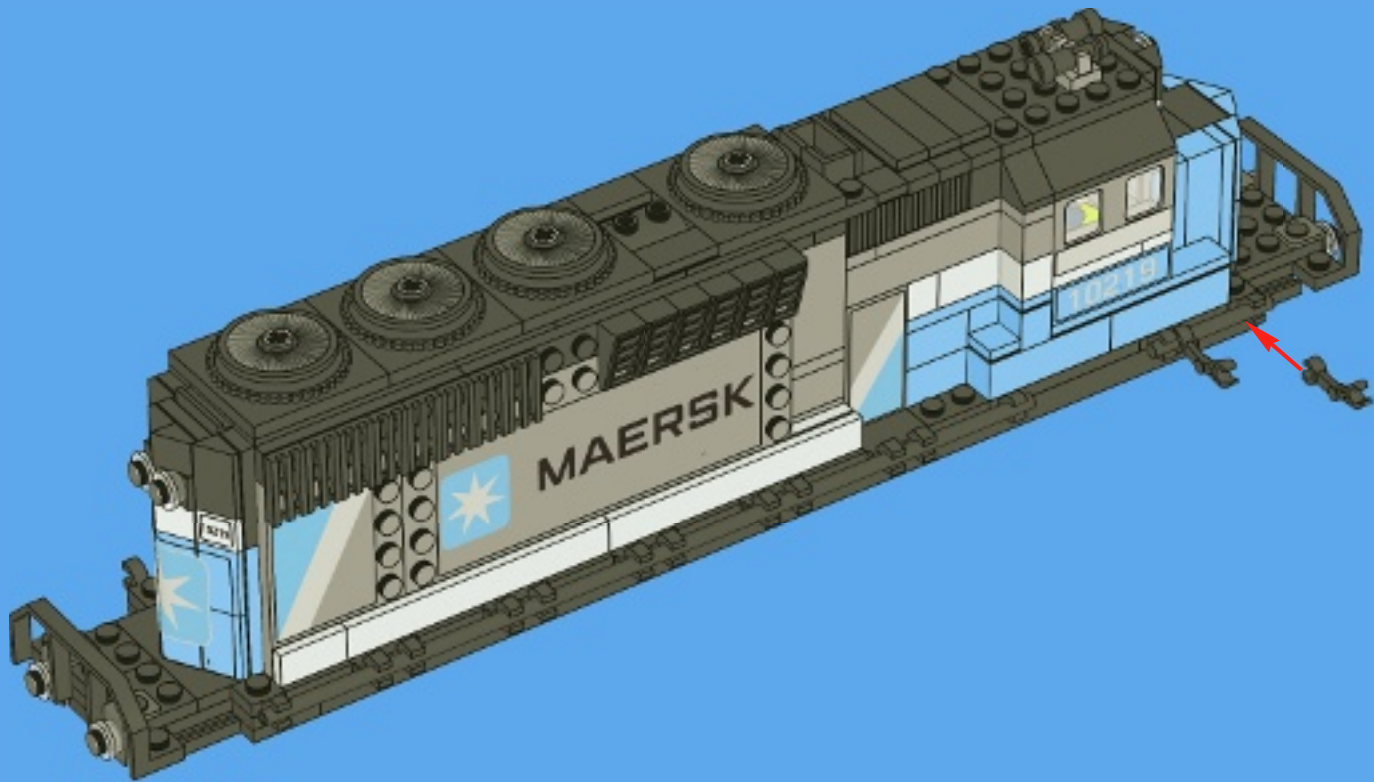





46

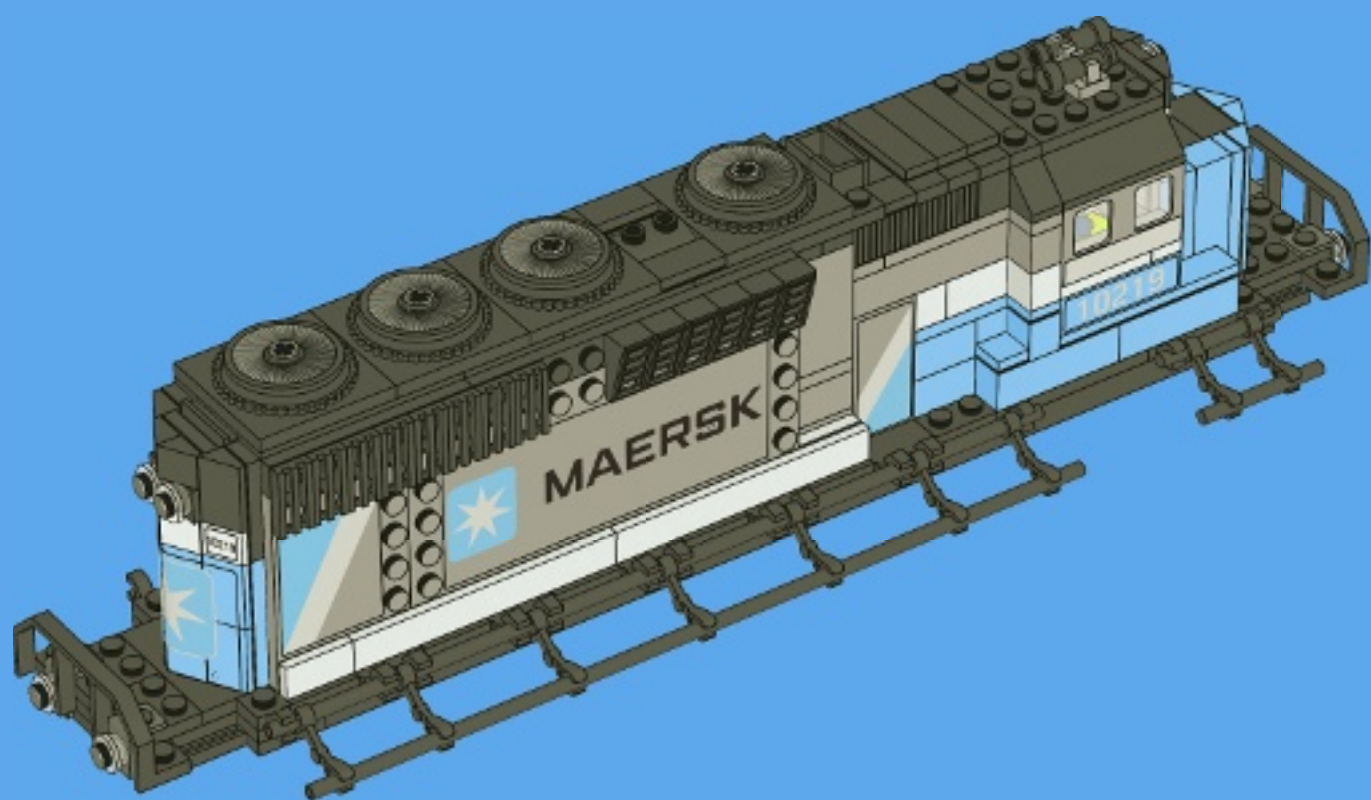

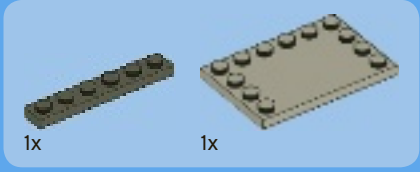
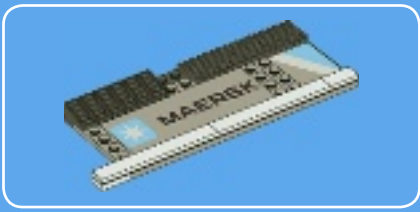

1

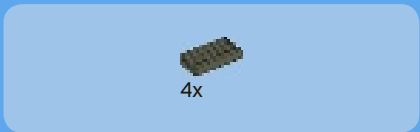

2

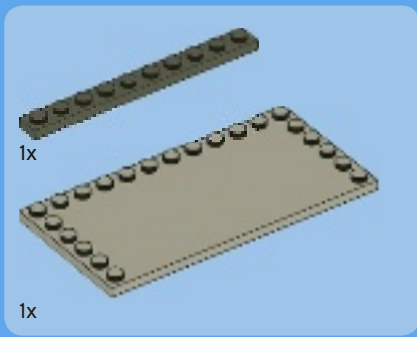
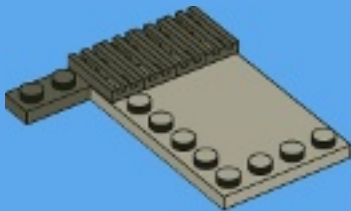

3

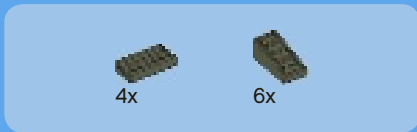
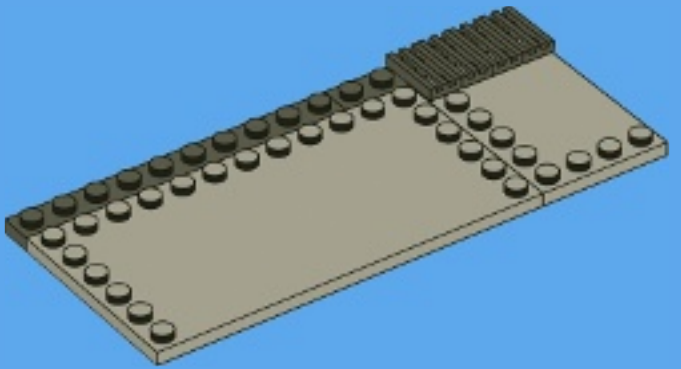

4

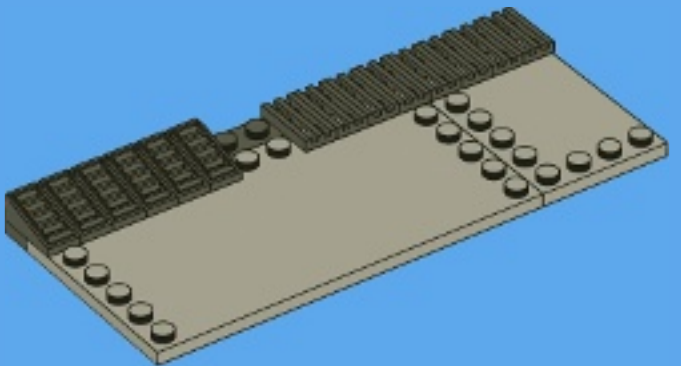

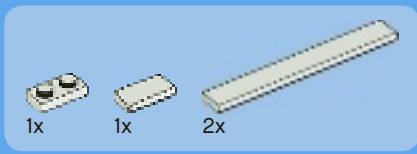

5

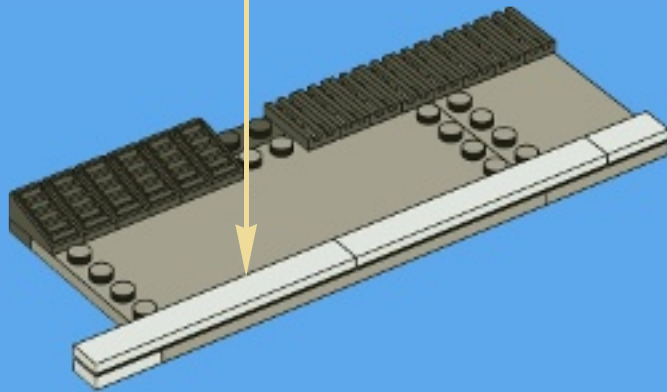
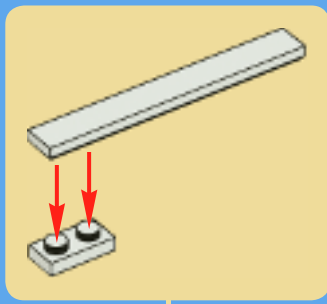

6

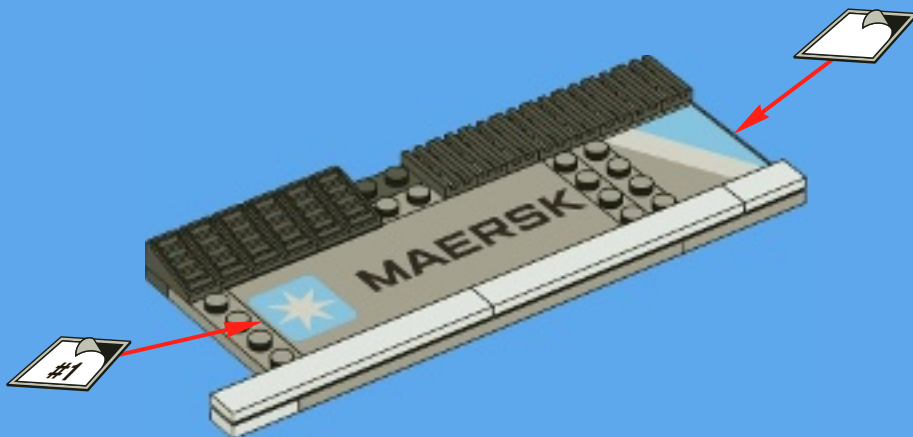

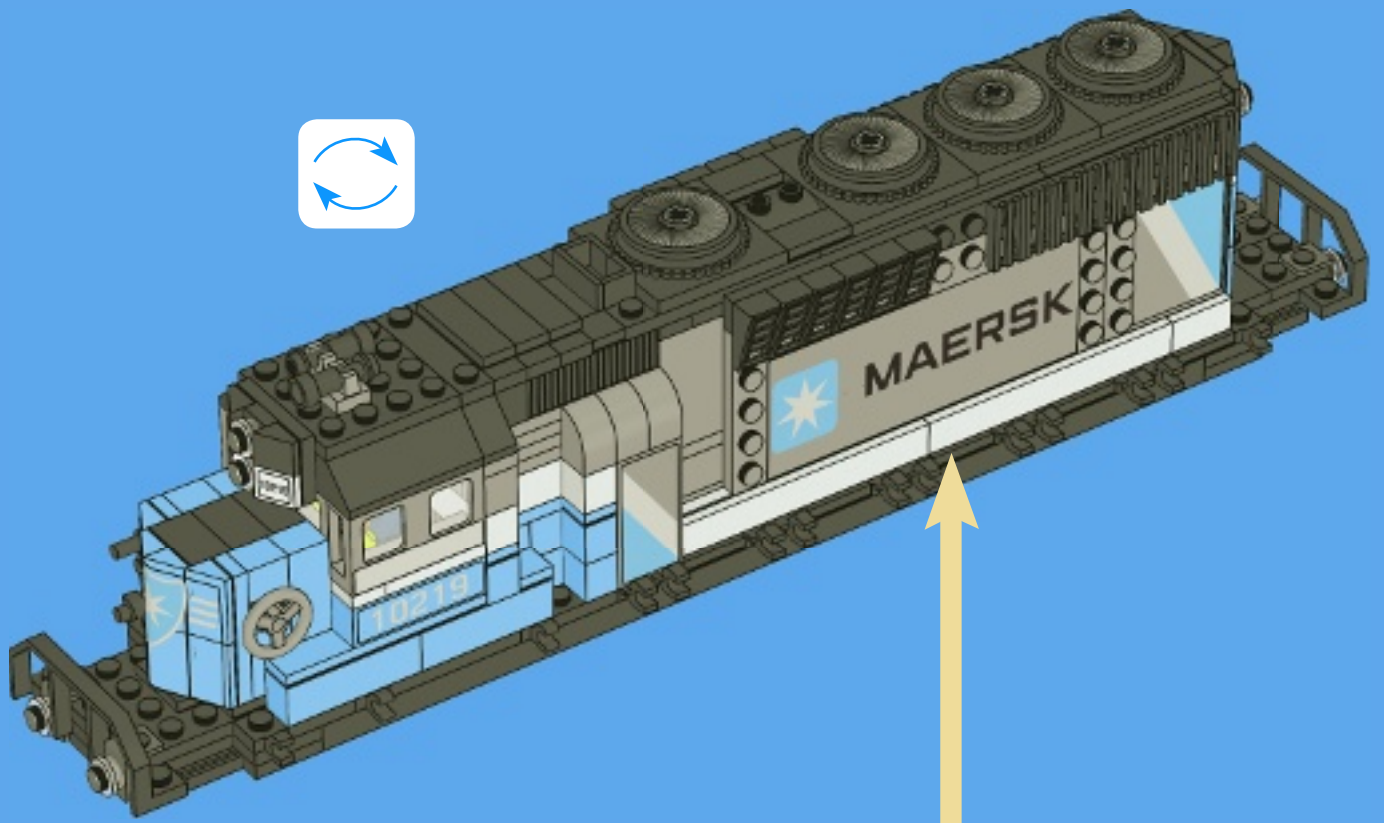



48

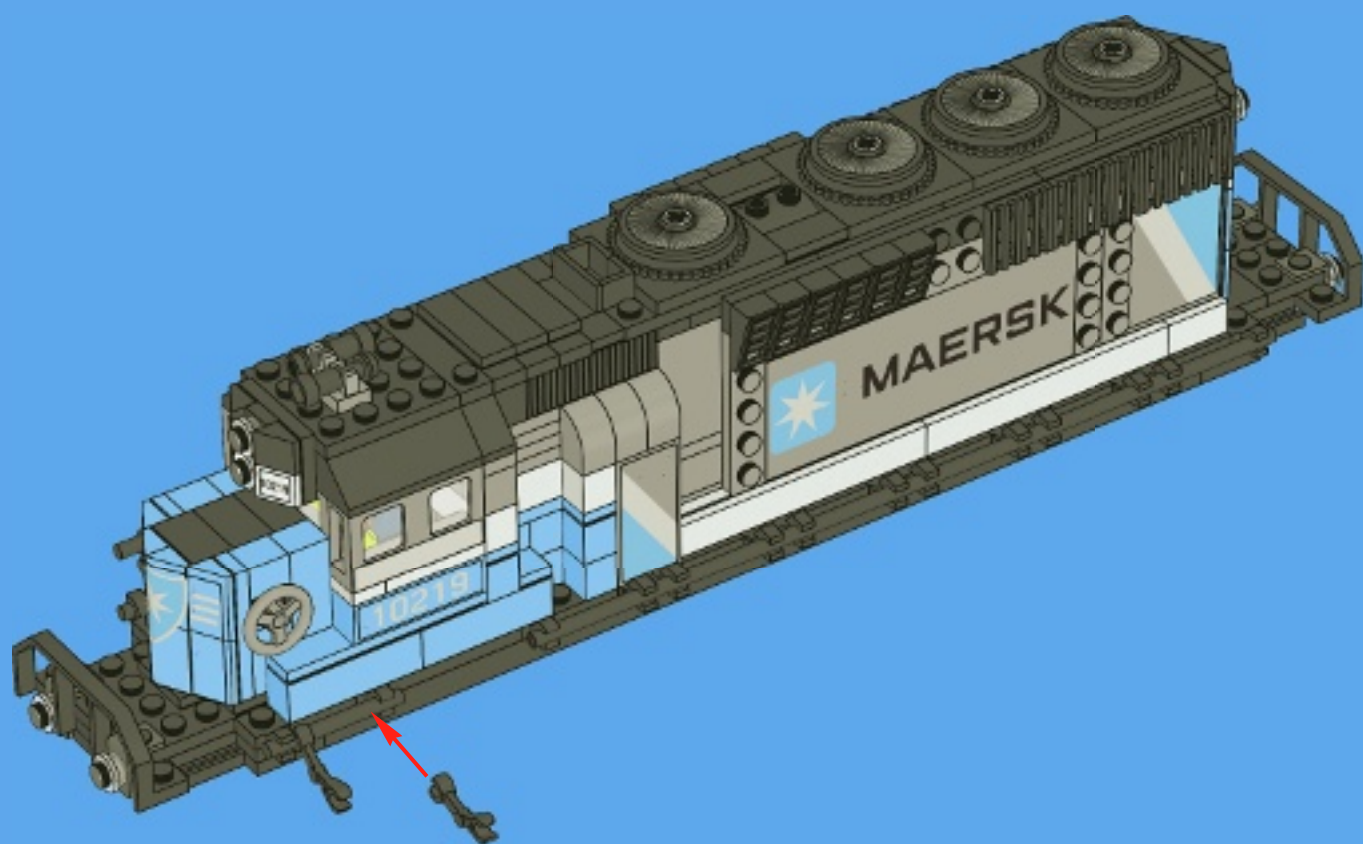

1x 7x

1x

# 49

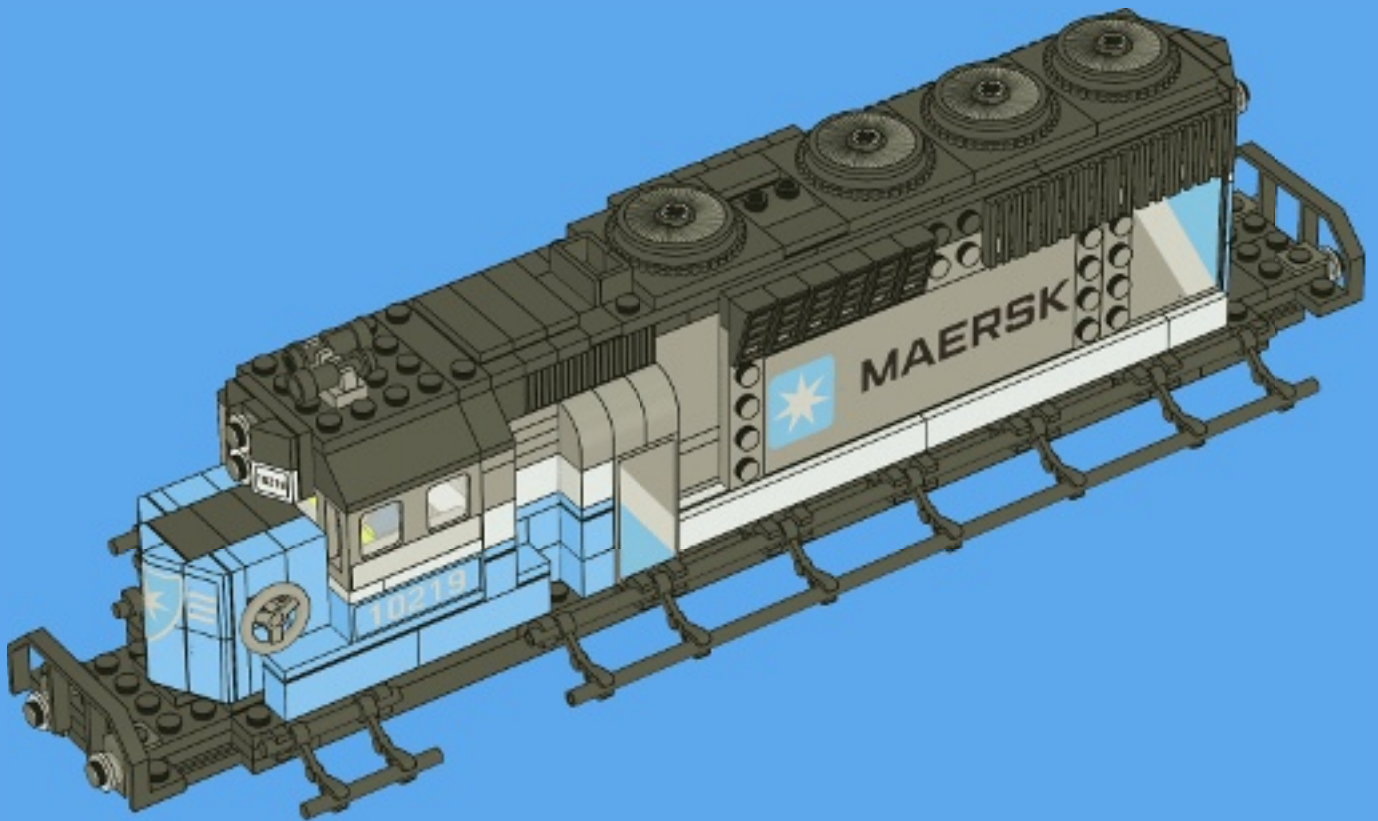

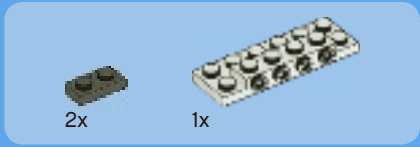

1

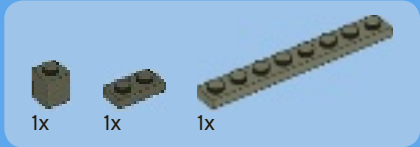

2

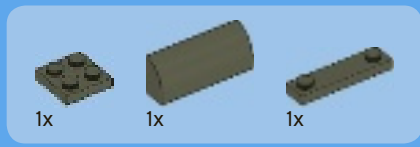

3

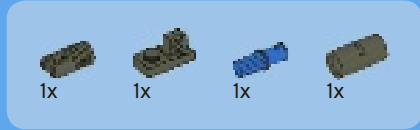
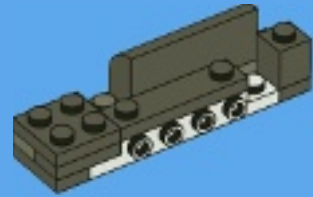

4

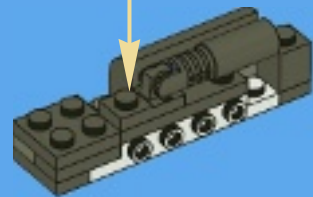
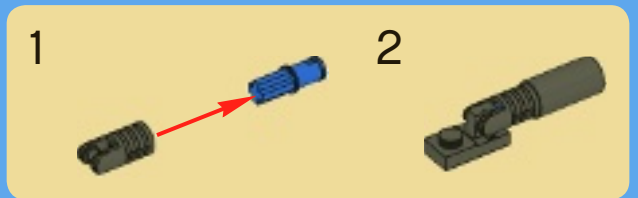



2x



1x

5

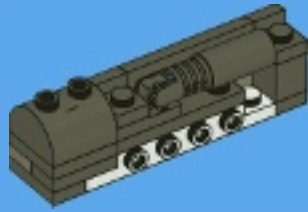

1x



1x



1x

6



2x



1x



4x

7

1

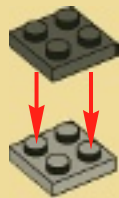

2

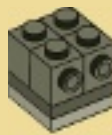

3

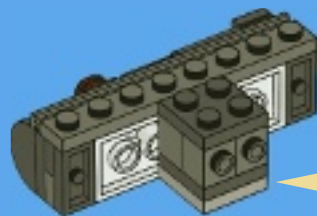



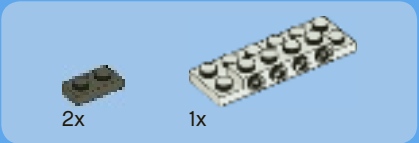

1

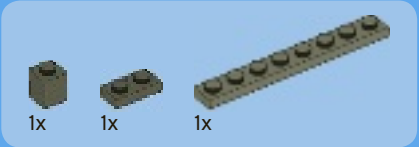

2

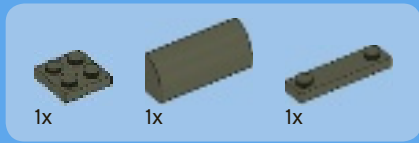
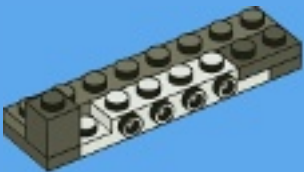

3

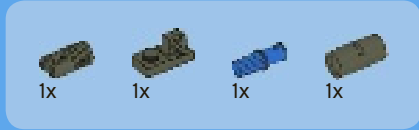
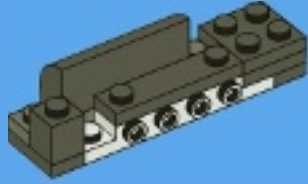

4

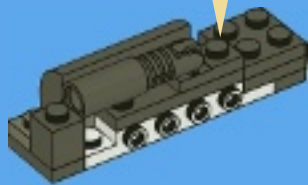



2x



1x

5

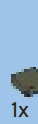
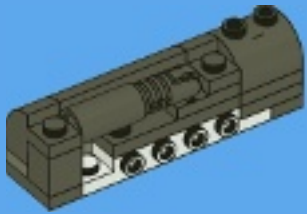

1x



1x



1x

6

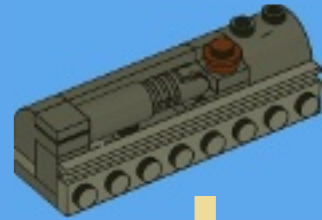

8

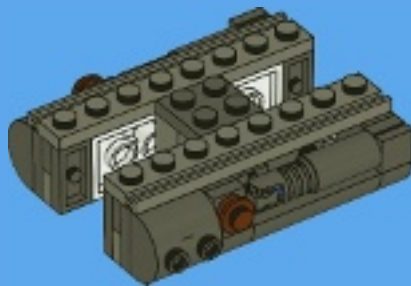



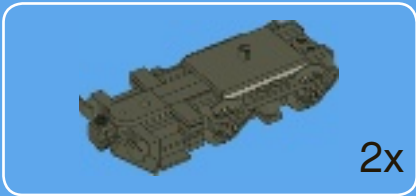

1

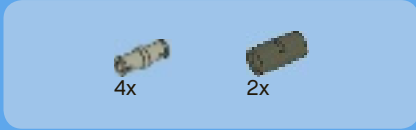
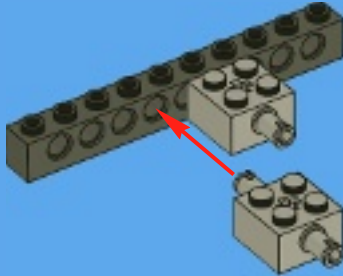

2

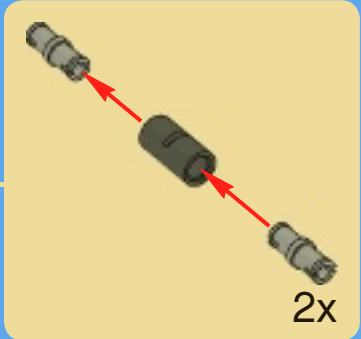
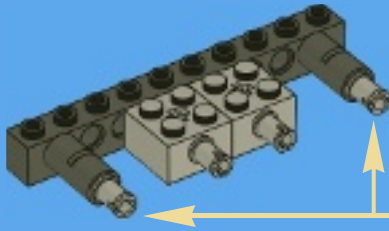

3



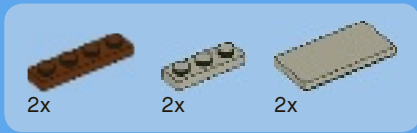

4

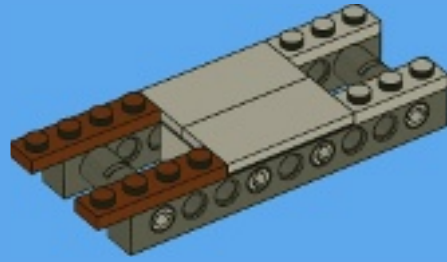

5



6

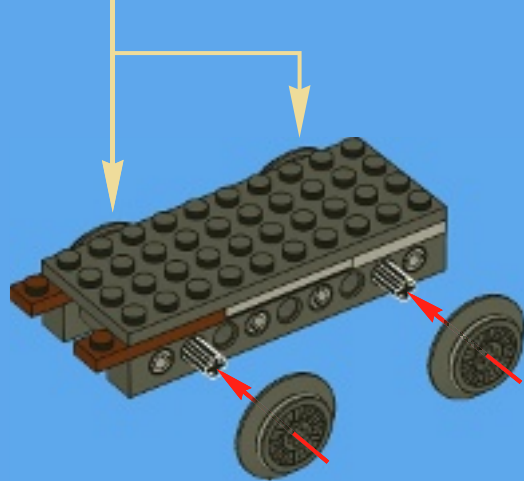



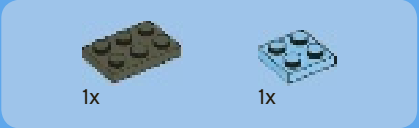

1

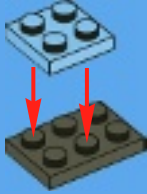

2



3

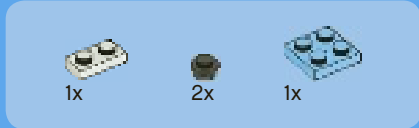

4



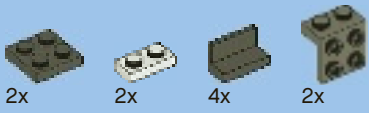

5

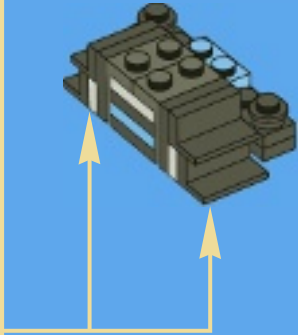
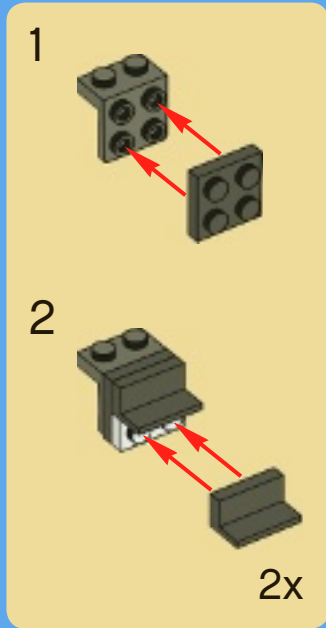

1x

6



10

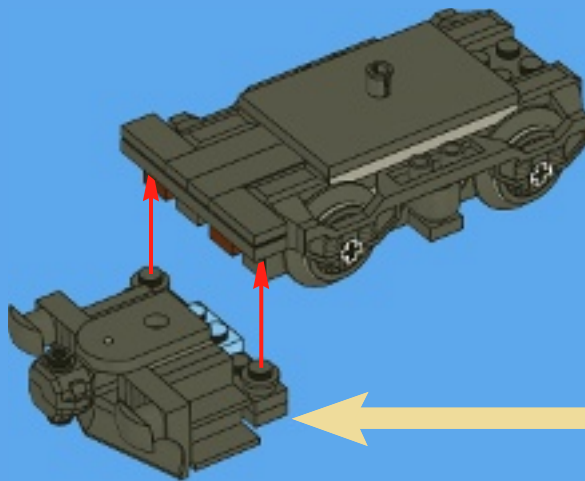

2x



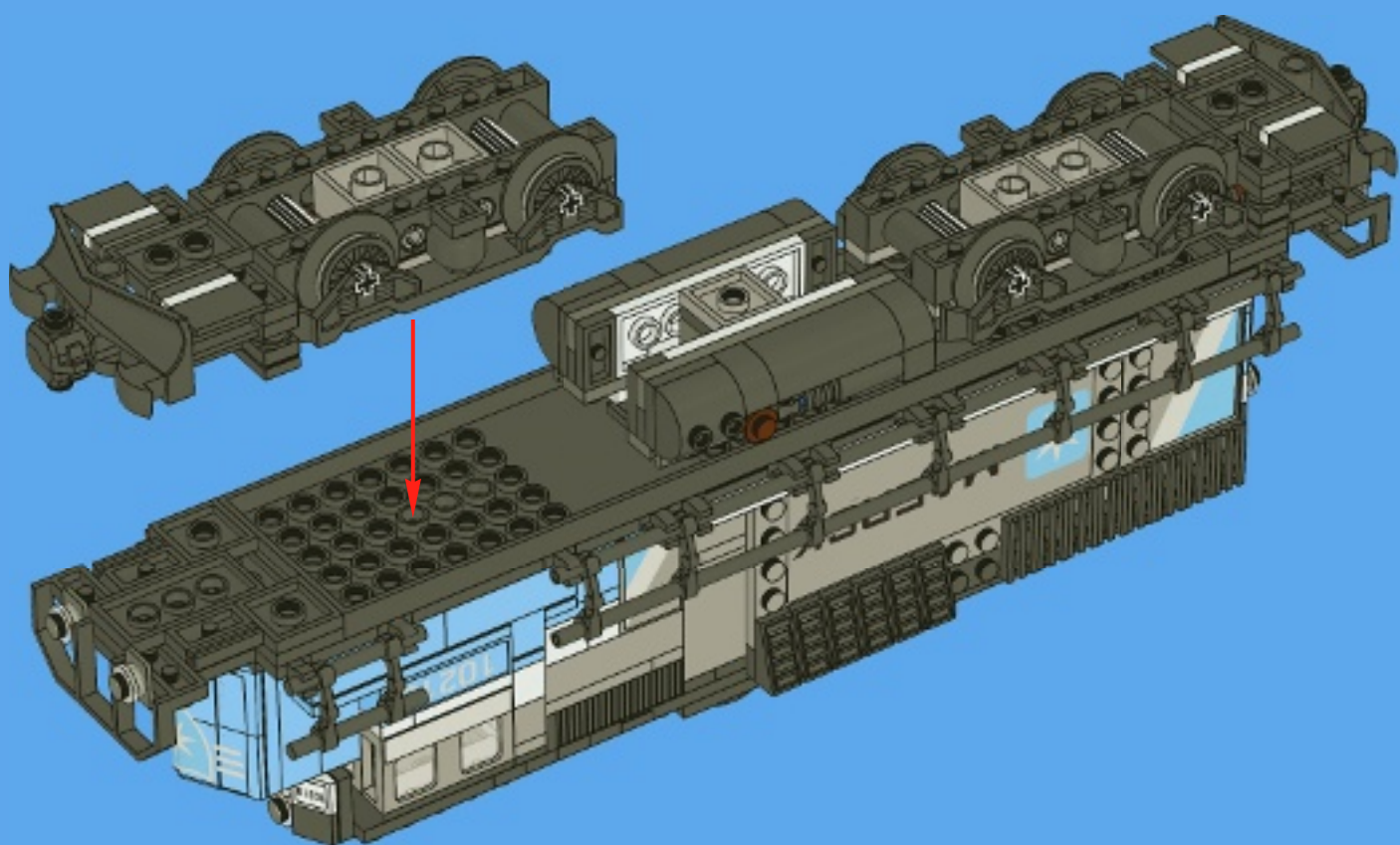

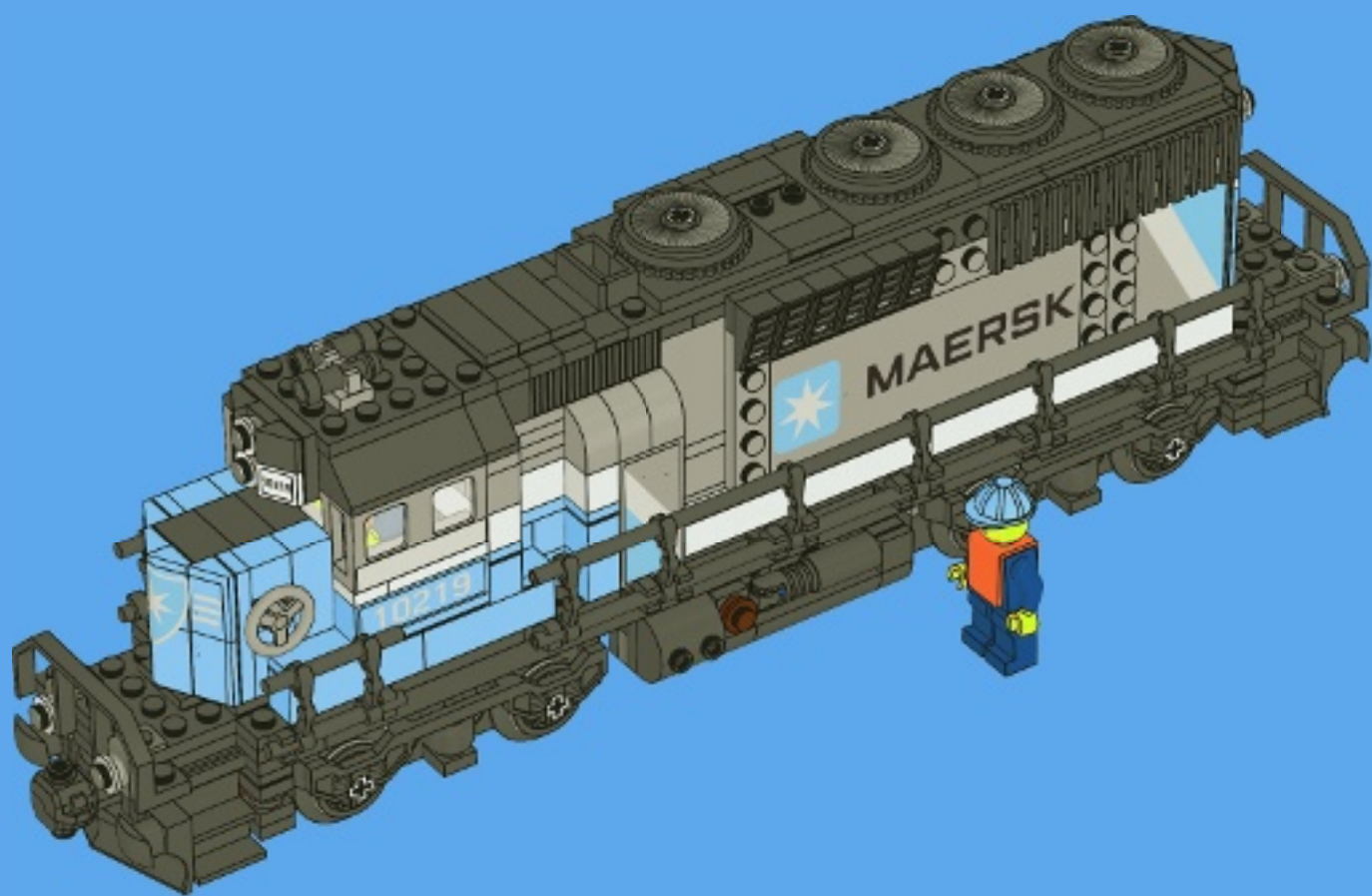

10211



10214



LEGO and the LEGO logo are trademarks of the LEGO Group. ©2011 The LEGO Group.  
©2011 Lucasfilm Ltd. & TM. All rights reserved. 4654998



10219





2

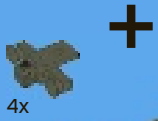

4x

2x

6x

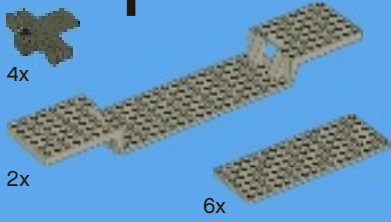

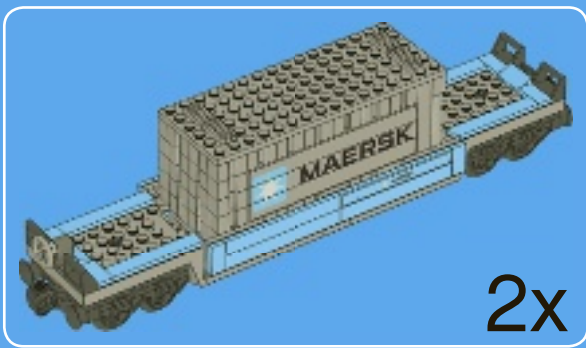

2x

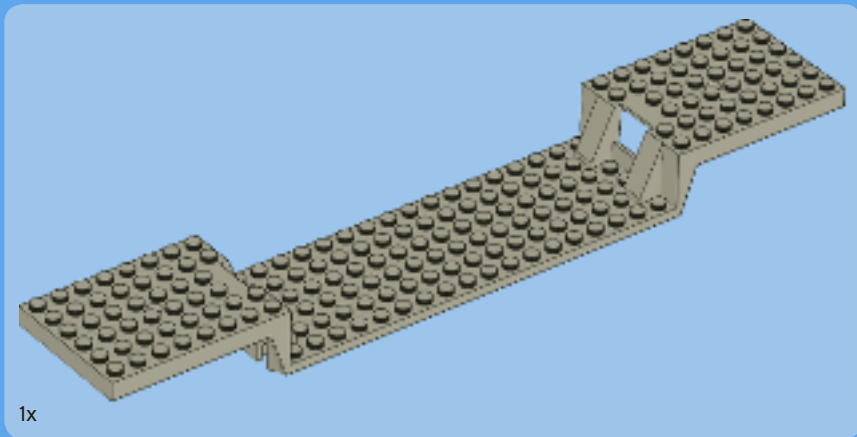

1x

1

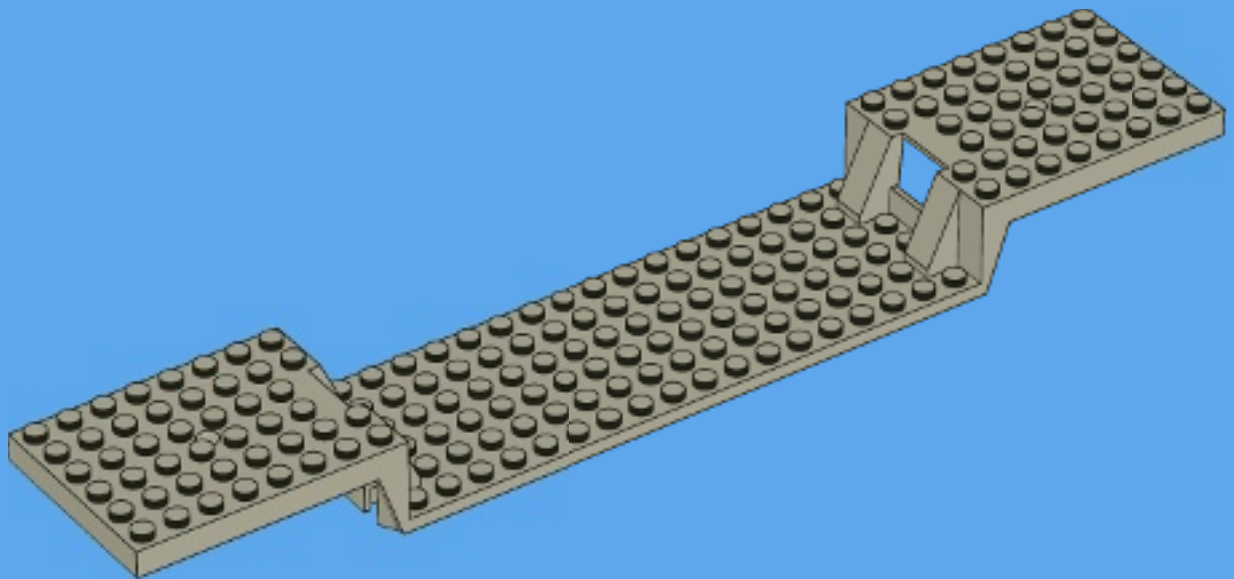



4x



2x

2

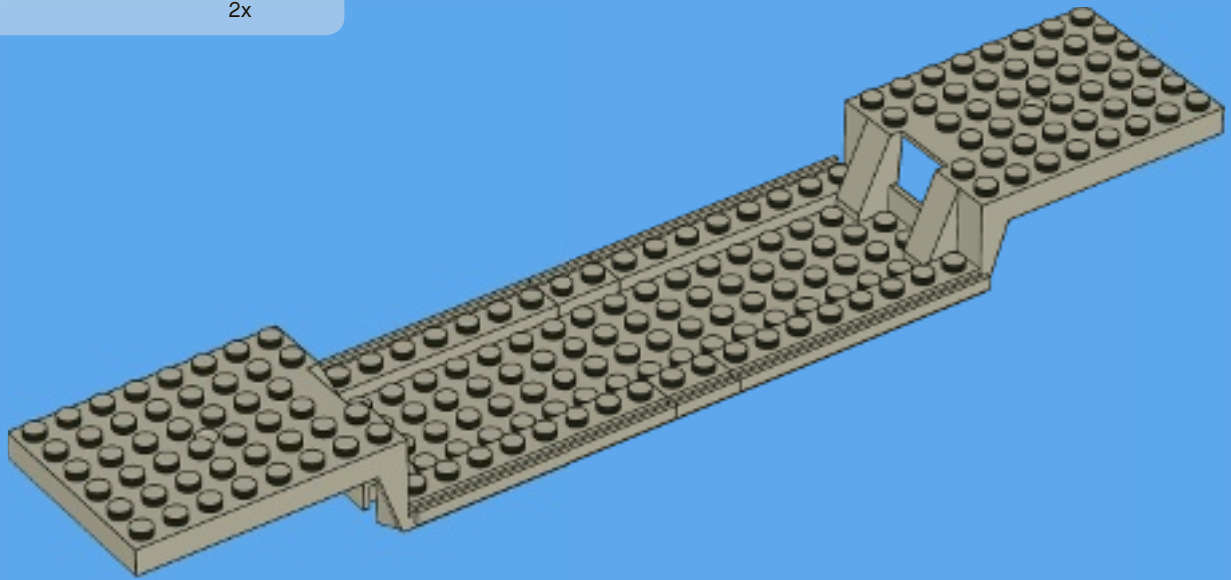

3x

3

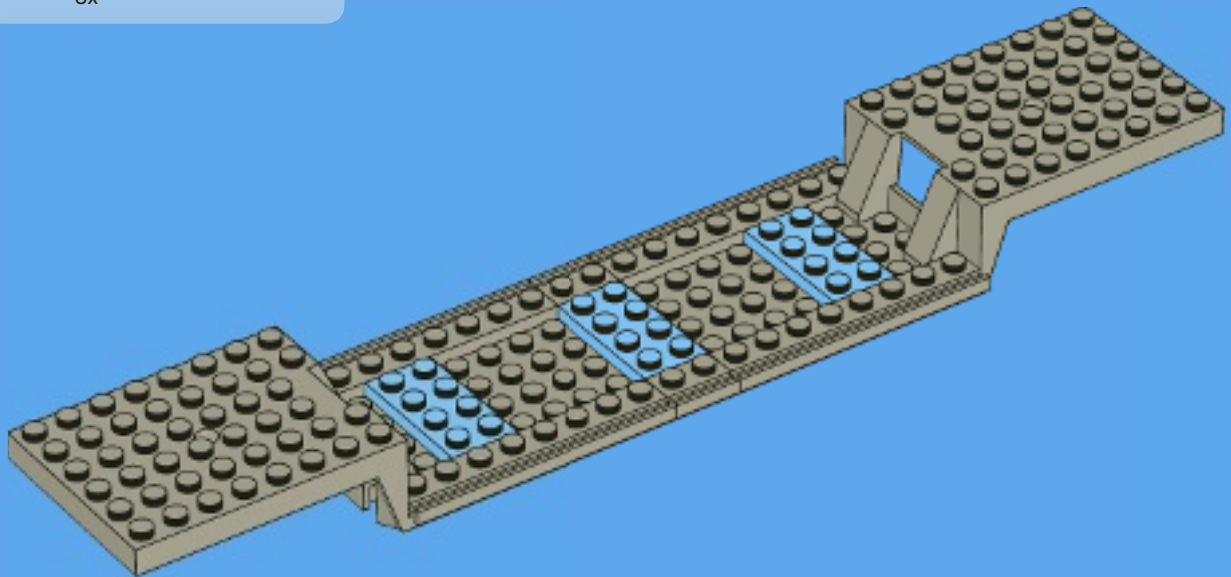





4x



4x



4x

# 4

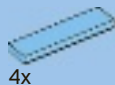
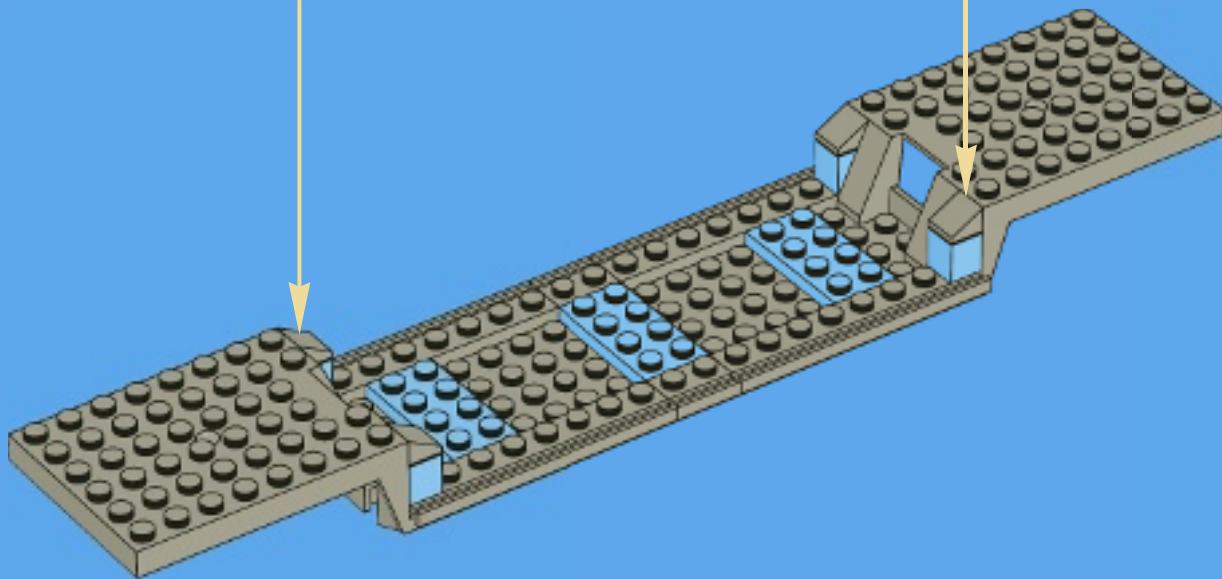

4x



4x

# 5

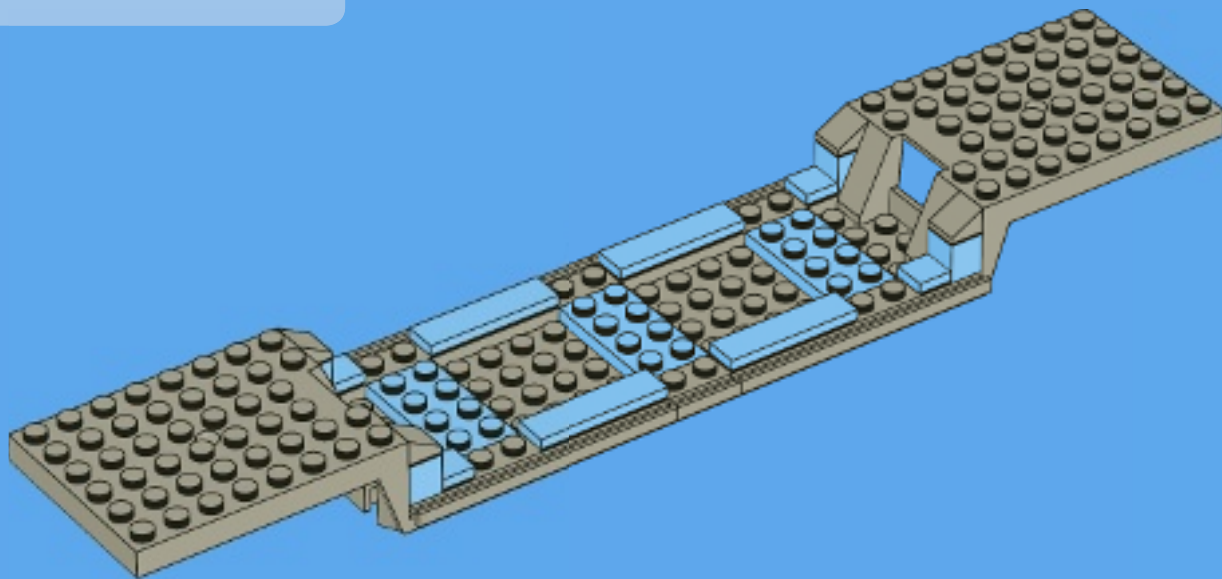



6x

# 6

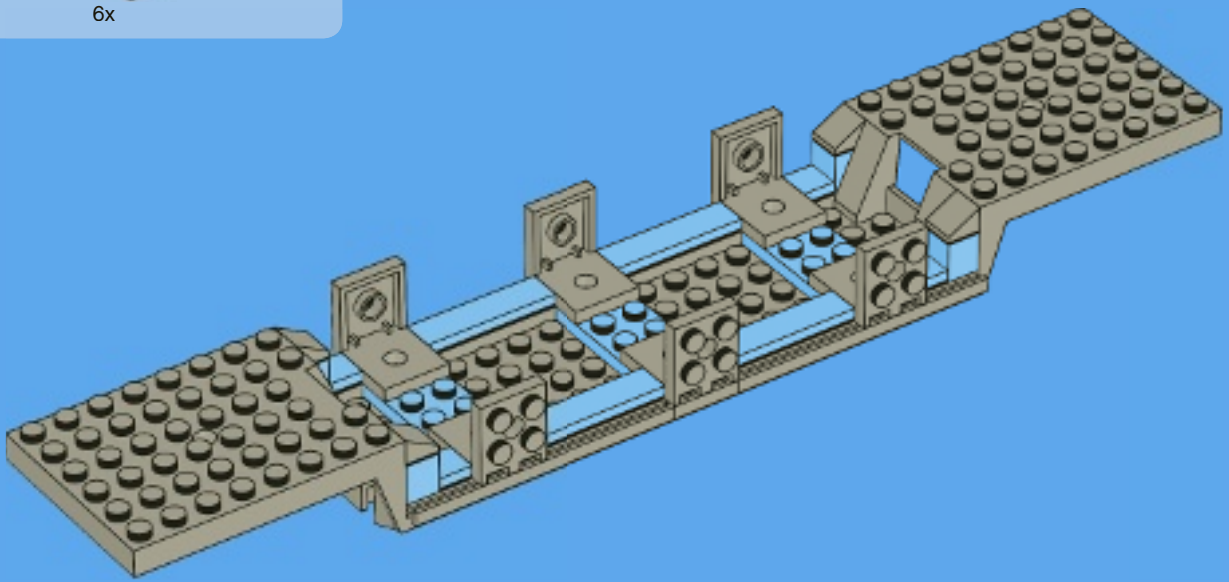

4x



4x



8x



1:1

# 7

1

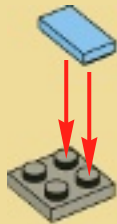

2

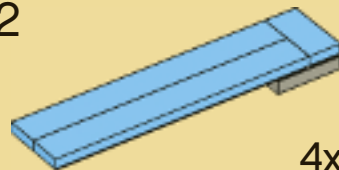

4x

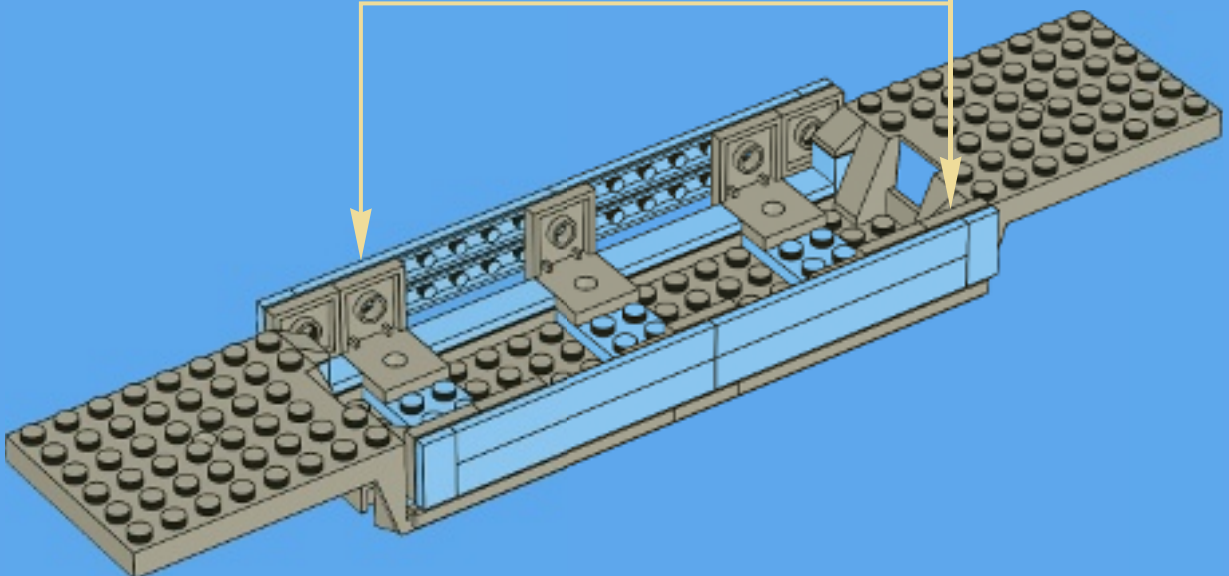

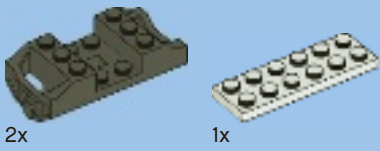

1

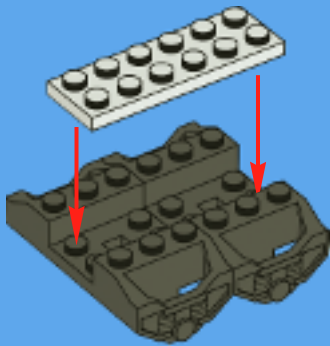

2



3

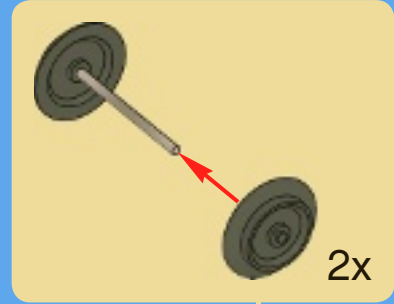

4



2x

8

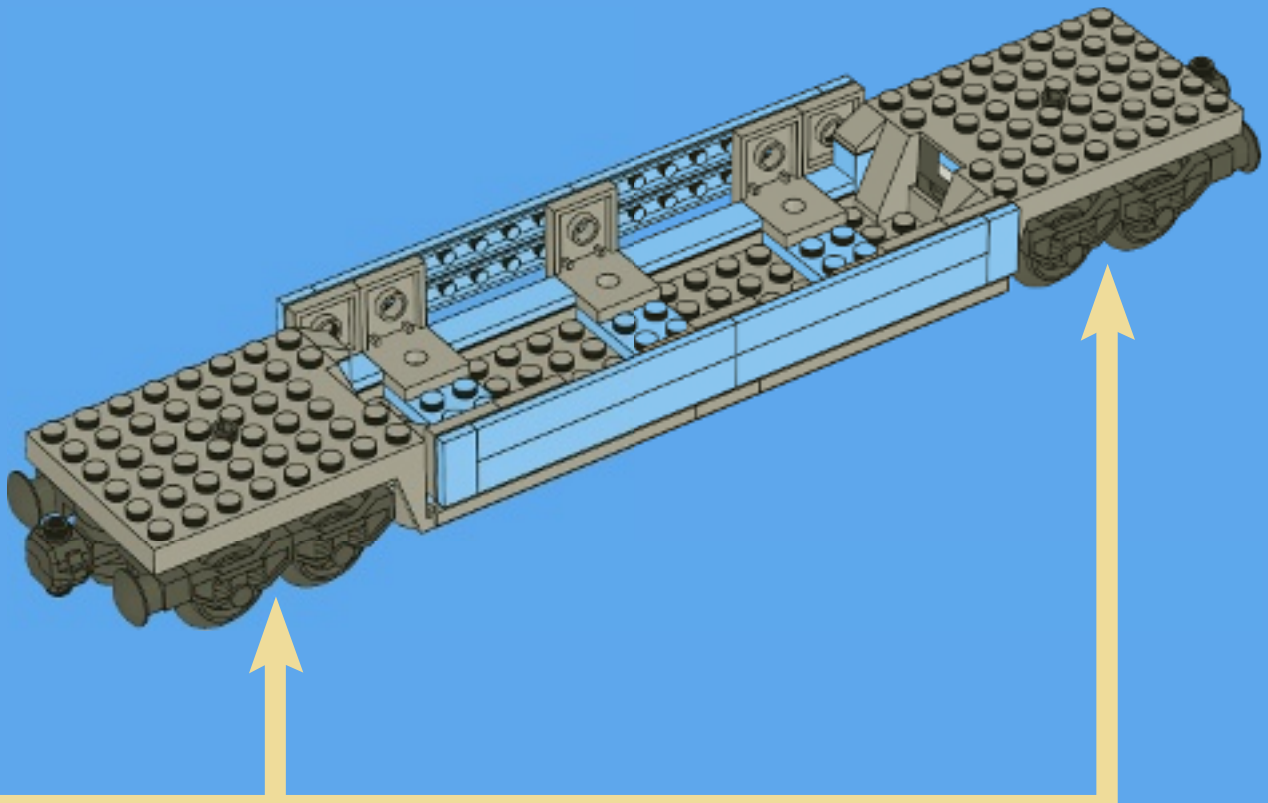

1x

2x

9

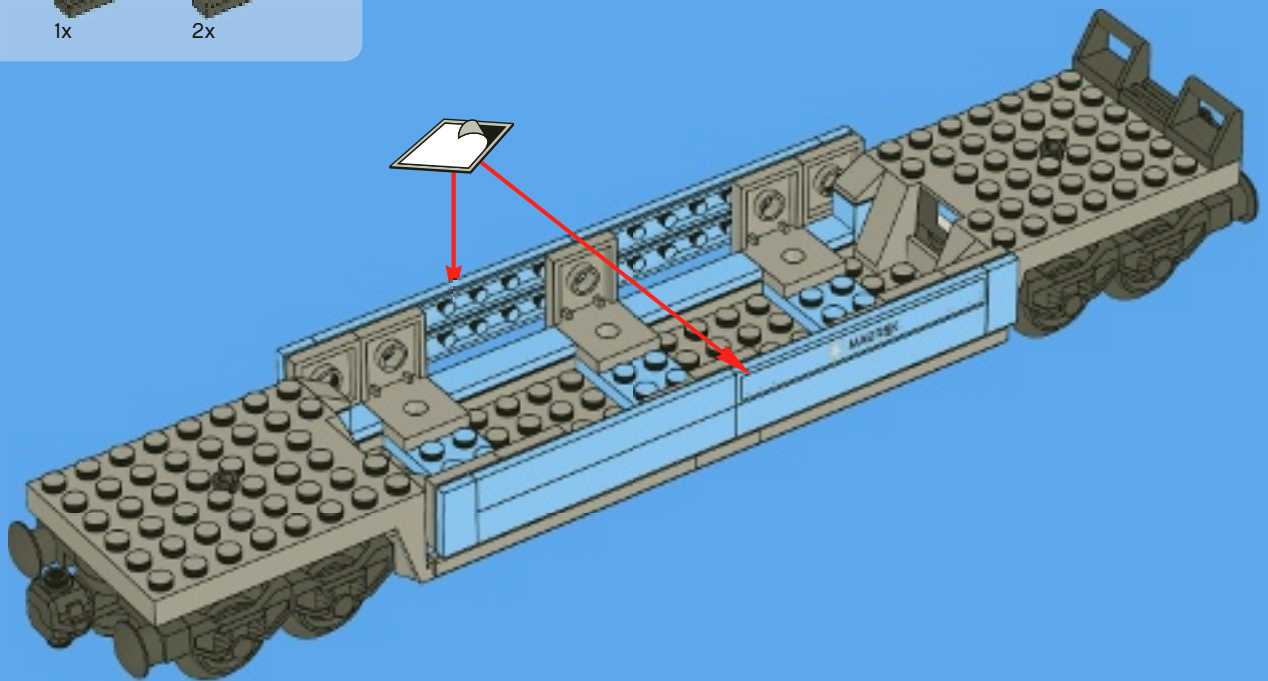



10

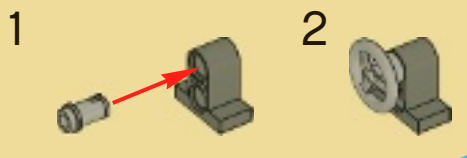
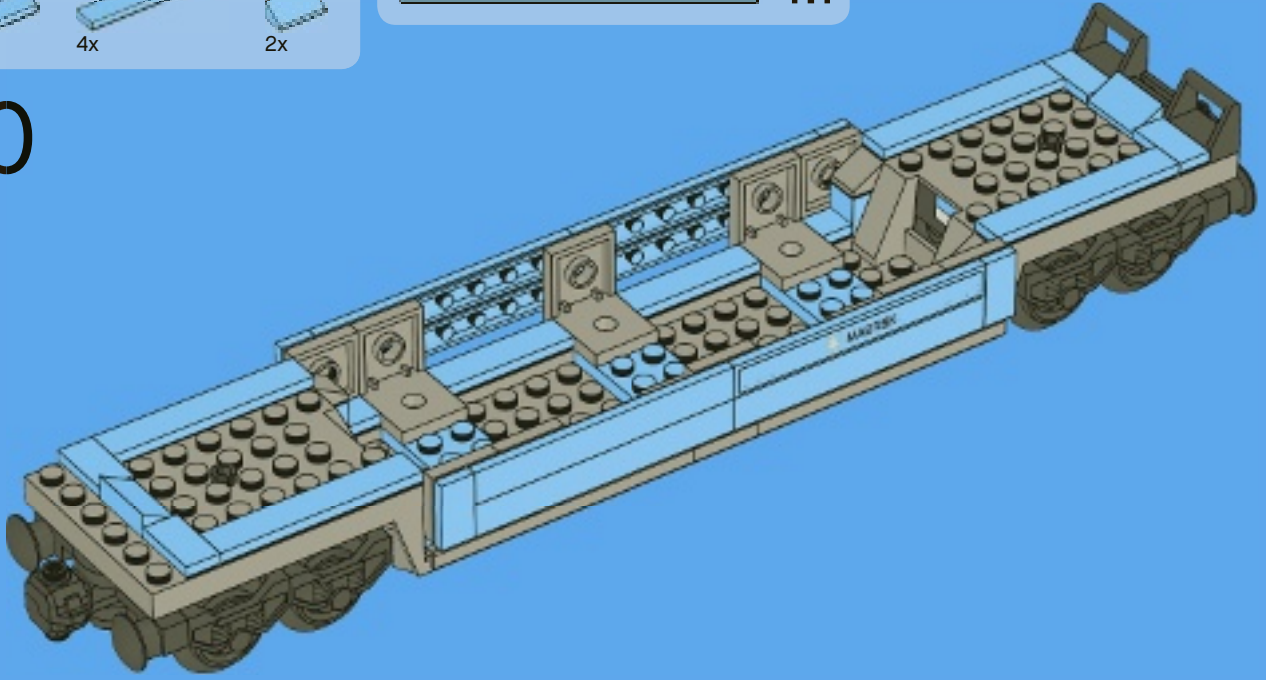

11

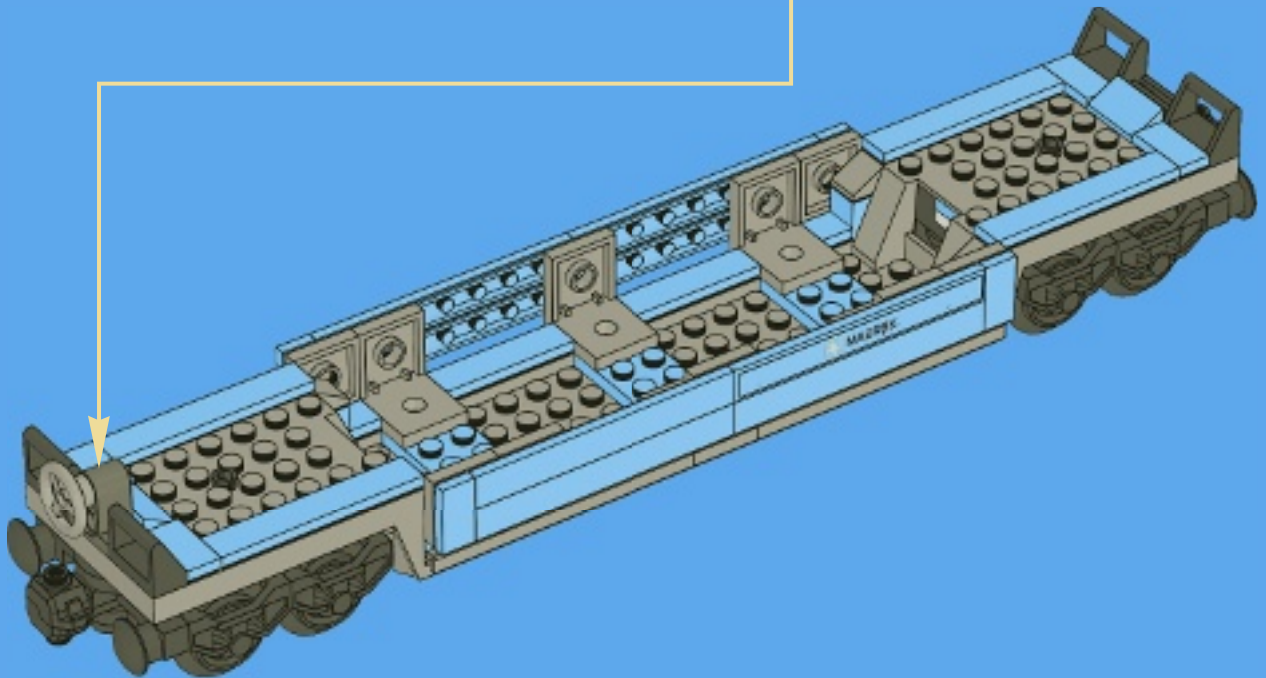

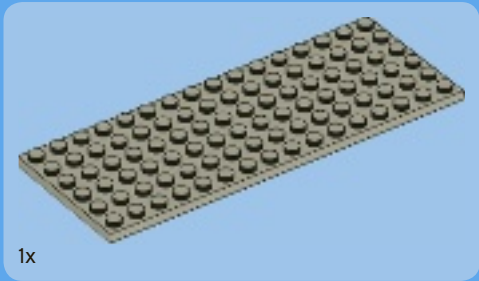

1x

1

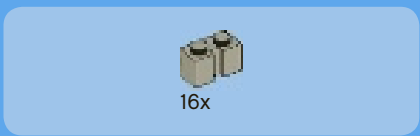
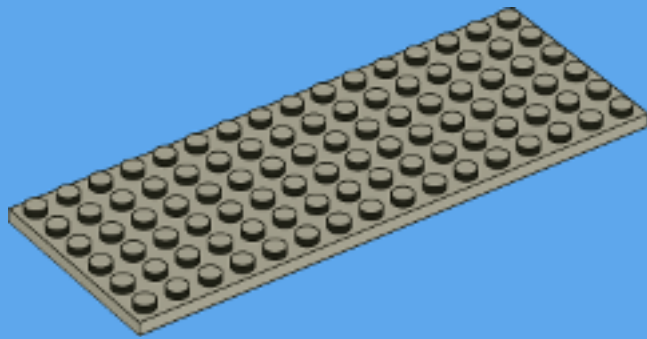

16x

2

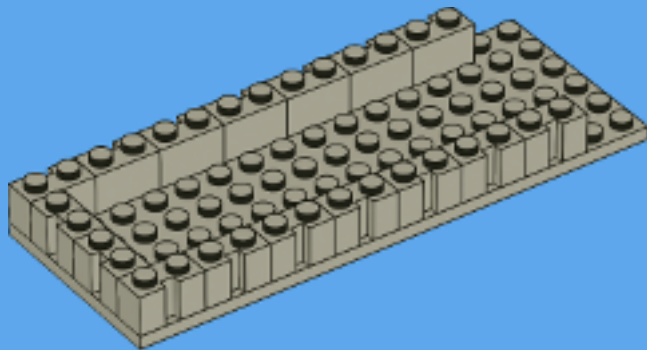

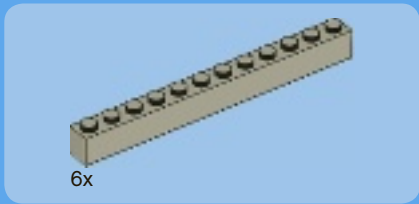

3

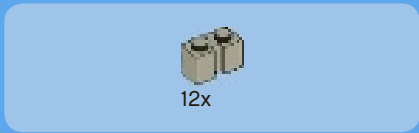
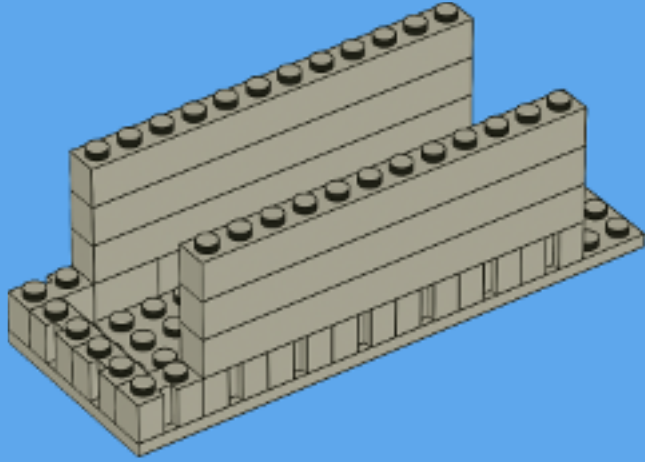

4

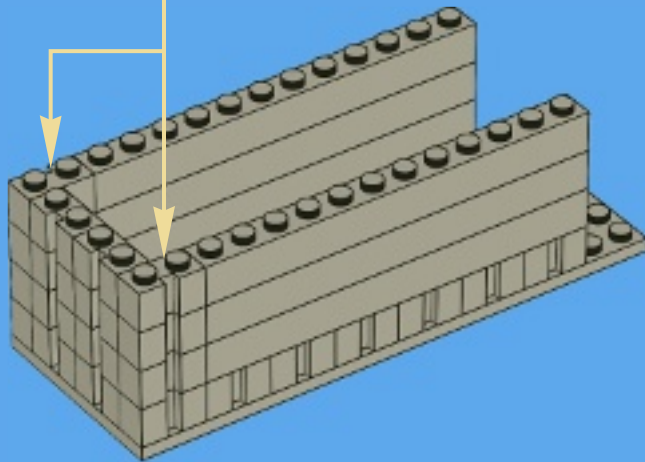
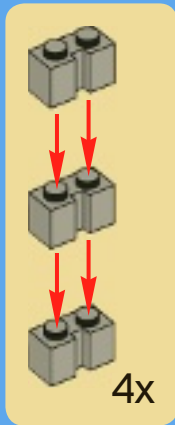

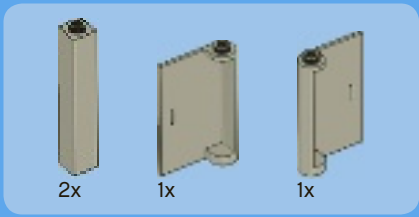

5

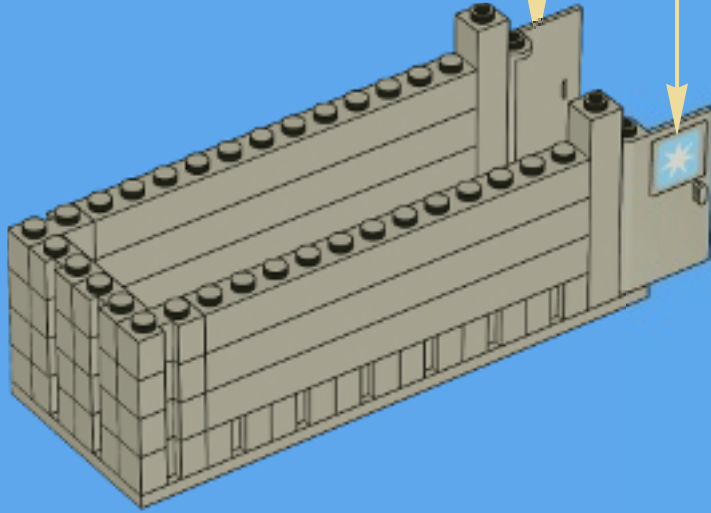
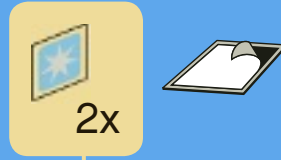

6

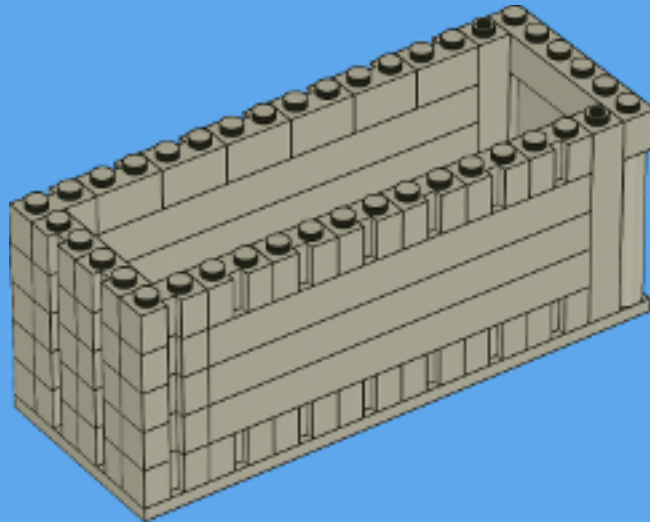



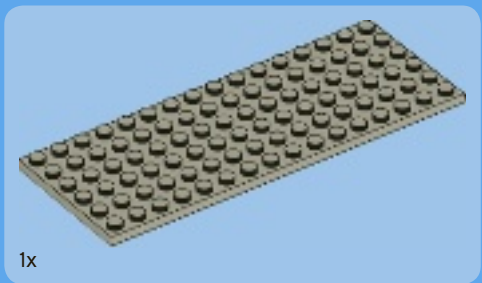

1x

7

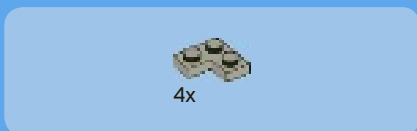
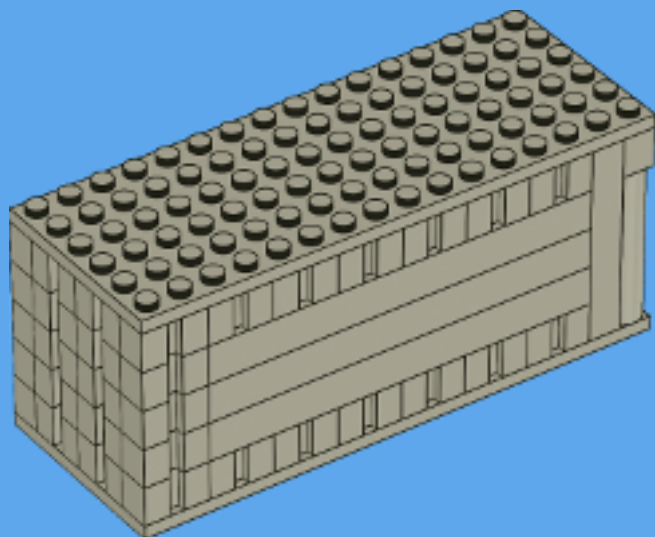

4x

8

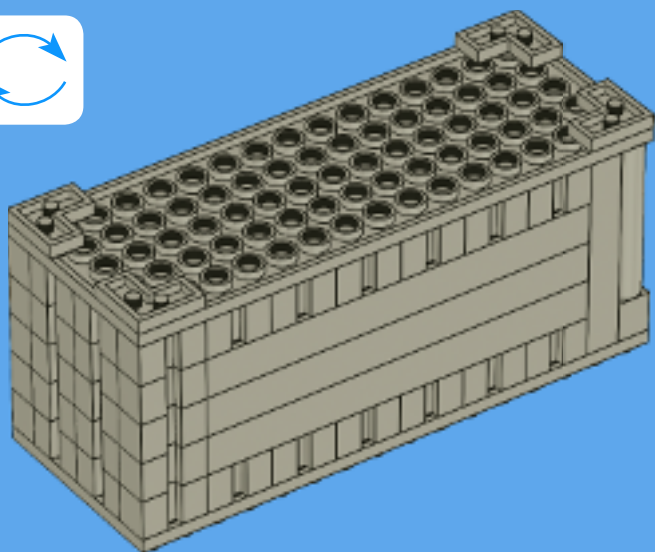



4x

9

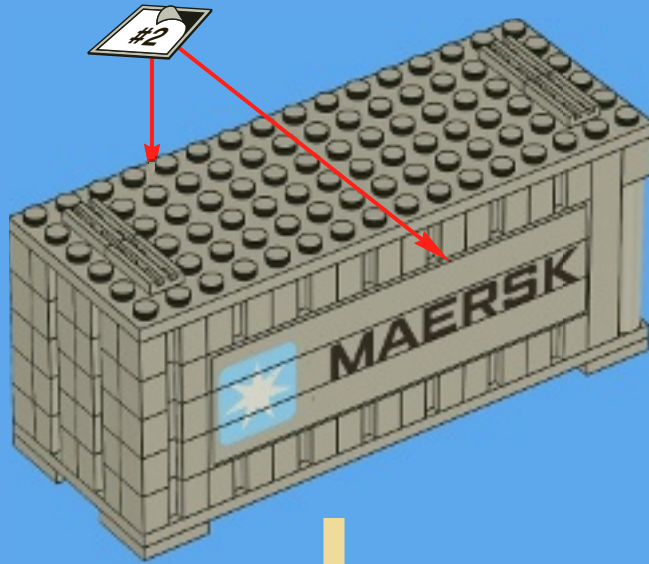

12

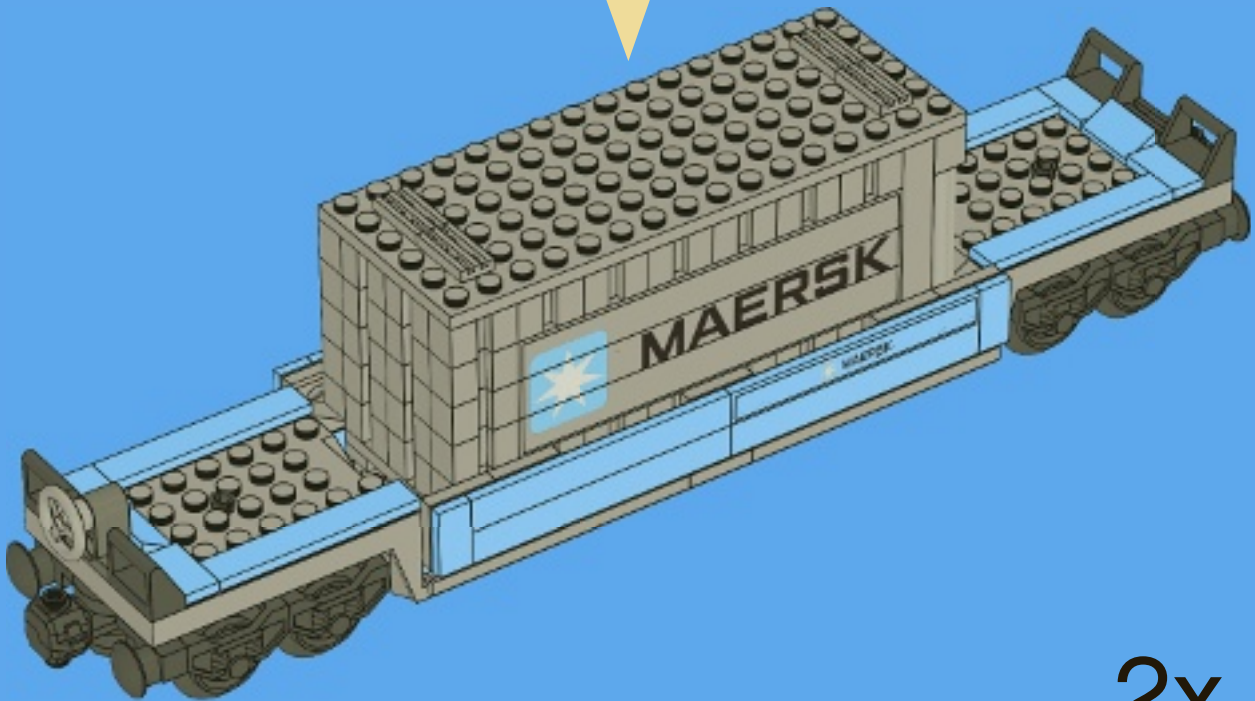

2x

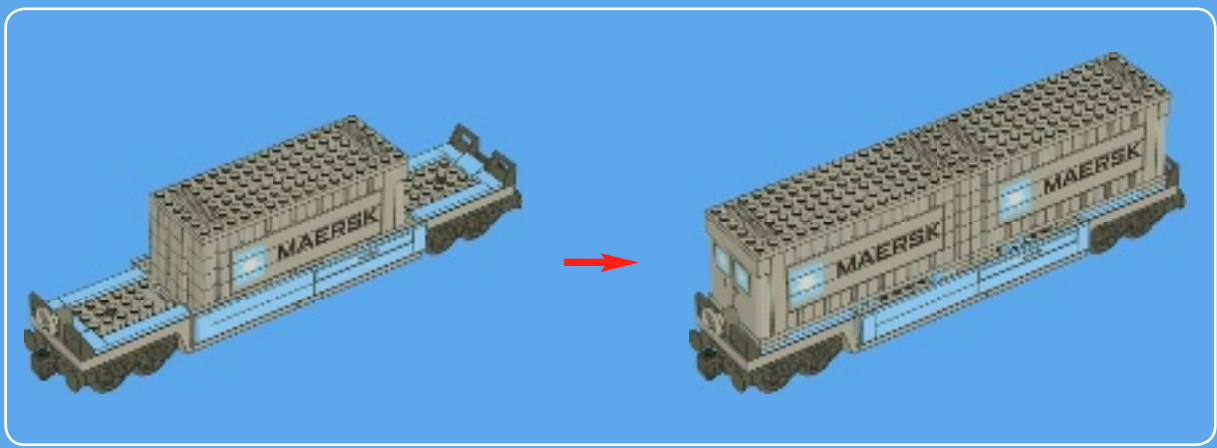

1

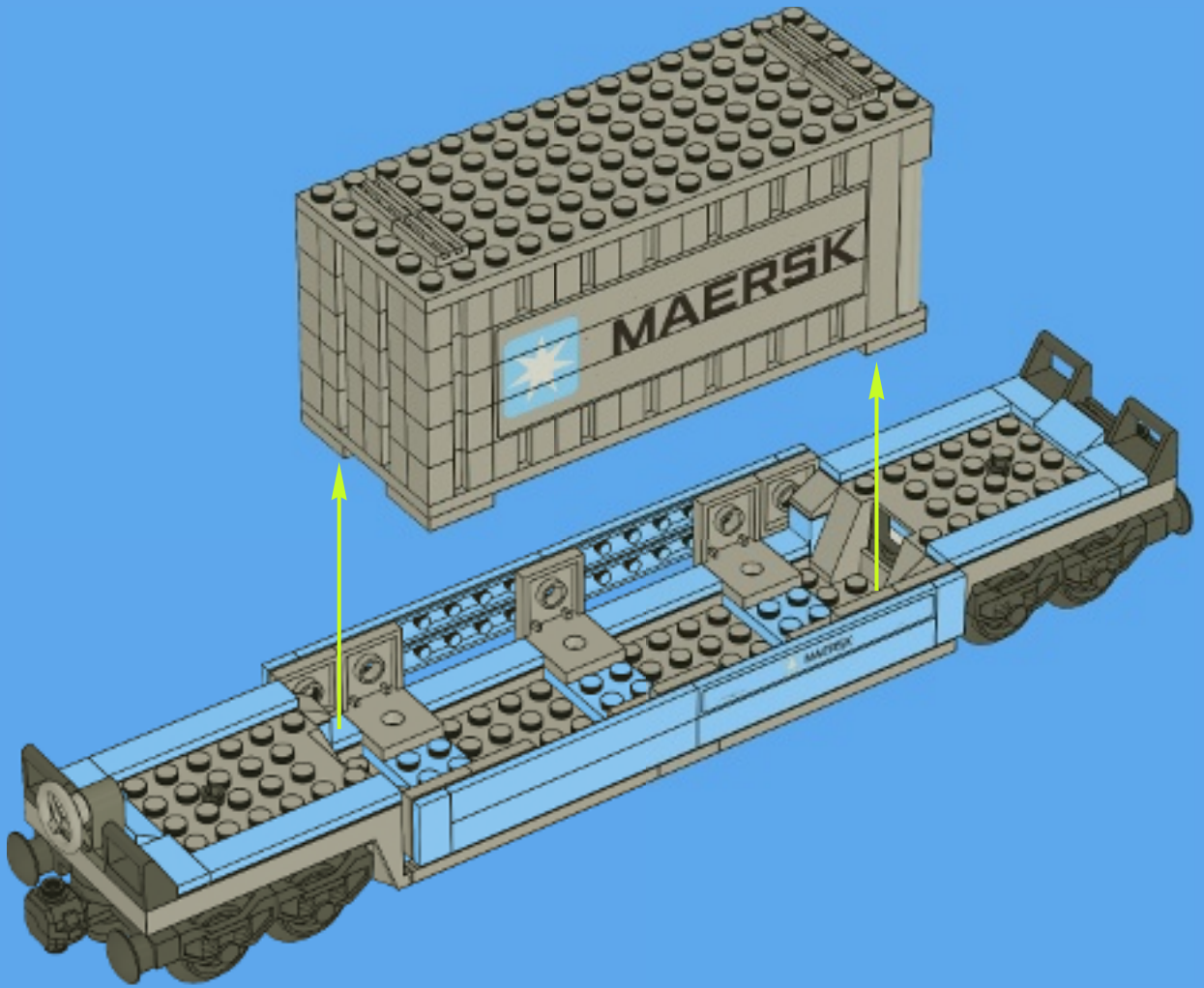



1x



2x

2

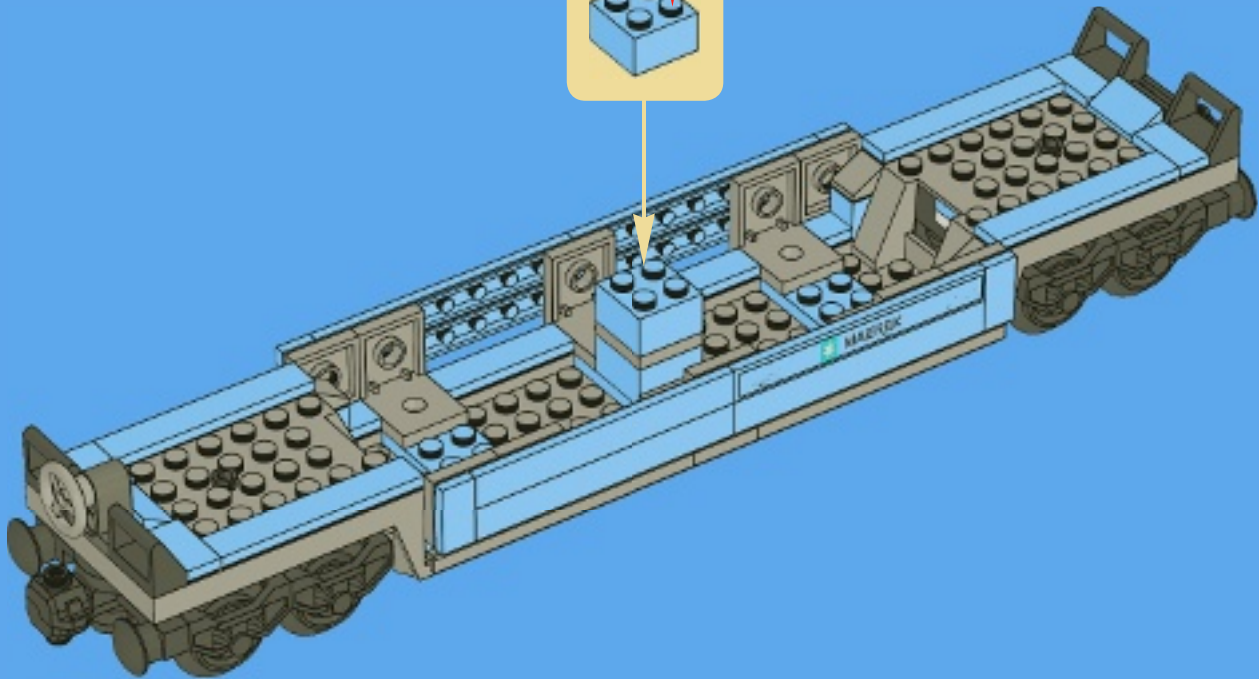
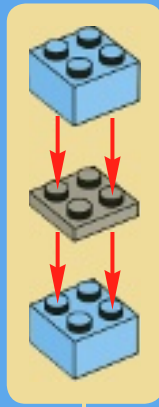

3

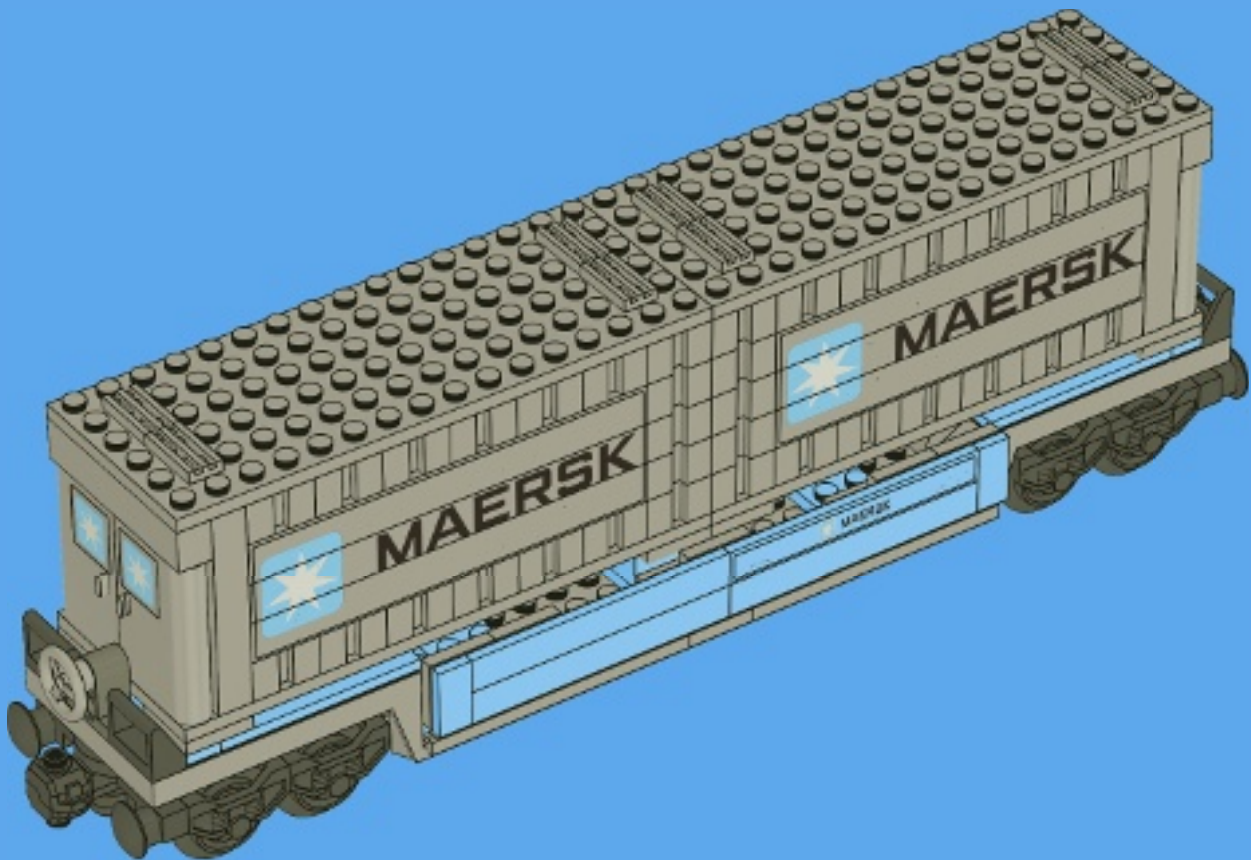

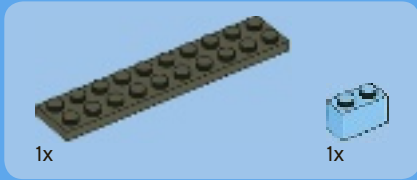

1



2

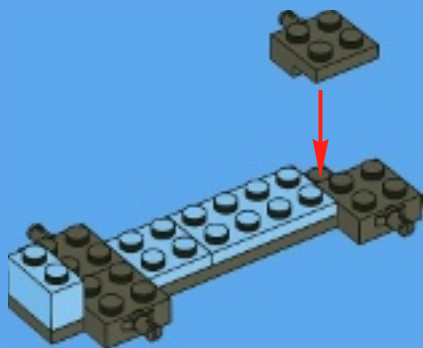

3

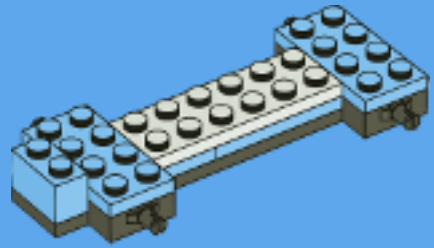

4

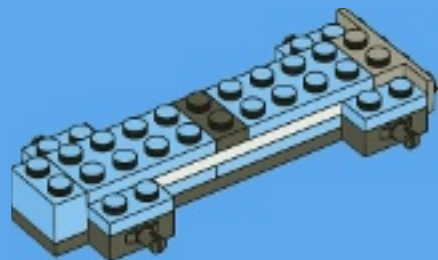

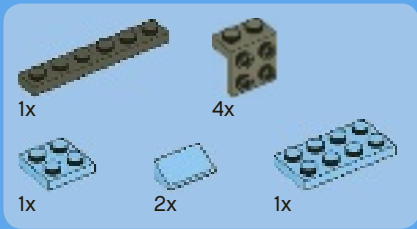

5

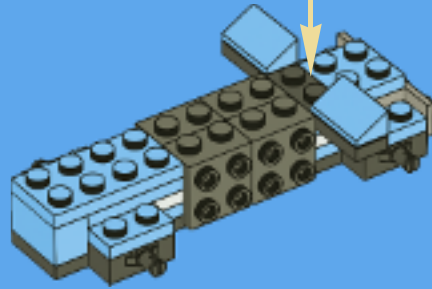
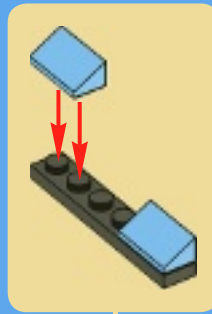

6

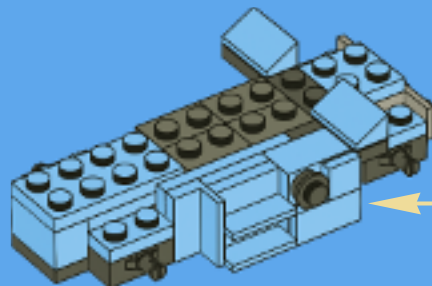
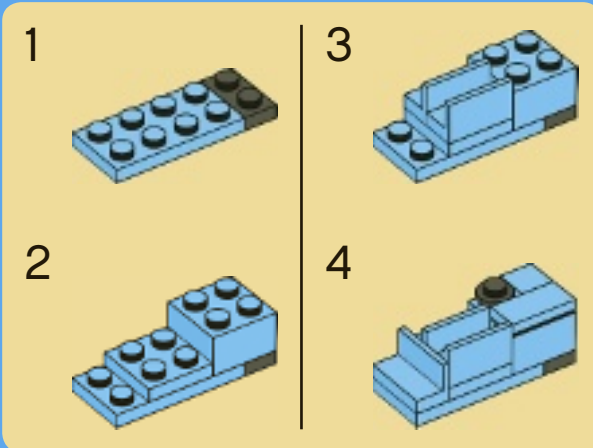

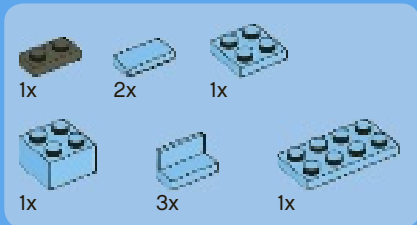

7

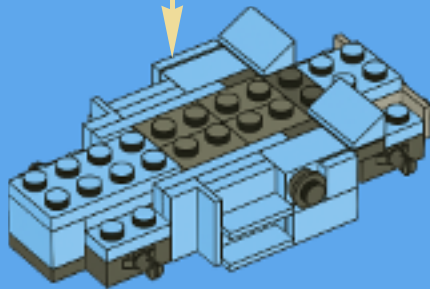
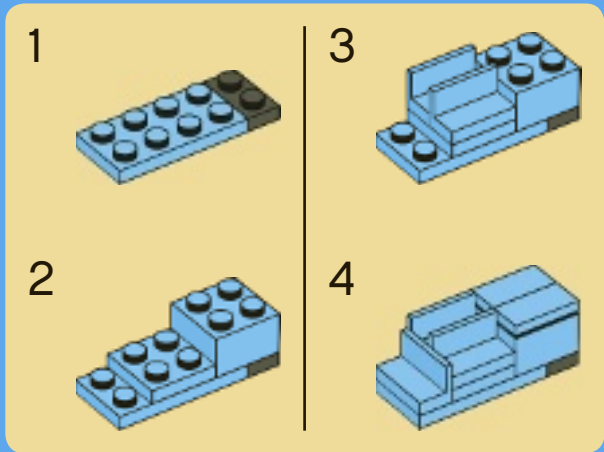

8

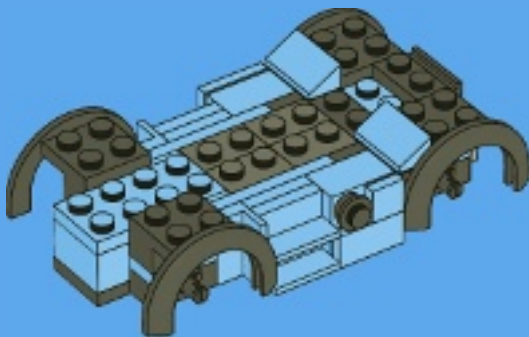







1



2

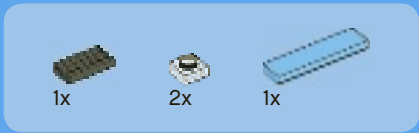
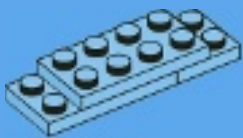

3

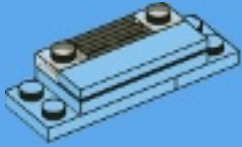

4

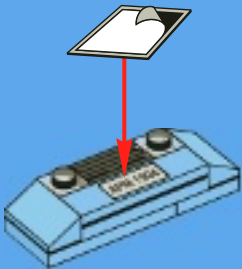



4x



2x



2x

# 5

1

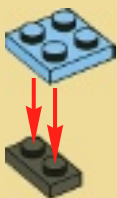

2



2x

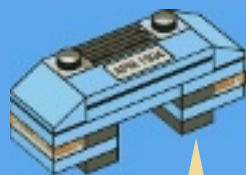

# 11

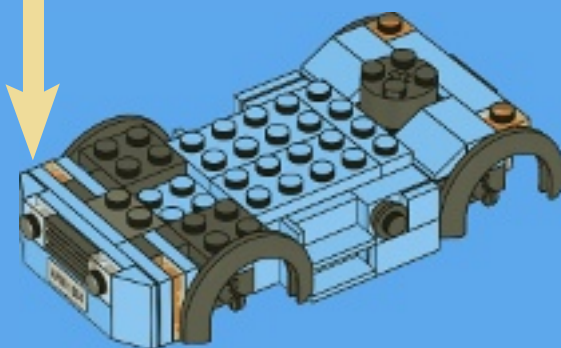

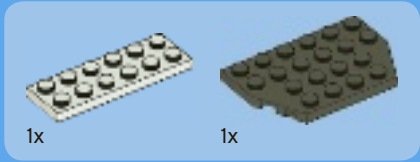
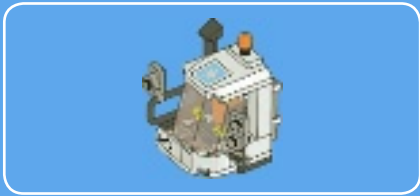

1

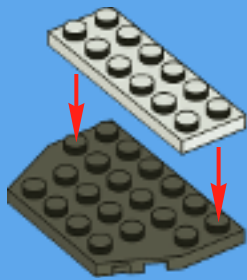

2



3

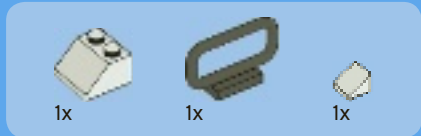
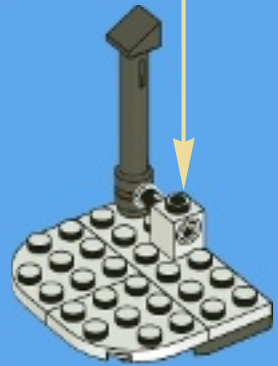
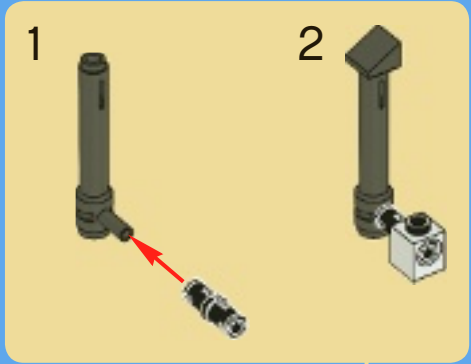

4

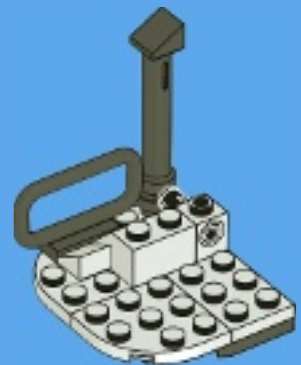



5

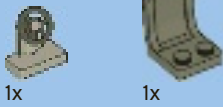
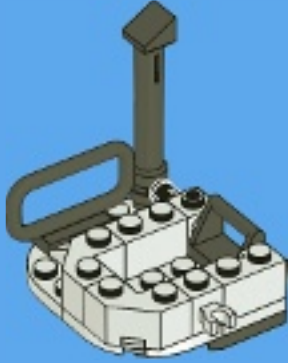

6

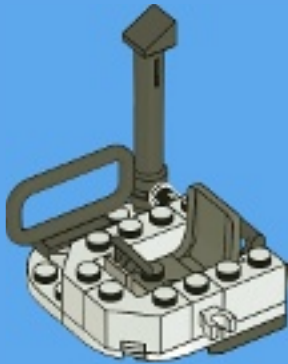

7

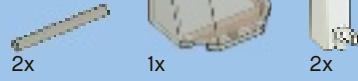

8

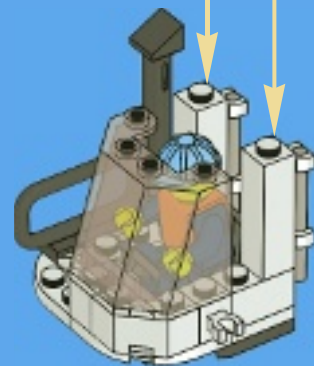
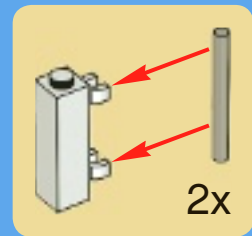



9

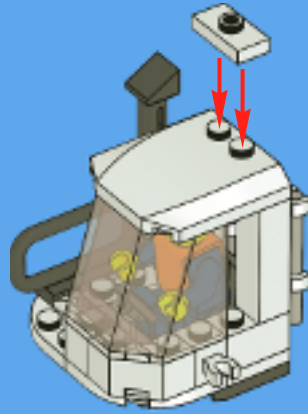

10

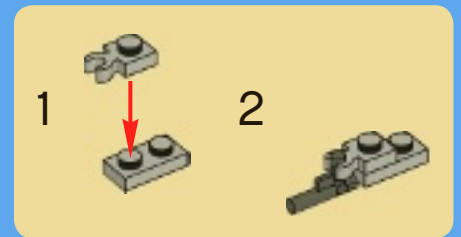
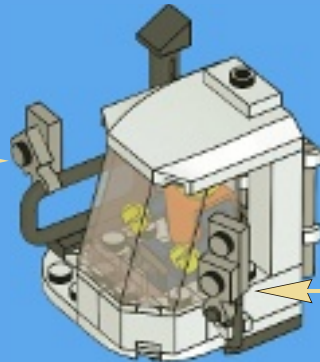
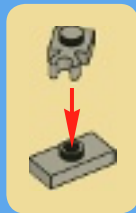

11

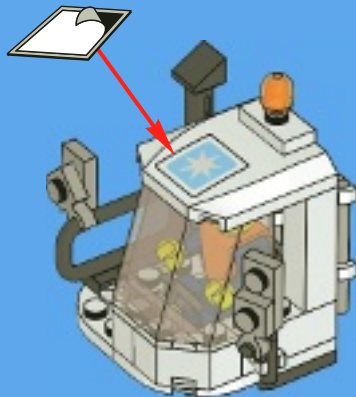

# 12

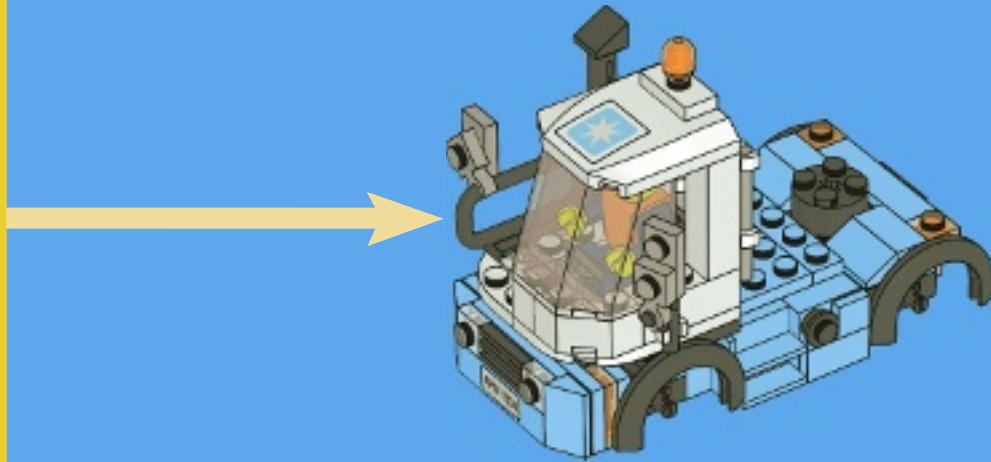

4x



4x

# 13



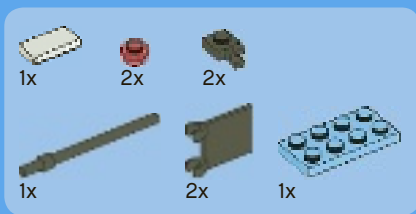

# 14

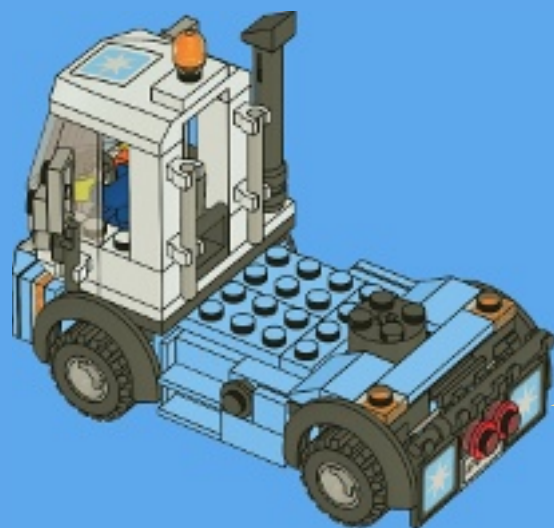

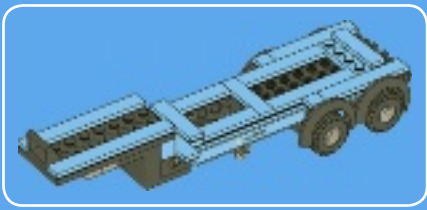

1

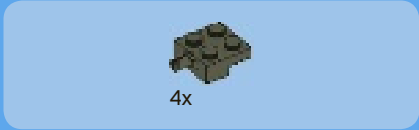
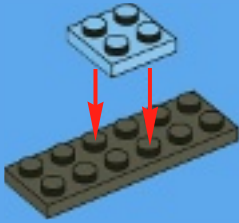

2



3

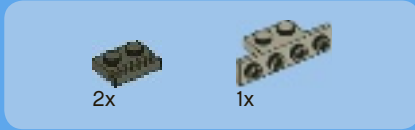

4

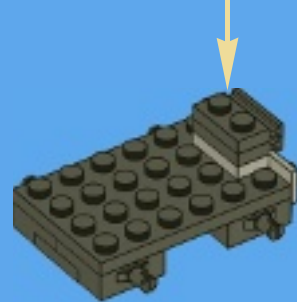
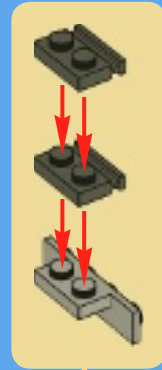





5

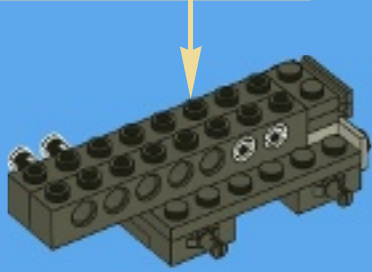
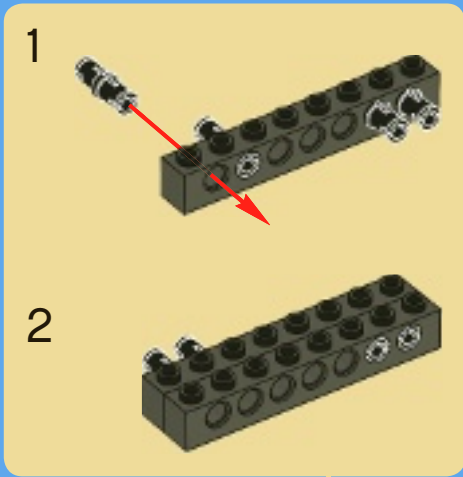

6

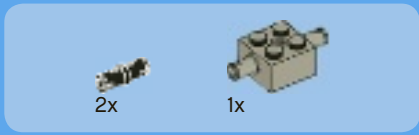

7



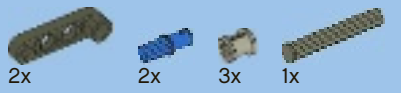

# 8

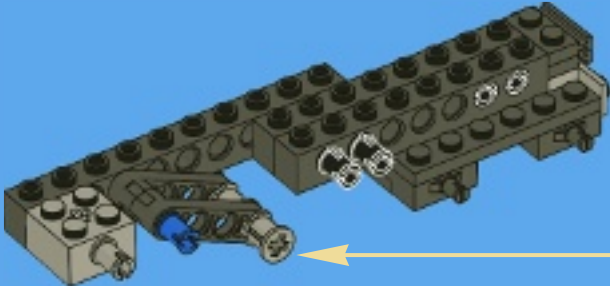

# 9





4x

# 10

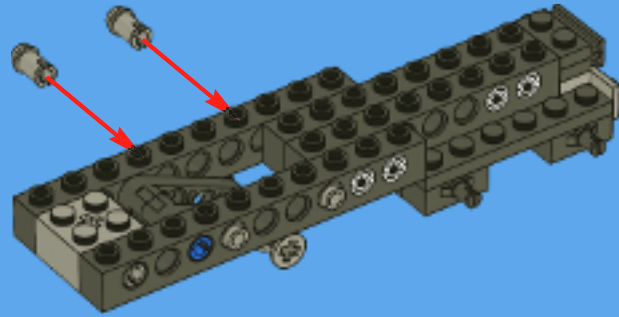

4x



2x

# 11

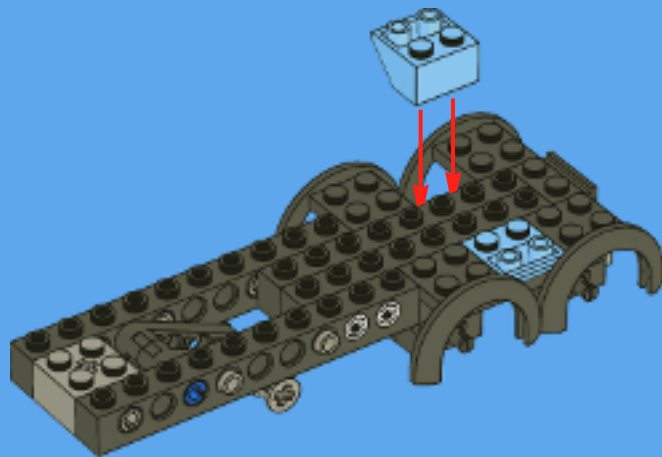

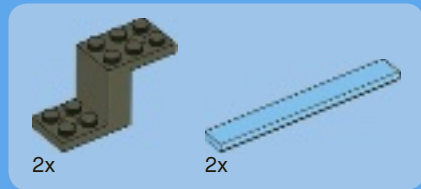

12

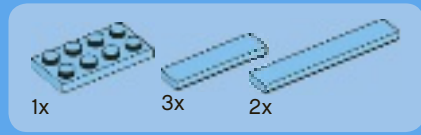
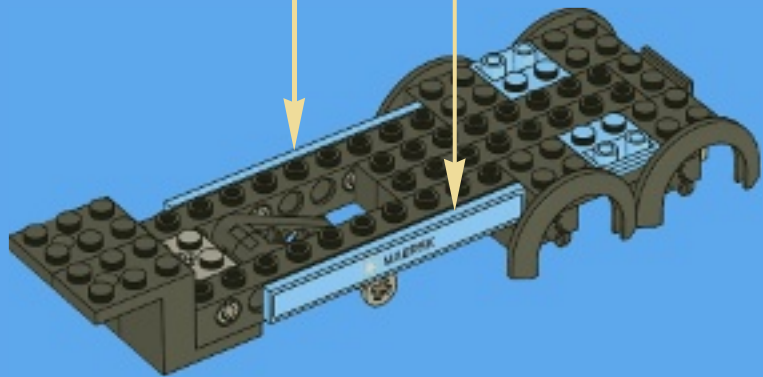
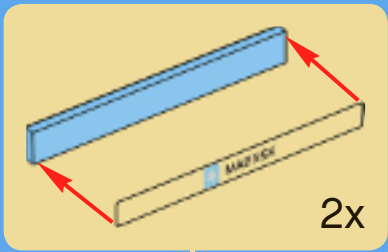

13

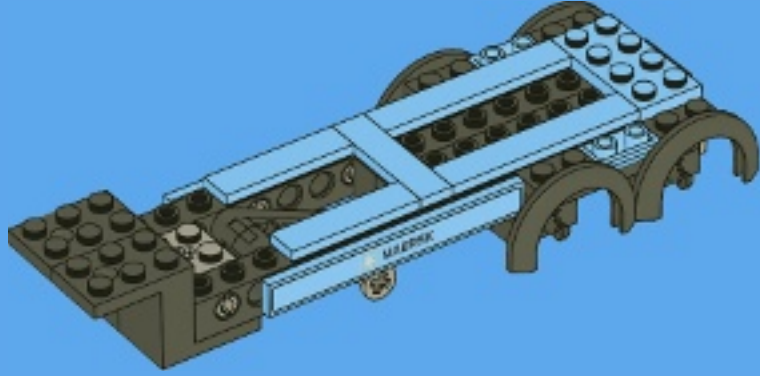

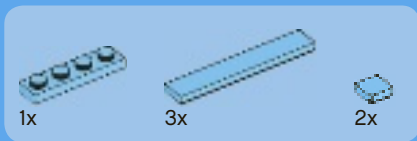

14

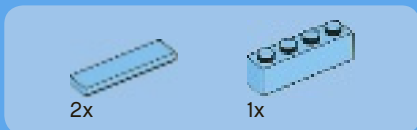
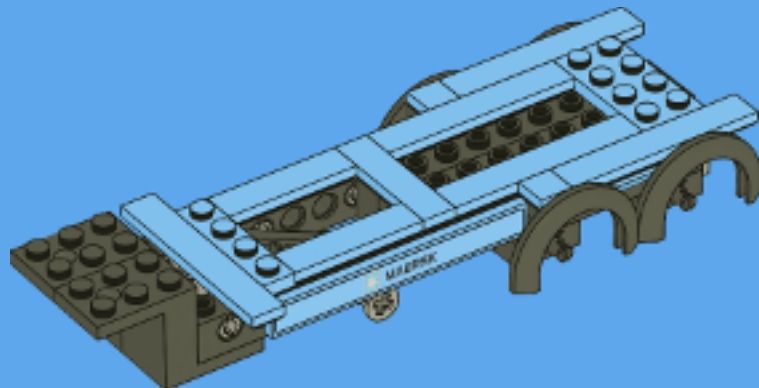

15

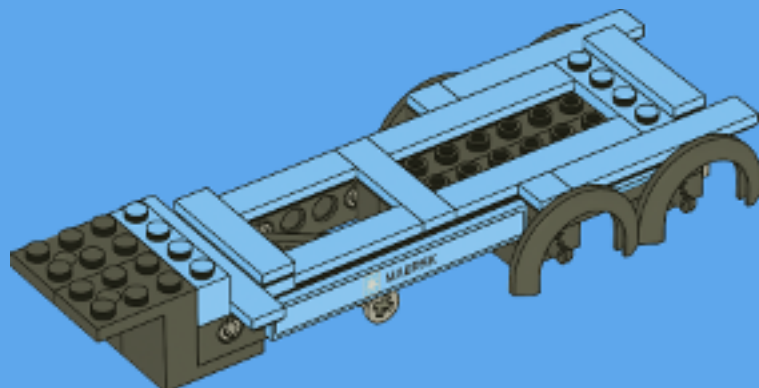



16

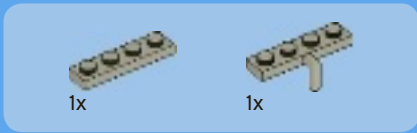
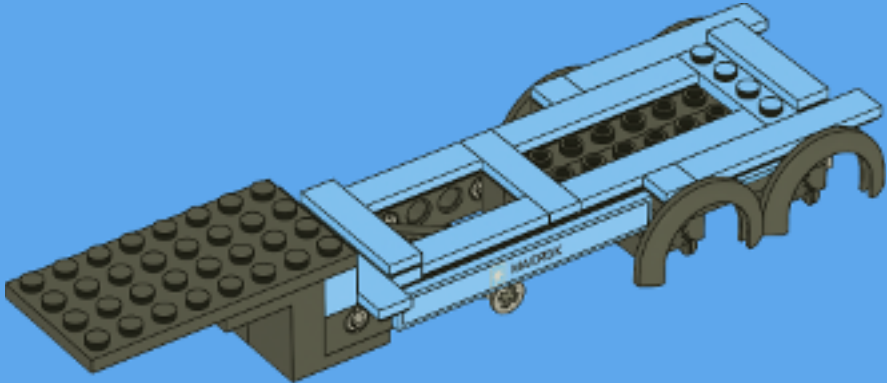

17

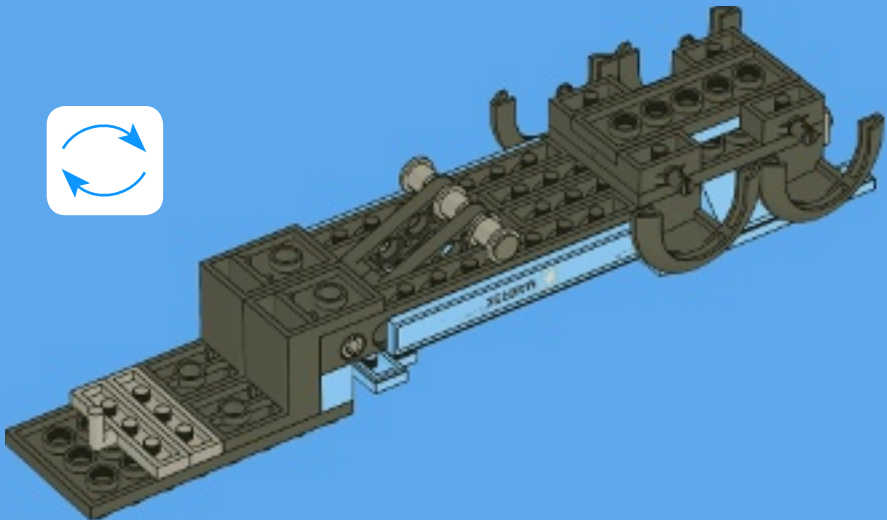



4x



4x

# 18

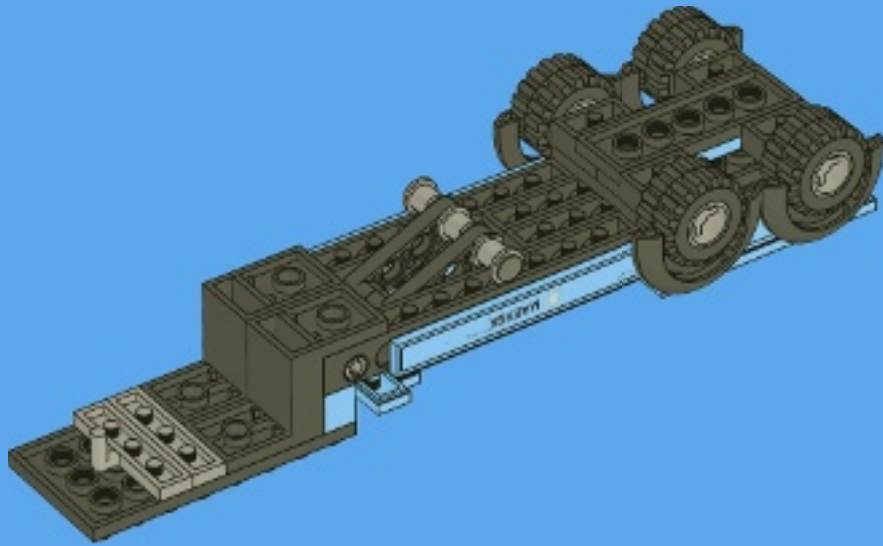

1x



2x



2x



1x



2x



1x

# 19

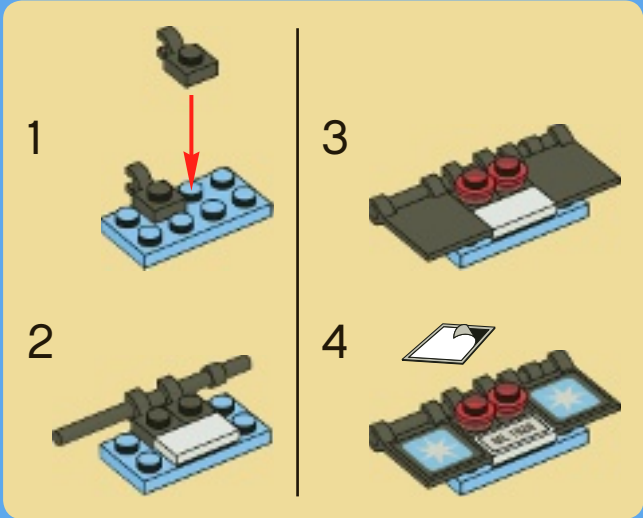
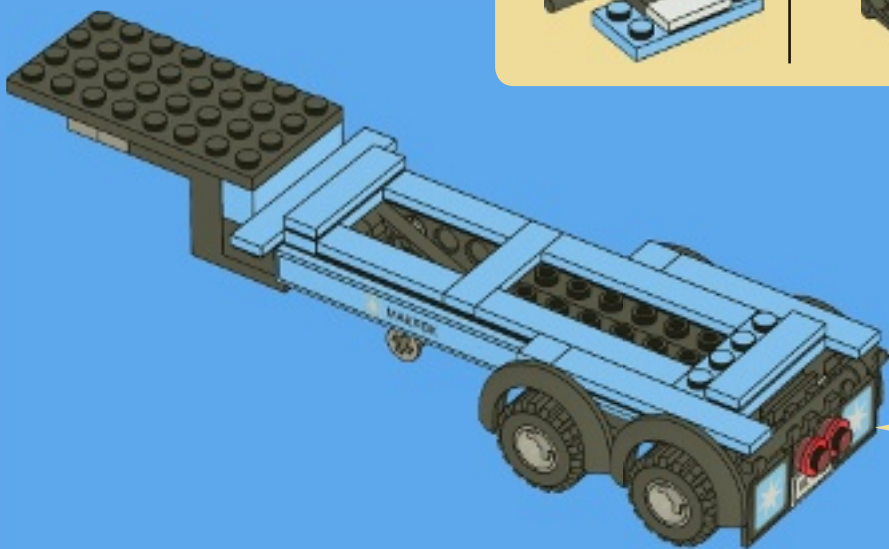



1x



2x



1:1

20

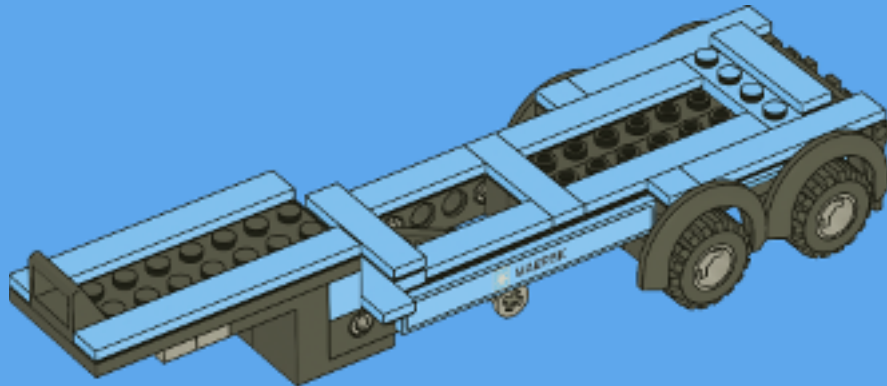

15

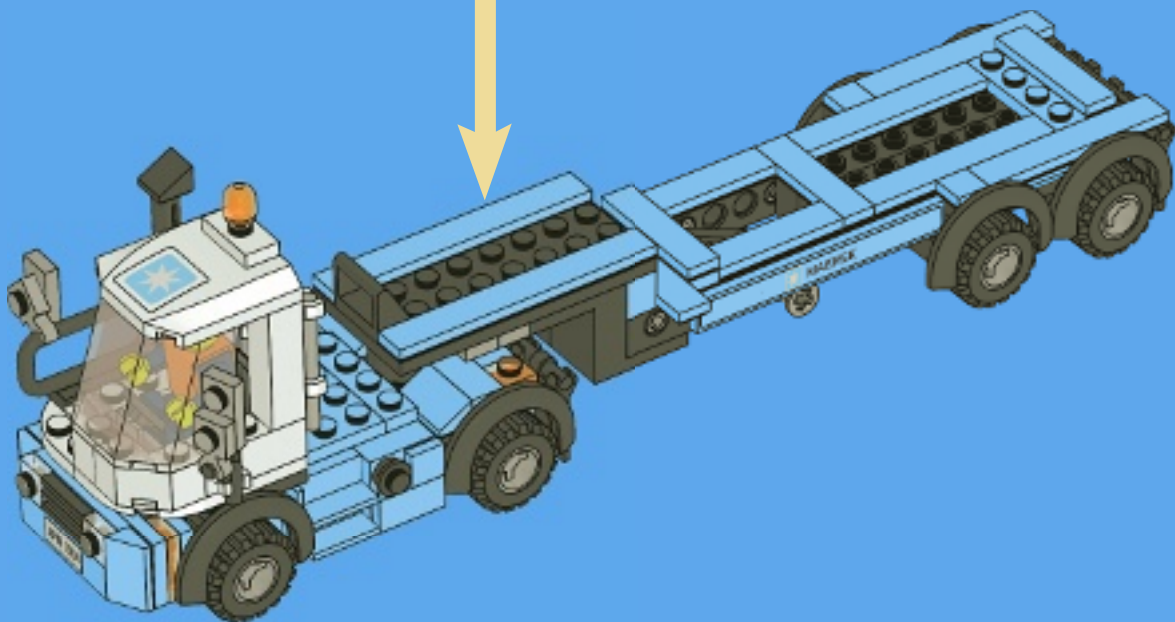



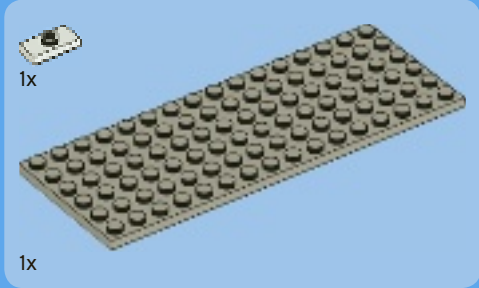

1

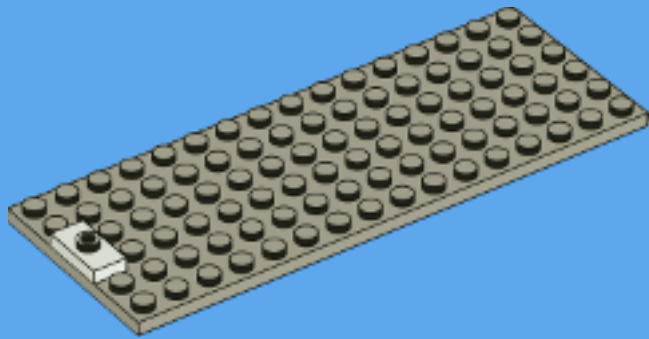

2

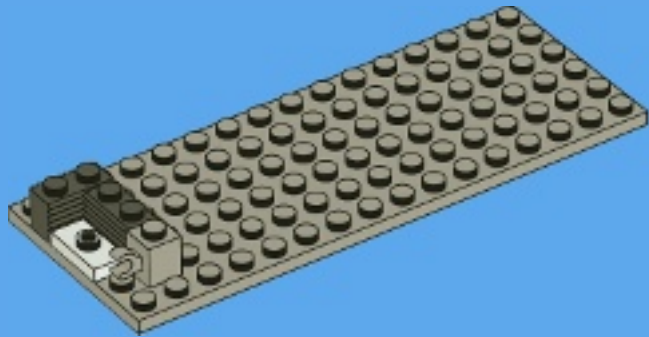



12x

3

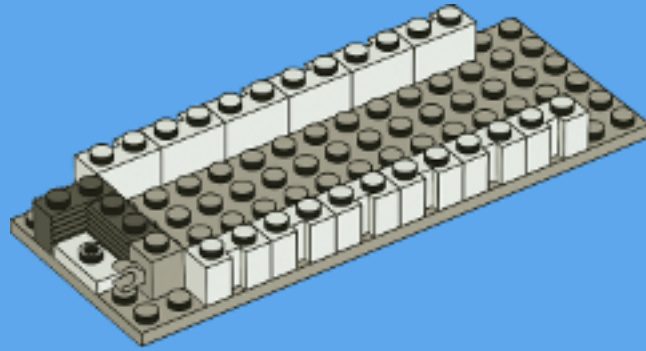

1x



1x



1x



1x

4

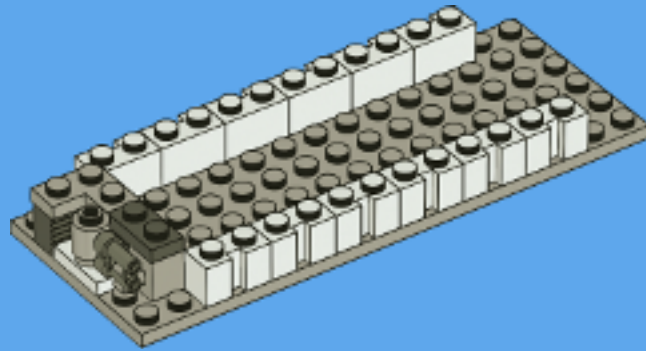

1x



1x

5

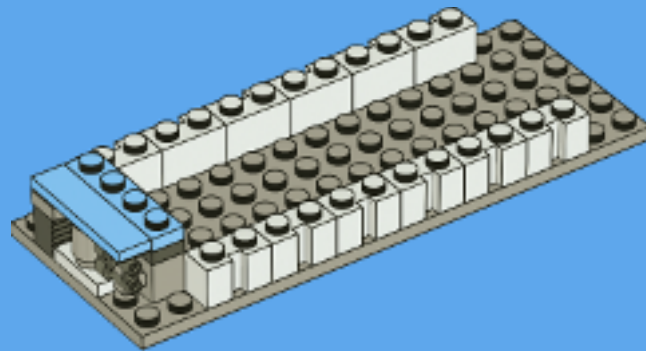

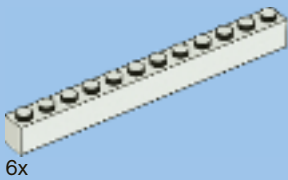

6x

# 6

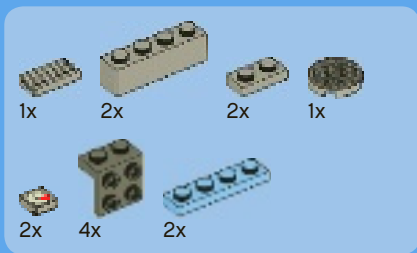
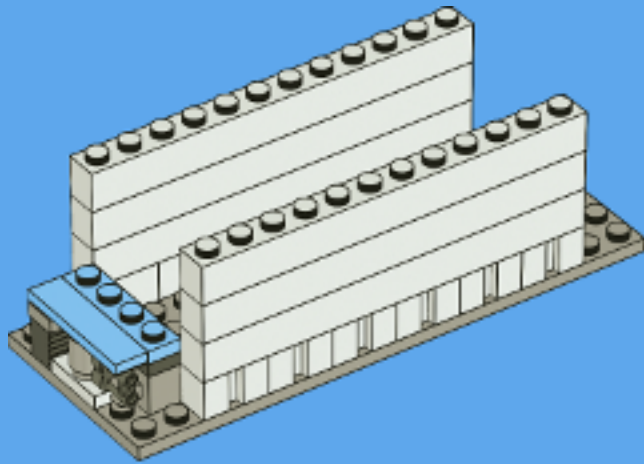

# 7

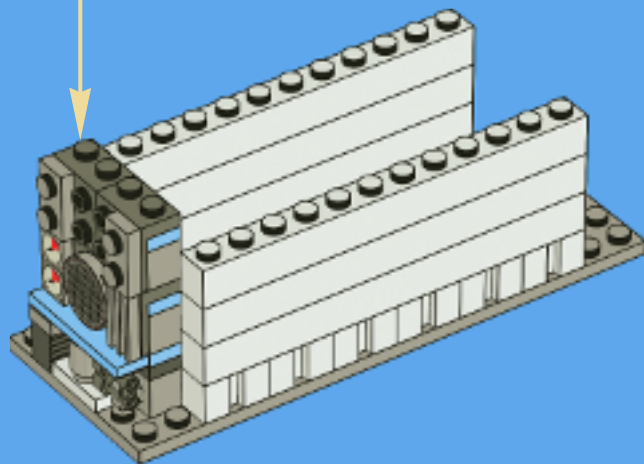
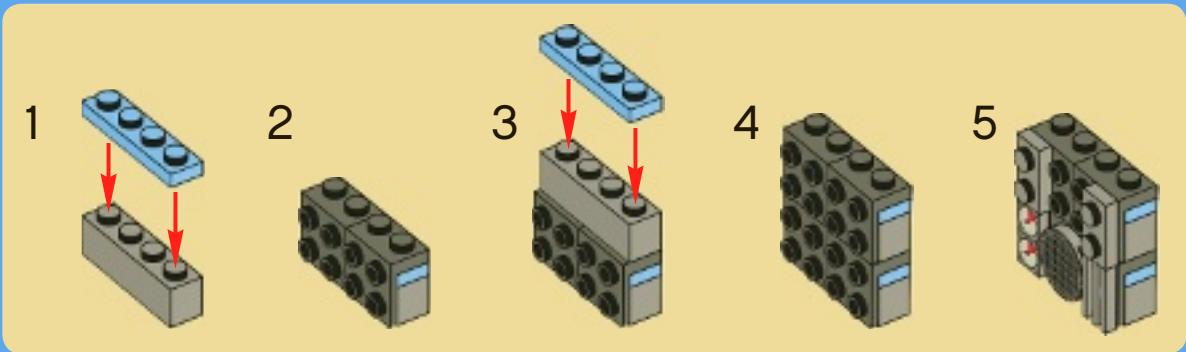

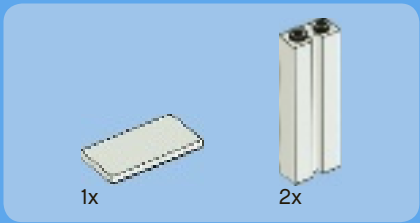

8

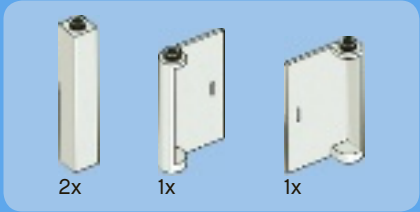
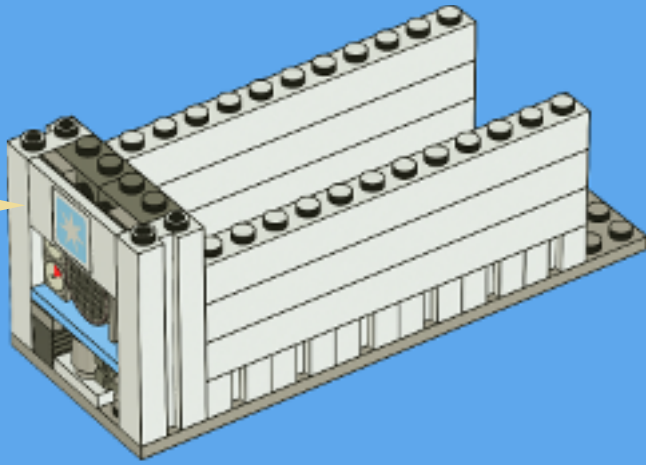
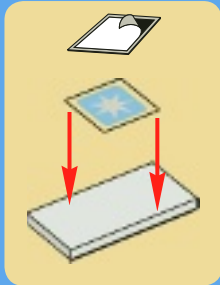

9

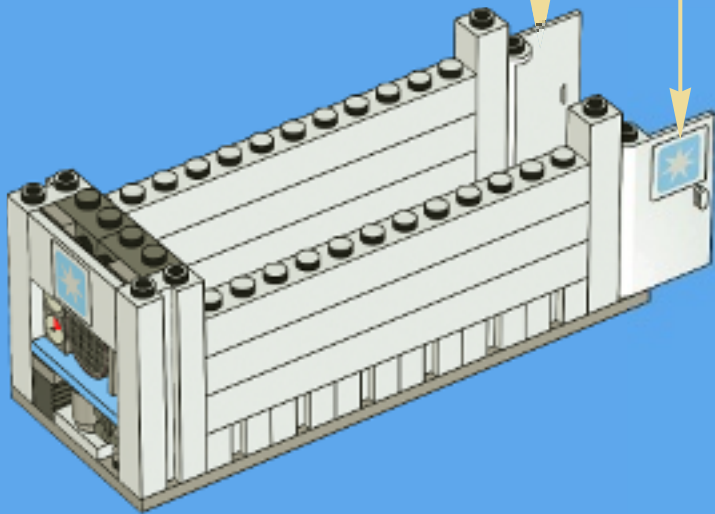
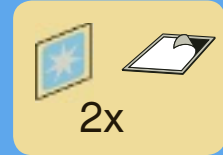



1x



12x

# 10

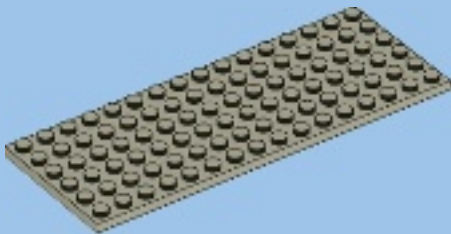
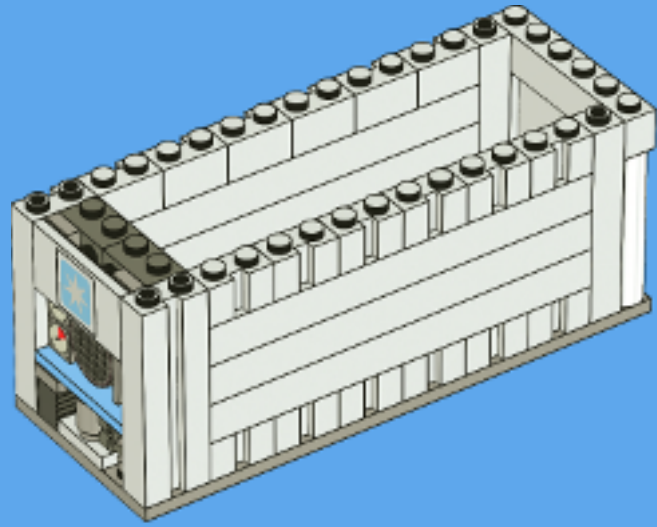

1x

# 11

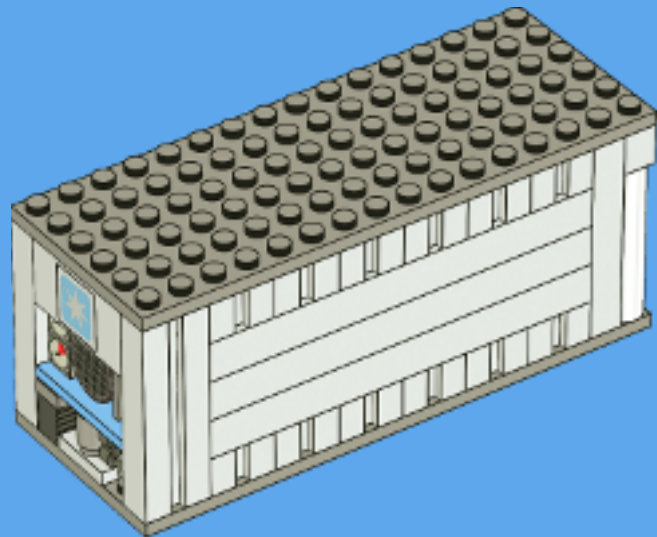



4x

12

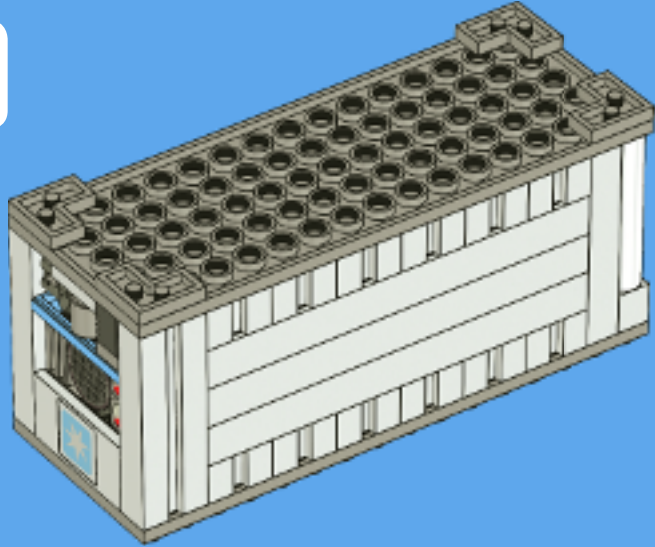

4x

13

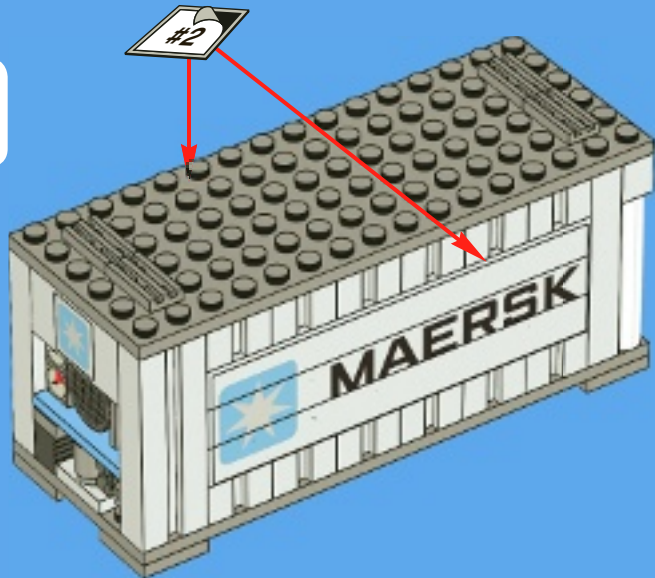

16









4x  
4581556

1x  
4616992

16x  
4496343

8x  
4621116

2x  
4589489

4x  
4589495

8x  
287826

4x  
4493326

8x  
4260488

2x  
4143372

1x  
4569407

4x  
4109810

7x  
4121715

6x  
4526982

4x  
370626

2x  
3000840

8x  
3005740

6x  
4552035

4x  
3005741

3x  
4210280

1x  
4543458

8x  
4298979

3x  
4162916

3x  
4625068

2x  
4542673

2x  
4280341

1x  
4524365

4x  
4211190

4x  
4216581

2x  
4507833

4x  
4211362

3x  
4211389

2x  
4211428

4x  
4211394

5x  
4211393

1x  
4211795

1x  
4535764

89x  
4617170

5x  
4211752

5x  
4211412

12x  
4521921

3x  
4211519

2x  
4255629

3x  
4211398

13x  
4211353

12x  
4211397

5x  
4211429

6x  
4211445

6x  
4560183

10x  
4211438

1x  
4243797

8x  
4211498

2x  
4616995

6x  
4211733

2x  
4211836

12x  
4211522

2x  
4211838

2x  
4211369

2x  
4594238

17x  
4211350

3x  
4211451

4x  
4277927

4x  
4211568

13x  
4211472

2x  
4282740

1x  
4261605

4x  
4211748

8x  
4211807

8x  
4211483

4x  
4211475

1x  
4221881

2x  
4585429

3x  
4617152

2x  
4617168

2x  
4617109

2x  
4211628

8x  
4211764

3x  
4211701

1x  
4226995

4x  
4211573

3x  
4211622

1x  
4211758

26x  
4277928

1x  
4603504

1x  
4217558

4x  
4210967

2x  
4524930

1x  
4211051

4x  
4210469

2x  
4560177

12x  
4558955

1x  
4211046

1x  
4215740

4x  
4210998

8x  
4210763

**Customer Service**  
Kundenservice  
Service Consommateurs  
Servicio Al Consumidor

[www.lego.com/service](http://www.lego.com/service) or dial



: 00800 5346 5555

: 1-800-422-5346



10219



8878 + 8887 +  
8884 + 8879 + 88002

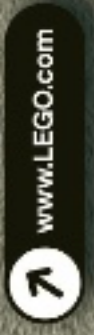
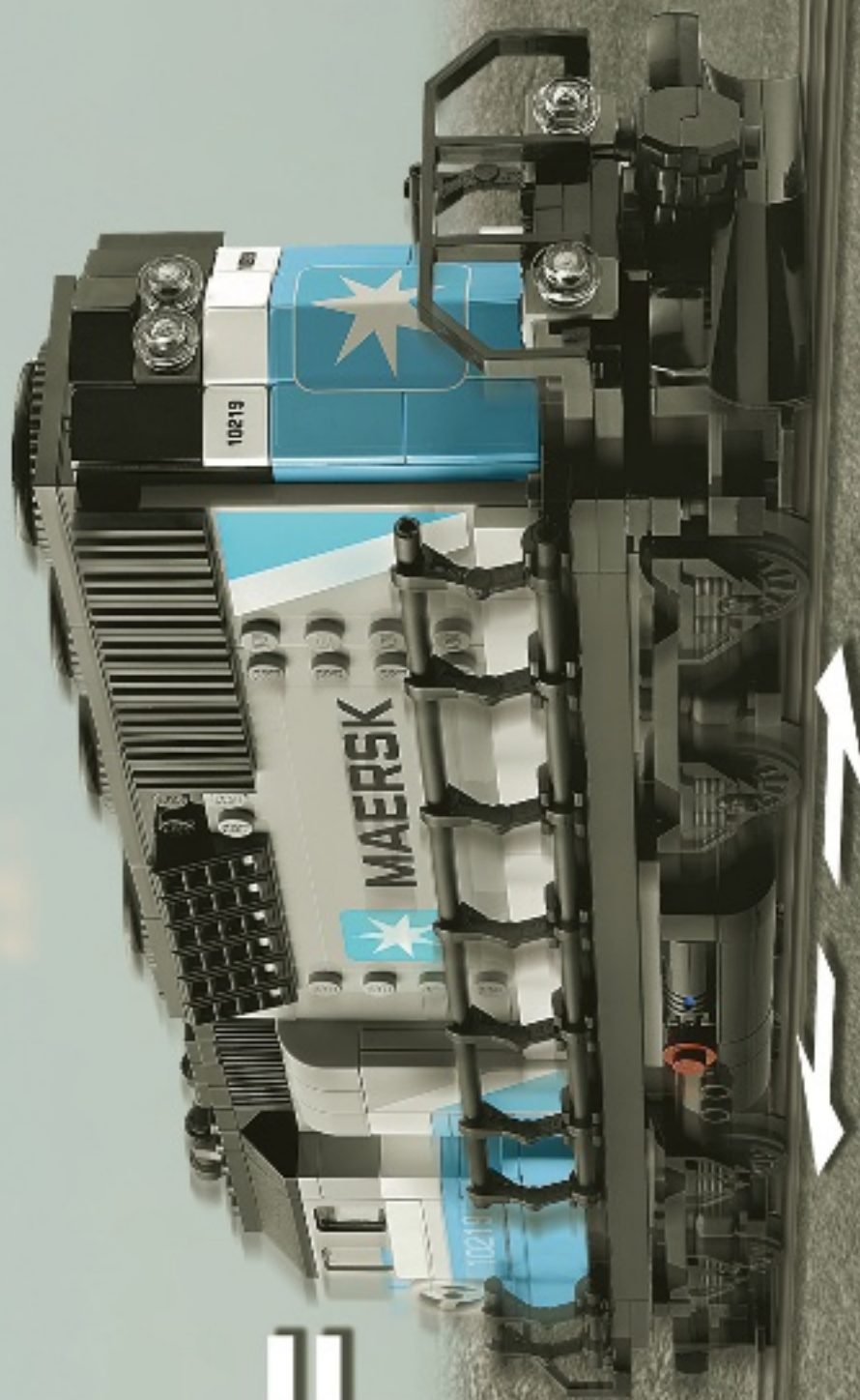

1

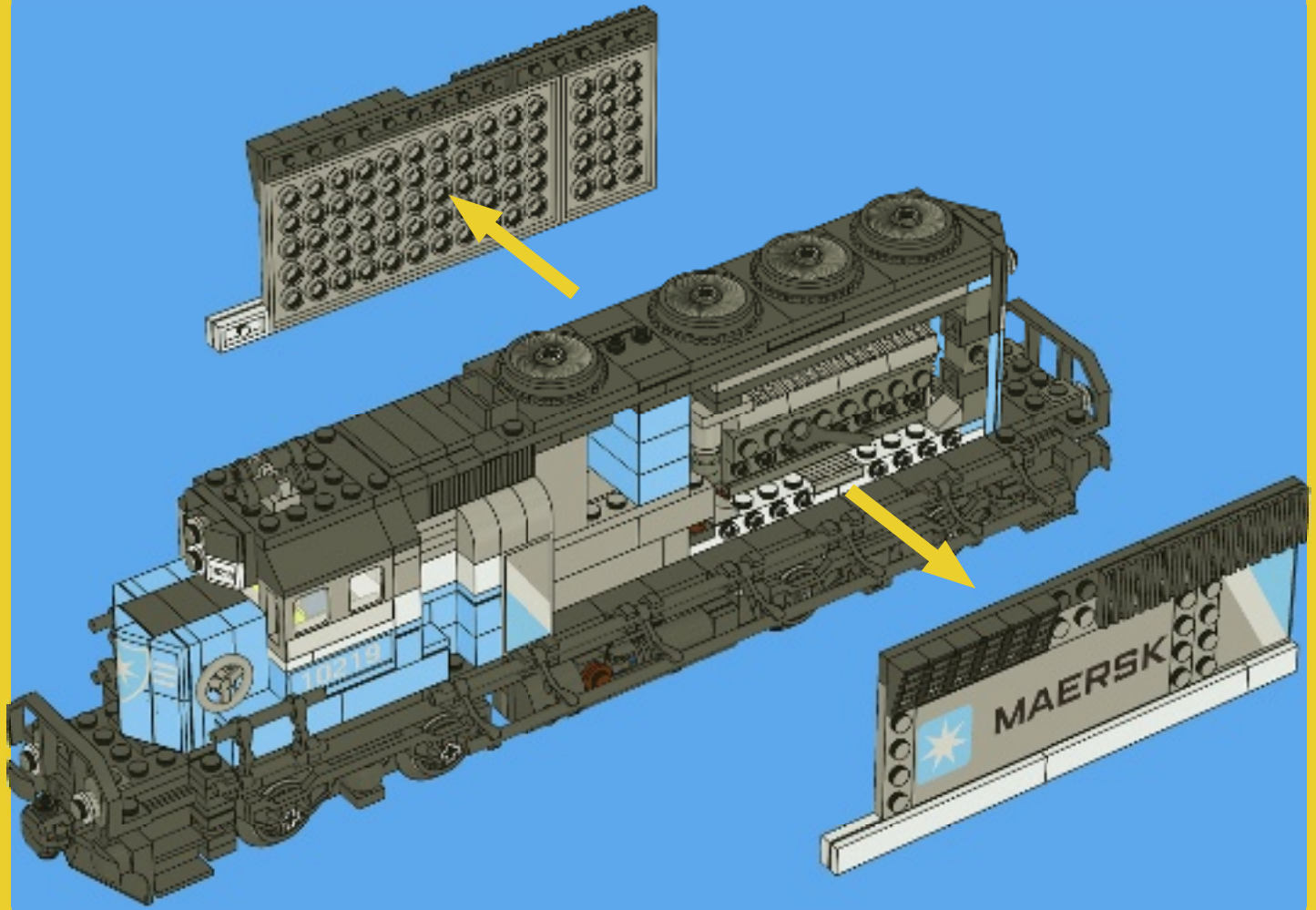

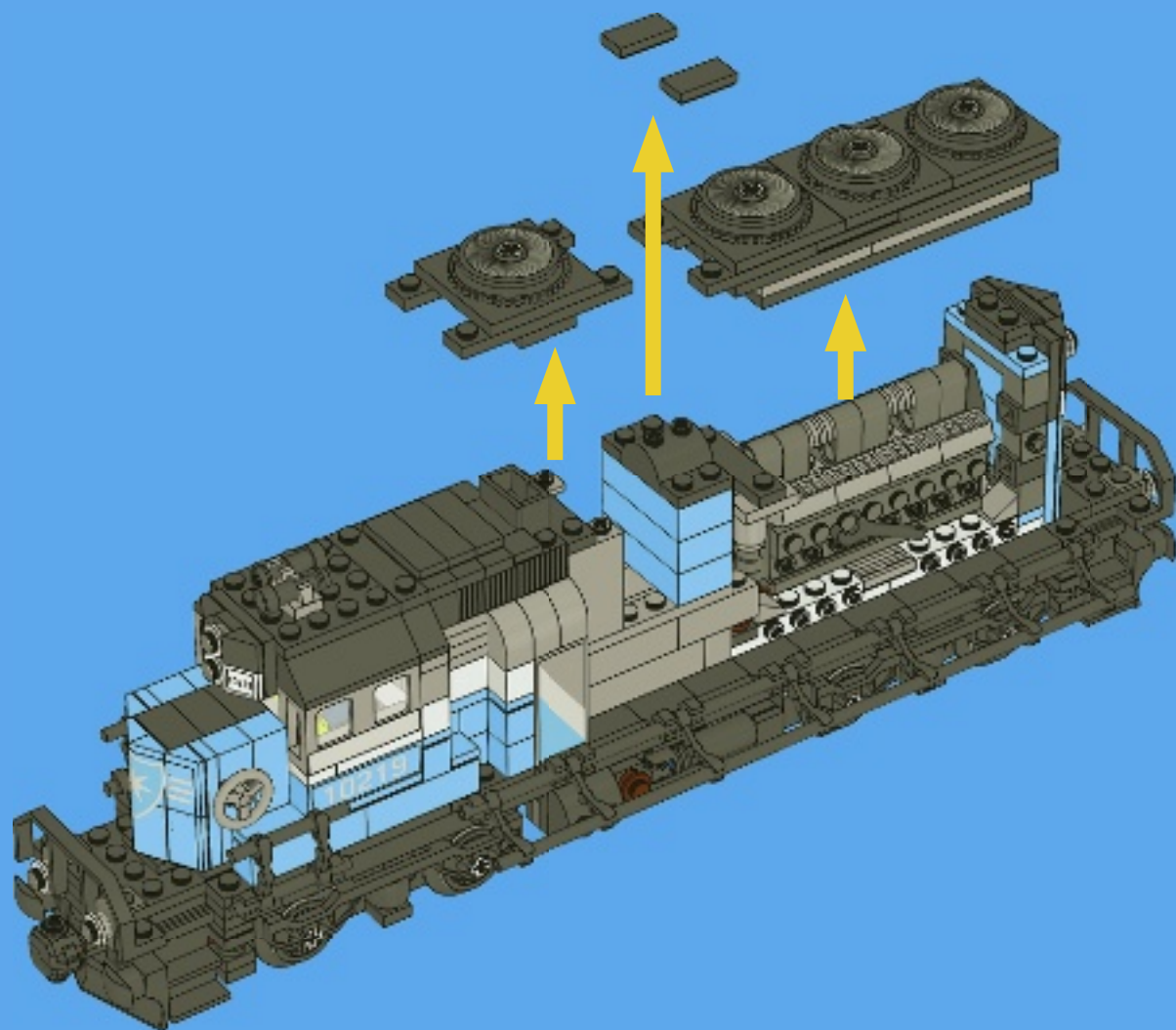

3

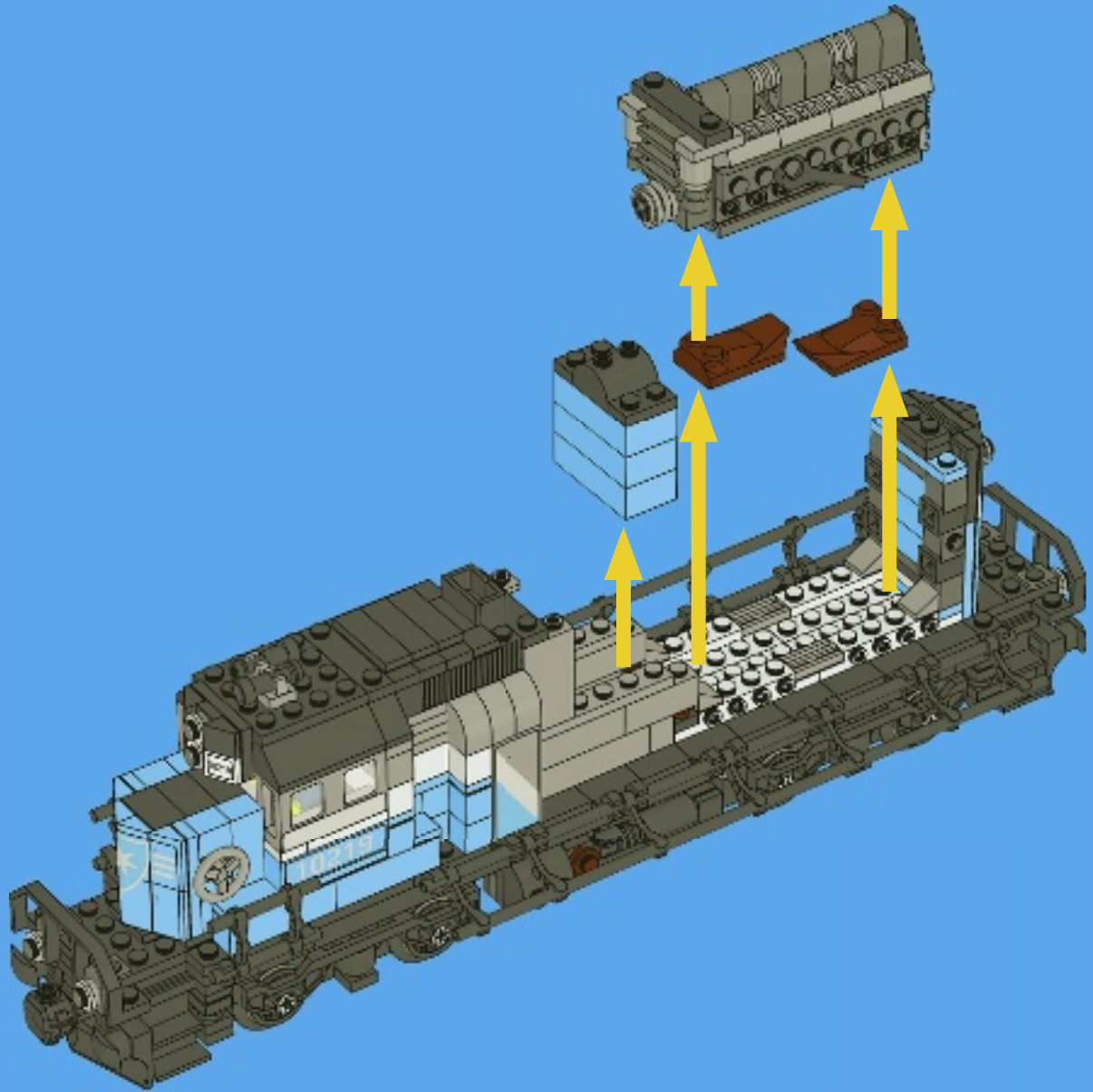

4

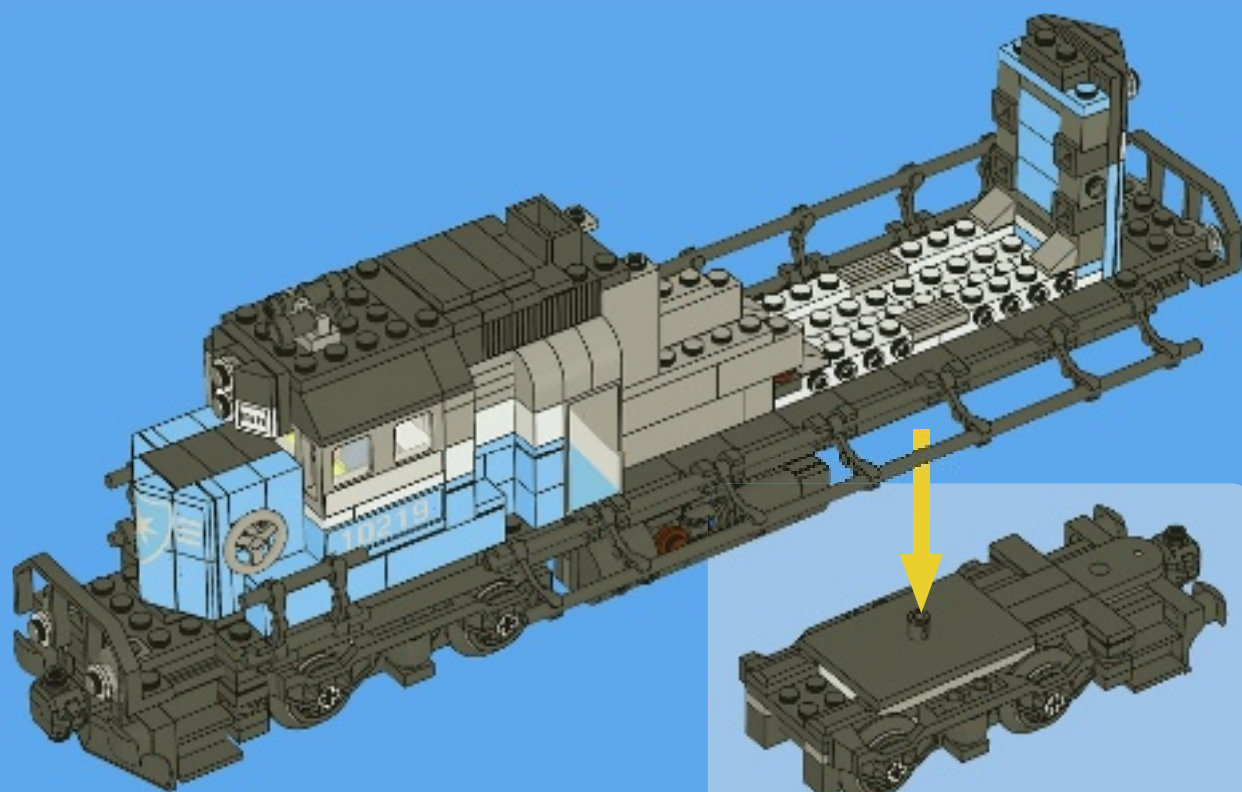

5

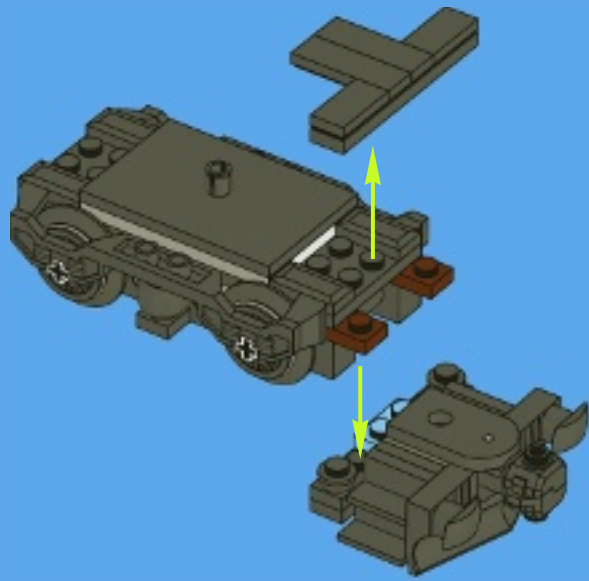

6

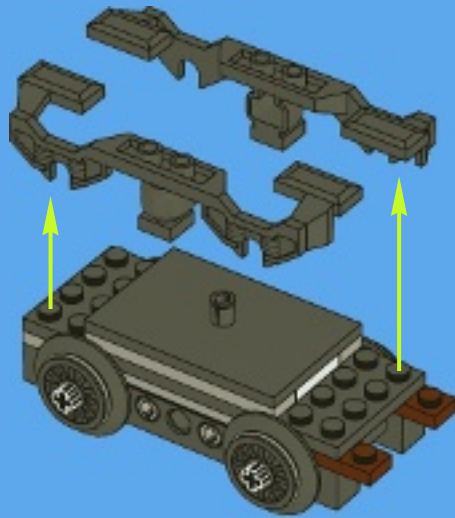

7

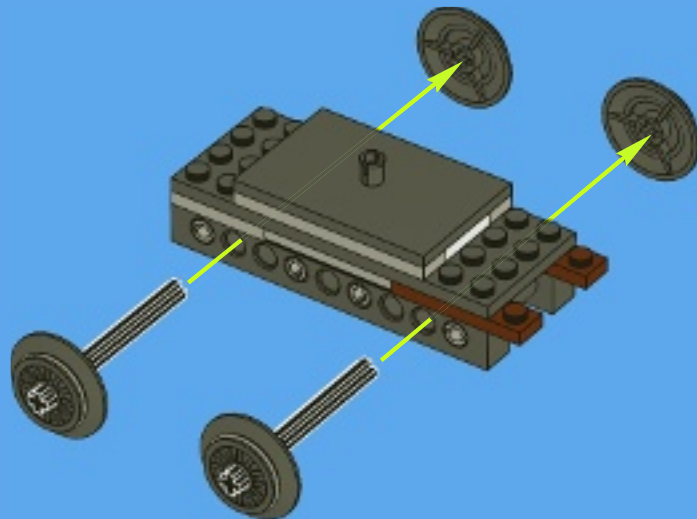



8

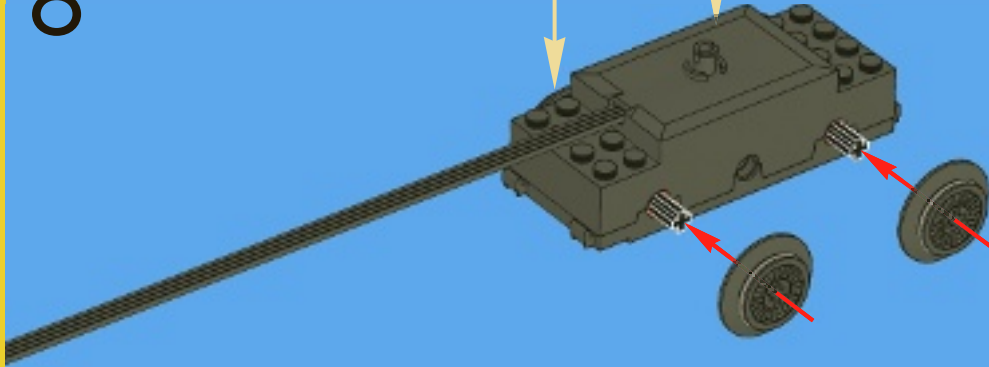

9

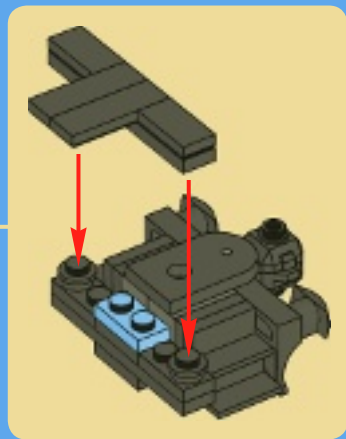
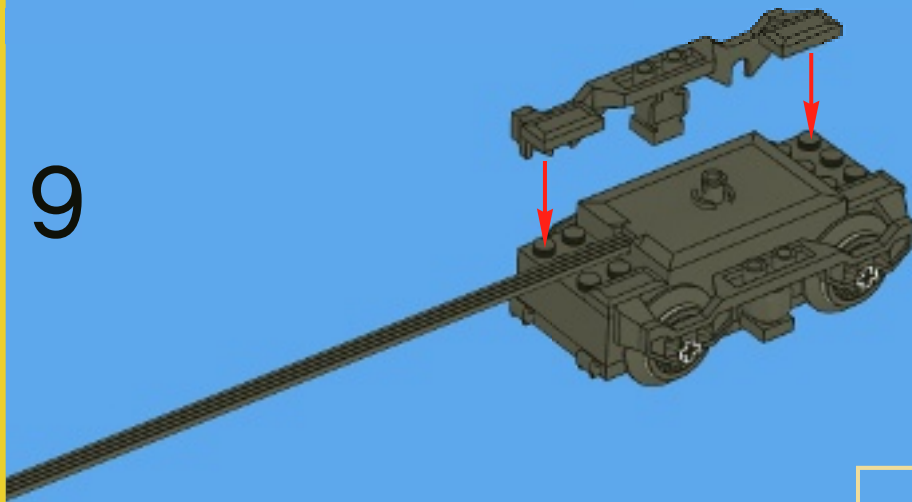

10

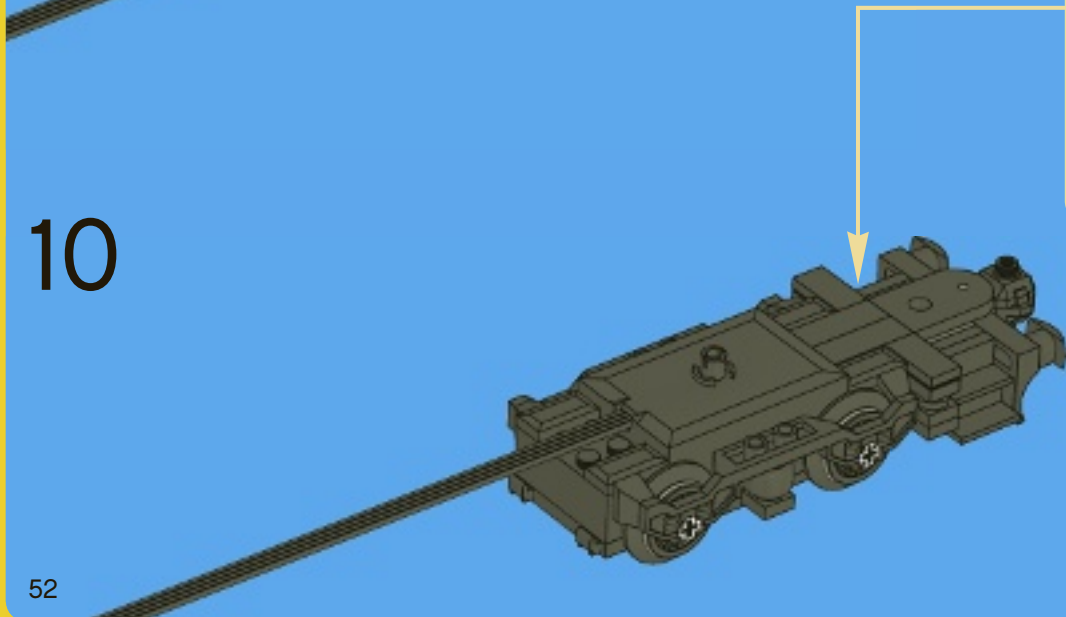



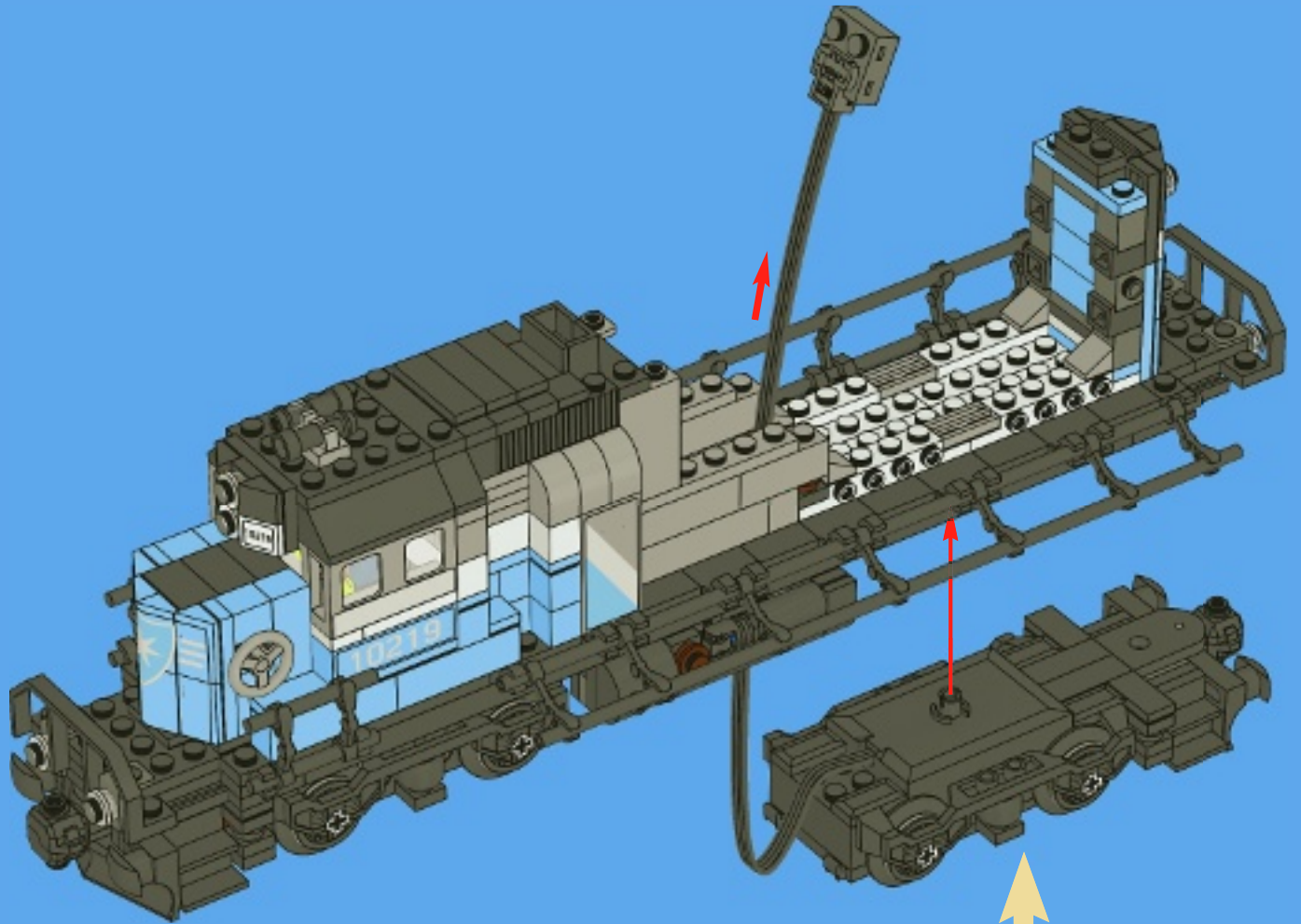

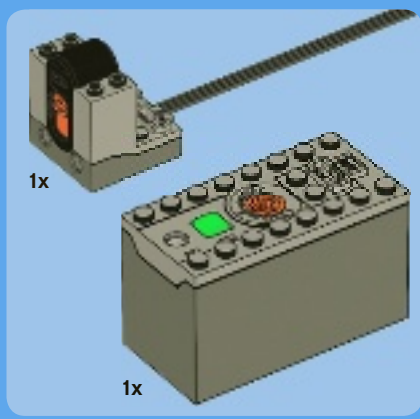

12

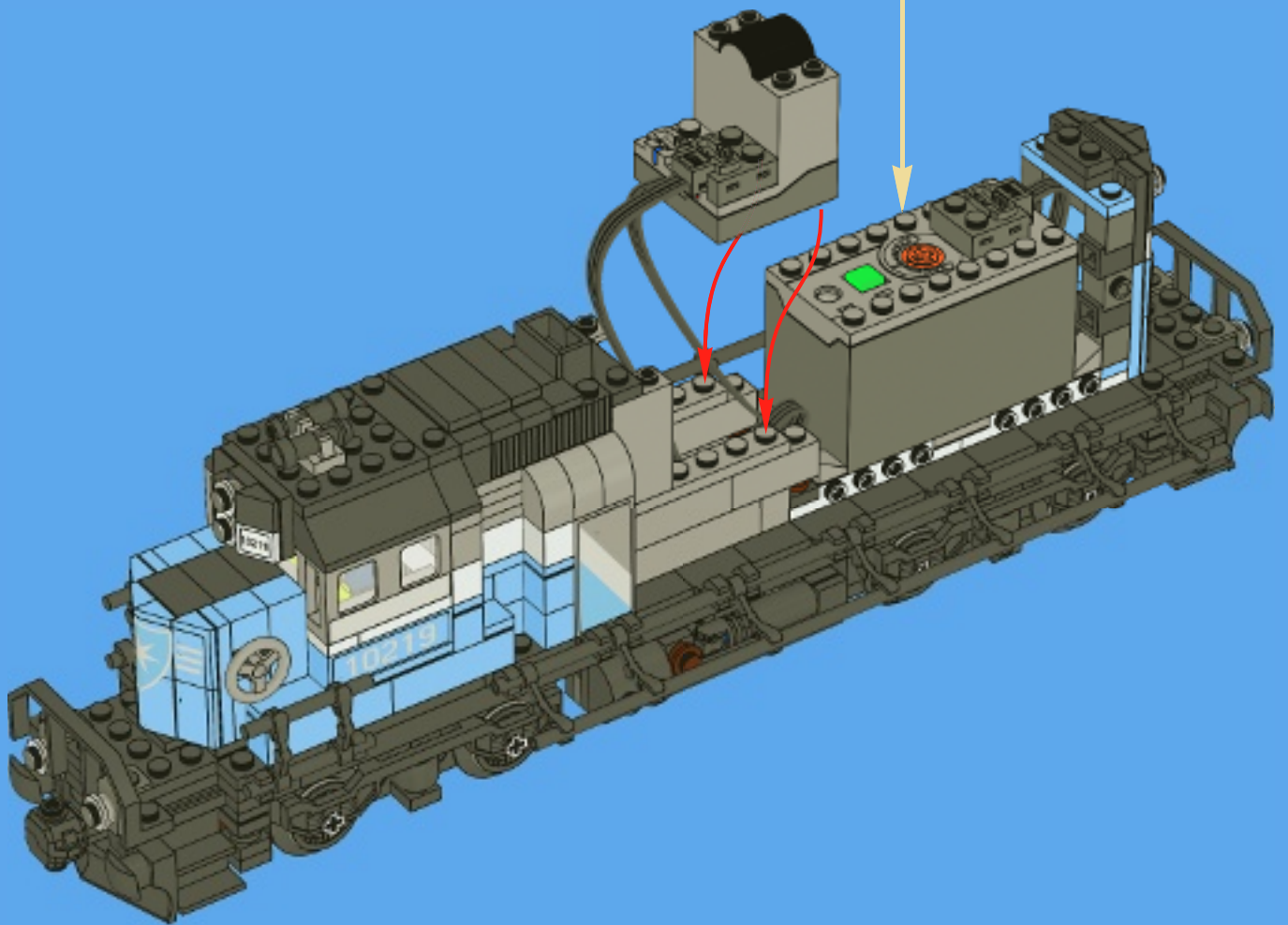
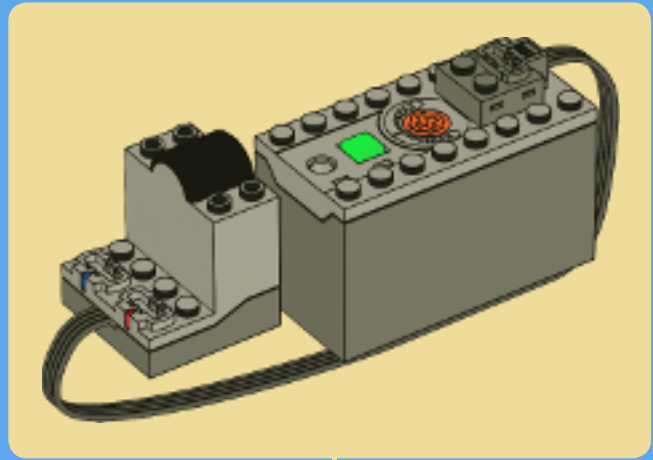

13

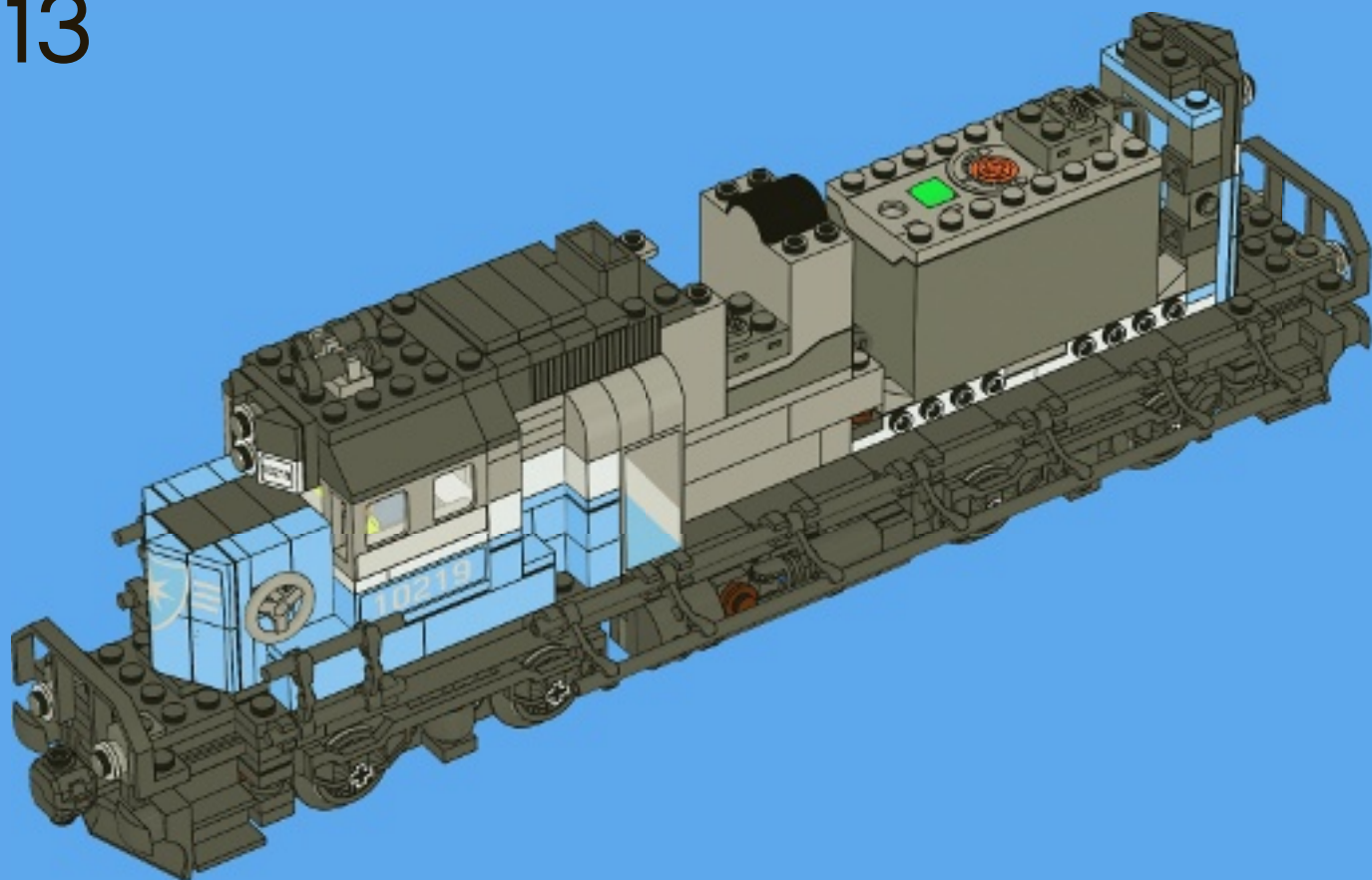

14

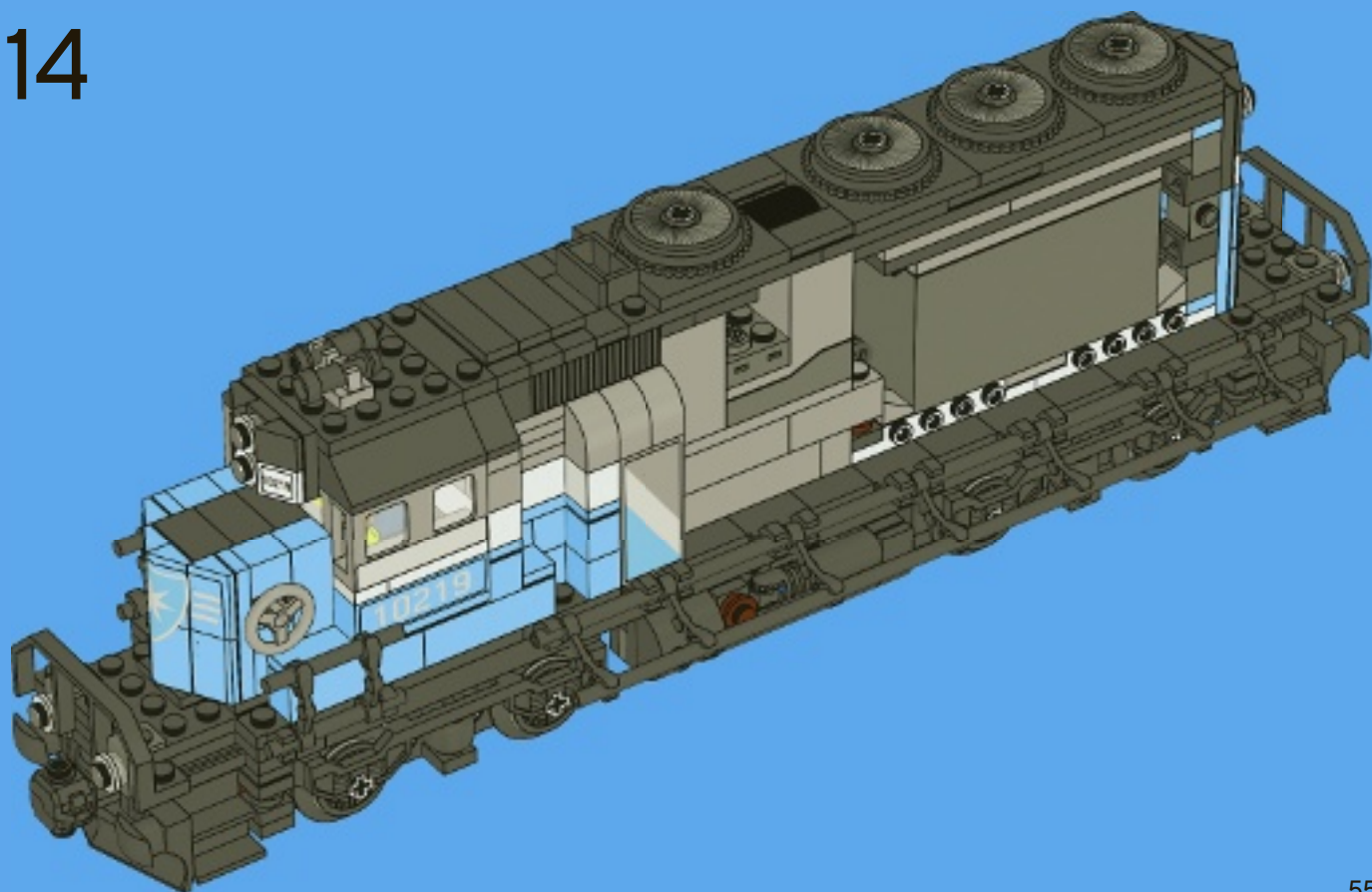

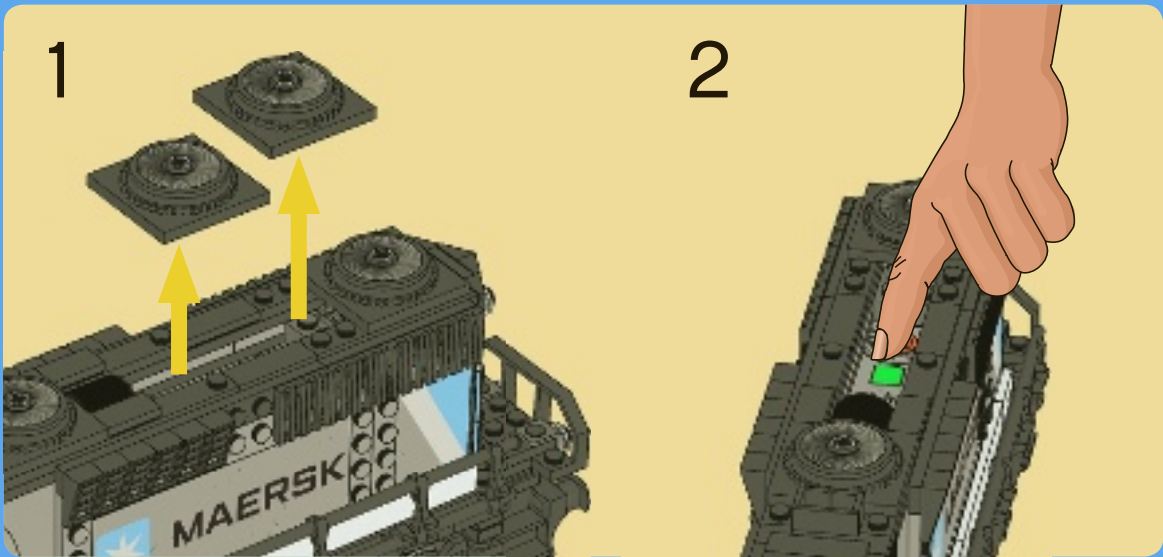
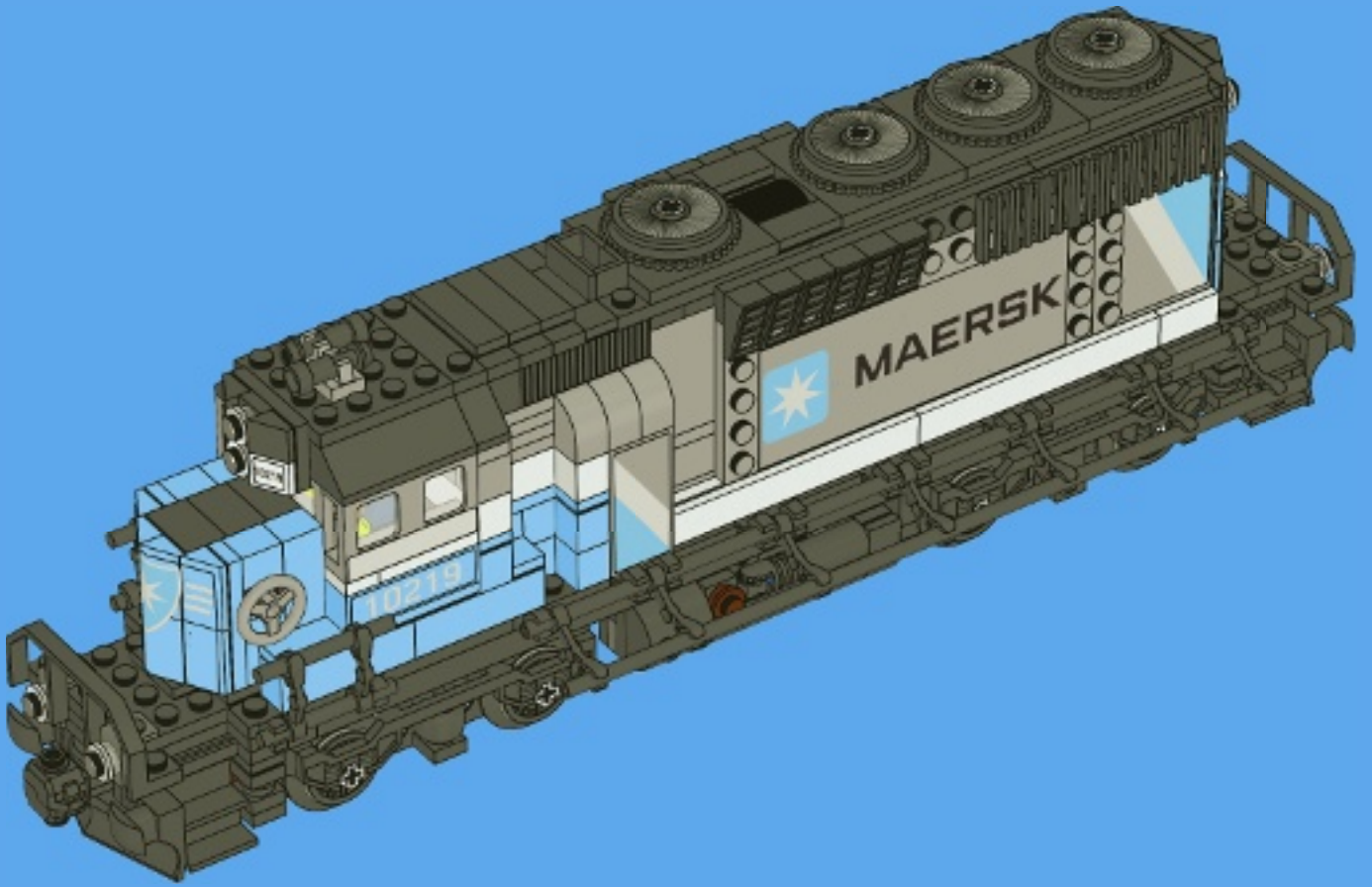

10194





10213





# club

## FREE! GRATIS! GRATUIT!



www.LEGOclub.com



LEGO Club Magazine



LEGO Club Email

VISIT THE WORLD'S BIGGEST LEGO SHOP!

www.LEGOshop.com

GO TO

www.LEGOclub.com

00800 5346 5555



1-866-534-6258 • 1-877-518-5346

US & Canada only

Canada seulement



\* Freephone. Mobile charges may apply. \* Numéro sans frais. Des frais peuvent s'appliquer avec les téléphones cellulaires. \* Gebührenfrei. Kosten für Anrufe aus Mobilfunknetzen können abweichen. \* Gratis telefonnummer vanaf vaste lijn. \* Det er et gratis nummer, når du ringer fra fasttelefon. \* Det är gratis, när du ringer från en fast telefon. \* Numéro sans frais. Des frais peuvent s'appliquer avec les téléphones portables.

**YES!** I want to join the LEGO Club FREE! **OUI!** Je veux m'abonner au LEGO Club GRATUITEMENT! **Ja!** Ich möchte Mitglied im kostenlosen LEGO Club werden. **Ja!** Ik wil graag GRATIS lid worden van de LEGO Club. **Ja!** Jeg ønsker å melde meg inn i LEGO Club gratis! **Ja!** Jag vill gå med i LEGO Club GRATIS!

First name • Prénom  
Vorname • Voornaam  
Fornavn • Förnamn

Last name • Nom de famille  
Name • Achternaam  
Etternavn • Efternamn

Date of Birth • Date de naissance  
Geburtsdag • Geboortedatum  
Fødselsdato • Fødselsdatum

Boy • Garçon • Junge • Jøngem • Gut • Pojk  
Girl • Fille • Mädchen • Meisje  
Jente • Flicka

Street • Adresse  
Straße, Hausnr.  
Straat, huisnr. • Adress

City • Ville  
Ort • Woonplaats  
Poststed • Postort

Zip/Postcode  
Code Postal • PLZ  
Postcode  
Postnummer

Country  
Pays  
Land

Email • Courriel  
E-Mail • E-post

Mail to: /  
Poster à:

LEGO Club  
P.O. Box 1157  
Enfield, CT USA  
06083-1157

Send til:  
LEGO Club Norge  
Postboks 58  
1314 Vøyenenga

Mail to:  
LEGO Club  
33 Bath Road  
Slough SL1 3UF  
United Kingdom

Skickas till:  
LEGO Club Sverige  
Ubox 841  
202 29 Malmö

Per Post an:  
LEGO Club  
Postfach 14 15  
D-36243 Niederaula

Poster à:  
LEGO Club  
21 rue de la banque  
75 002 PARIS  
FRANCE

Stuur op naar:  
LEGO Club  
Postbus 40250  
3504 AB Utrecht

- Fill in your email address and we will send you a membership confirmation and monthly email newsletters. If you do not wish to receive the newsletters please tick here. Remplis ton adresse e-mail et nous t'enversons une confirmation d'adhésion ainsi que le bulletin e-mail mensuel. Si tu ne désires pas recevoir le bulletin, coche cette case. Vül je e-mailadres in en we sturen je een bevestiging van je lidmaatschap en maandelijkse e-mail nieuwsbrieven. Als je geen e-mail wilt ontvangen, kruis dan dit vakje aan.
- If you do not wish to receive additional mailings from the LEGO Club please tick here. Si tu ne désires pas recevoir de courrier supplémentaire du Club LEGO, coche cette case. Als je geen verdere post van de LEGO Club wilt ontvangen, kruis dan dit vakje aan.
- Om du vill få annan information från LEGO Gruppen, sätt ett kryss här. Dersom du ønsker å motta annen informasjon fra LEGO Gruppen, setter du et kryss her.

**ENGLISH** The English language version of the magazine can only be mailed to addresses in the US, Canada, the UK and Republic of Ireland. Club membership is valid for two years and includes free copies of the LEGO Club Magazine and e-mail newsletters. In the US and Canada please allow up to 6 weeks for delivery of your first magazine. In the UK and Republic of Ireland please allow six to 14 weeks for delivery of your first magazine. By signing this form you consent the LEGO Club to use your child's data for LEGO mailings. The data will only be used for LEGO mailings and will not be sold, rented or otherwise disclosed to any company outside the LEGO Company except for disclosure to companies acting as our agents to help us provide services requested by the child. This coupon is valid for one free membership per person, group or organization. Photocopied coupons are accepted. **FR** La version française du magazine peut être postée uniquement au Canada. L'abonnement est valide pour 2 ans et inclut des exemplaires gratuits du Magazine LEGO. Aux E-U et au Canada, allouer 6 semaines pour la livraison initiale. En remplissant ce formulaire, vous consentez à ce que LEGO utilise les informations de votre enfant pour des envois postaux de LEGO. L'information sera utilisée uniquement pour des envois postaux par LEGO et ne sera en aucun cas, vendue, louée, échangée ou divulguée à d'autres compagnies autres que la compagnie LEGO, à l'exception des compagnies affiliées qui nous procurent des services auxquels l'enfant en a fait la demande. Formulaires photocopiés acceptés. **DE** Mit der folgenden Unterschrift erkläre ich, für mein Kind den Beitritt zum kostenlosen LEGO Club, der von der LEGO GmbH, D-85627 Grasturn, betrieben wird. Die Mitgliedschaft beinhaltet die Zusendung des LEGO Club Magazines und kann beiderseits jederzeit beendet werden. Mir der Mitgliedschaft im LEGO Club sind keinerlei Verpflichtungen verbunden. Das deutschsprachige LEGO Club Magazin wird nur an Adressen in Deutschland, Österreich und der Schweiz versendet. Eine Anmeldebestätigung kann nur per E-Mail geschickt werden. Das Magazin erscheint fünfmal jährlich. Dabei kann die Zustellung des ersten Heftes bis zu drei Monate dauern. Die Mitgliedschaft ist beidseitig jederzeit kündbar, ohne dass Ihnen Kosten entstehen. Sie können der verblichenen Nutzung Ihrer Daten jederzeit widersprechen, Kündigung und Widerspruch können Sie telefonisch erklären (00800 / 5346 5555, Anruf gebührenfrei. Kosten für Anrufe aus dem Mobilfunknetz können abweichen) oder an die LEGO GmbH senden. **NL** Het Nederlandse LEGO Club Magazine kan alleen worden gestuurd naar adressen in Nederland. Het lidmaatschap is 2 jaar geldig en geeft recht op toezending van het gratis LEGO Club Magazine en LEGO Club e-mails. Het eerste magazine zal binnen 12 tot 14 weken toegestuurd worden. Het lidmaatschap kan op ieder moment opgezegd worden en kan na 2 jaar gratis worden verlengd, tenzij LEGO met deze activiteit stopt. Uw gegevens worden uitsluitend gebruikt voor mailings van LEGO en zullen niet worden verkocht, verhuurd of op welke wijze dan ook verstrekt aan derden buiten de LEGO Groep, uitgezonderd de organisaties die namens ons optreden om de informatie te sturen waarvoor toestemming is verleend. **NO** Den norske utgaven av magasinet sendes kun til adresser i Norge. Medlemskap i klubben gjelder 12 år og inkluderer gratisutgaver av LEGO Club Magazine. Påregnet minimum opp til seks ukers leveringstid for første magasin. Ved å undertegne dette skjemaet, gir du ditt samtykke til at LEGO Club kan bruke opplysningene om barnet ditt i LEGO forsendelser. Dataene vil utelukkende bli brukt i LEGO forsendelser og vil ikke bli solgt, utleid eller på annen måte gittes tilgjengelig for selskaper utenfor LEGO gruppen, unntatt selskaper som er våre agenter og som hjelper oss å tilby tjenestene barnet etterspør. Dette skjemaet gjelder for ett gratis medlemskap per person, gruppe eller organisasjon. **SE** Den svenska versionen av tidningen kan endast skickas till adresser i Sverige. Club-medlemskapet är giltigt i 2 år och innefattar gratis exemplar av LEGO Club Magazine. Våningen räknas med minimum 6 veckor för leverans av din första tidning. Genom att skicka in det här formuläret godkänner du att LEGO Club använder barnets uppgifter för LEGO utskick. Uppgifterna kommer bara att användas för LEGO utskick och kommer inte att säljas, hyras ut eller vidarebefordras till något företag som inte tillhör LEGO Gruppen, med undantag av företag som agerar som våra ombud för att tillhandahålla tjänster som barnet har begärt. Den här kupongen gäller för ett gratis medlemskap per person, grupp eller organisation. **FR** En complétant ce bulletin d'adhésion, vous acceptez que LEGO Club utilise les données relatives à votre enfant pour l'envoi de courriers concernant LEGO. Ces données seront uniquement utilisées pour l'envoi d'information concernant LEGO et ne seront ni vendues, ni louées, ni utilisées par d'autres sociétés que le groupe LEGO, à l'exception des sociétés agissant pour le compte de LEGO en tant que sous-traitant de services divers. L'abonnement au LEGO Club est valable pour une période de 2 ans. Il inclut l'envoi par courrier du magazine LEGO Club et par email des newsletters. Un délai de 6 à 14 semaines est à prévoir pour la réception de votre premier magazine. Ce bulletin d'adhésion gratuit est valable pour l'inscription d'une seule personne. Les photocopies sont acceptées. **ATTENTION!** Le bulletin d'adhésion doit être rempli et signé par un parent ou un tuteur.

Parent's signature • Signature d'un parent ou d'un tuteur • Unterschrift Erziehungsberechtigter / Handtekening ouders • Foreldres/foresattes underskrift • Förälders / förmyndares underskrift

Date  
Datum  
Date

B116



# WIN!

Go to [www.LEGOsurvey.com/product](http://www.LEGOsurvey.com/product) to fill out a survey for a chance to win a cool LEGO® Product. No purchase necessary. Open to all residents where not prohibited.

 [www.LEGO.com](http://www.LEGO.com)



# [www.LEGOsurvey.com/product](http://www.LEGOsurvey.com/product)

## GEWINNE!

Nimm an der Umfrage auf [www.LEGOsurvey.com/product](http://www.LEGOsurvey.com/product) teil und hab die Chance ein cooles LEGO® Produkt zu gewinnen! Die Teilnahme am Gewinnspiel führt zu keinerlei Kaufverpflichtungen. Teilnahme in allen nicht ausgeschlossenen Ländern möglich.

## WIN!

Ga naar [www.LEGOsurvey.com/product](http://www.LEGOsurvey.com/product), vul een enquêteformulier in en maak kans op een cool LEGO® product.

Geen aankoopverplichting. Iedereen mag deelnemen, uitgezonderd ingezetenden van landen waar een enquêteverbod geldt.

## GAGNE!

Visite [www.LEGOsurvey.com/product](http://www.LEGOsurvey.com/product) pour répondre à un questionnaire et avoir une chance de gagner un produit LEGO® très cool!

Aucune obligation d'achat. Ouvert à tous les résidents des pays autorisés.

## 当てよう!

[www.LEGOsurvey.com/product](http://www.LEGOsurvey.com/product) にアクセスして、アンケートにご記入ください。当選者にはレゴ製品を差し上げます。

お買い上げの必要はありません。禁止されていない限り、すべての皆様にご利用いただけます。