



# TECHNIC

8256





1

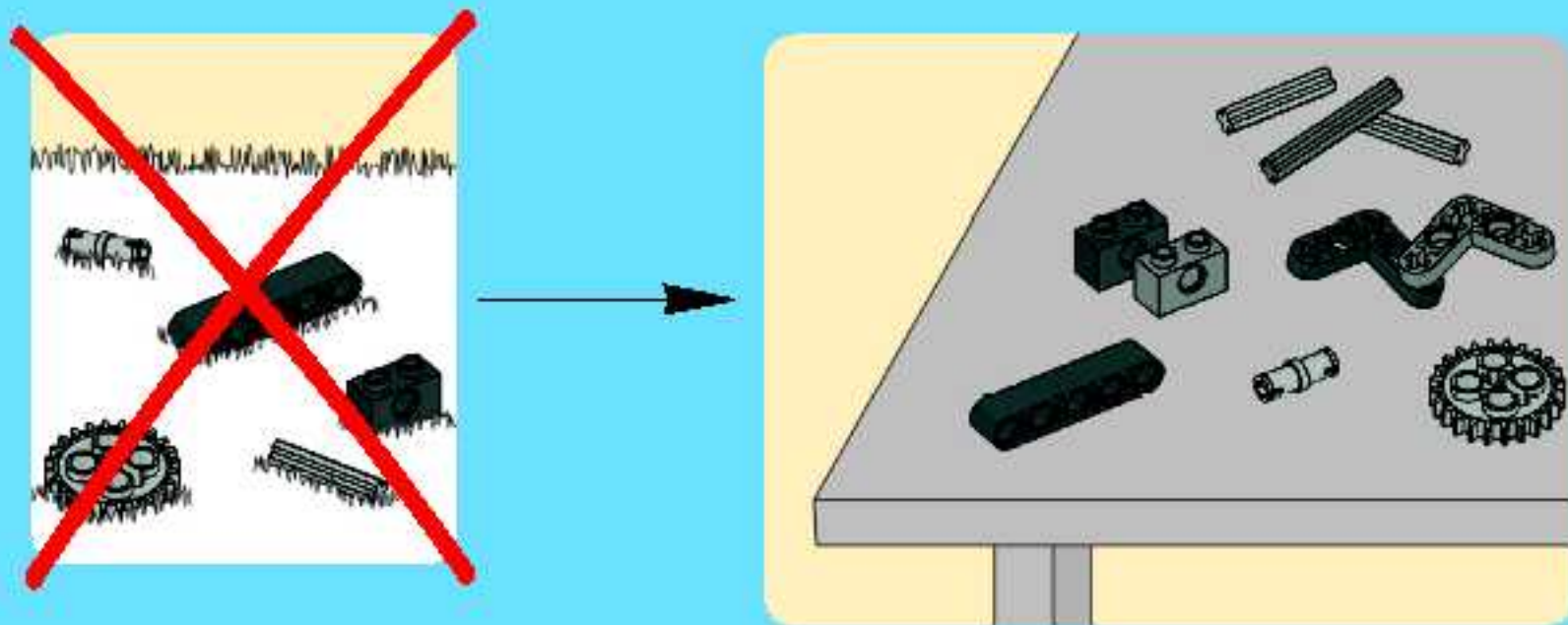

2

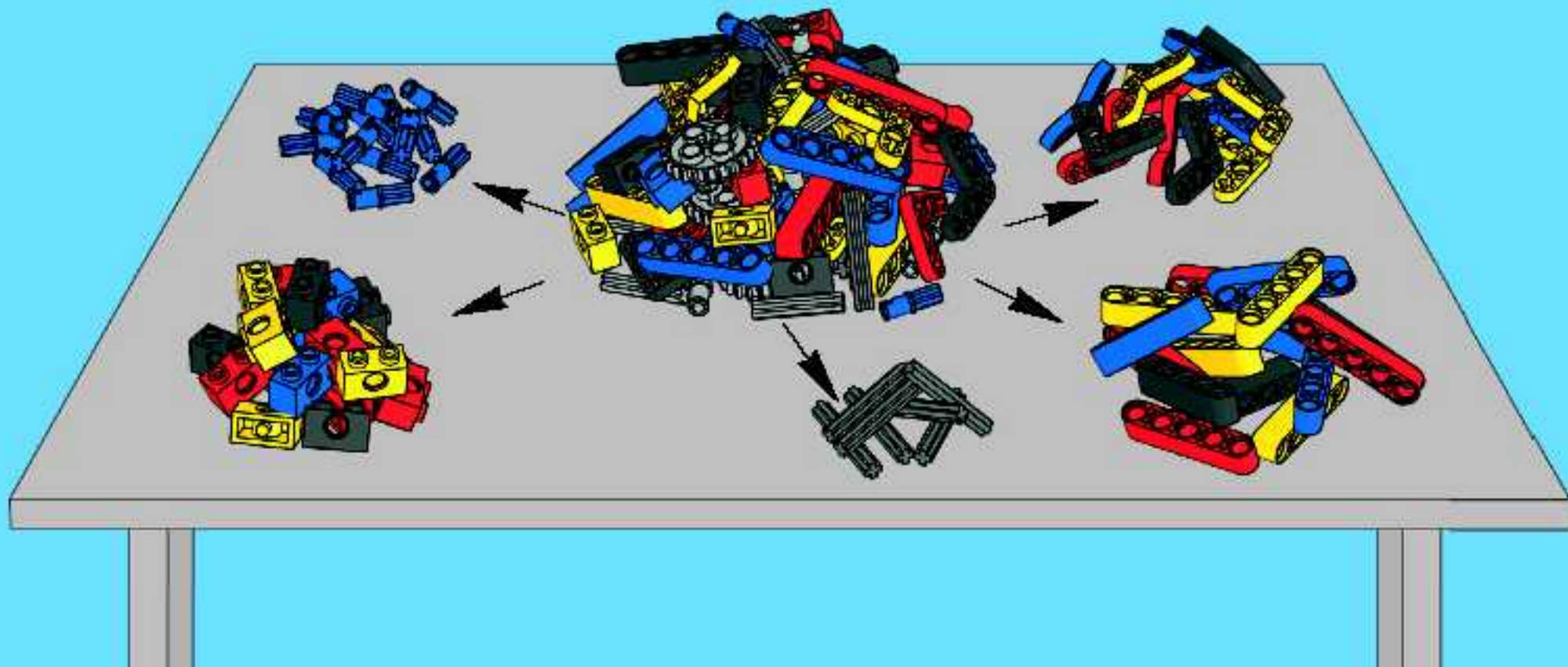

2

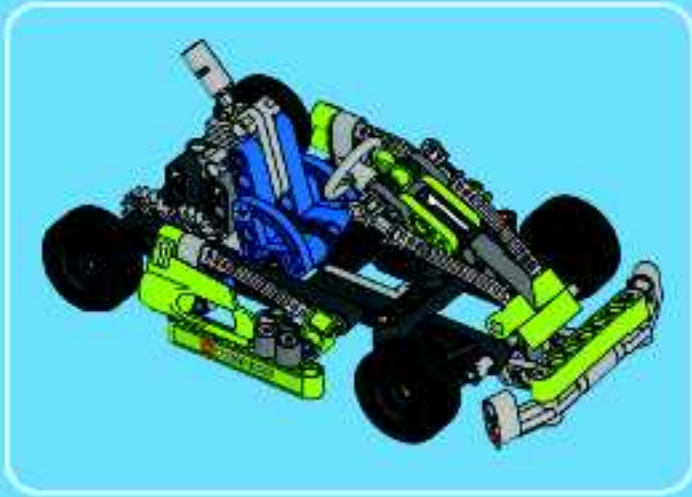

1





2

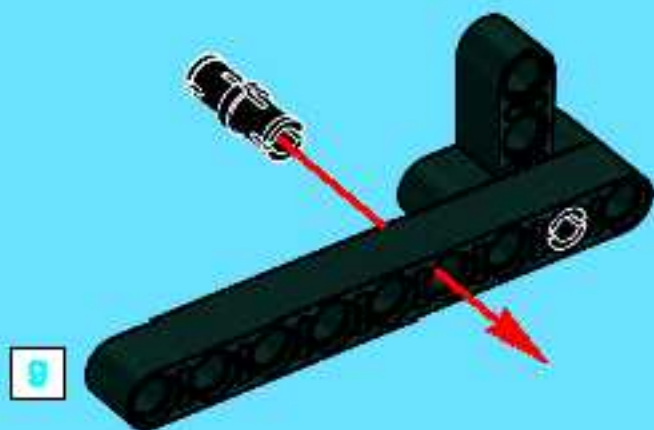

4



3

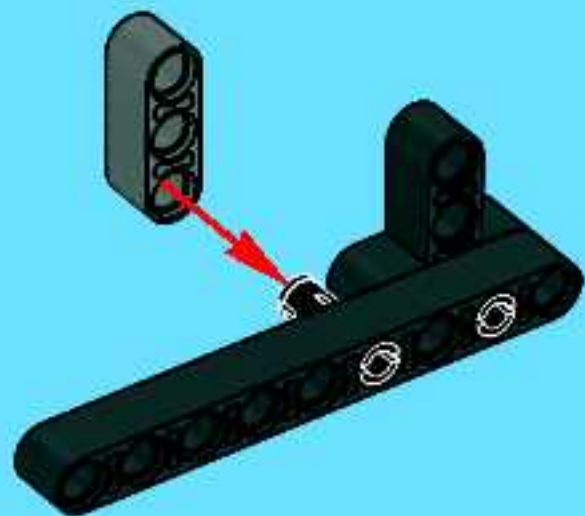

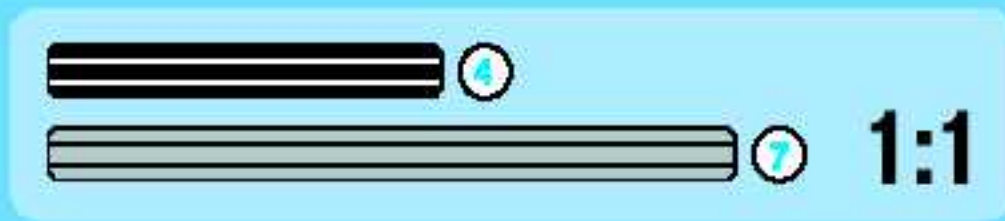
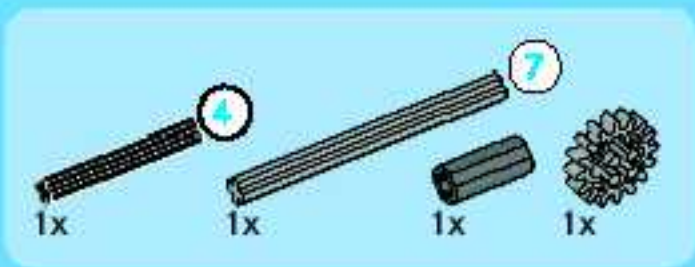

4

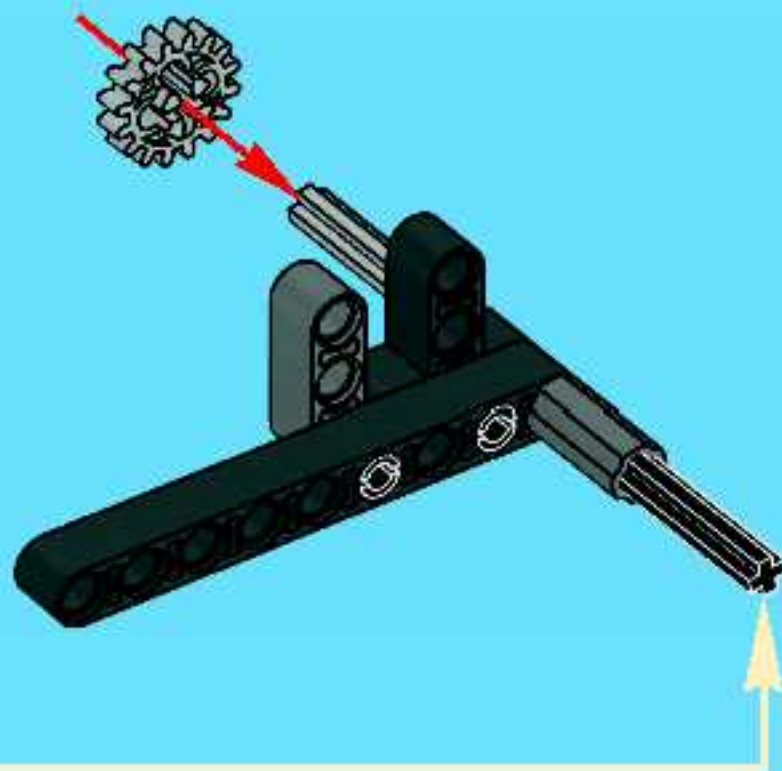
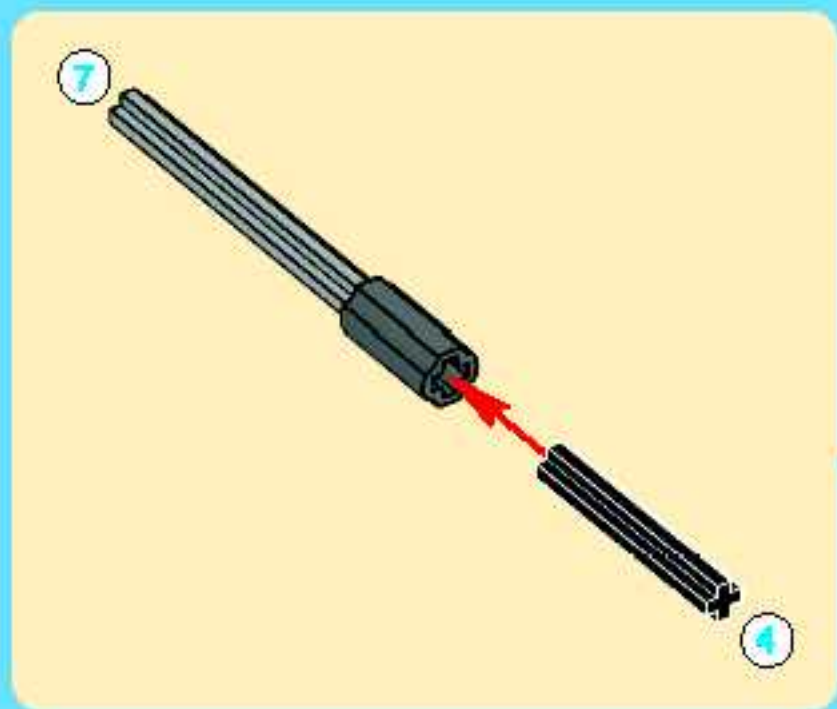



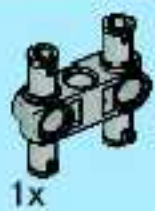

5

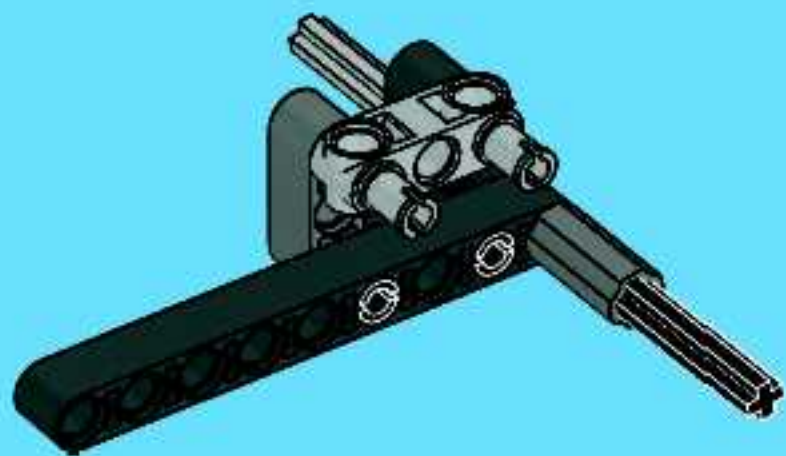

6

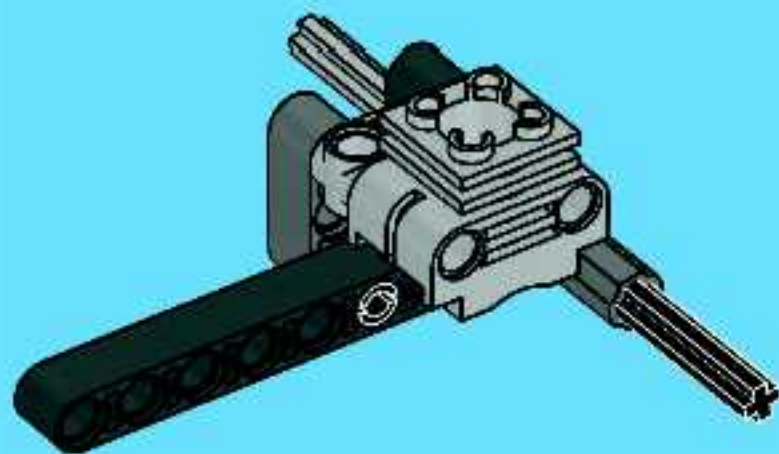



7

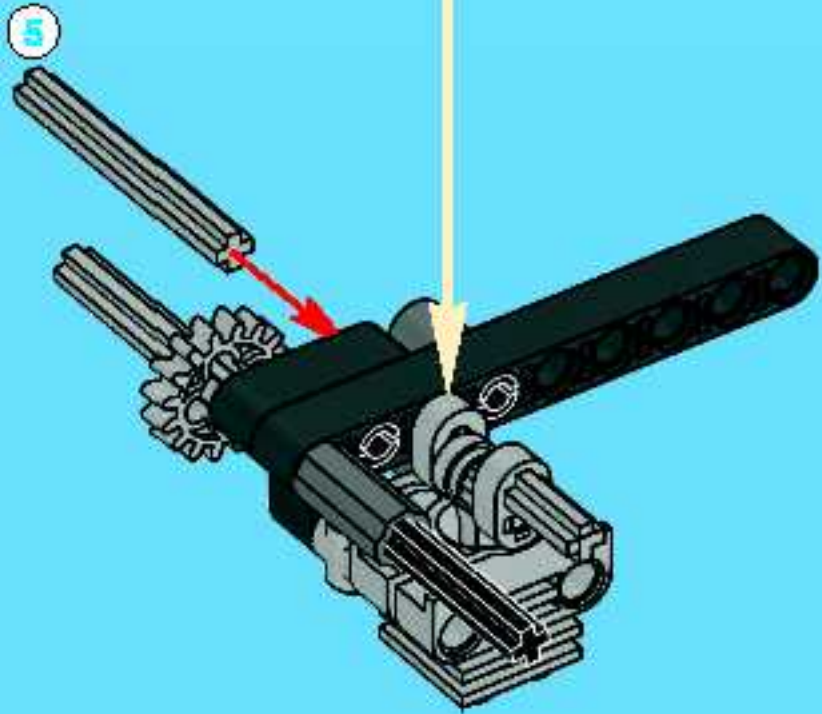
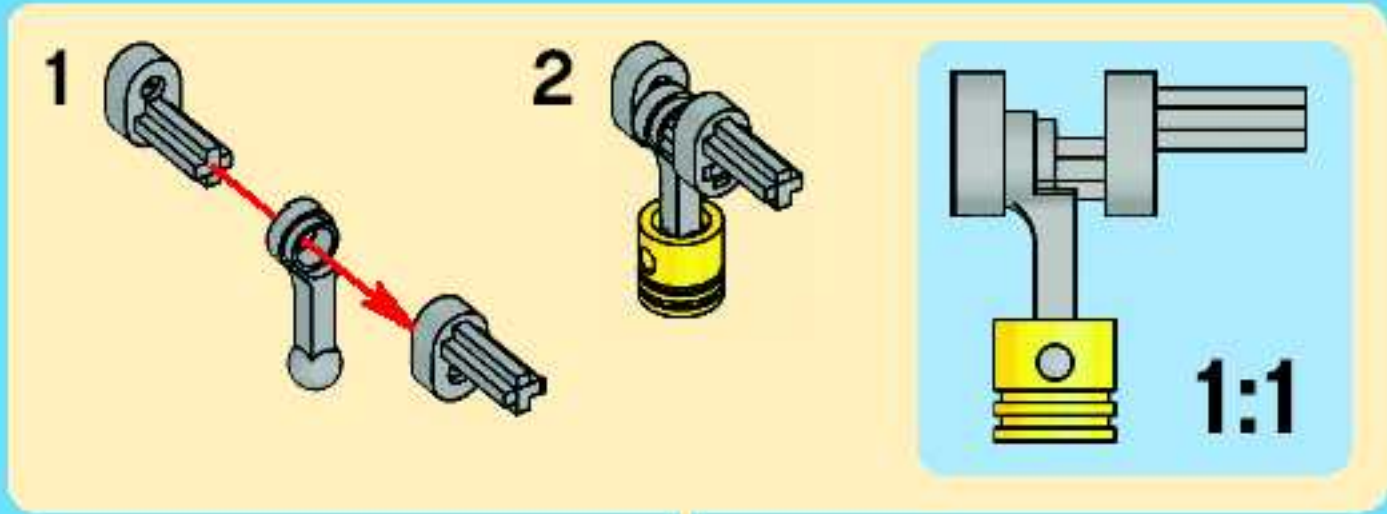



8

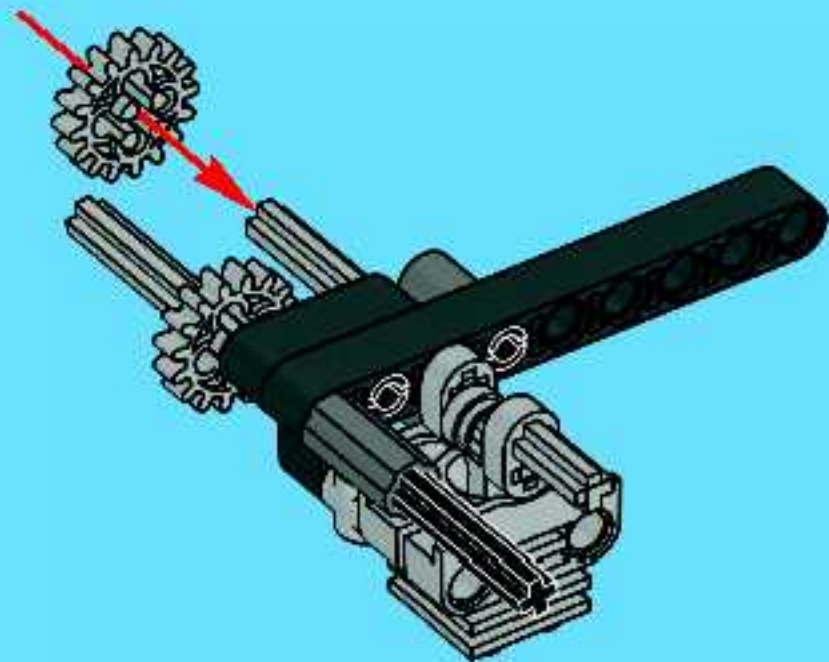

8



9

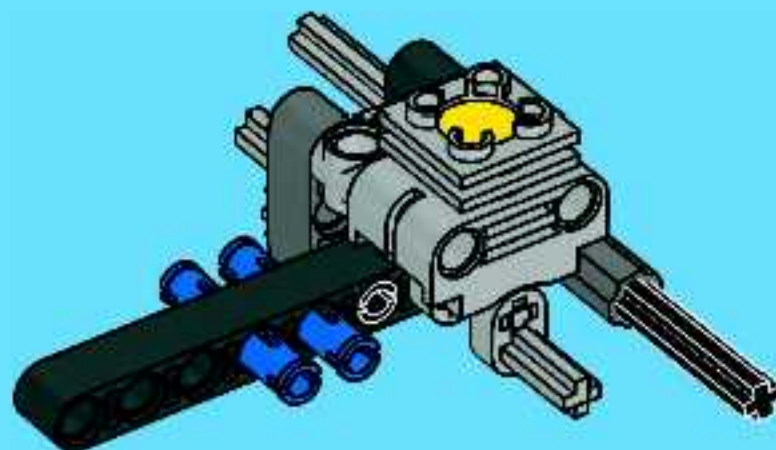





10

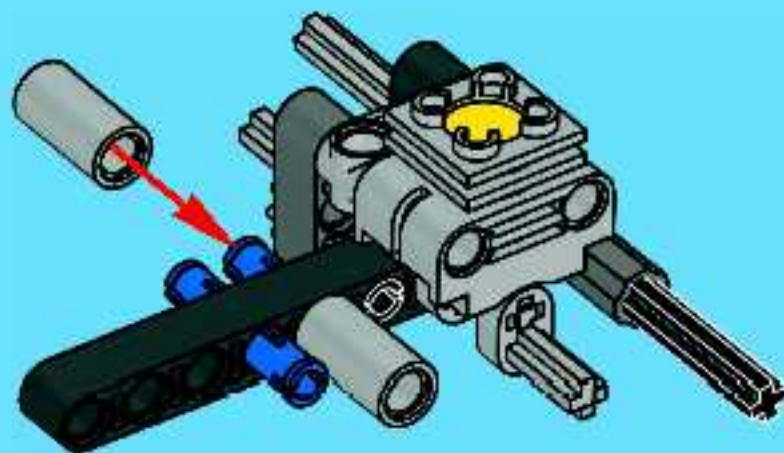

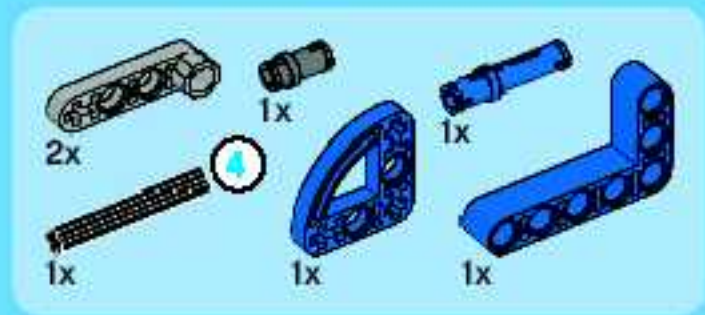

11

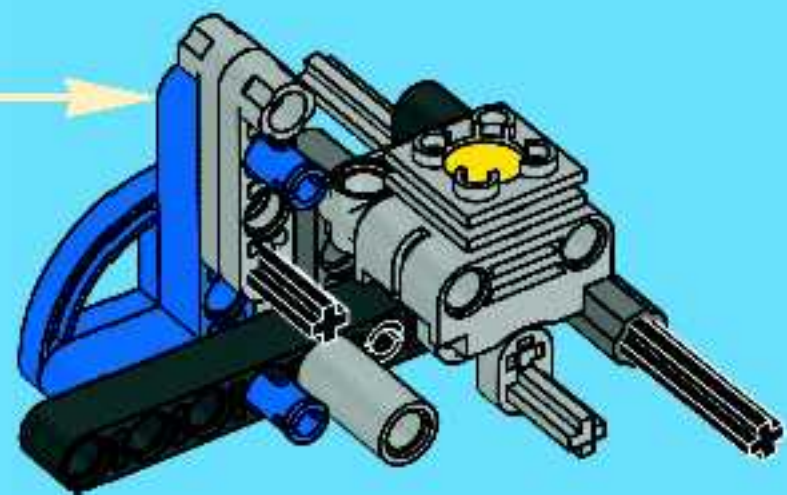
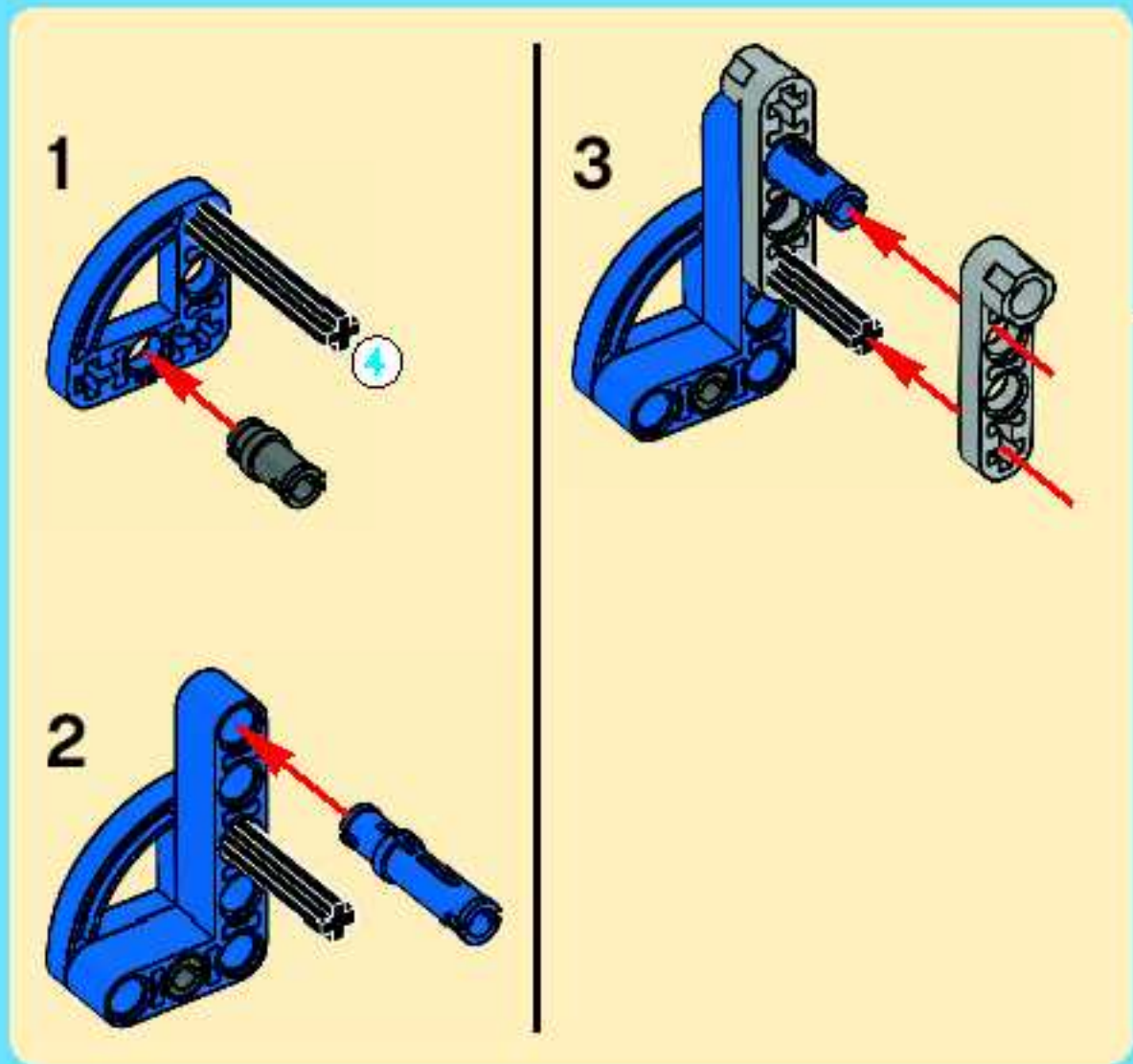

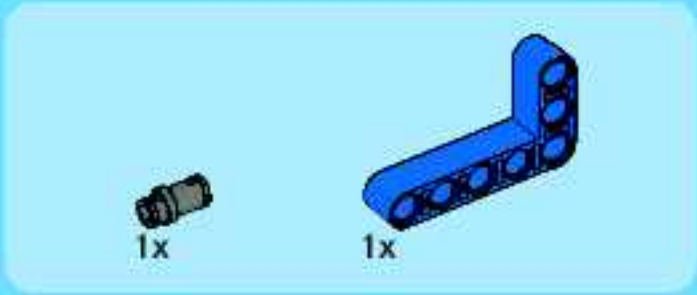

12

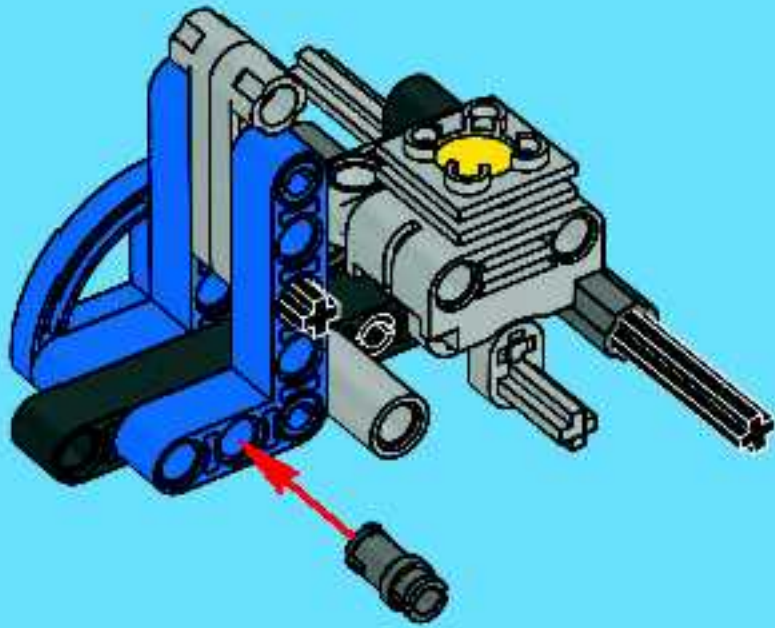

13

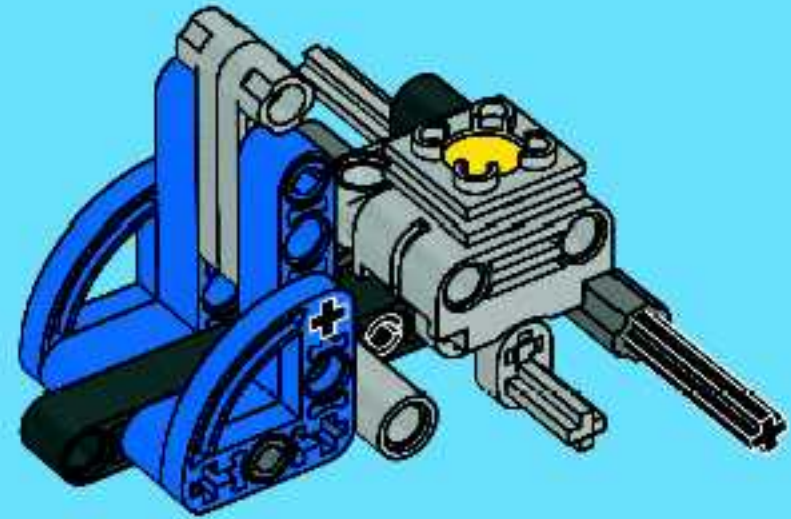



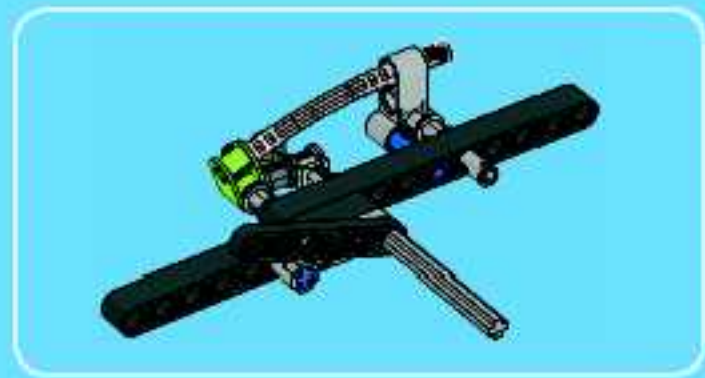

1

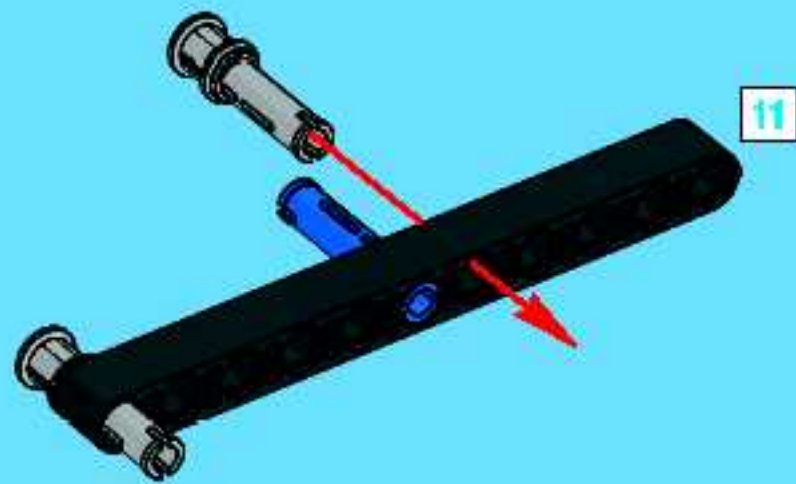



1x



2x

2

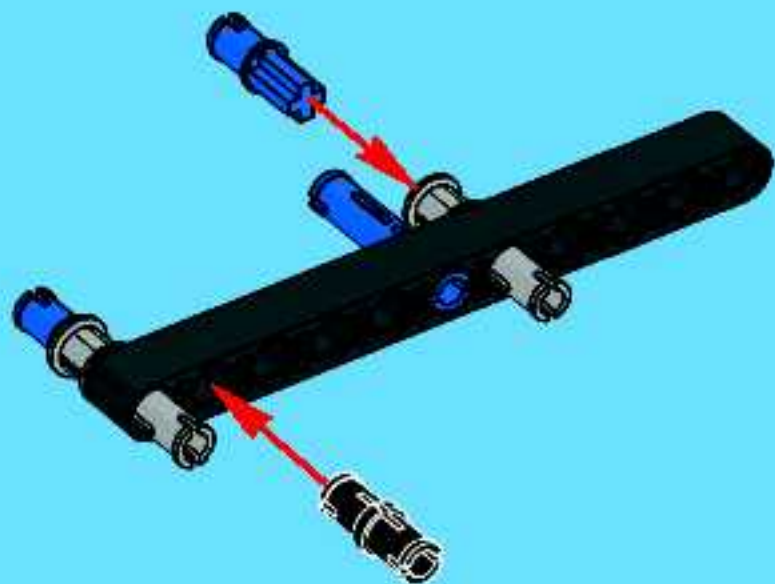

1x



1x



1x

3

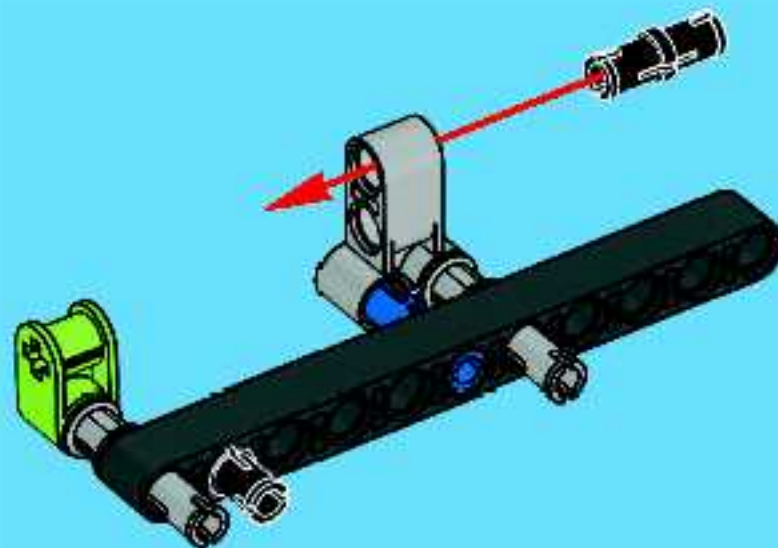



4

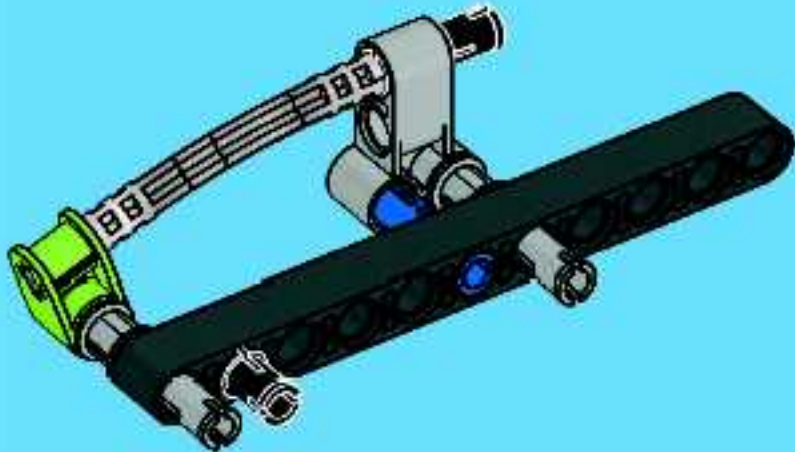

5

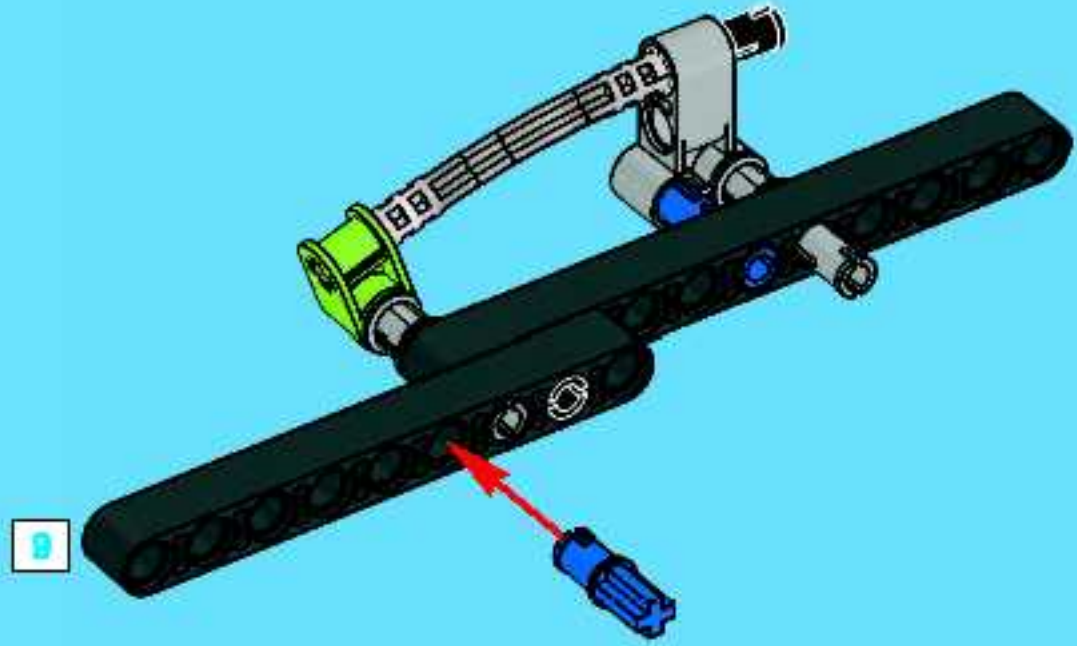





1x

6

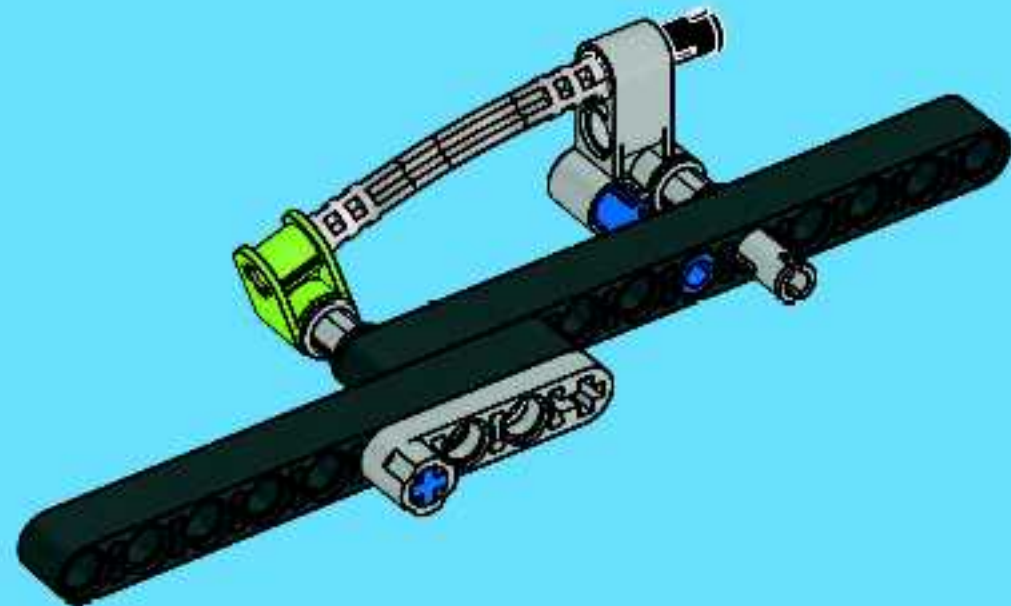

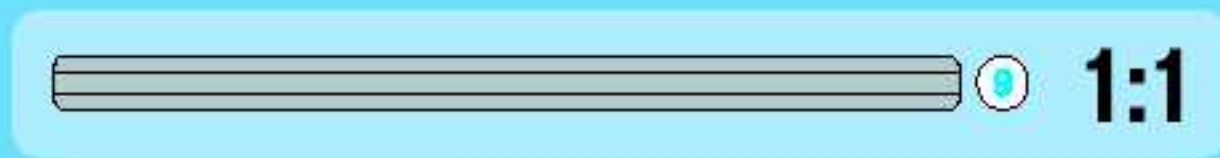
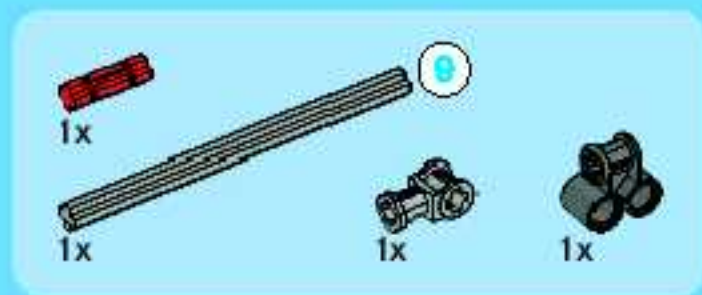

7

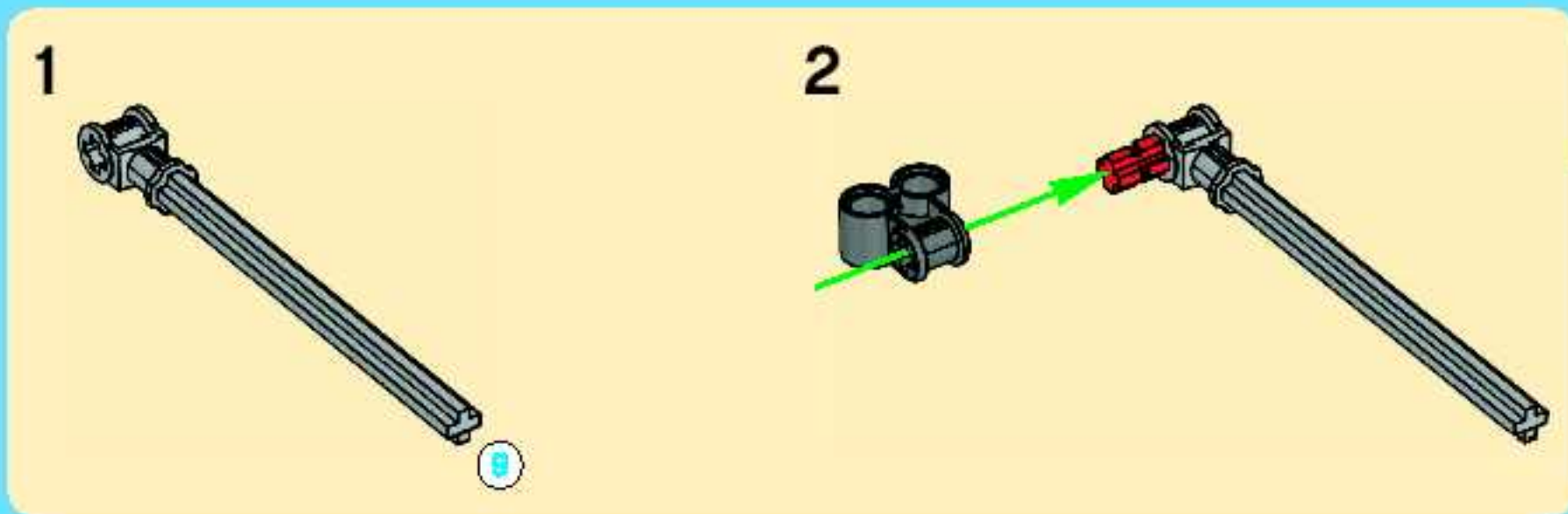

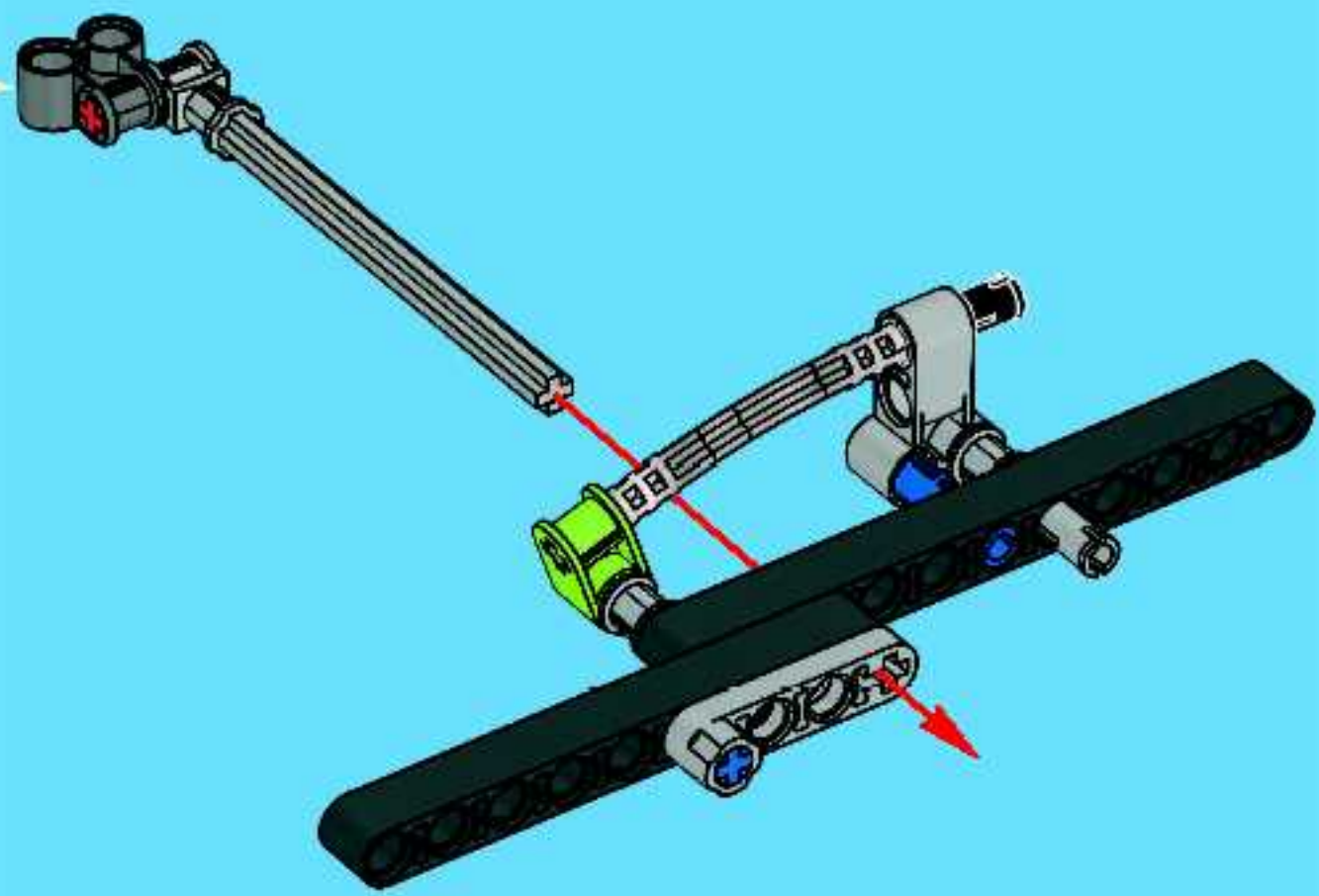





14

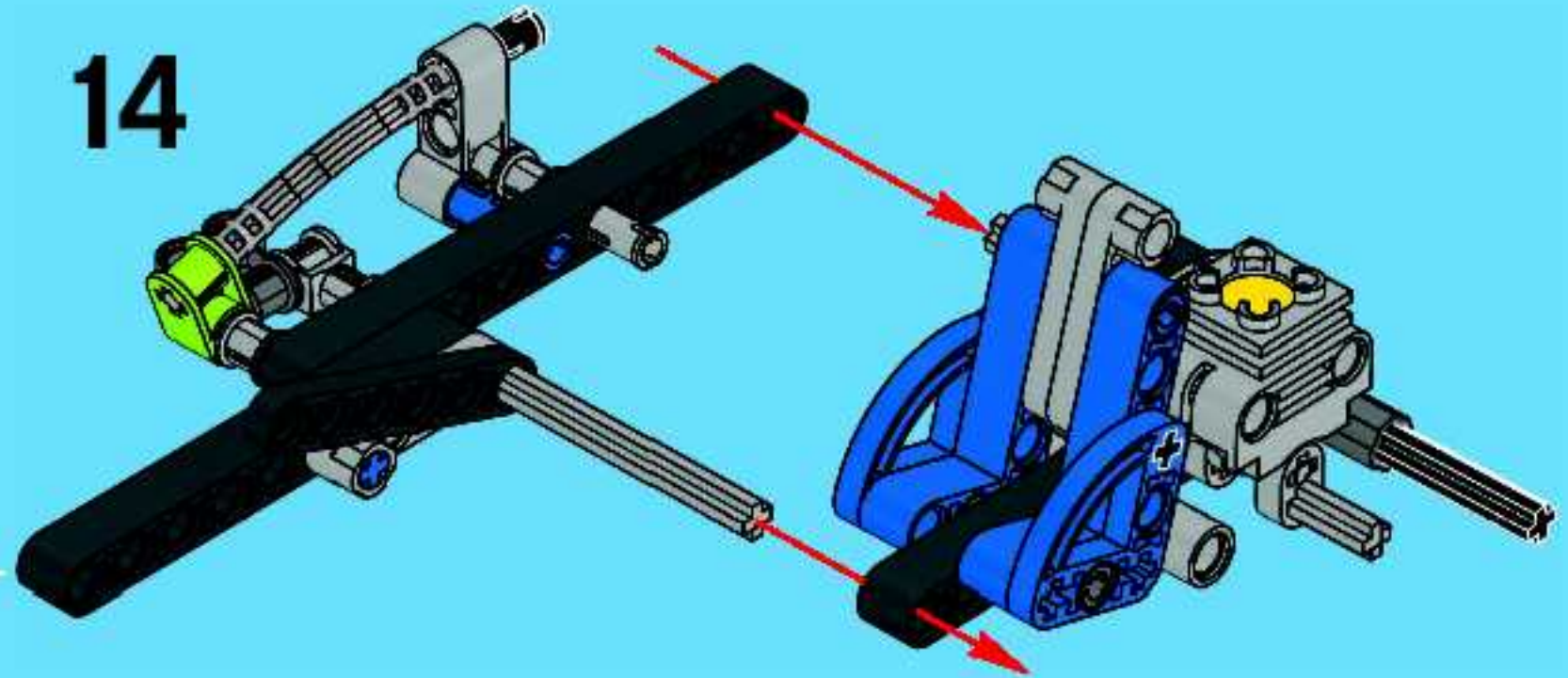

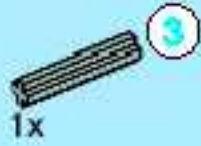

1:1

15

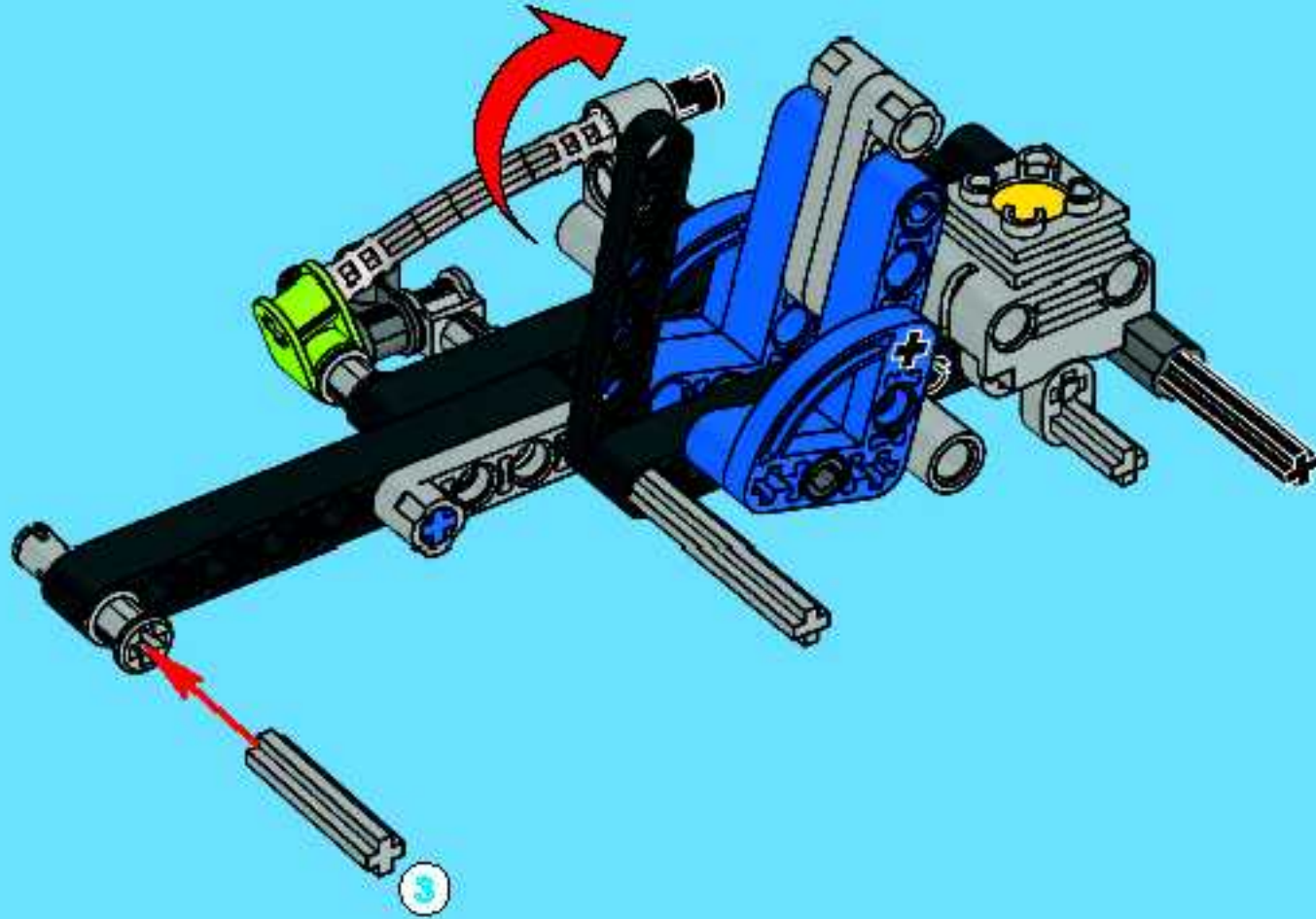



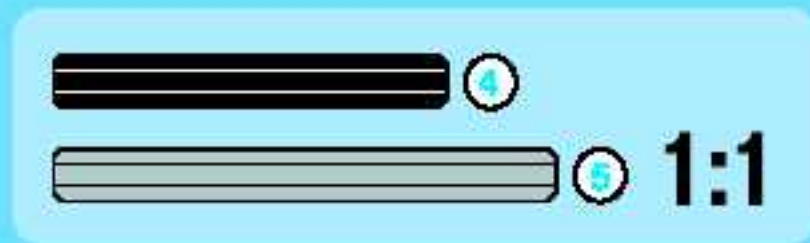
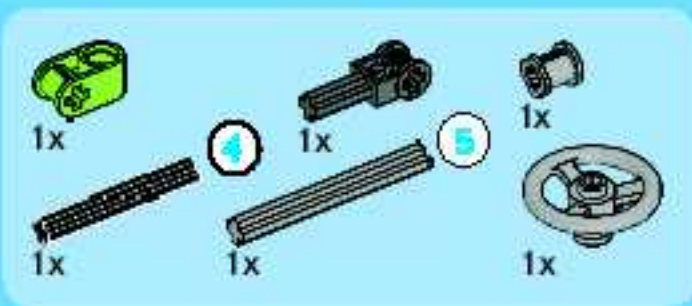

**16**

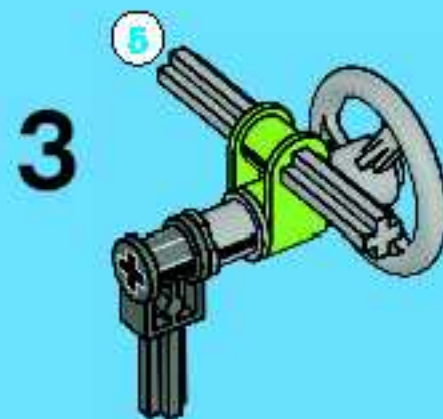
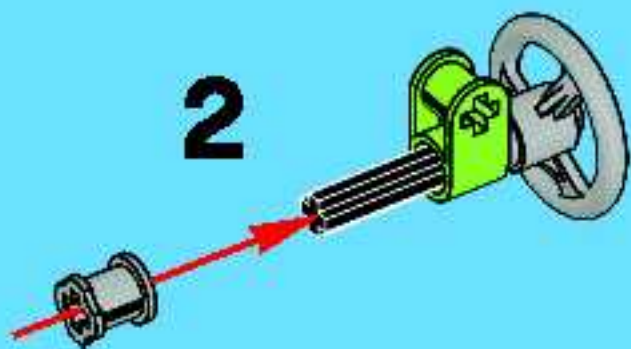
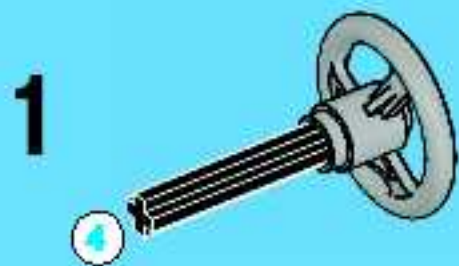

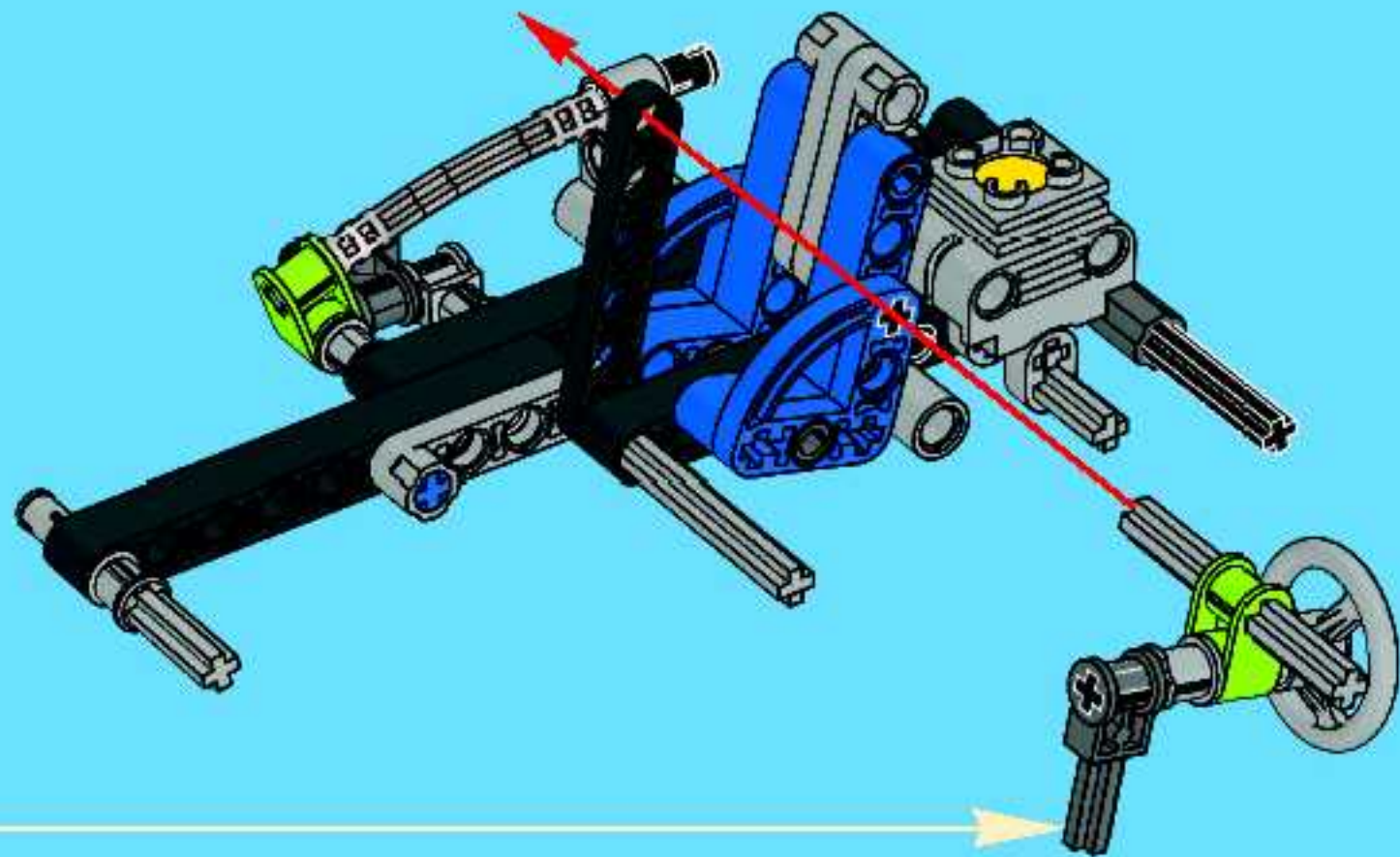



1x



1x

# 17

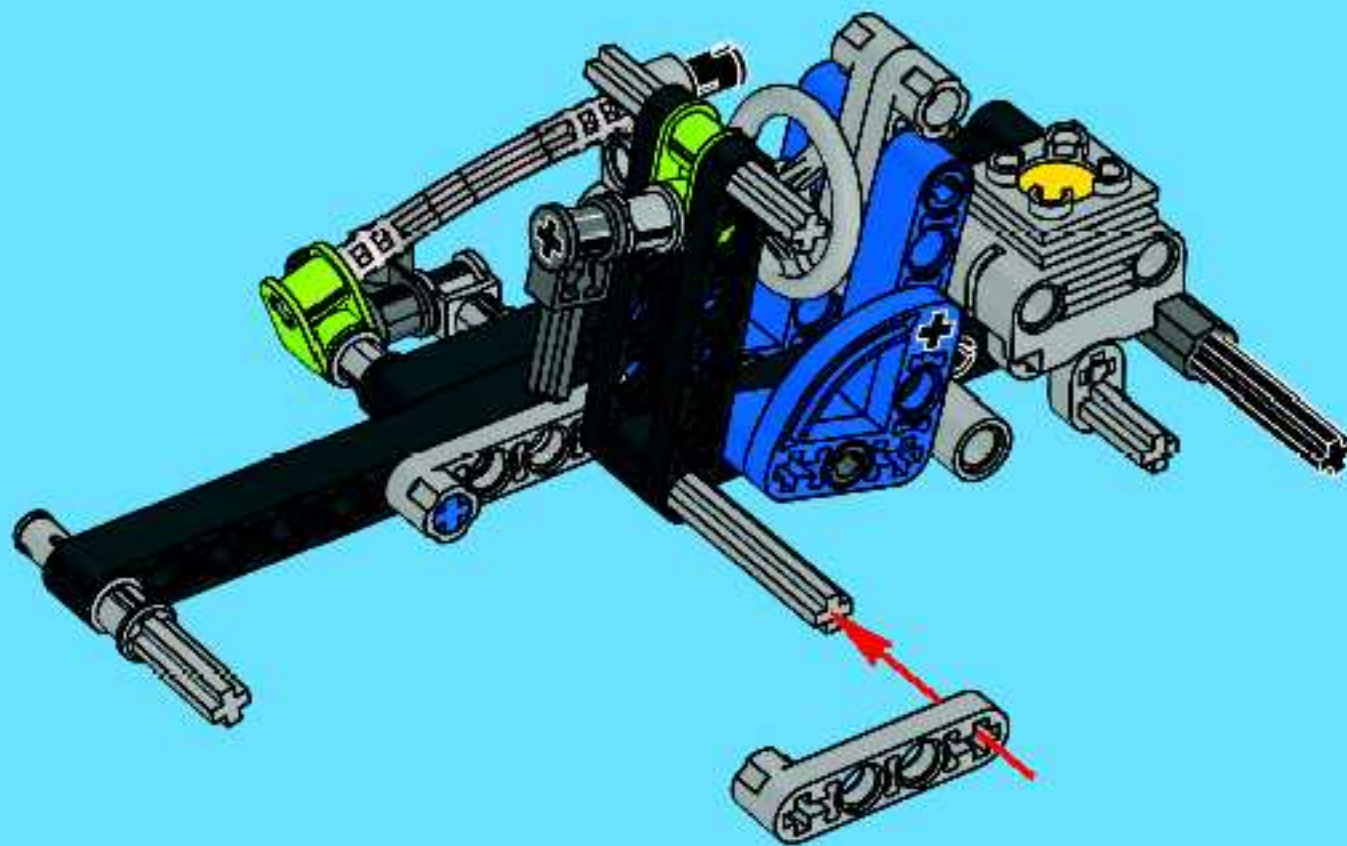





1x

# 18

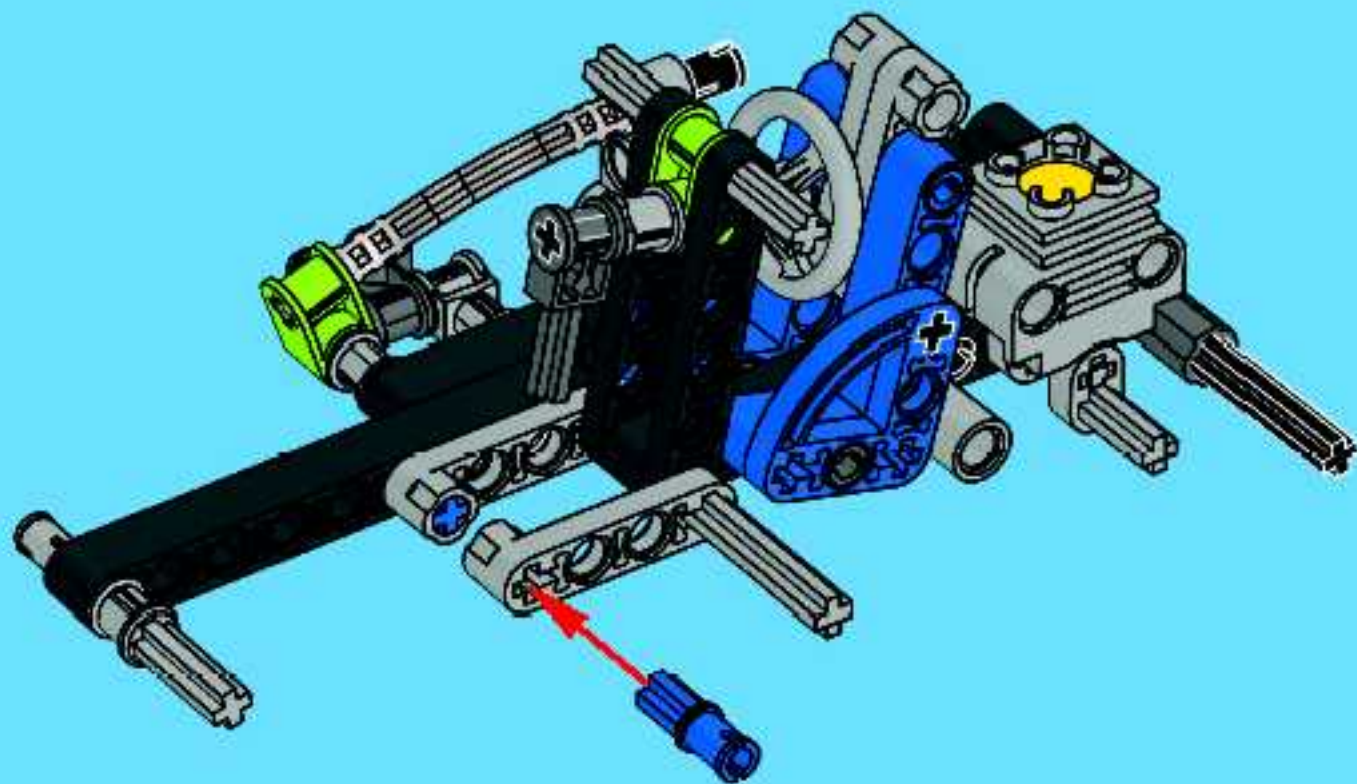

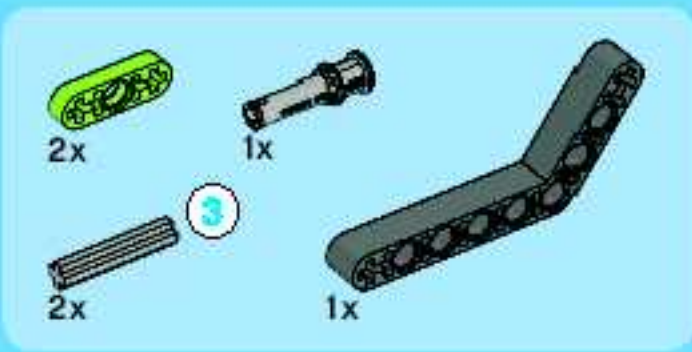

19

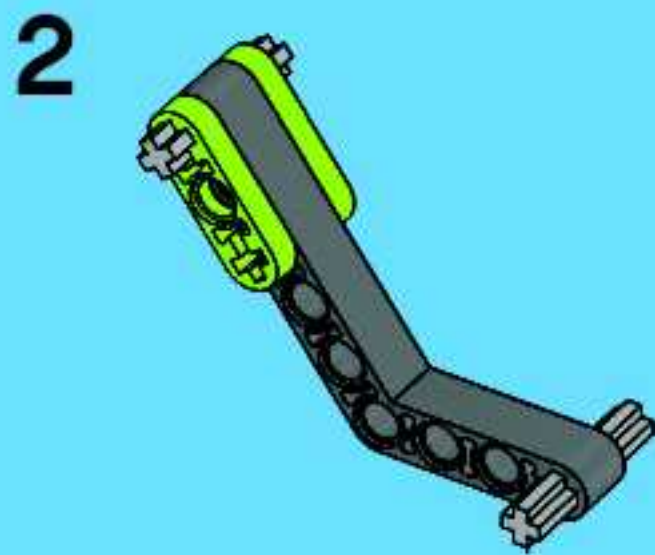
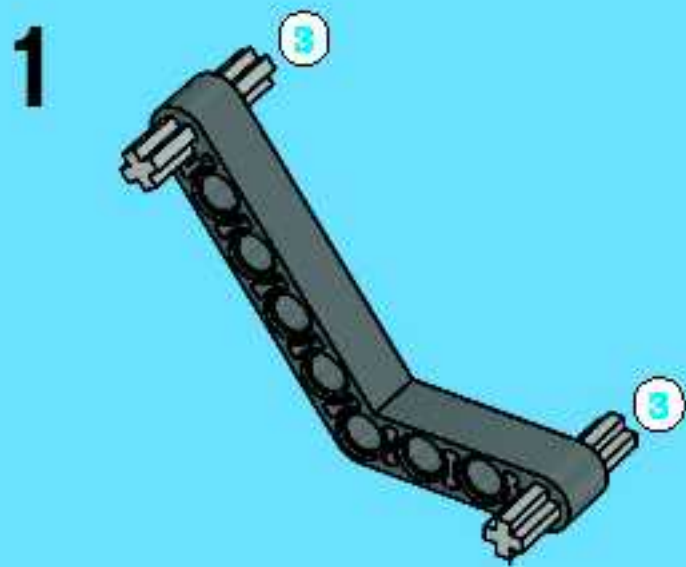

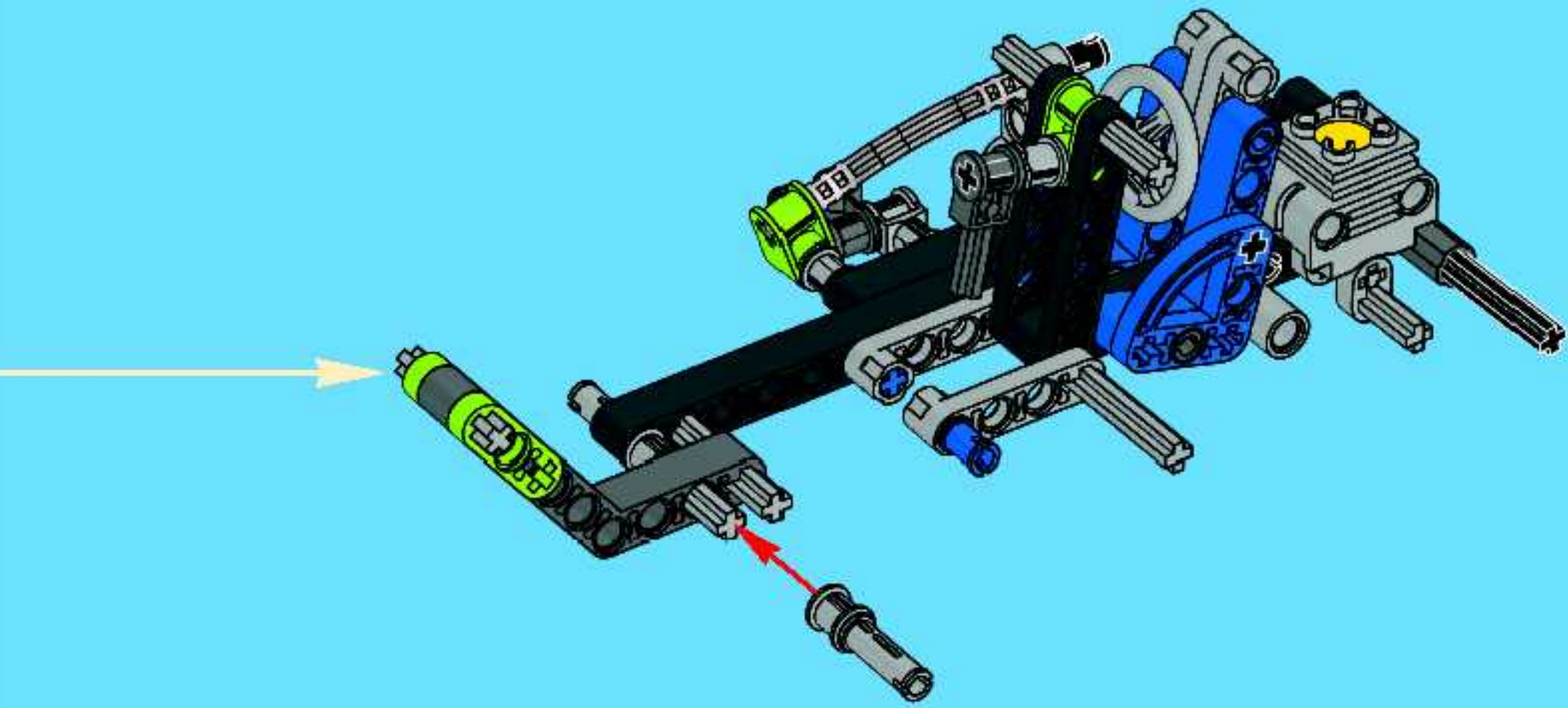



20

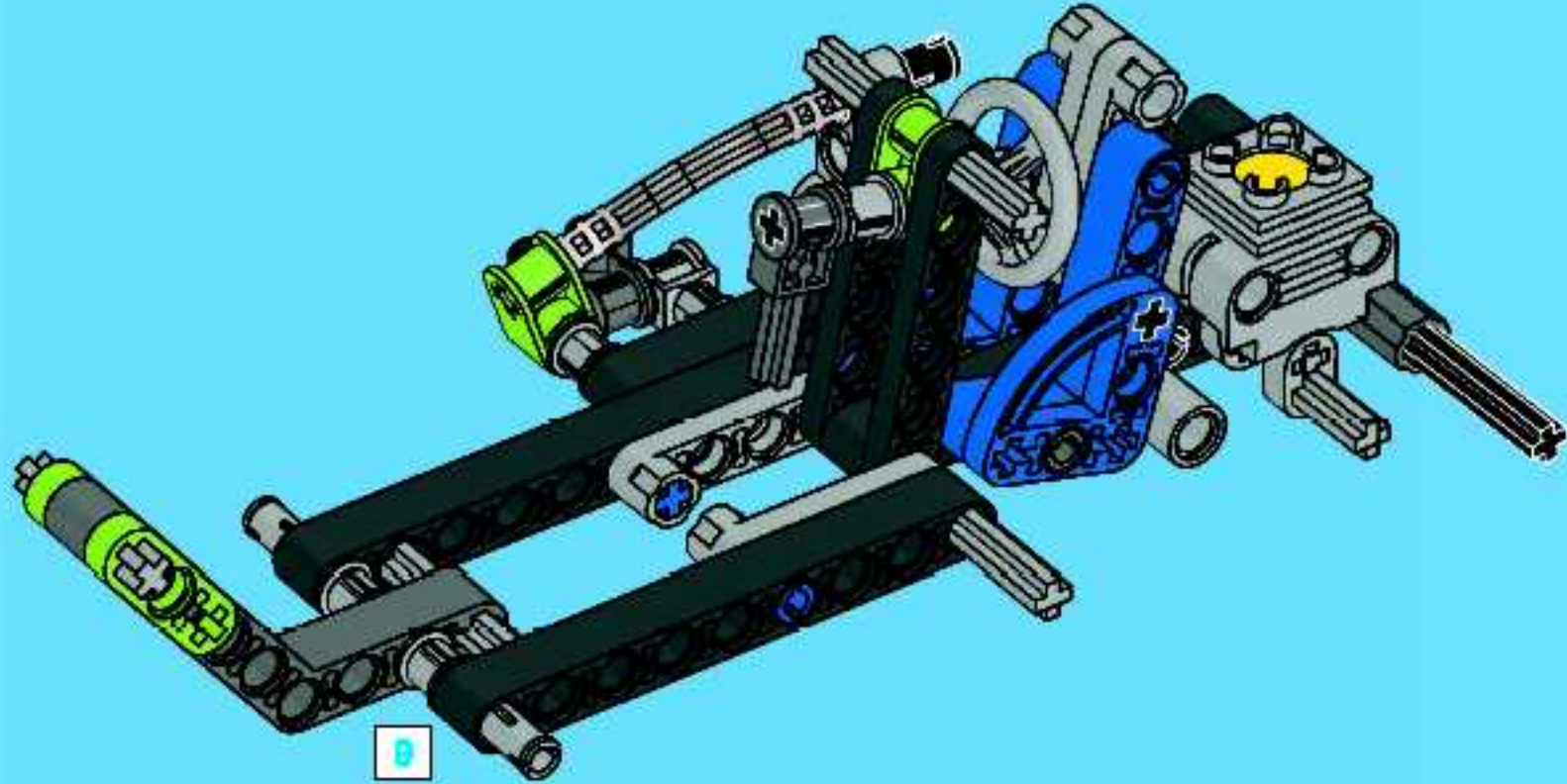





1x

# 21

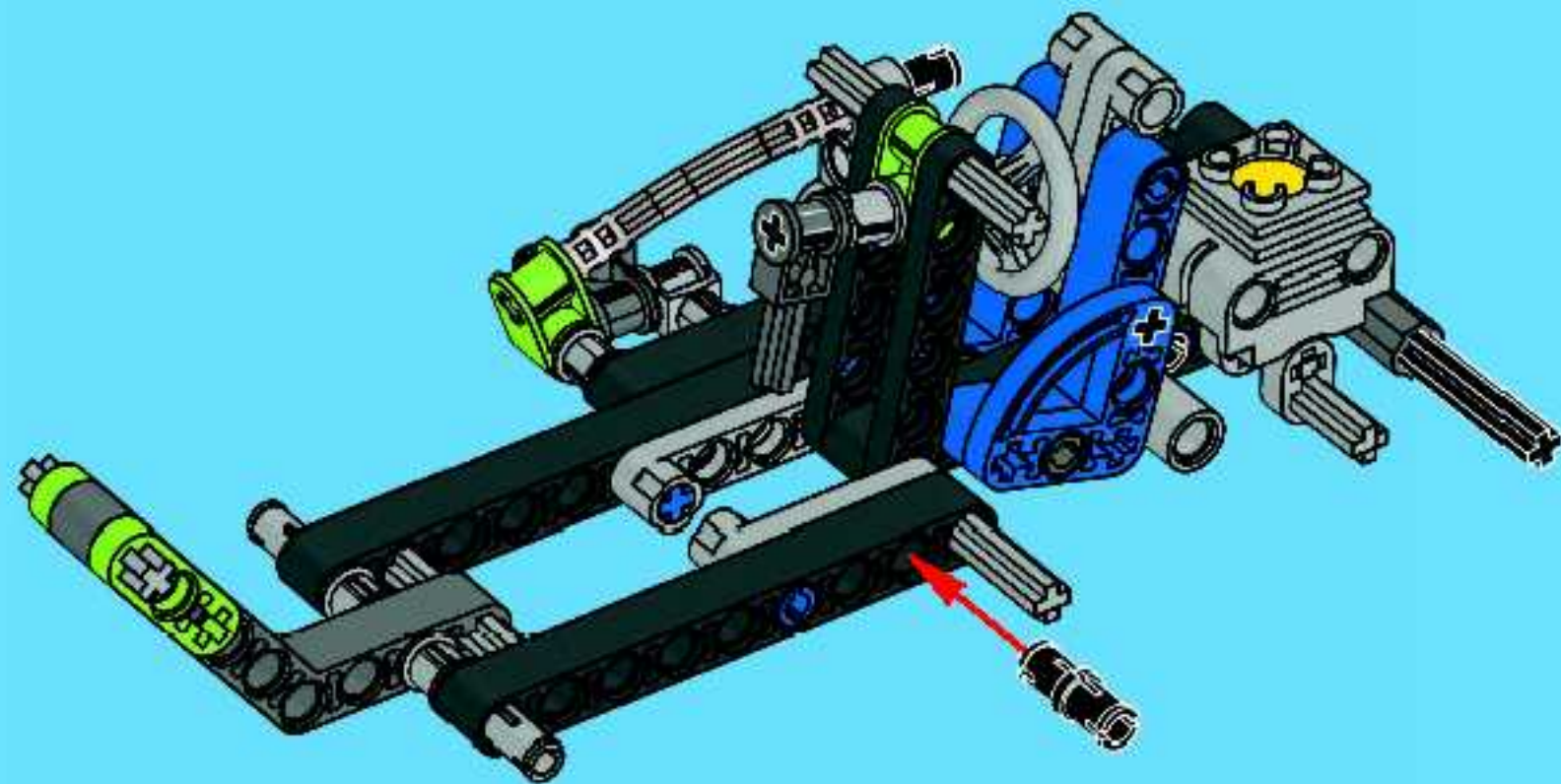



22

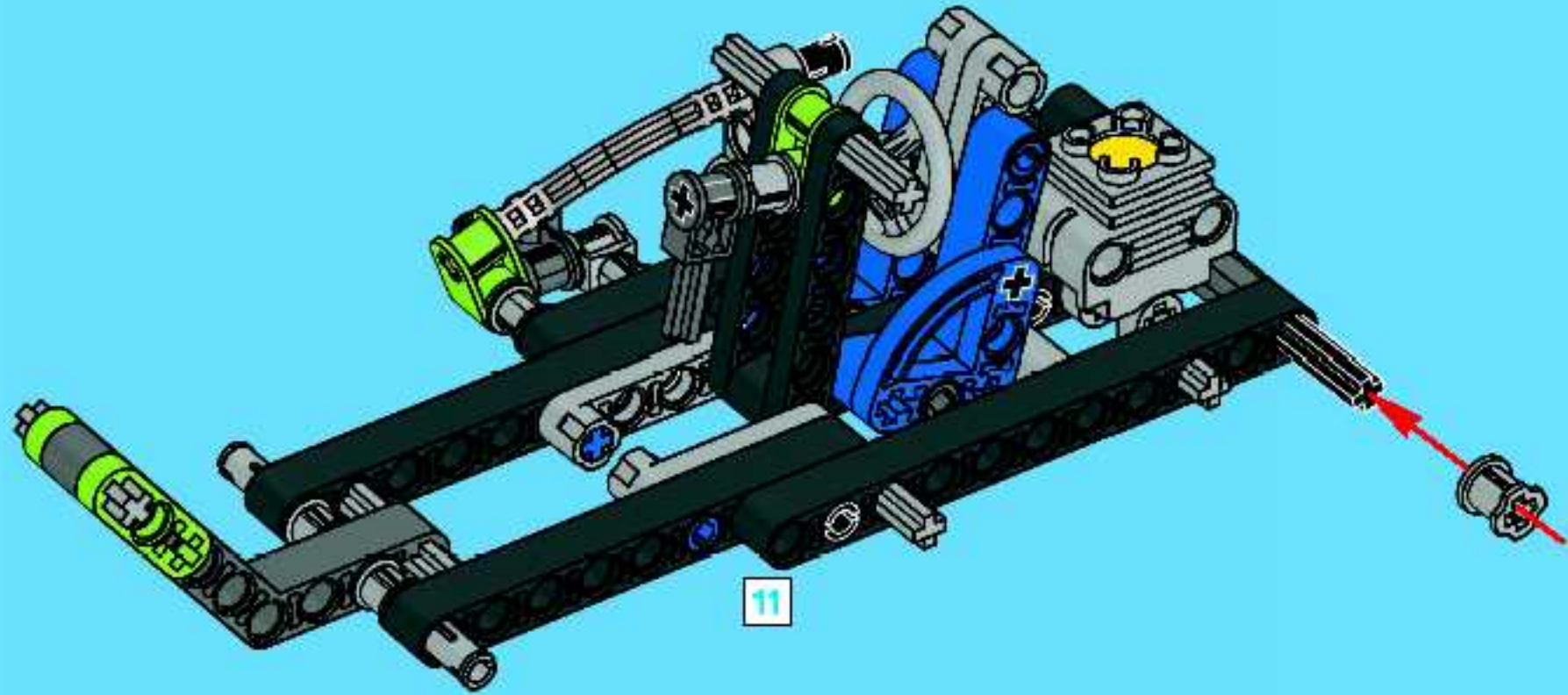



2x



1x

# 23

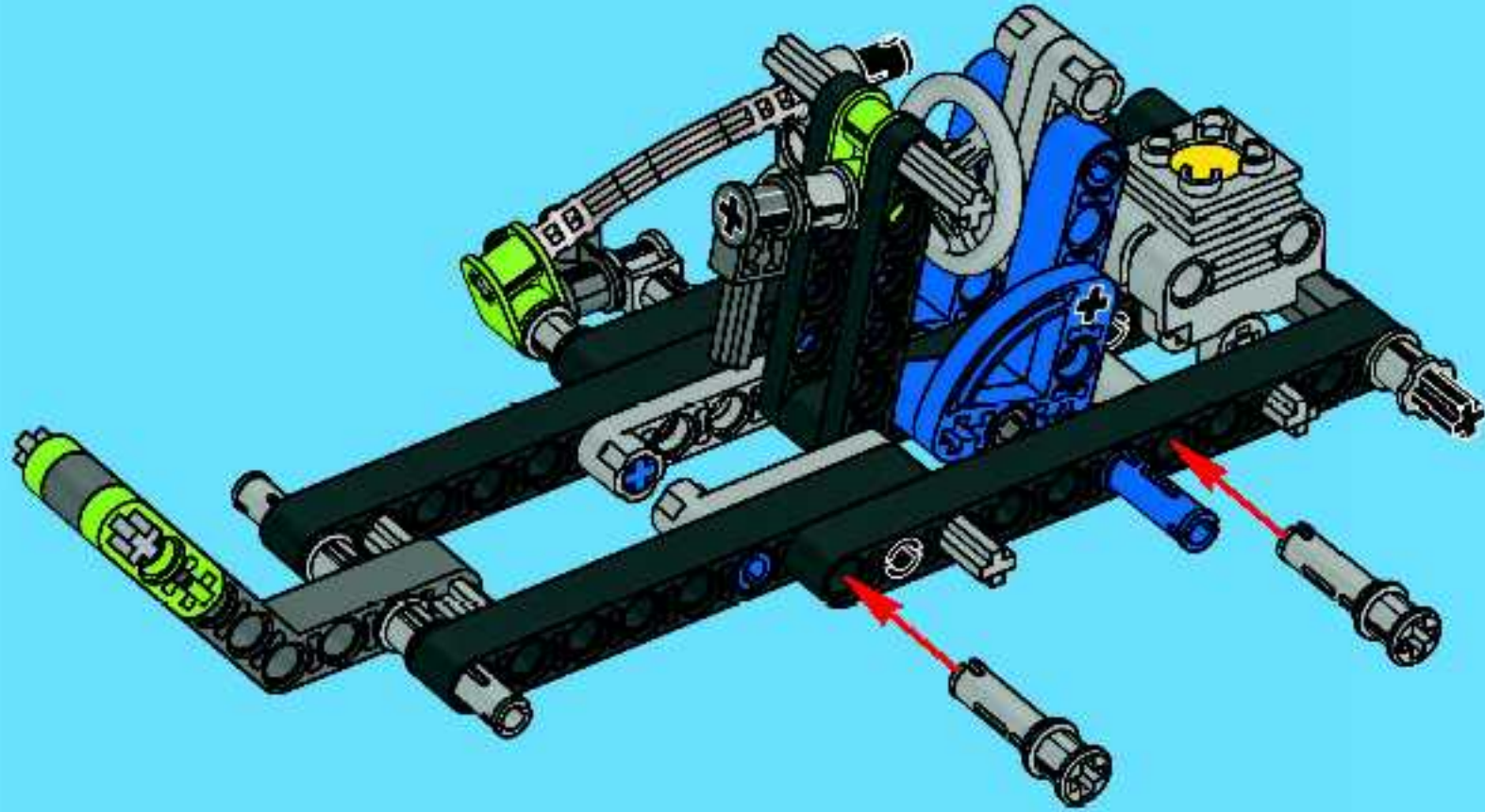





24

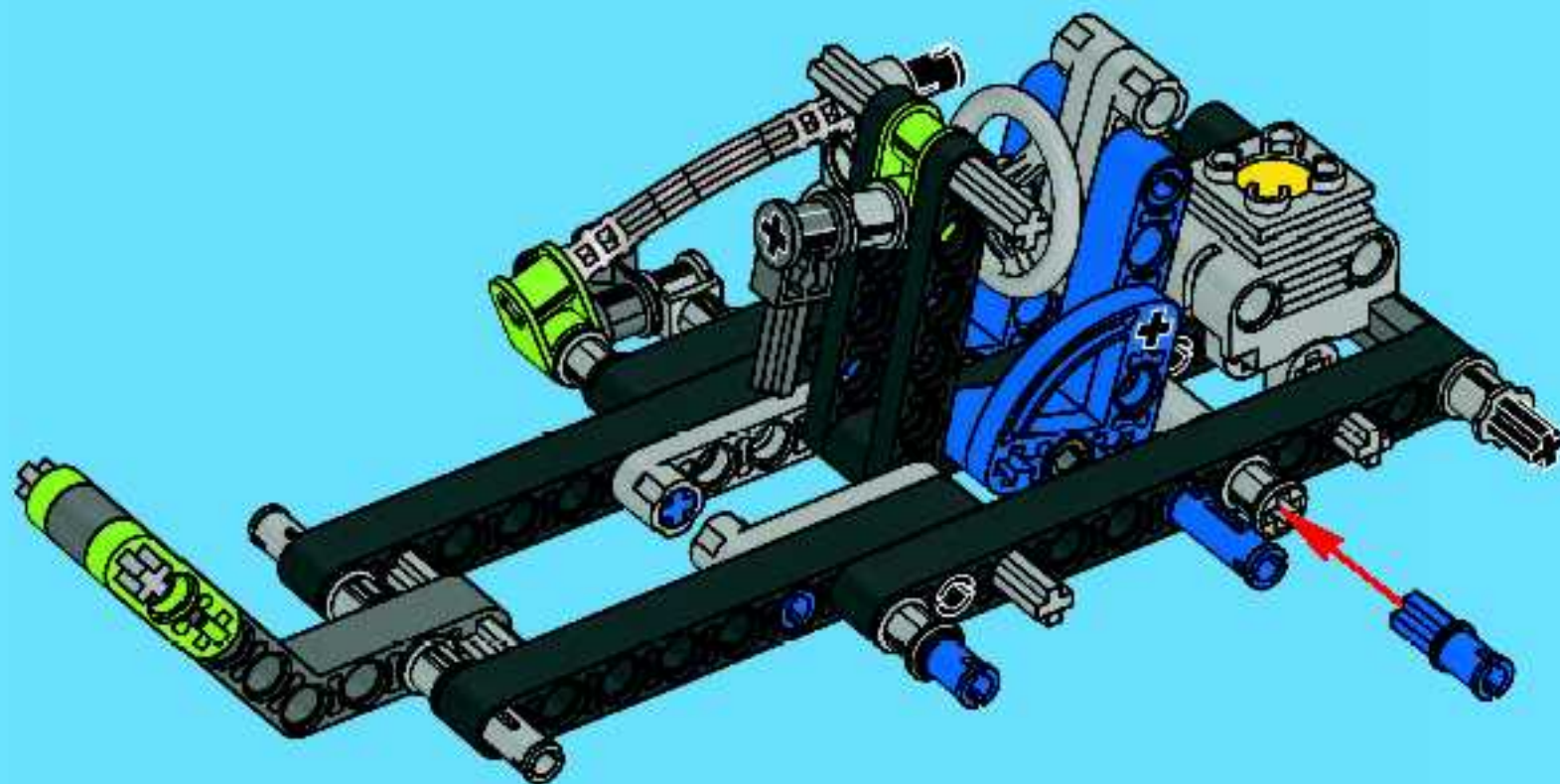





1x



1x

# 25

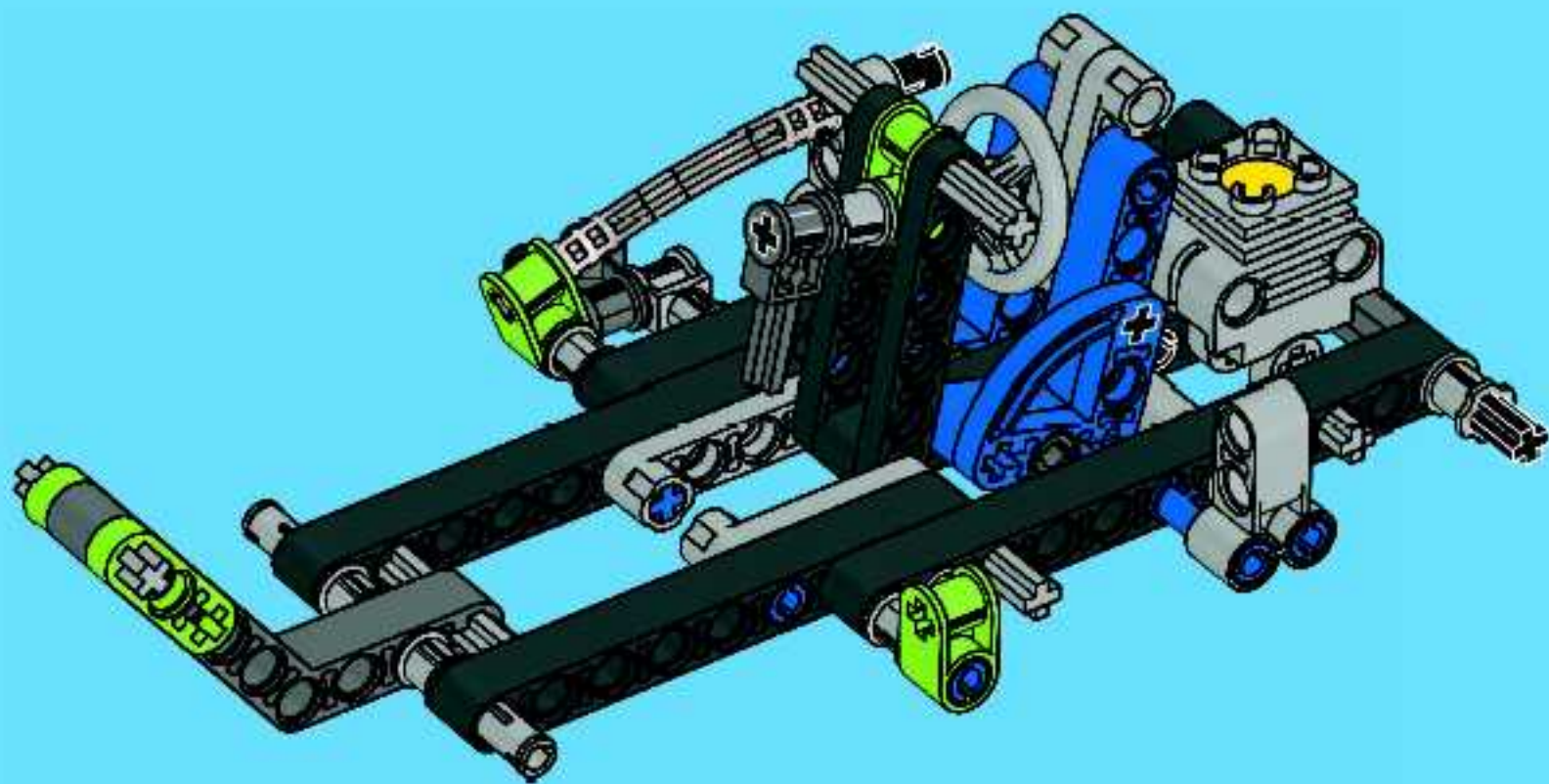



1x



1x



1x



1x

# 26

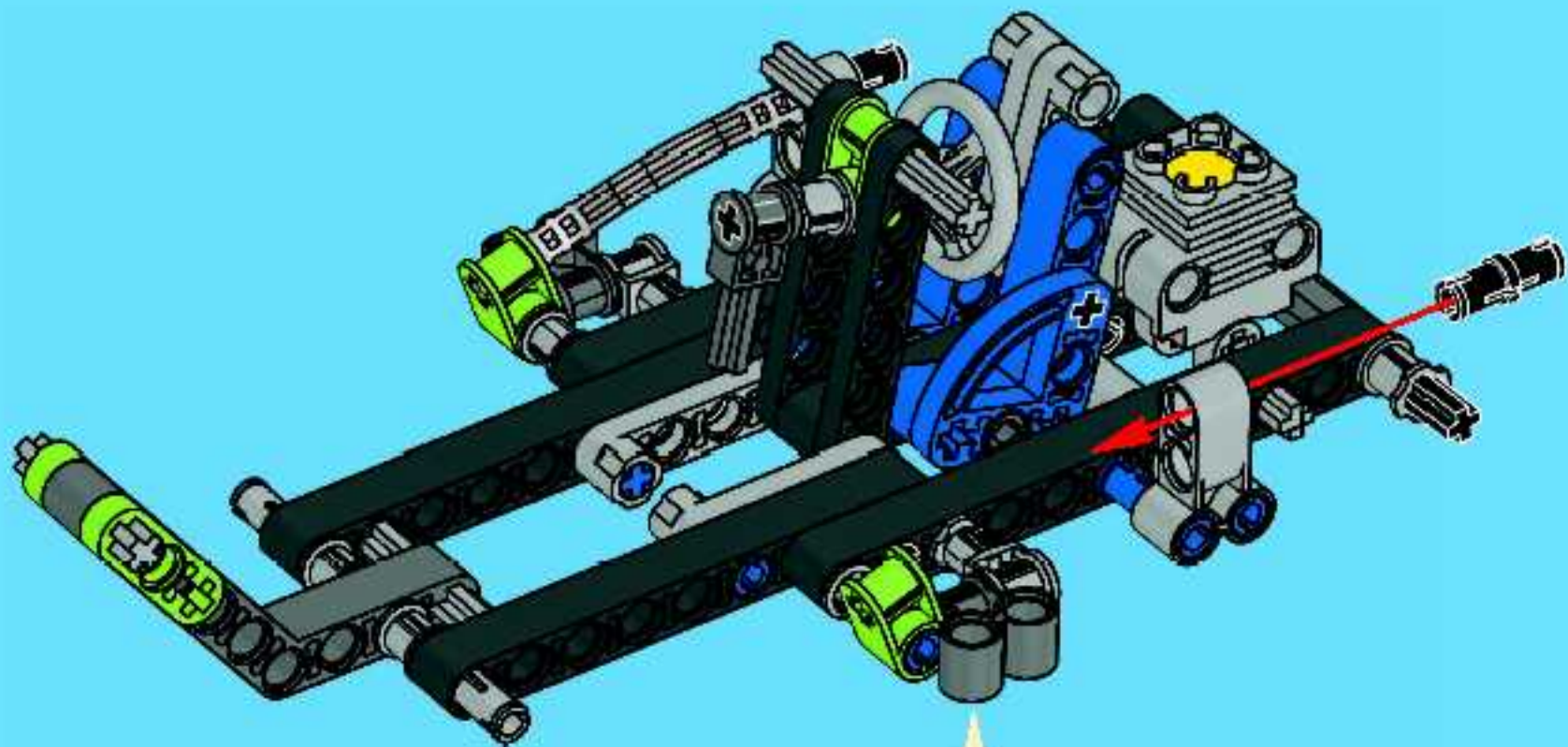

1



2





2x



1x

# 27

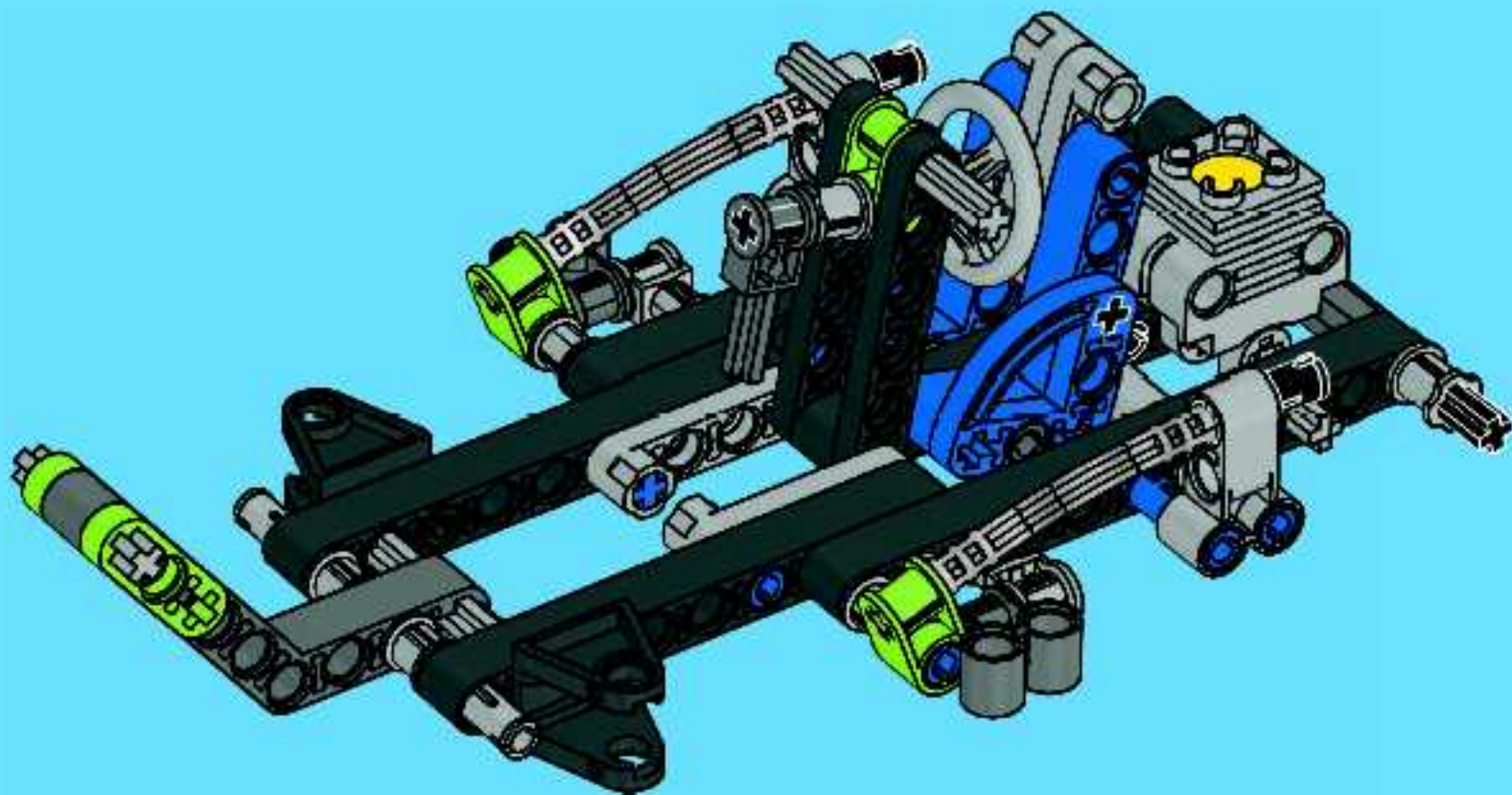





2x

28

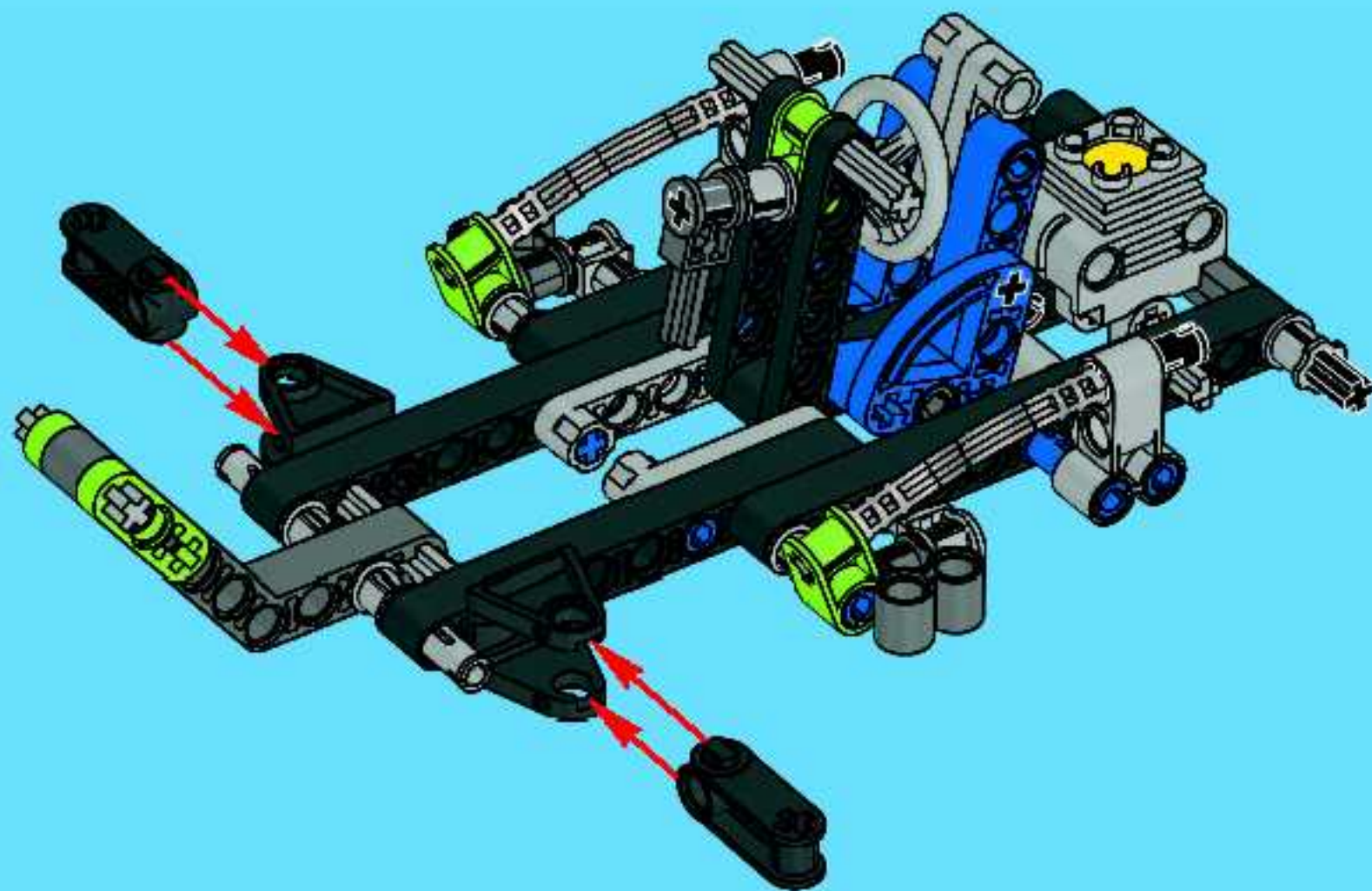



29

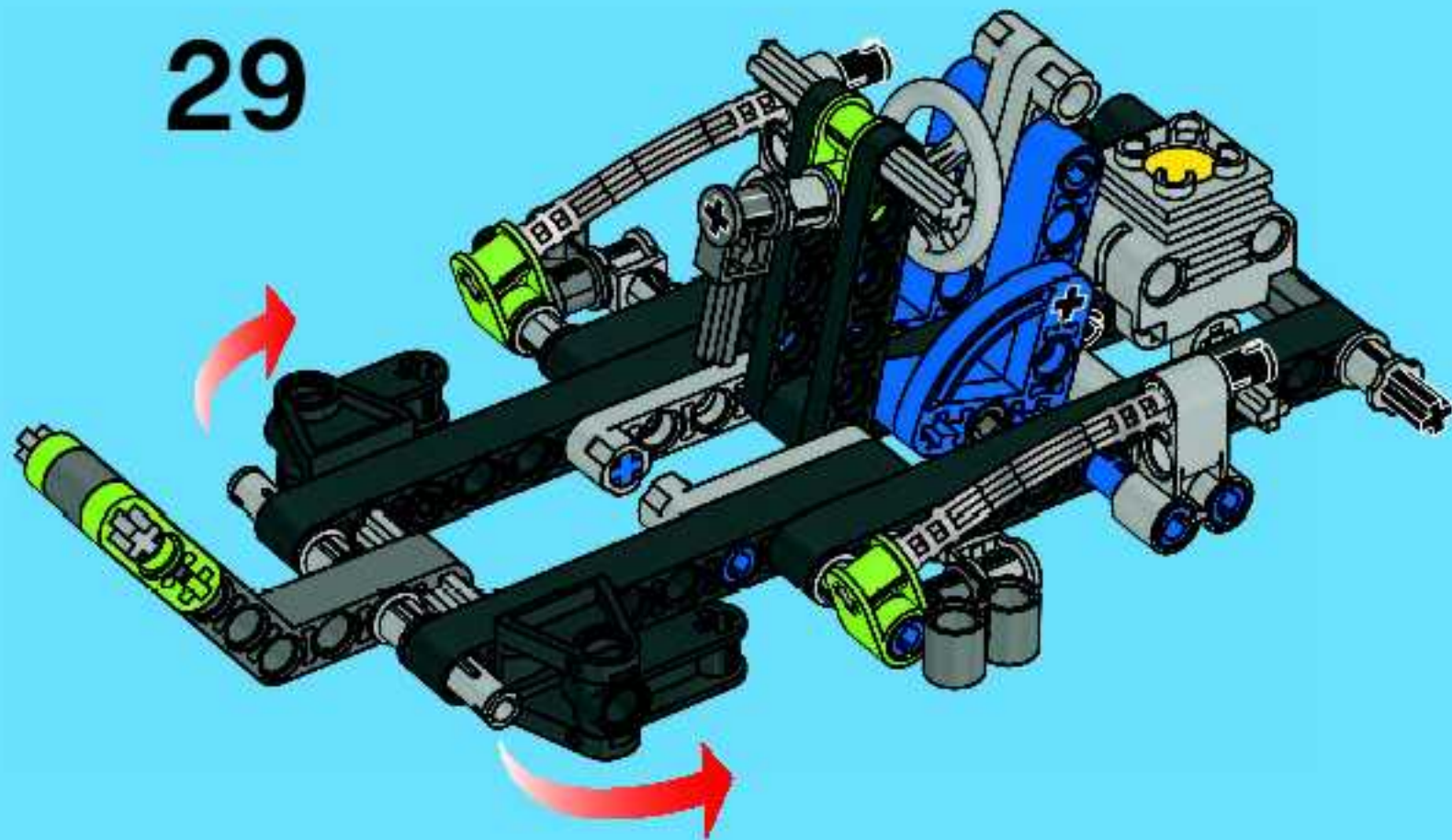



30

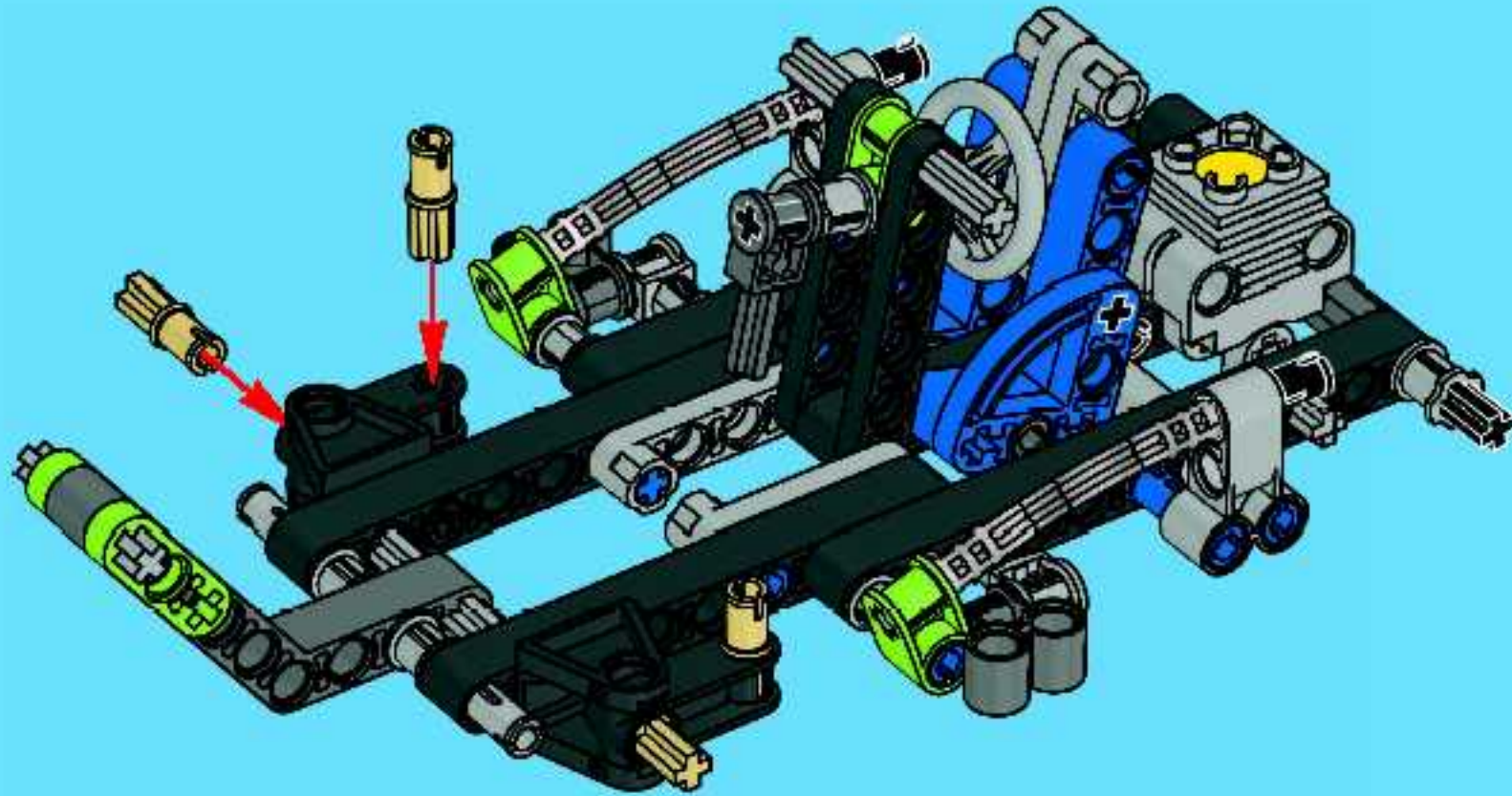



31

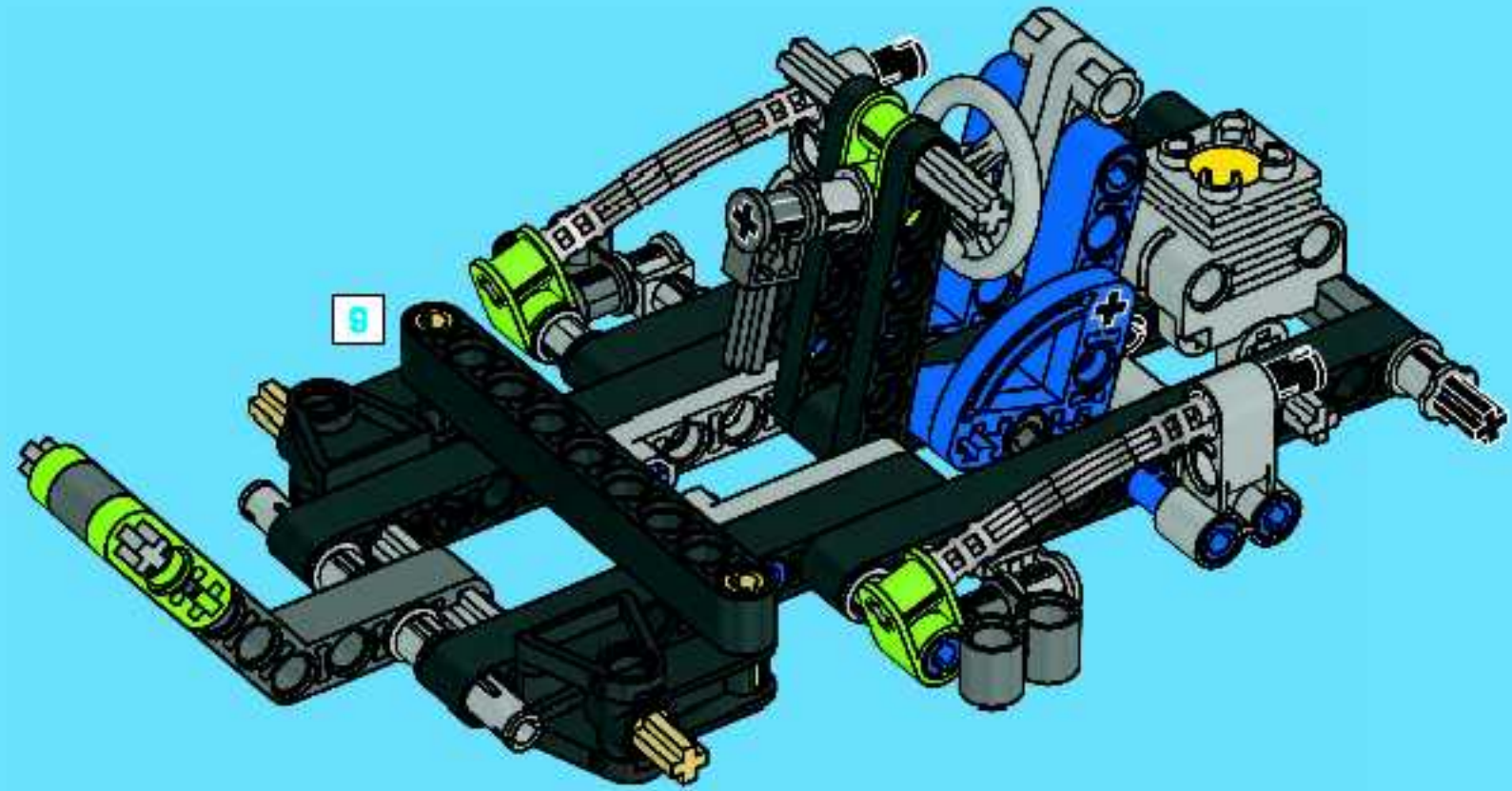





32

1



2



3

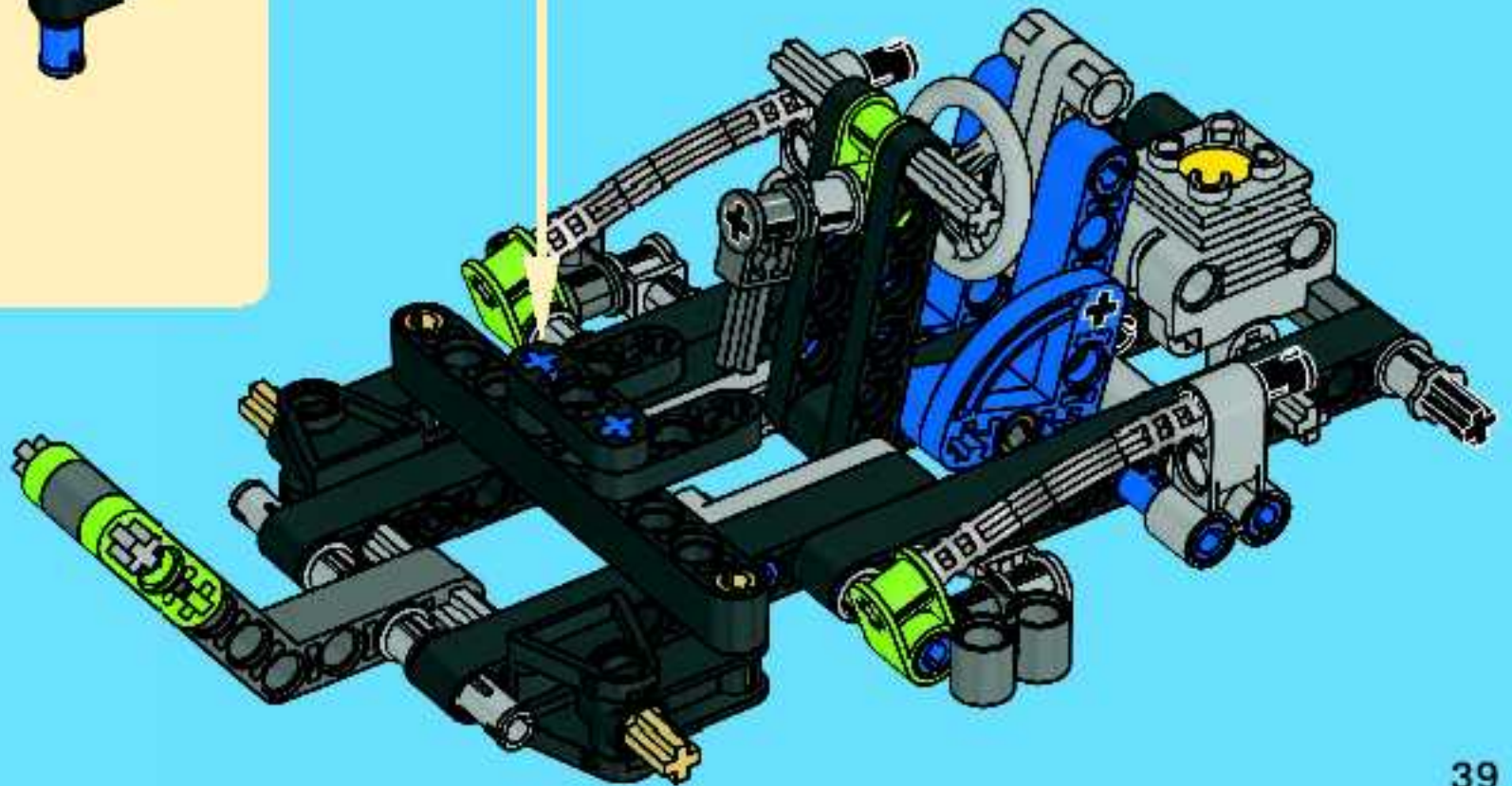



33

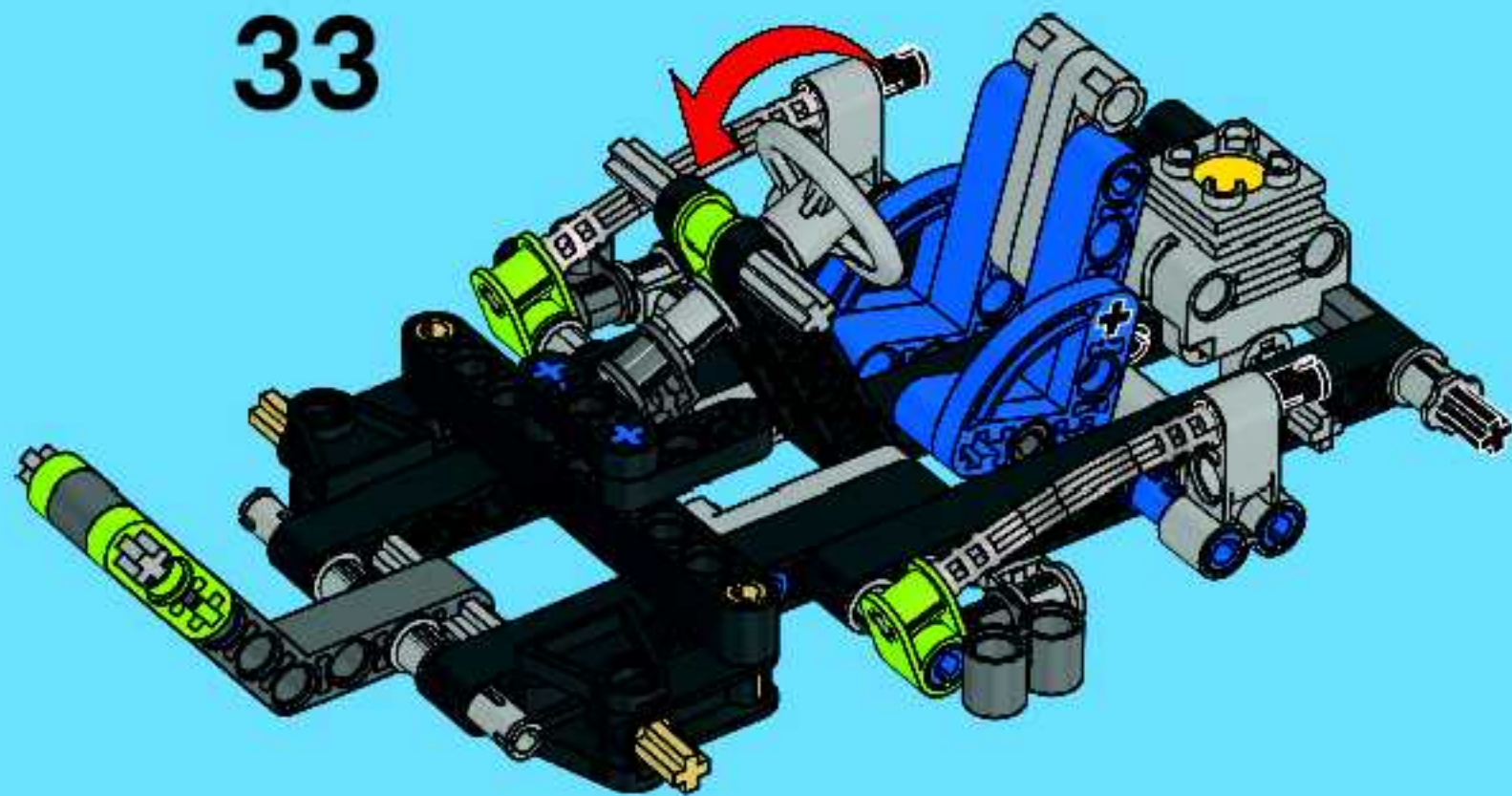

34

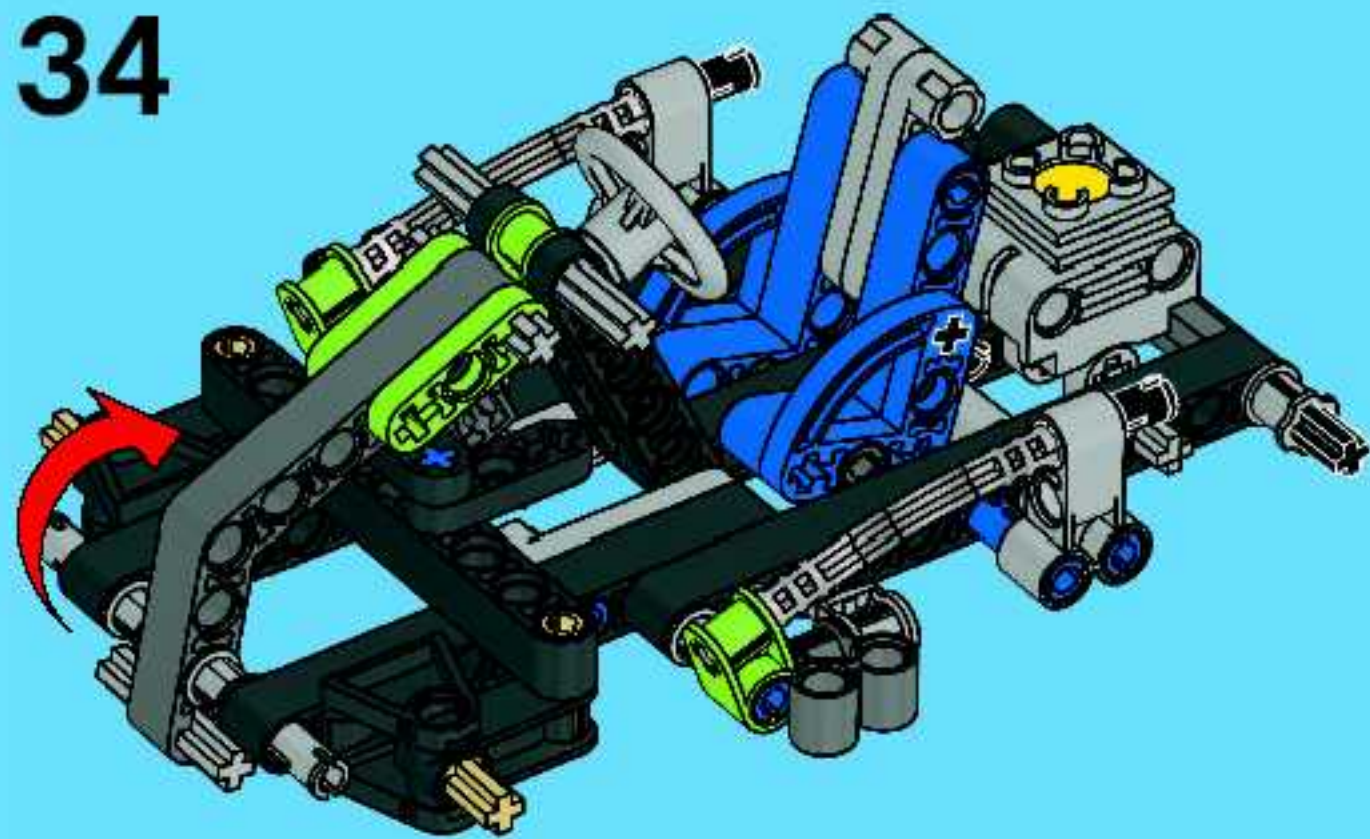



2x

# 35

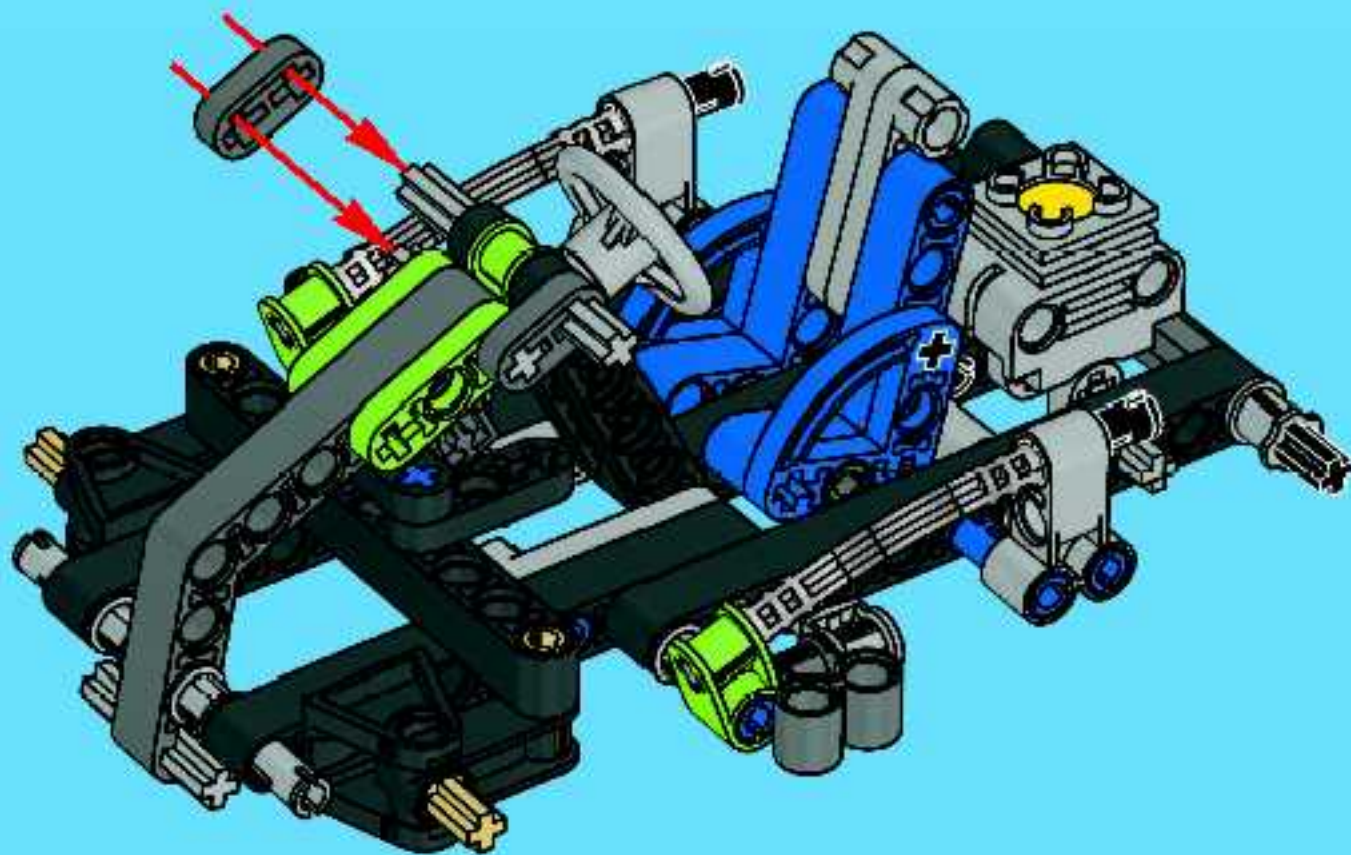





36

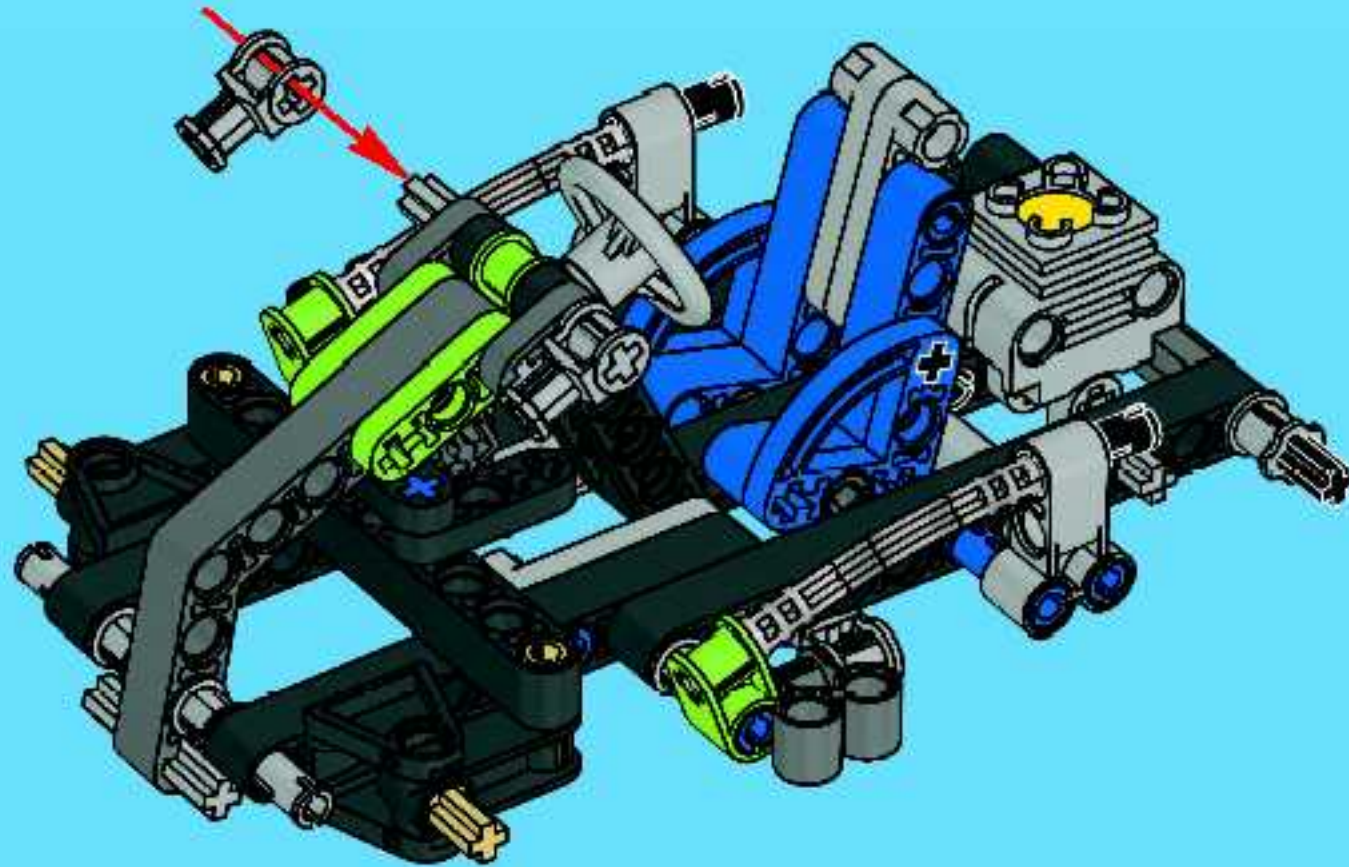





# 37

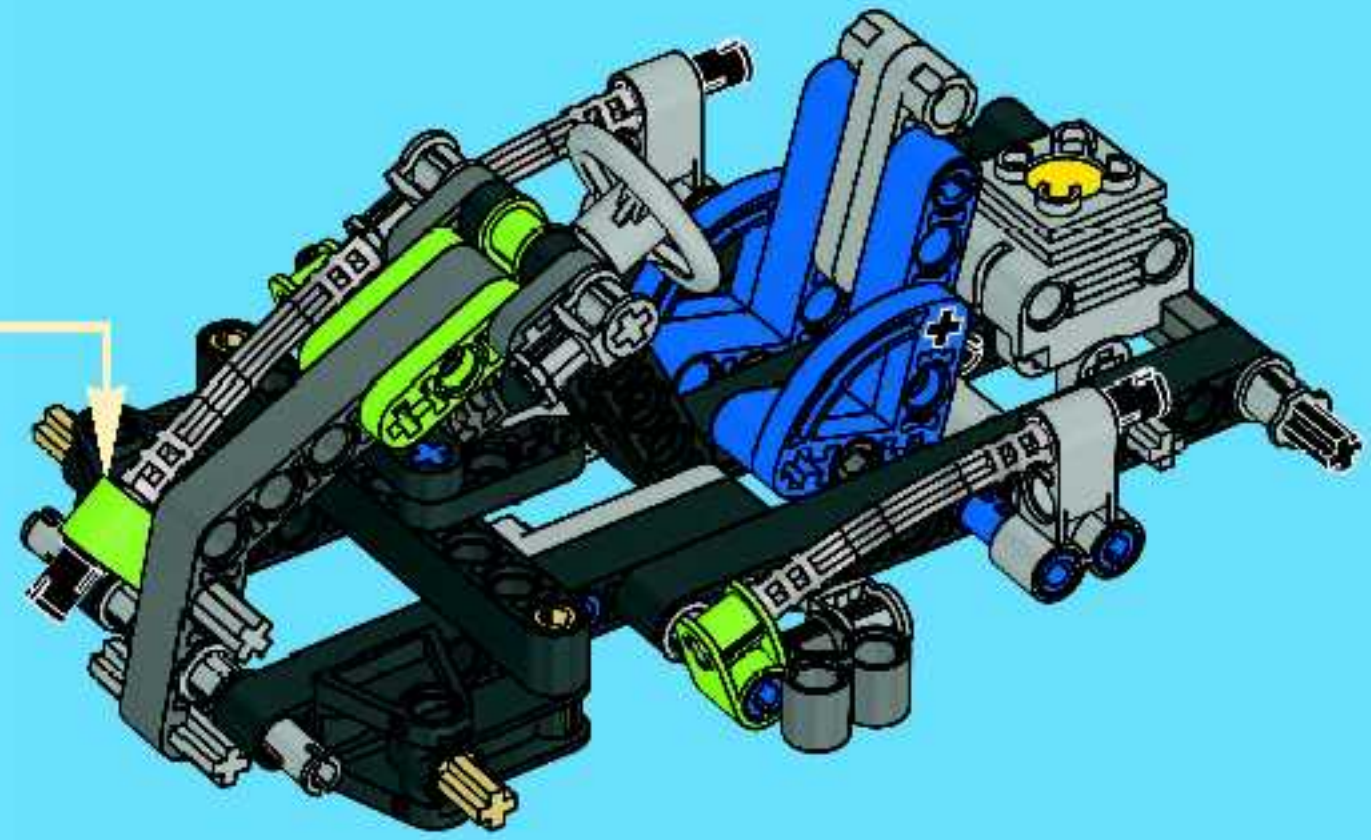
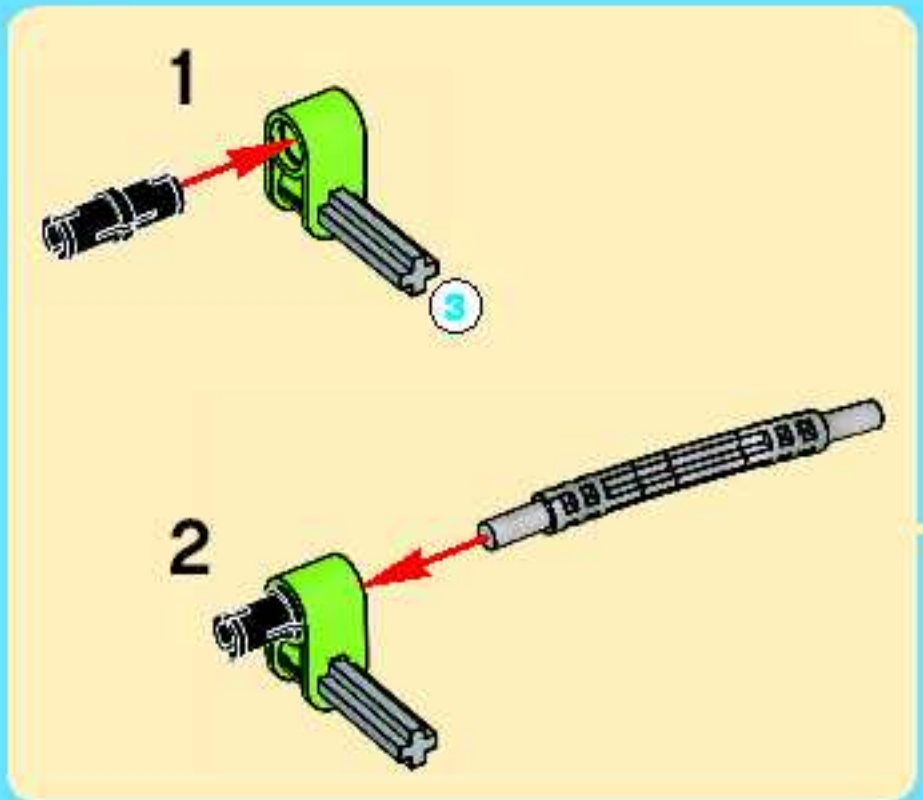



38

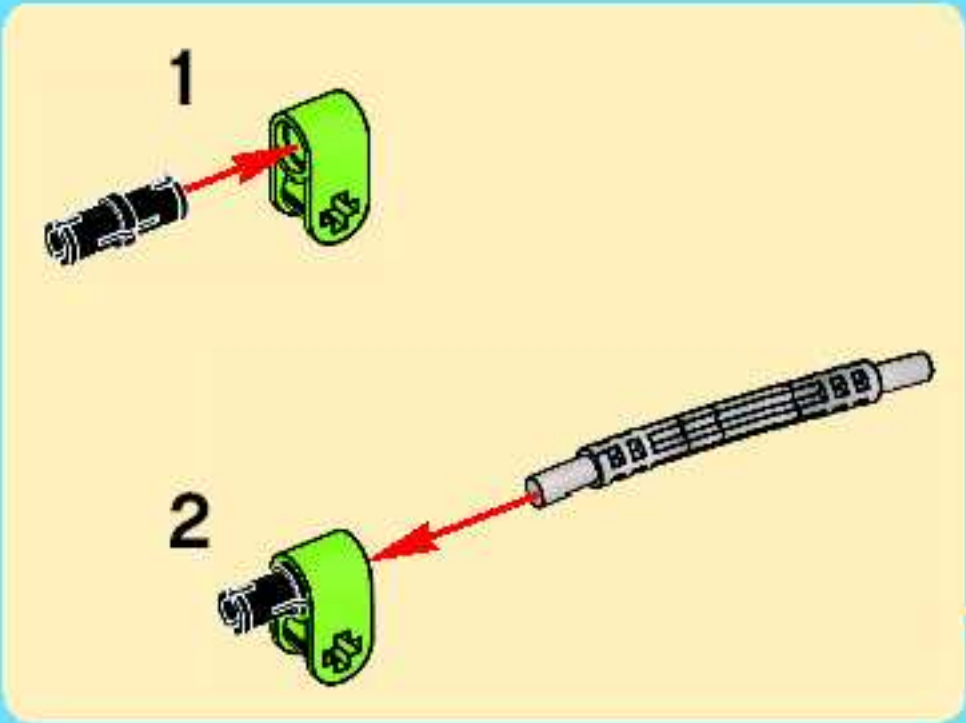
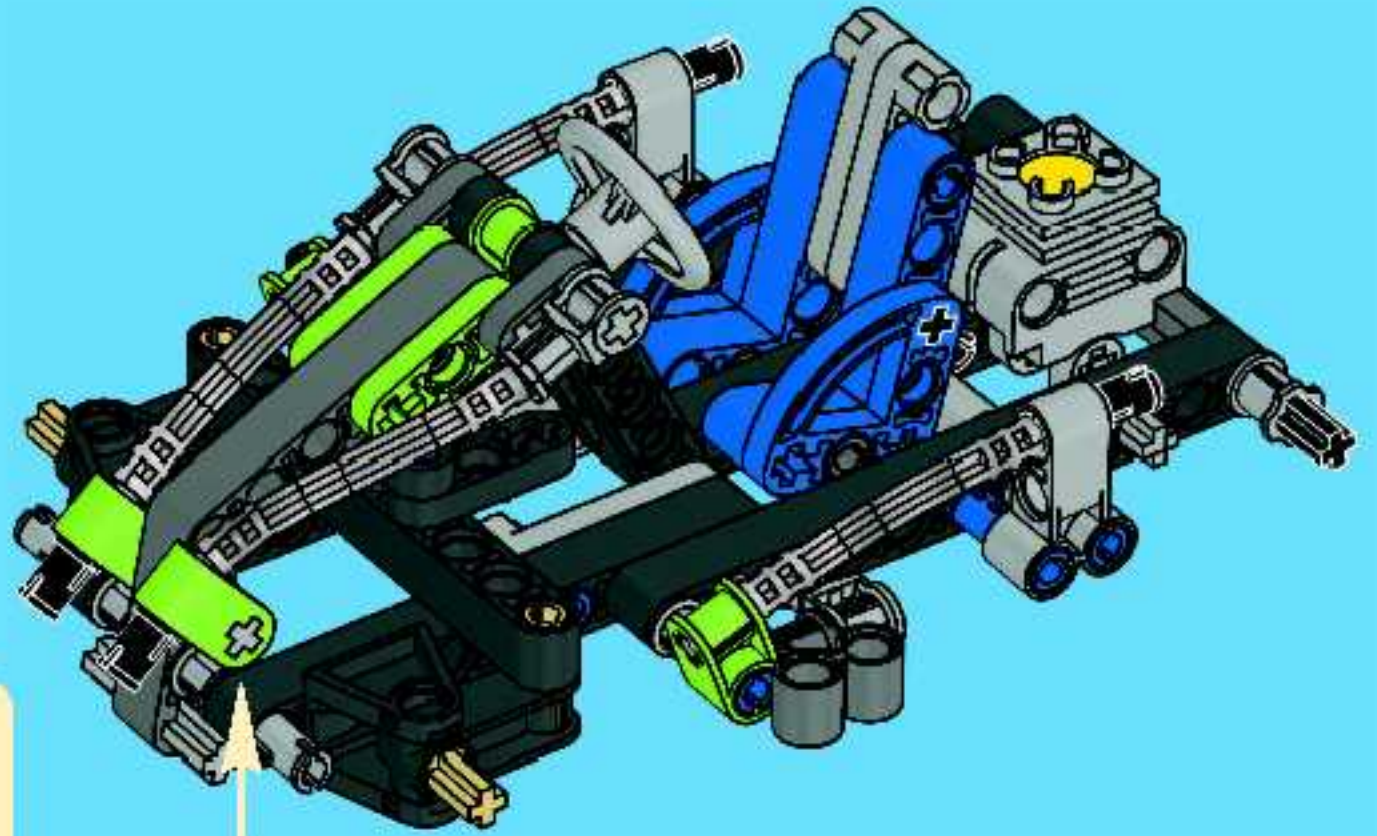





1x

39

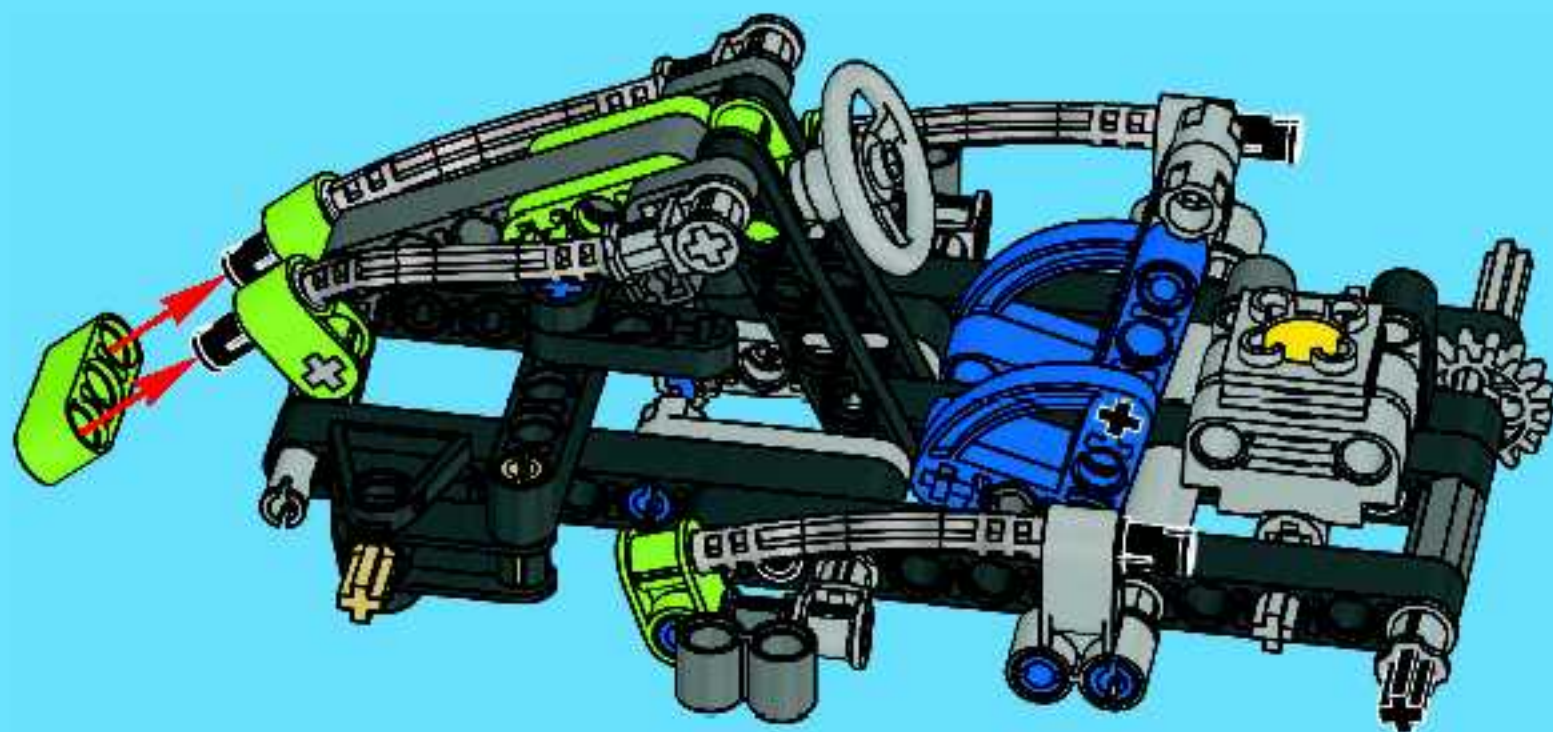



40

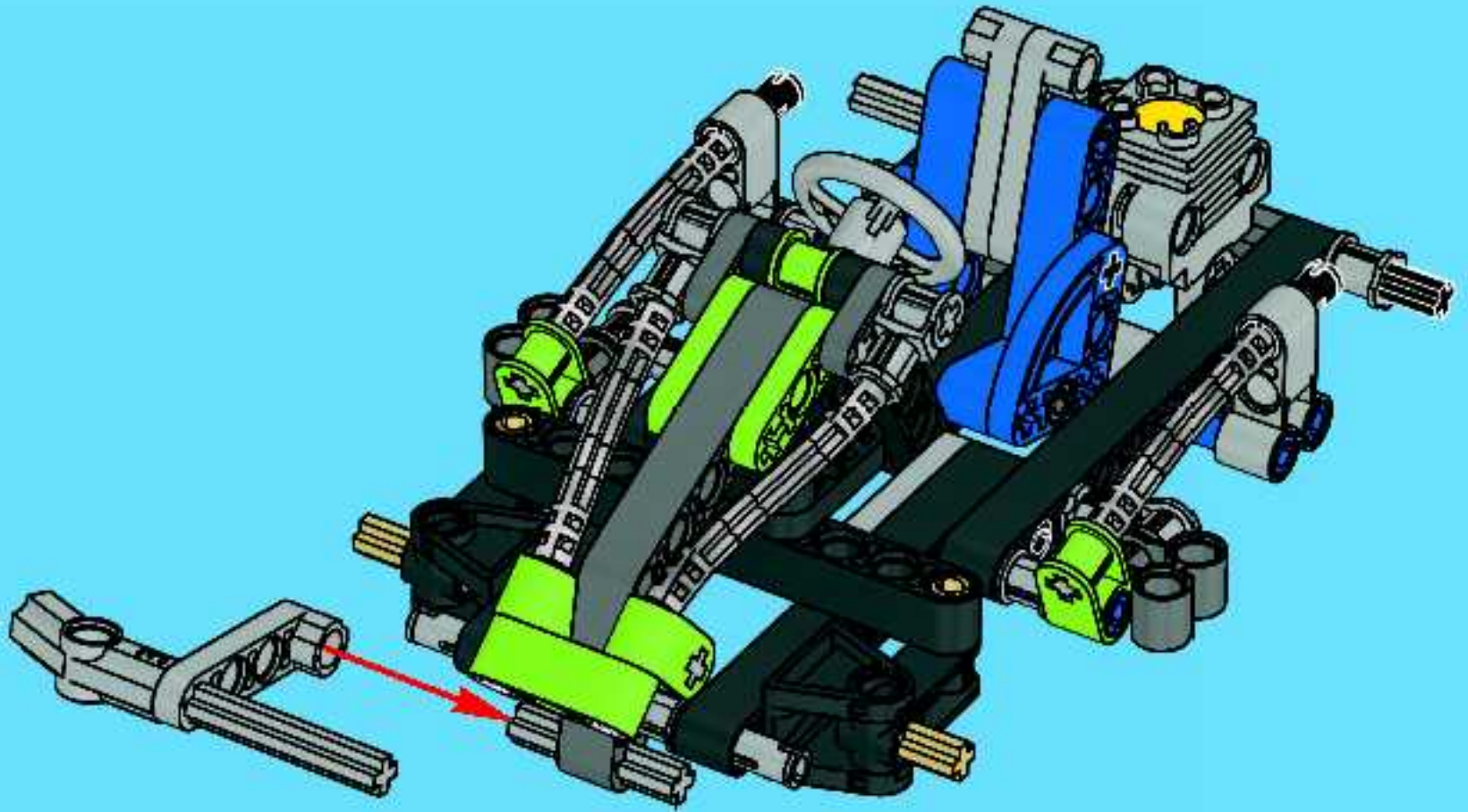
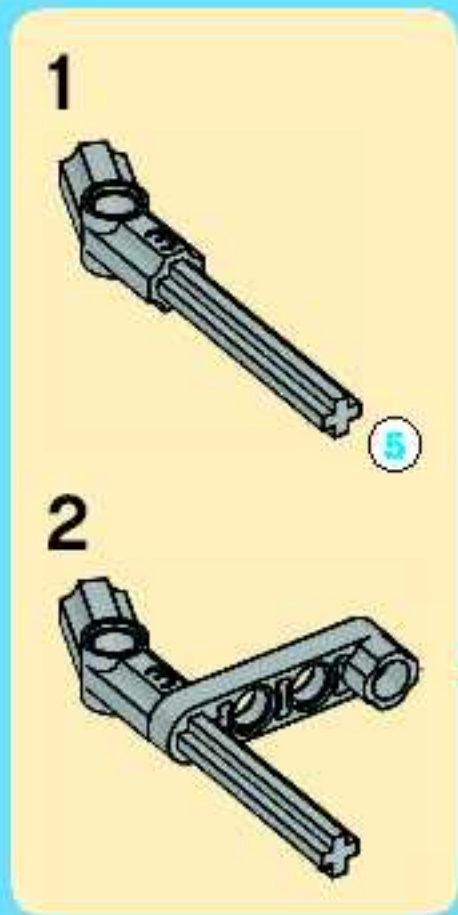





1x

# 41

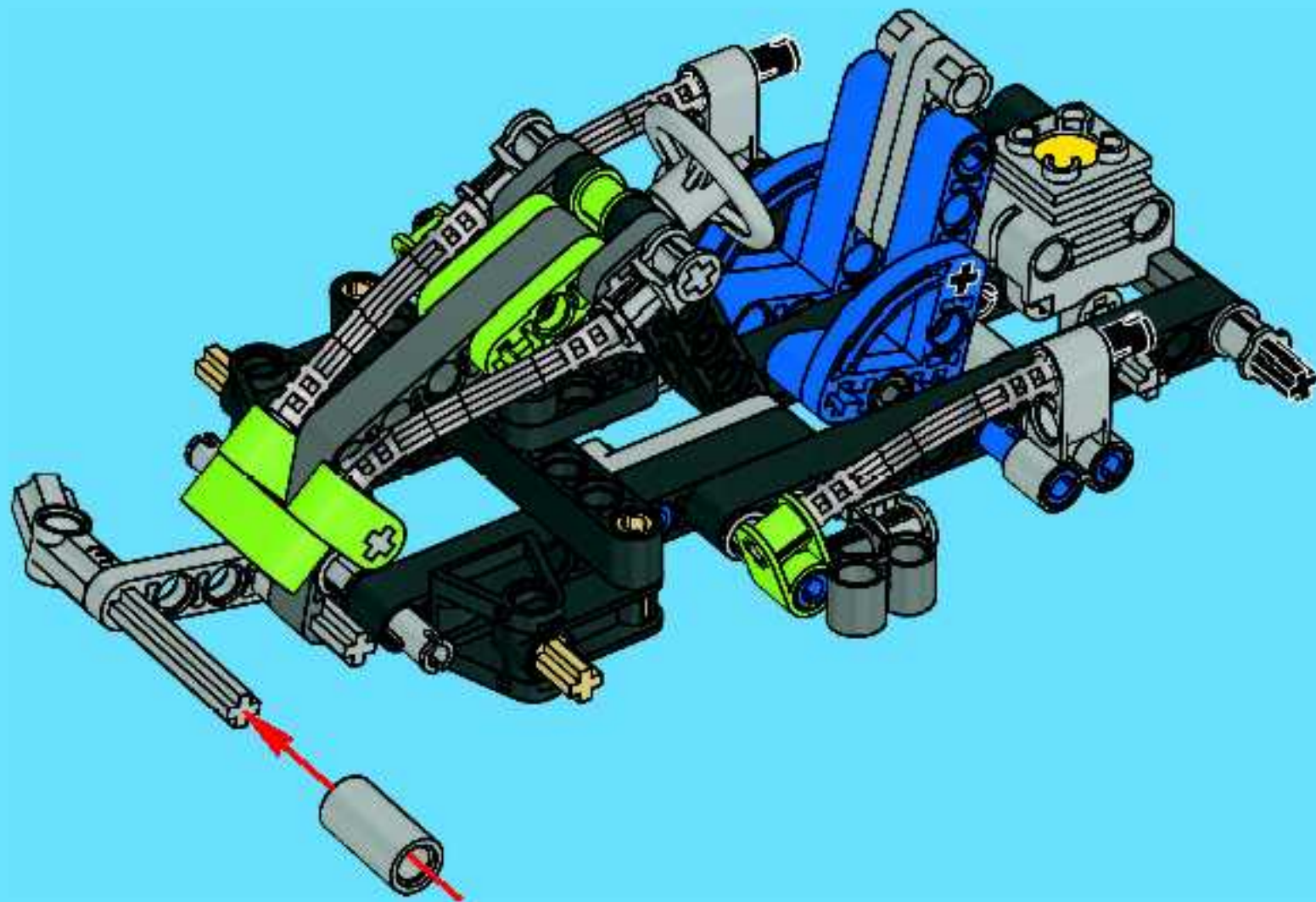



1x

# 42

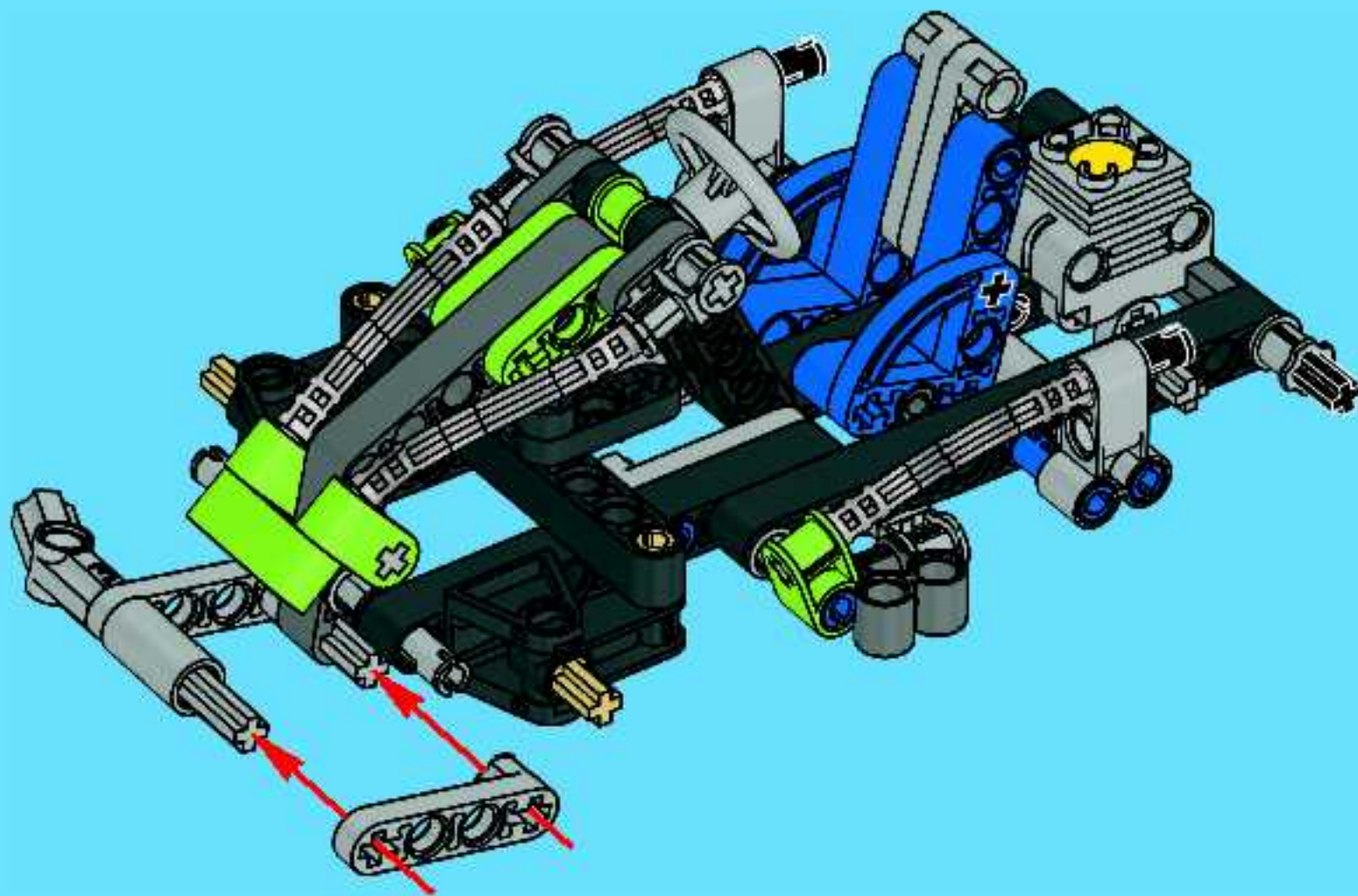





1x



2x

# 43

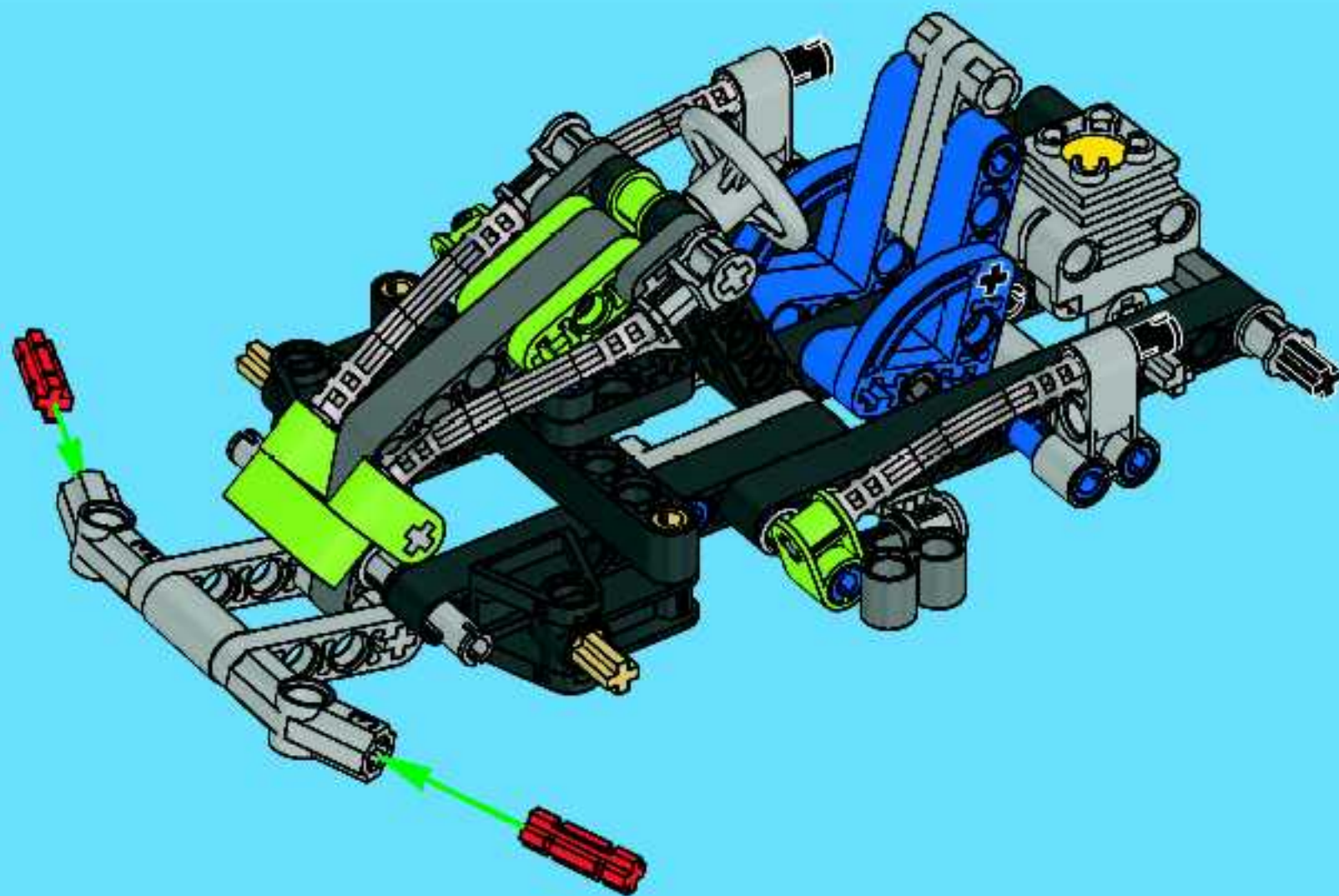



44

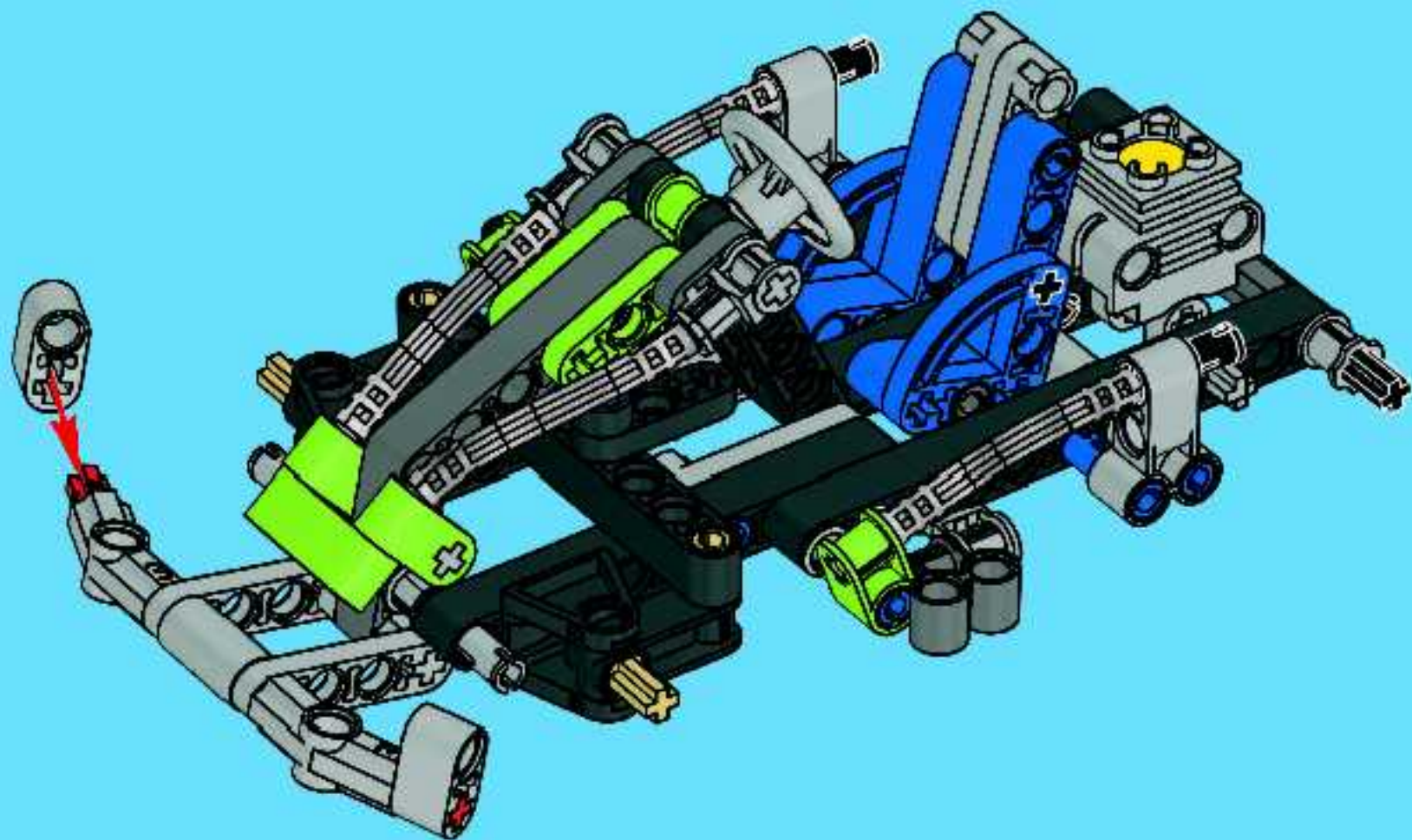



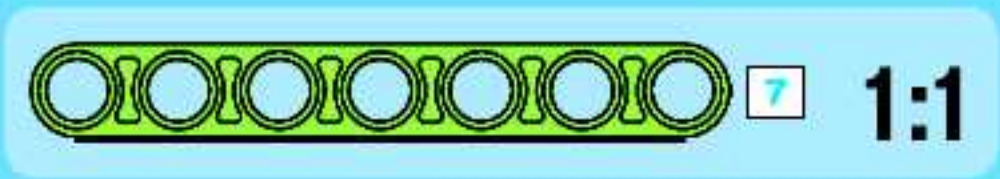
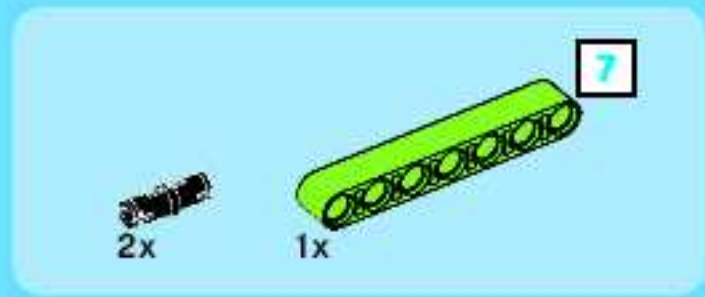

45

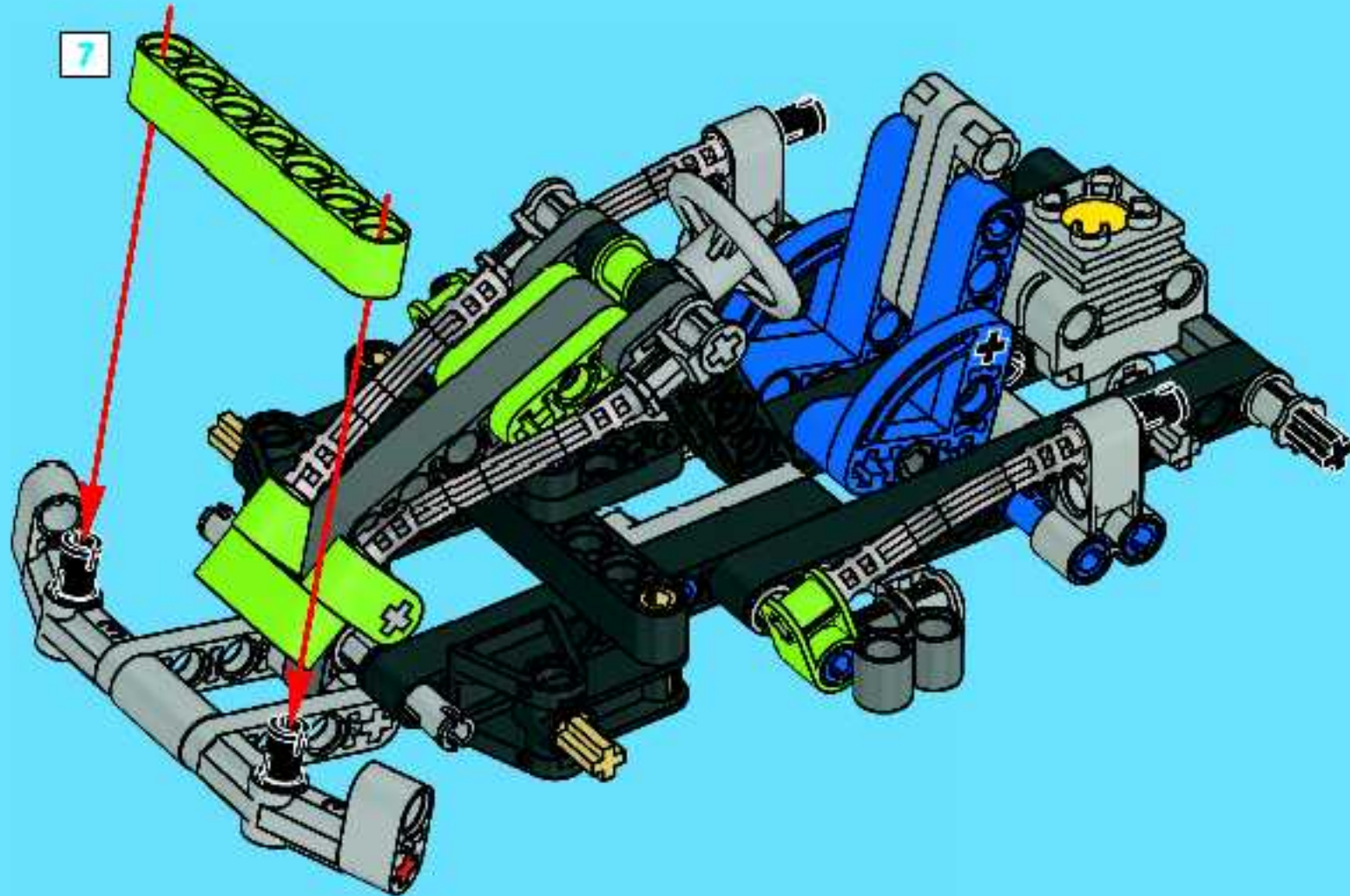

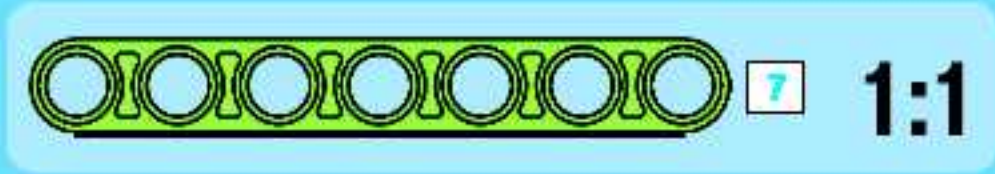
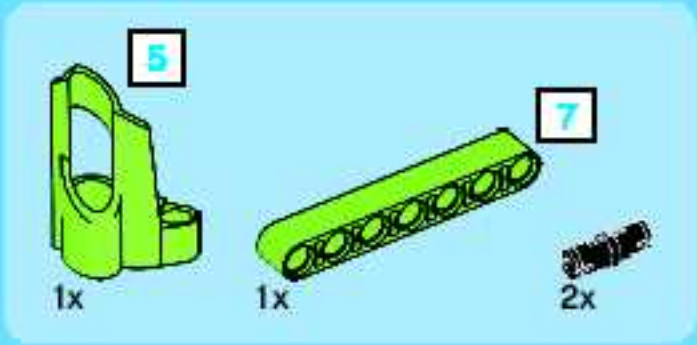

46

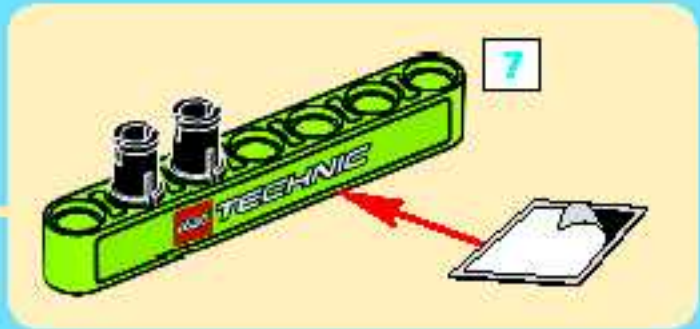
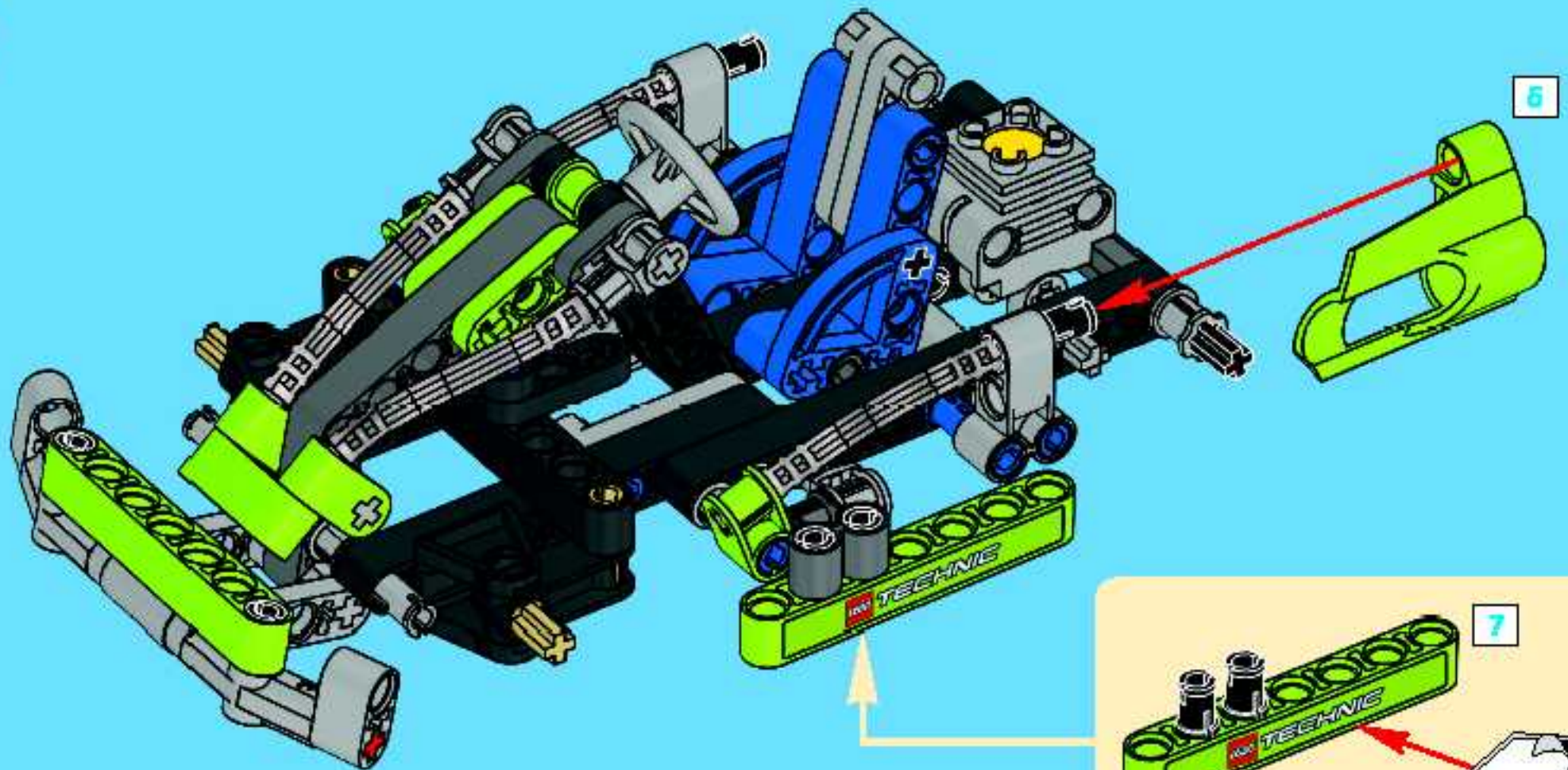





1x



1x



2x

# 47

1

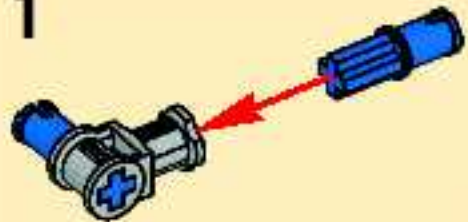

2

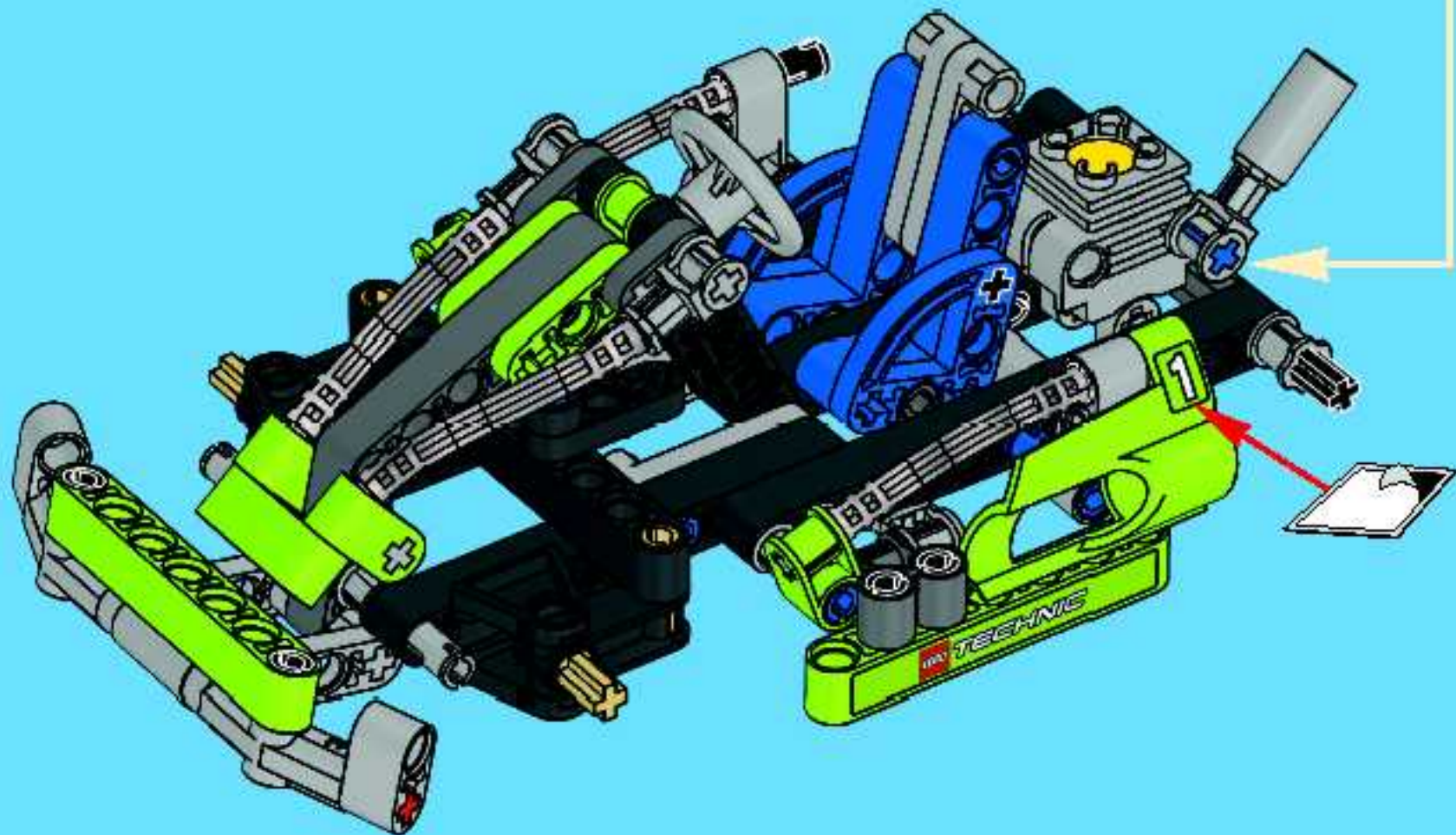
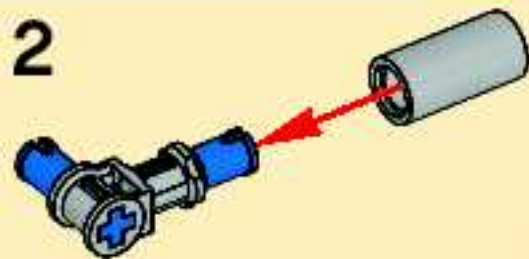



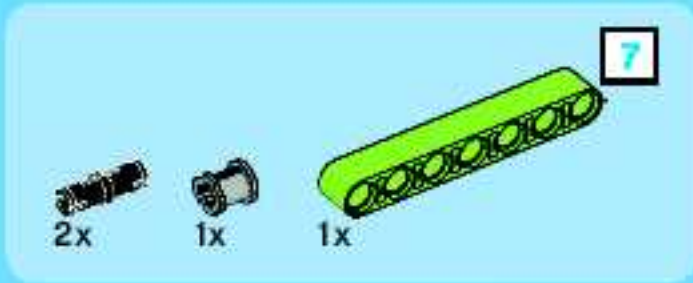

48

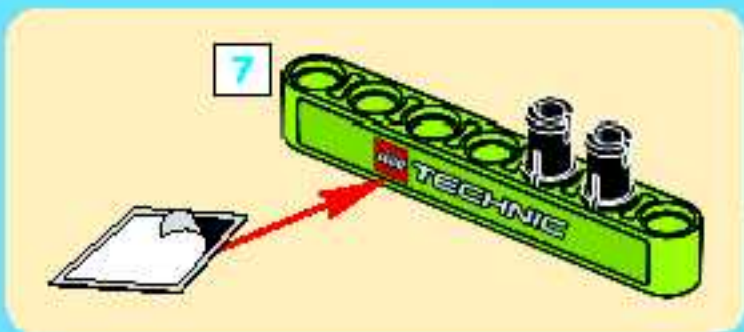
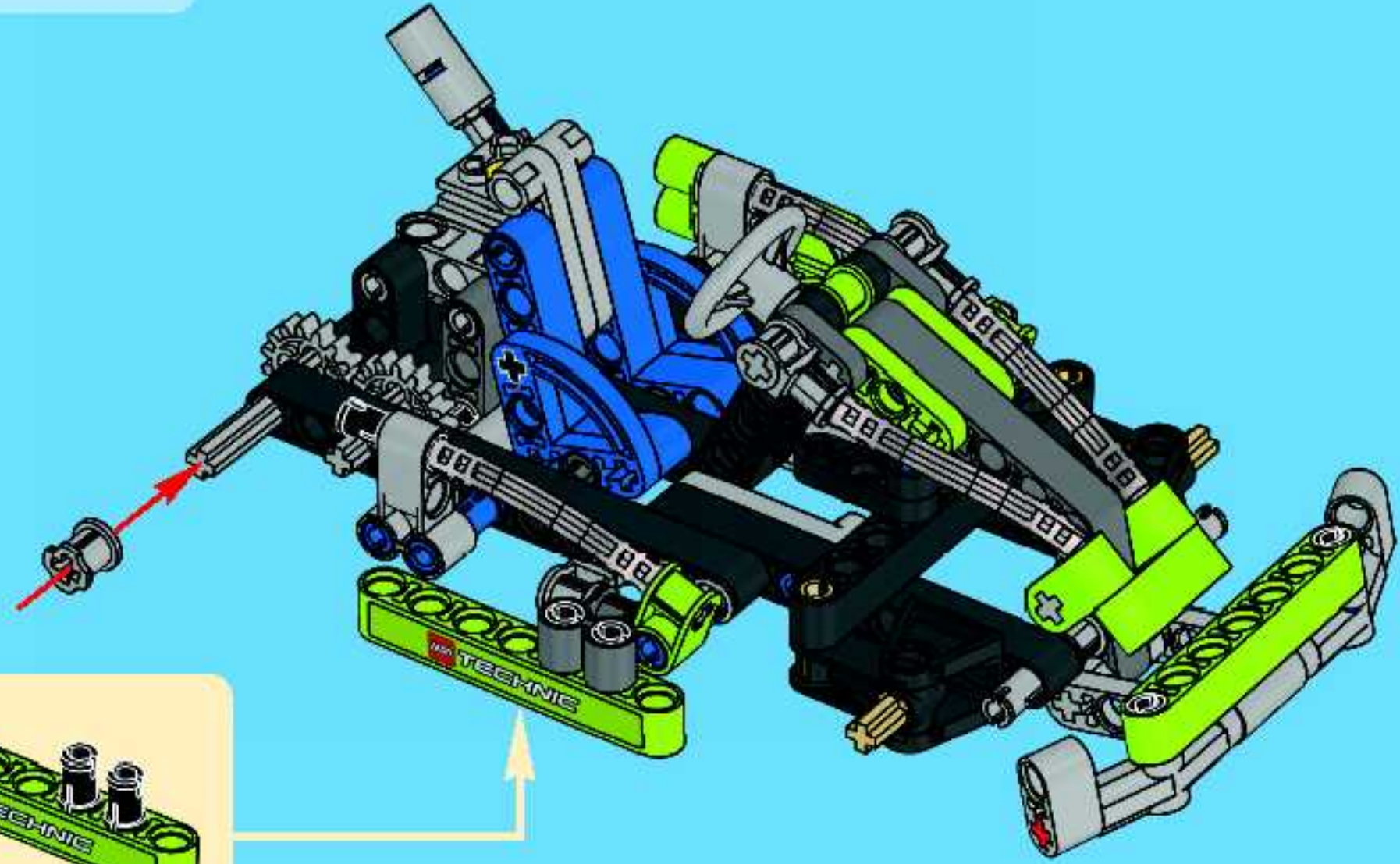



1x

# 49

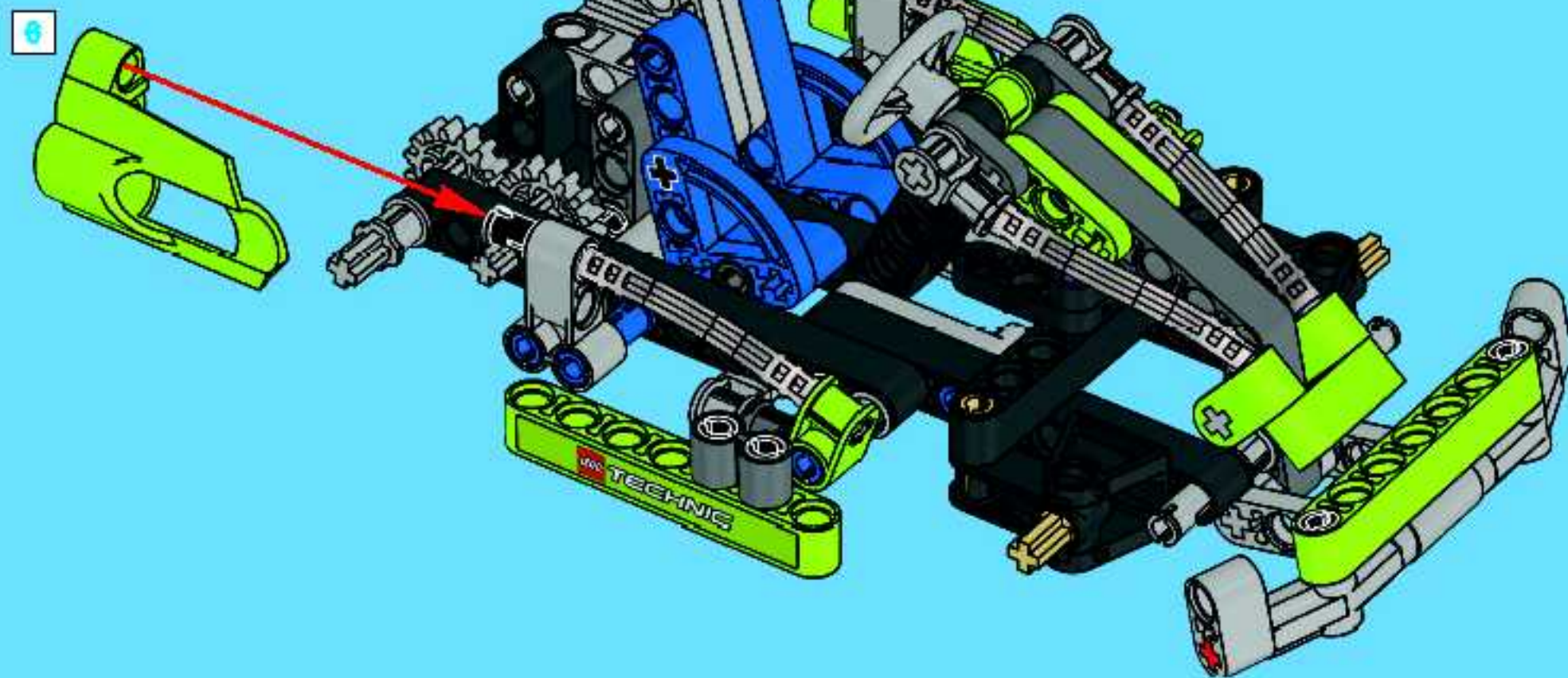





4x



4x

# 50

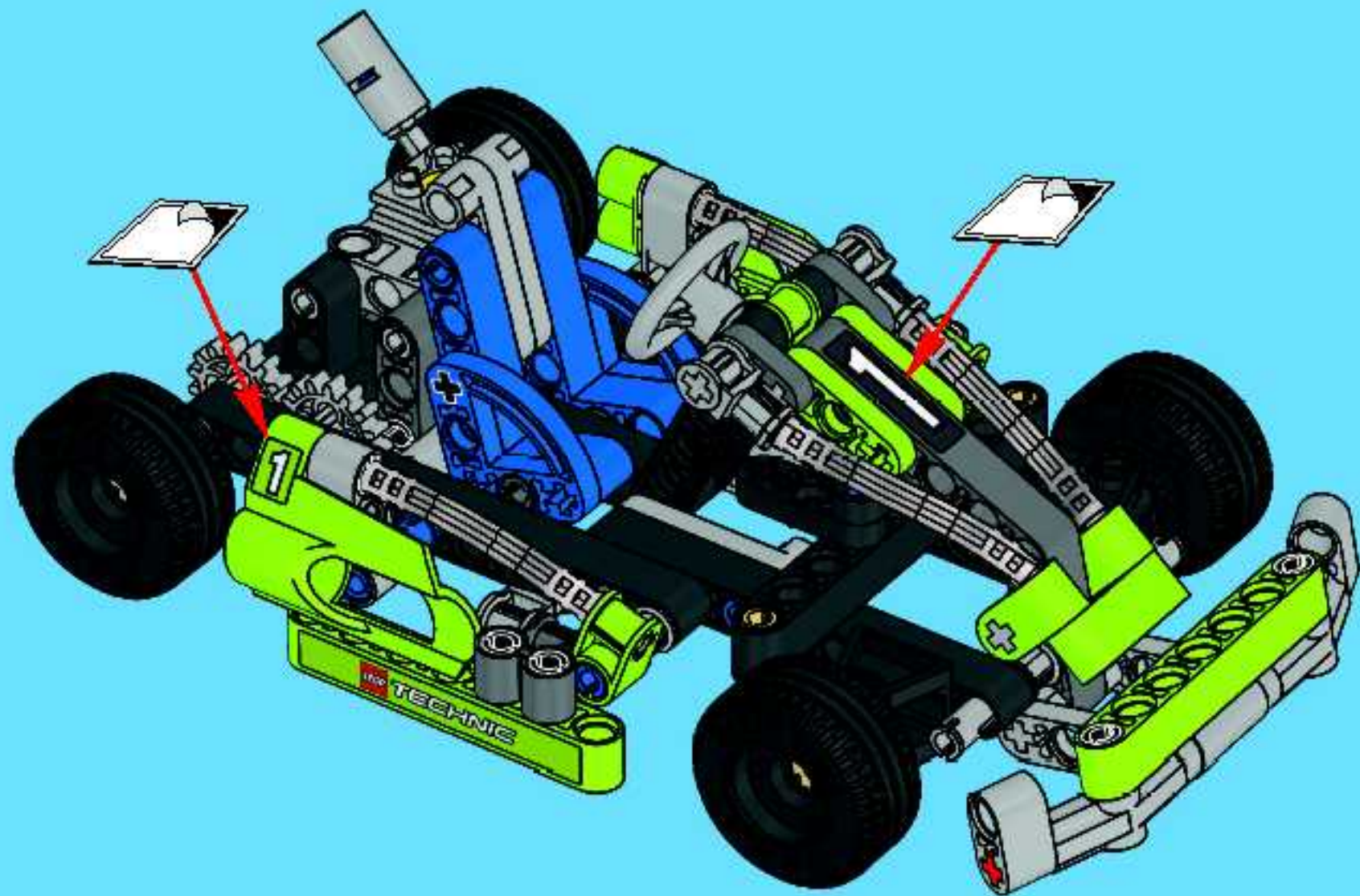





Customer Service

Kundenservice

Service Consommateurs

Servicio Al Consumidor

[www.lego.com/service](http://www.lego.com/service) or dial



00800 5346 5555 :



1-800-422-5346 :





www.lego.com





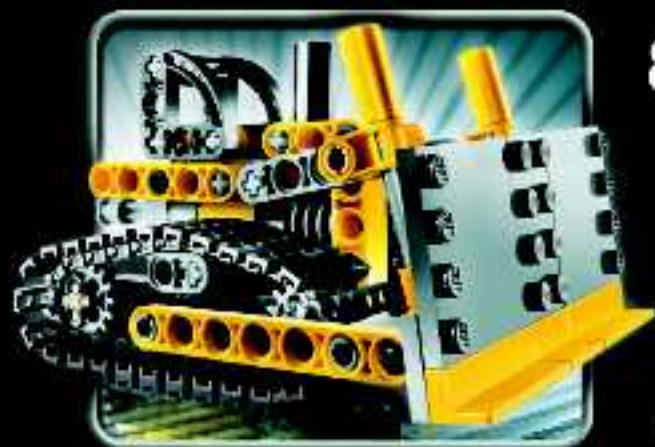

8259

8261



8260



8262



8264

**+ power functions™**



Motor

Battery Box



**FREE! GRATIS! GRATUIT!**



**club**  
MAGAZINE™

**www.LEGOclub.com**



**00800 5346 5555\***        



**1-866-534-6258 • 1-877-518-5346**

US & Canada only

Canada seulement

\* Free phone. Mobile charges may apply. \*\* Numéro sans frais, les frais peuvent s'appliquer avec les téléphones cellulaires. \*\*\* GelMötenFrei, Kosten für Anrufe aus Mobilfunknetzen können anfallen. \*\*\*\* Gratis telefonnummer van vaste lijn. \*\*\*\*\* Det er ett gratis nummer när du ringer Pro Fastline. \*\*\*\*\* Det är gratis, när du ringer från en Post-tel. linje.



VISIT THE WORLD'S  
BIGGEST LEGO® SHOP!

**www.LEGOshop.com**









## WIN LEGO® PRODUCTS

Fill out a survey and you might WIN a cool LEGO product  
NO PURCHASE NECESSARY

Open to all residents where not prohibited

Go to [www.nielsen.am.dk/LEGO](http://www.nielsen.am.dk/LEGO) to fill out a survey for a chance to win a LEGO product.

## WIN LEGO® PRODUCTEN

Vul een enquêteformulier in en maak kans op een cool LEGO® product!

Kopen niet nodig

Iedereen uit landen waar geen enquêteverbod geldt mag deelnemen.

Ga naar [www.nielsen.nl/dk/LEGO](http://www.nielsen.nl/dk/LEGO), vul een enquêteformulier in en maak kans op een LEGO product.

## GEWINNE LEGO® PRODUKTE

Nimm an der Umfrage teil und GEWINNE ein tolles LEGO® Produkt!

Die Teilnahme am Gewinnspiel führt zu keinerlei Kaufverpflichtungen

Teilnahme in allen nicht ausgeschlossenen Ländern möglich

Wir verlosen unter allen Teilnehmern der Umfrage auf

[www.nielsen.am.dk/LEGO](http://www.nielsen.am.dk/LEGO) LEGO Produkte.

## GAGNE DES PRODUITS LEGO®

Réponds à un questionnaire et tu pourrais GAGNER un produit LEGO® très cool !

Aucune obligation d'achat.

Couvert à tous les résidents des pays autorisés.

Visite [www.nielsen.am.dk/LEGO](http://www.nielsen.am.dk/LEGO) pour répondre à un questionnaire et avoir une chance de gagner un produit LEGO.

## レゴ®製品を「当てよう」

アンケートに記入して、カッコいいレゴ®製品を当てよう！

お買い上げの必要はありません。

禁止されていない限り、すべての皆様にご利用いただけます。

[www.nielsen.am.dk/LEGO](http://www.nielsen.am.dk/LEGO)にアクセスして、アンケートにご記入ください。当選者にはレゴ製品を差し上げます。







# TECHNIC

8256





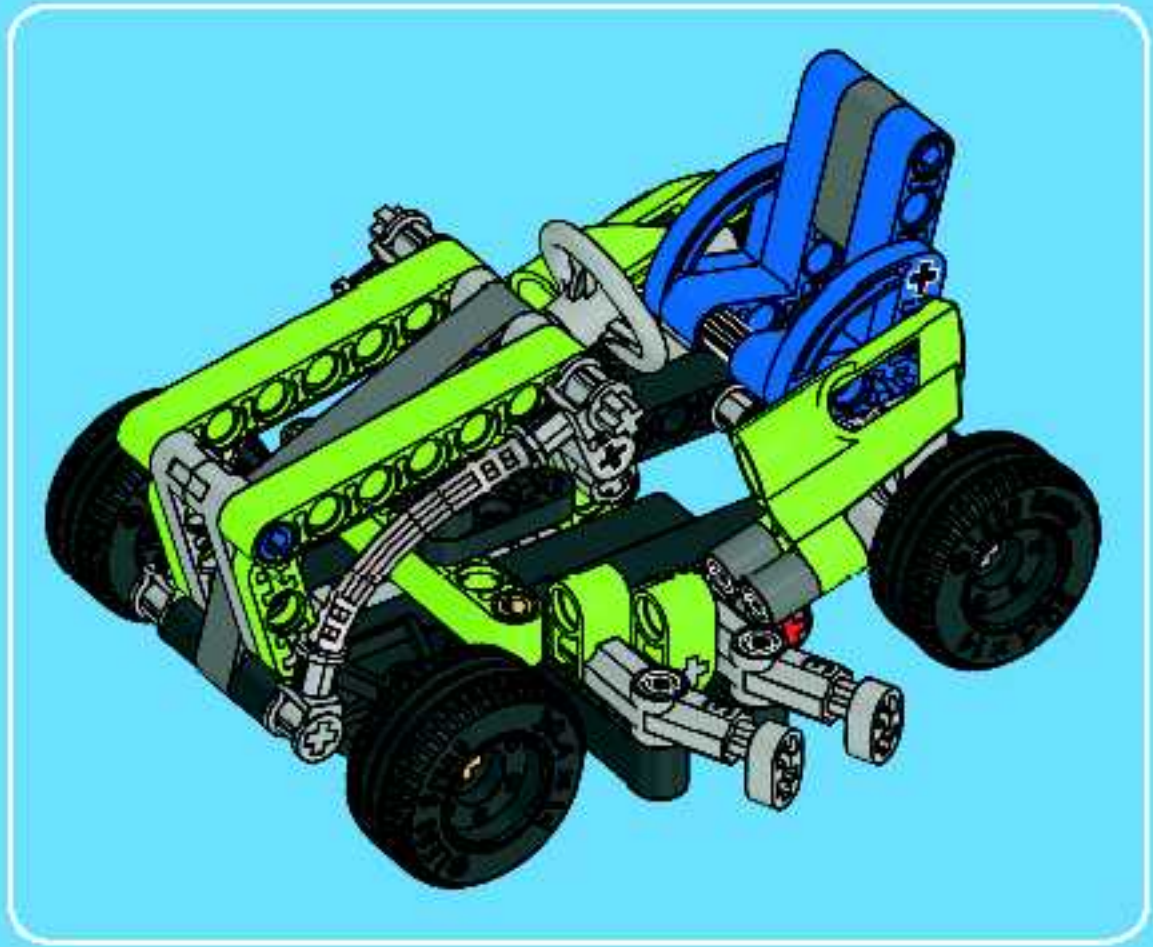

1

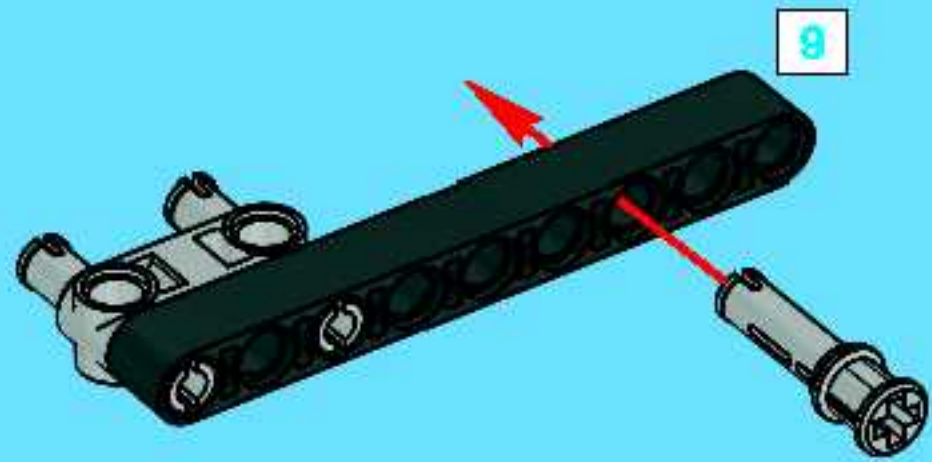



1x

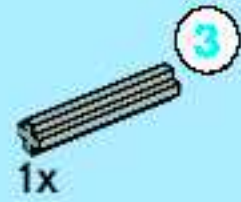

1x

# 2

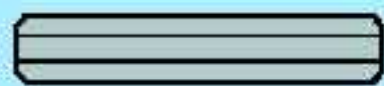
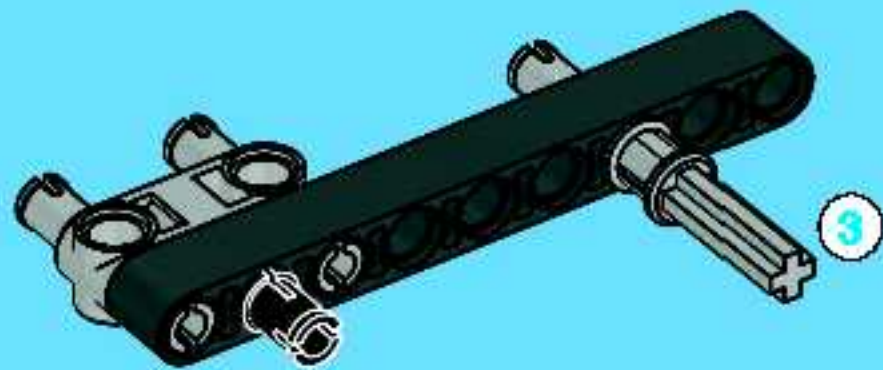

3

# 1:1



1x



2x



1x



1x

# 3

1

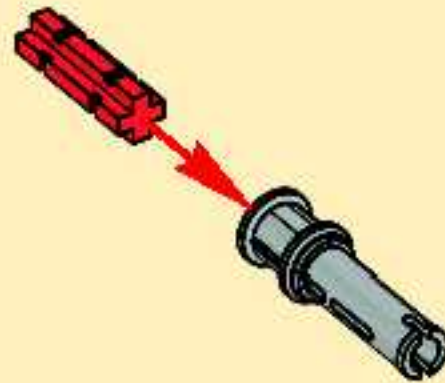

2



3

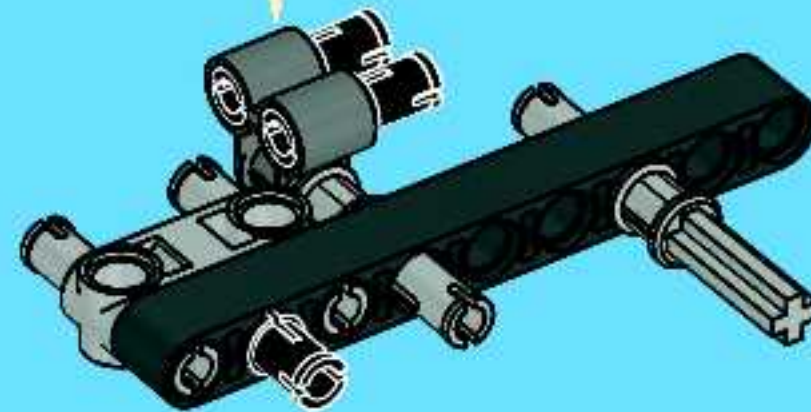
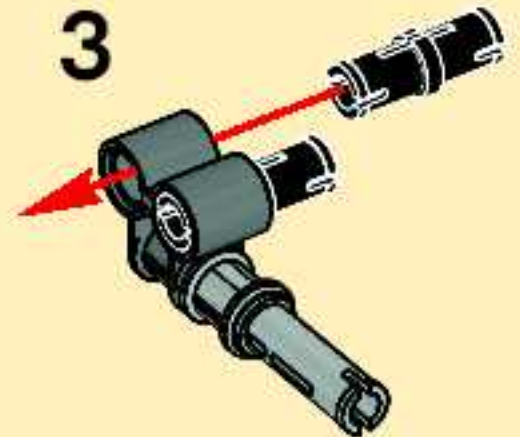



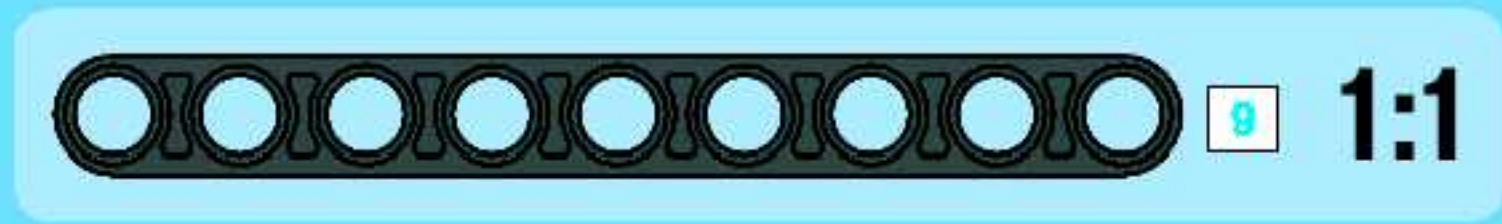

4

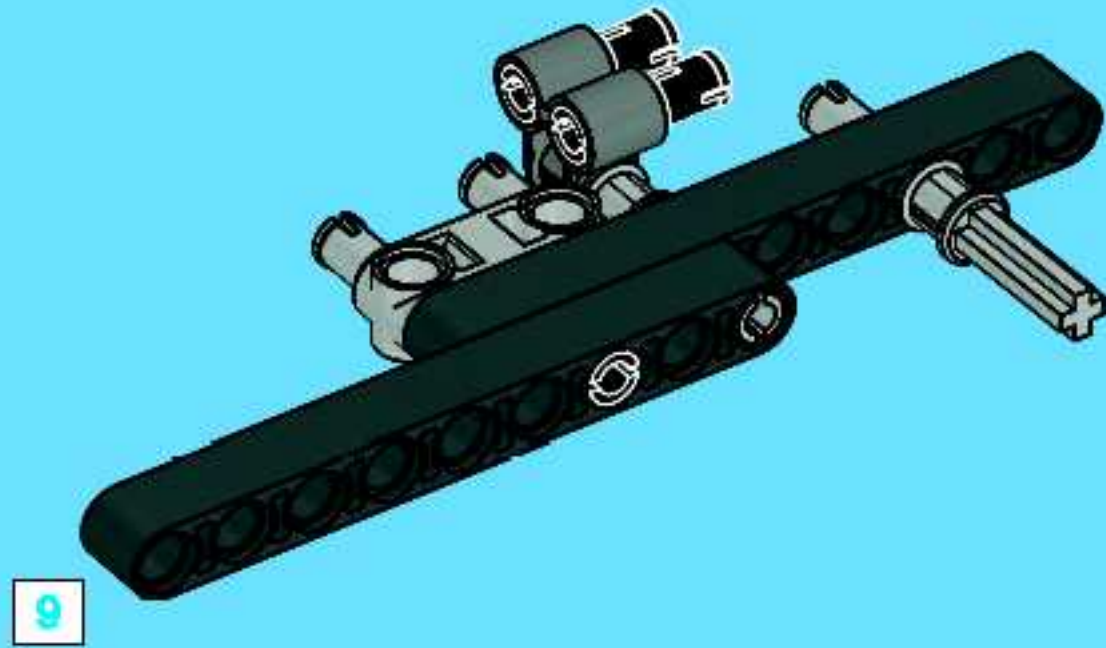

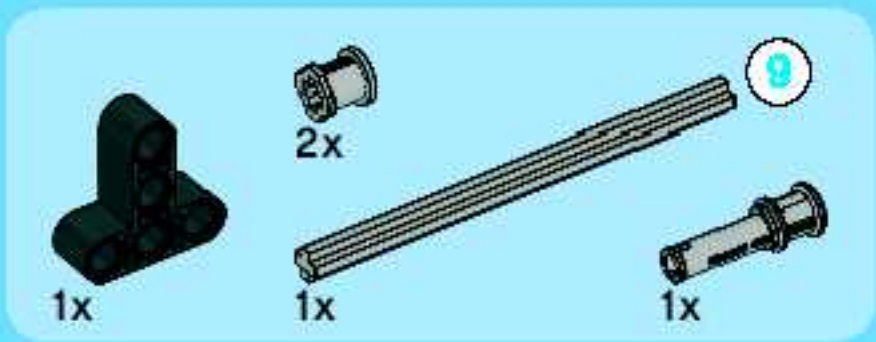

5

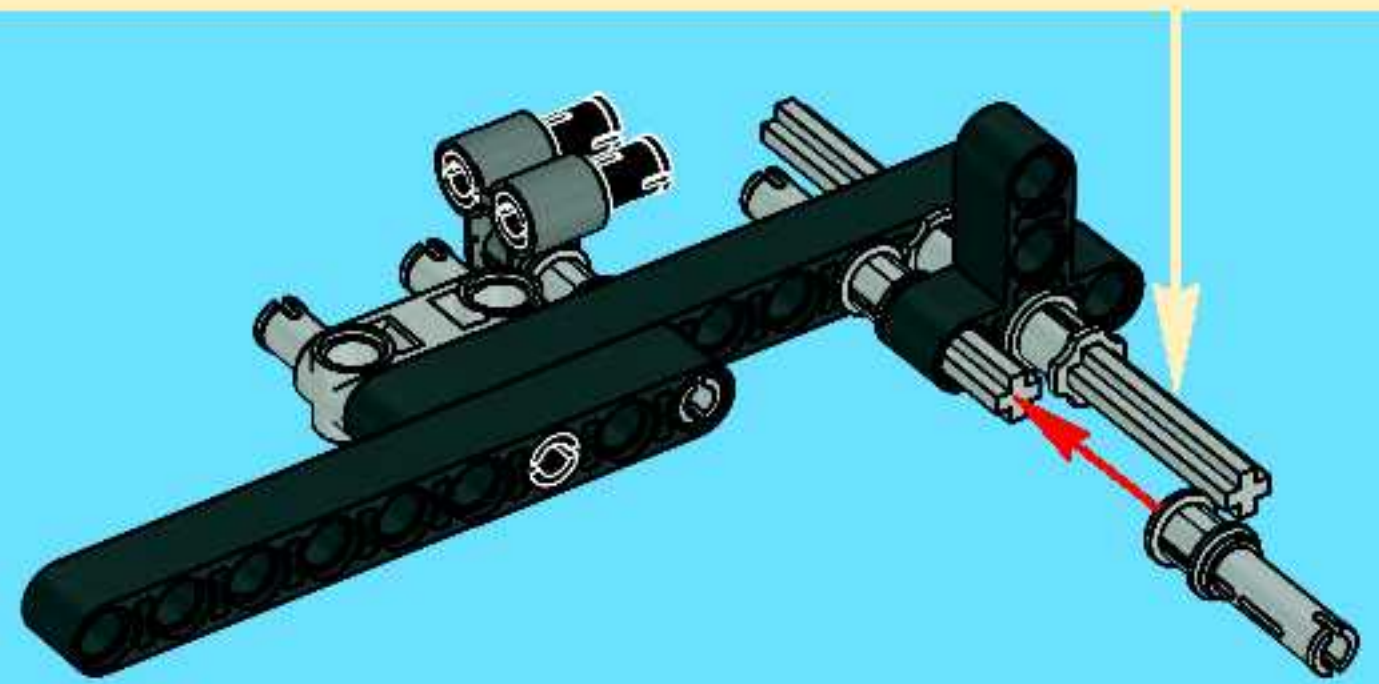
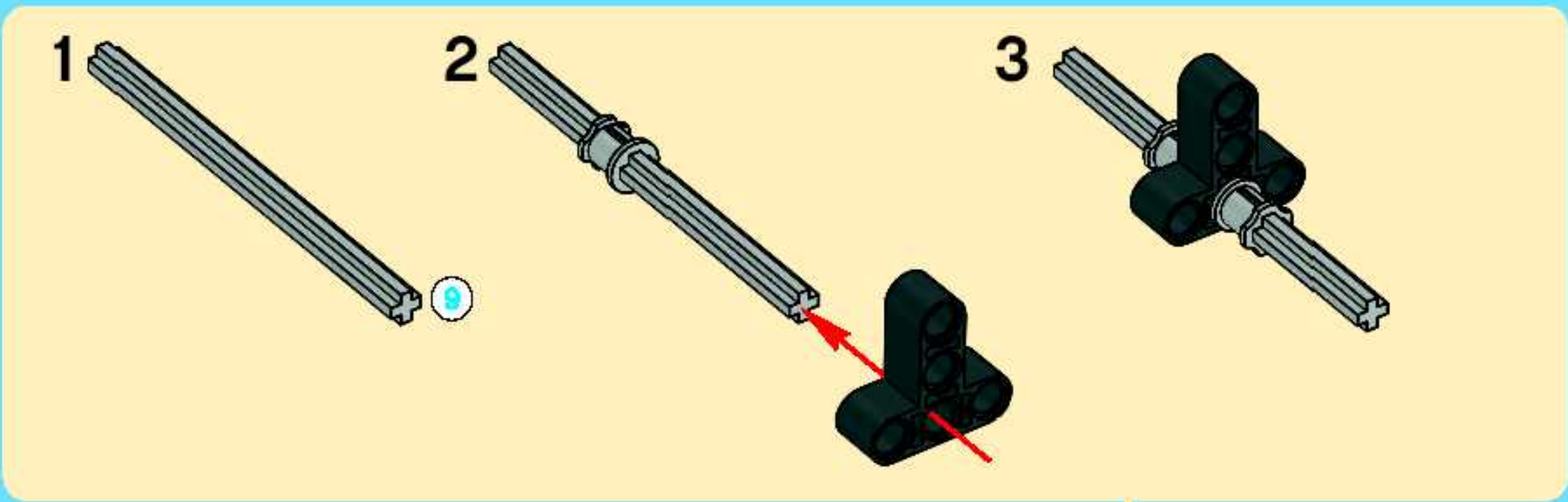





2x

6

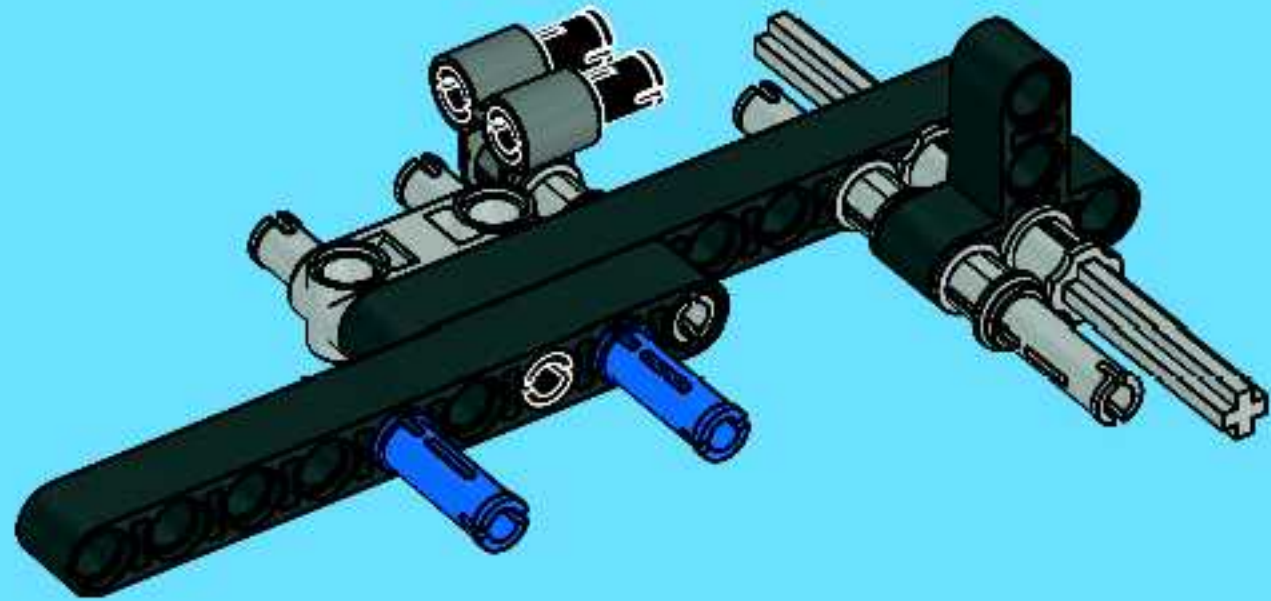

6



1x

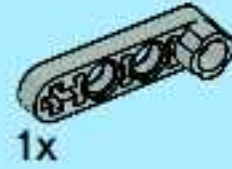

1x

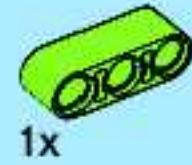

1x

7

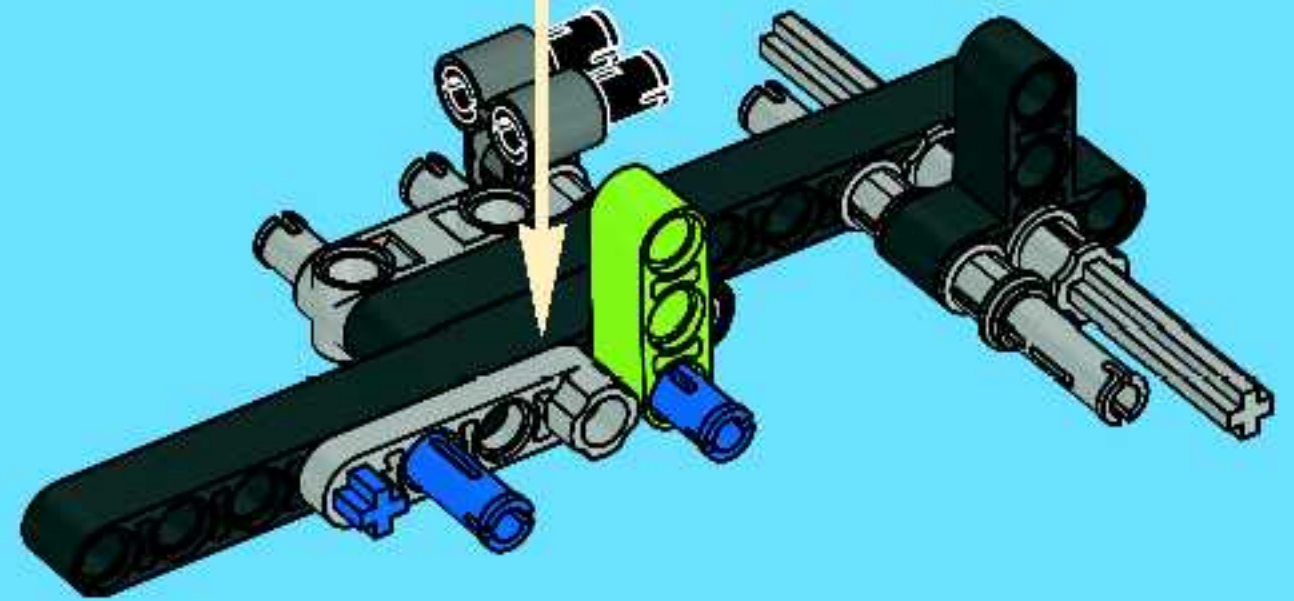
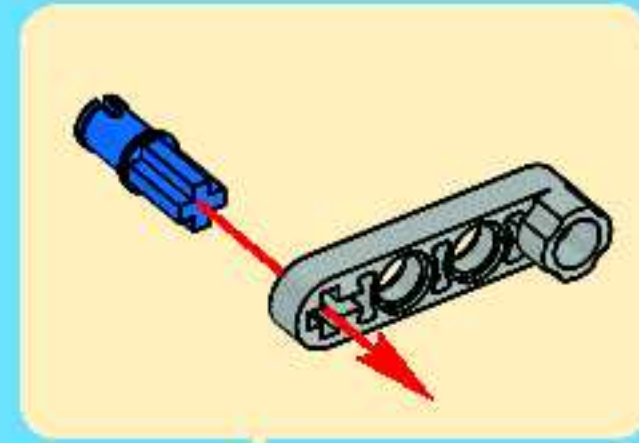



8

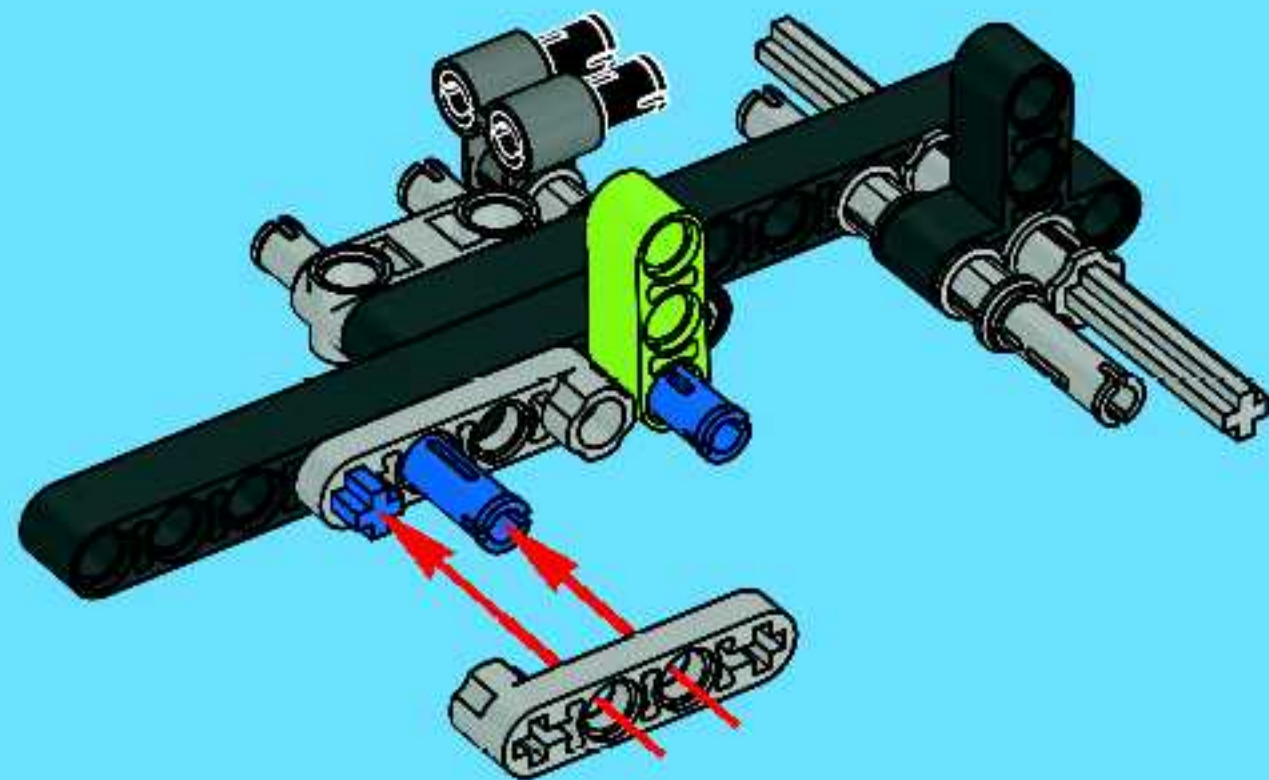



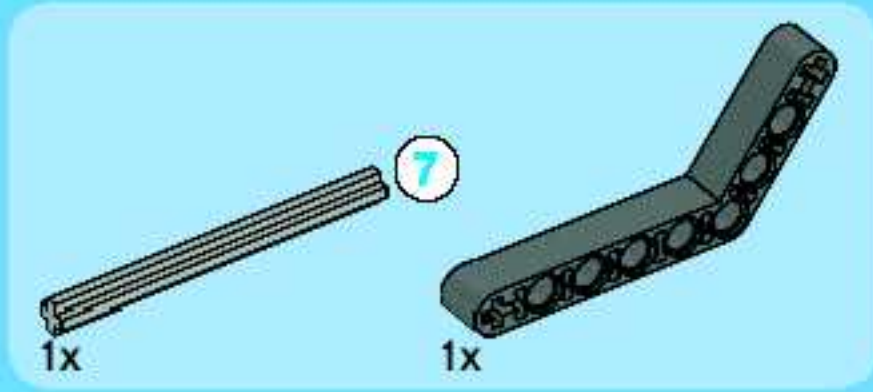
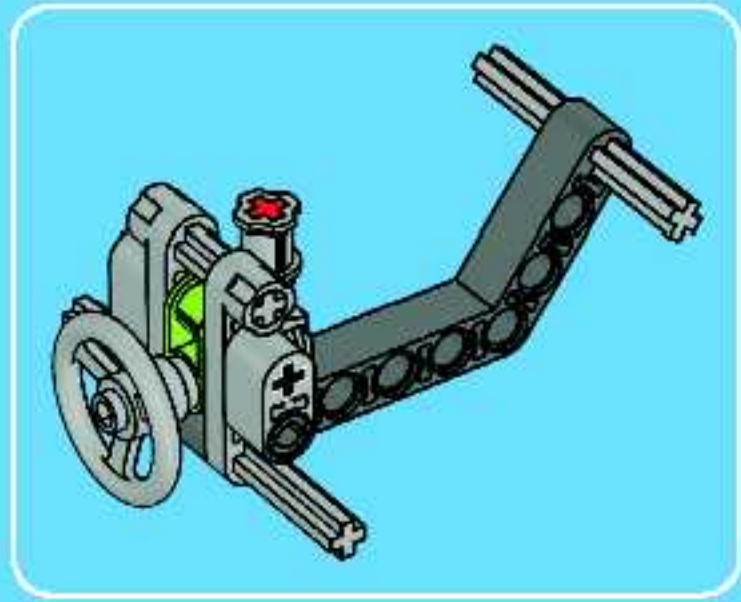

1

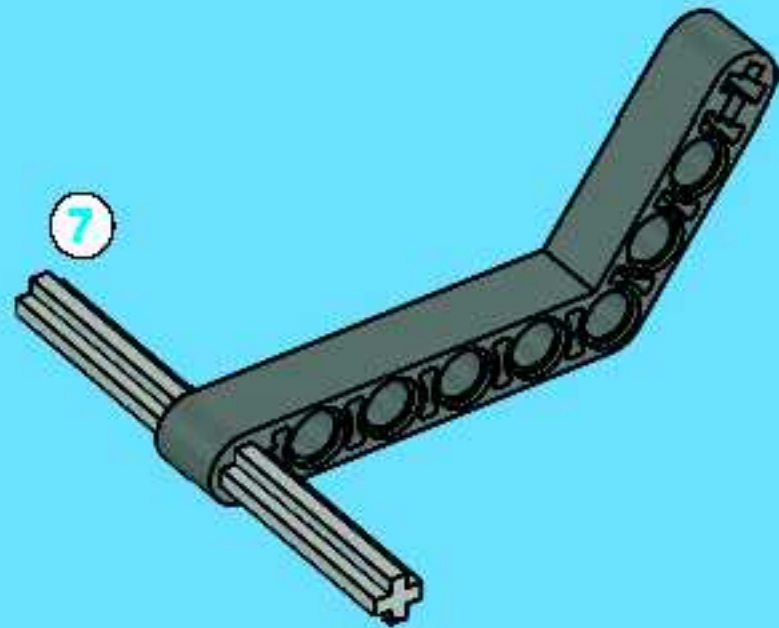

8

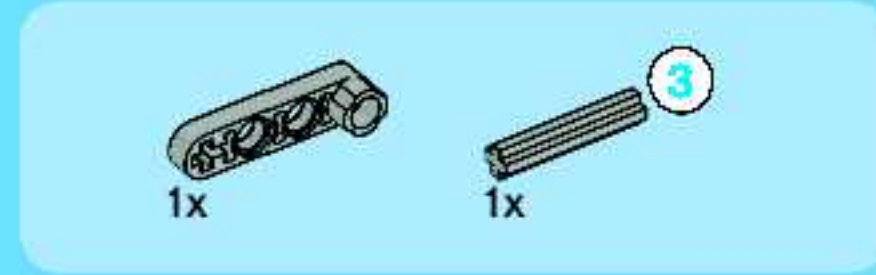

2

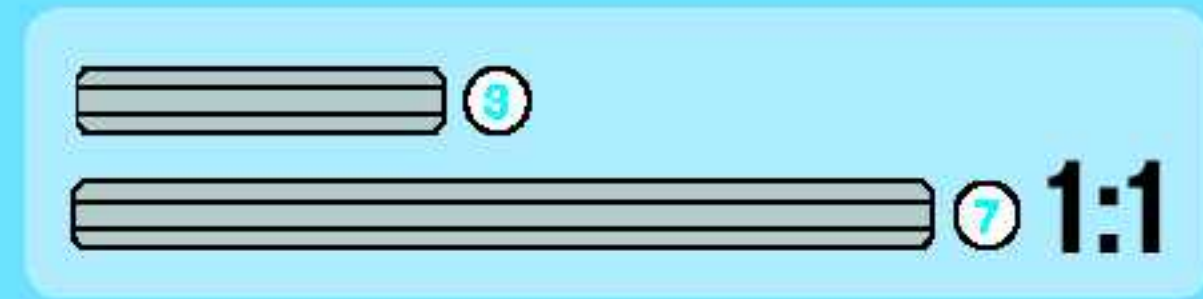
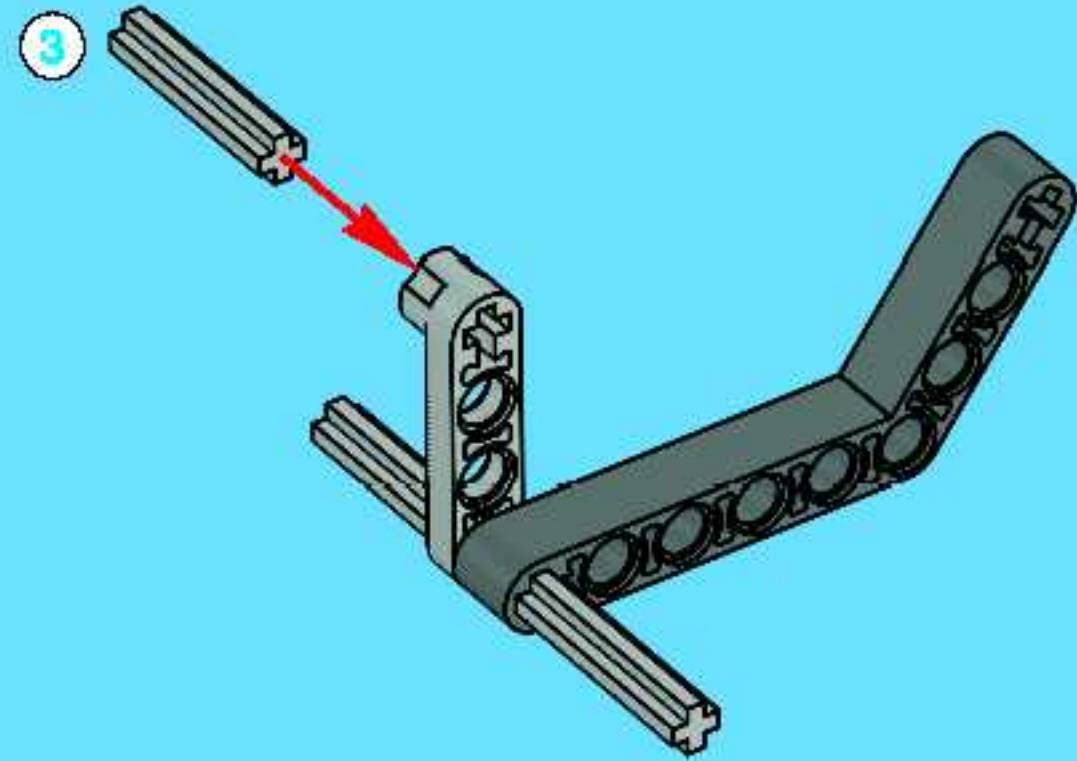

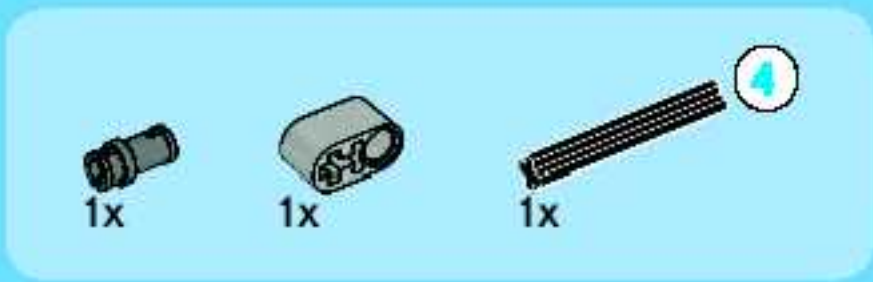

3

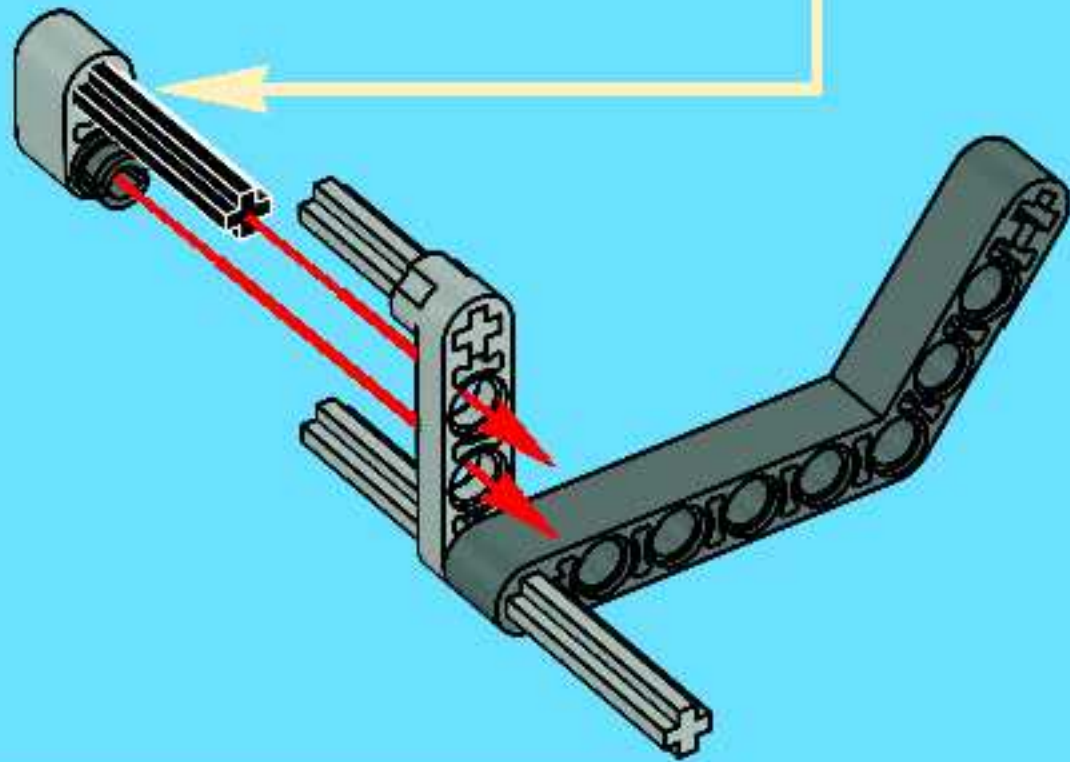
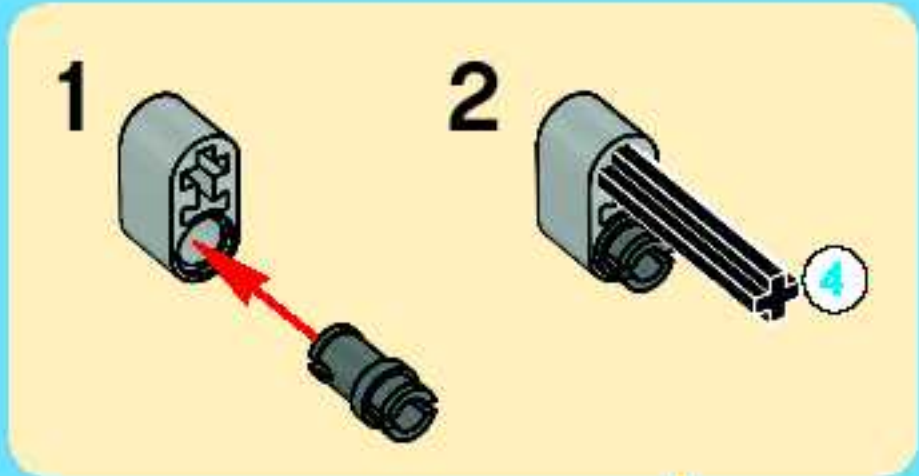

4

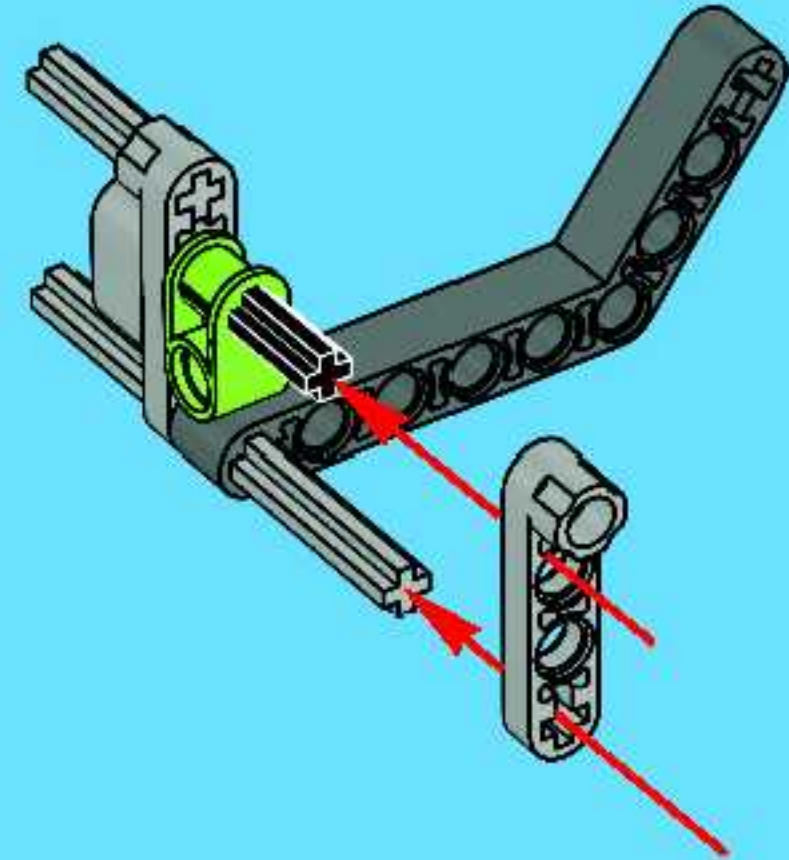



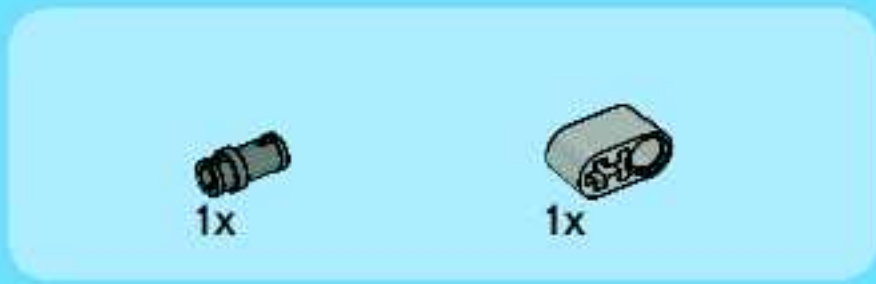

5

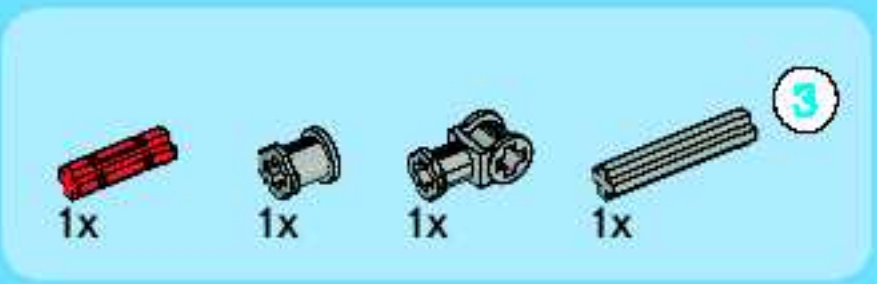
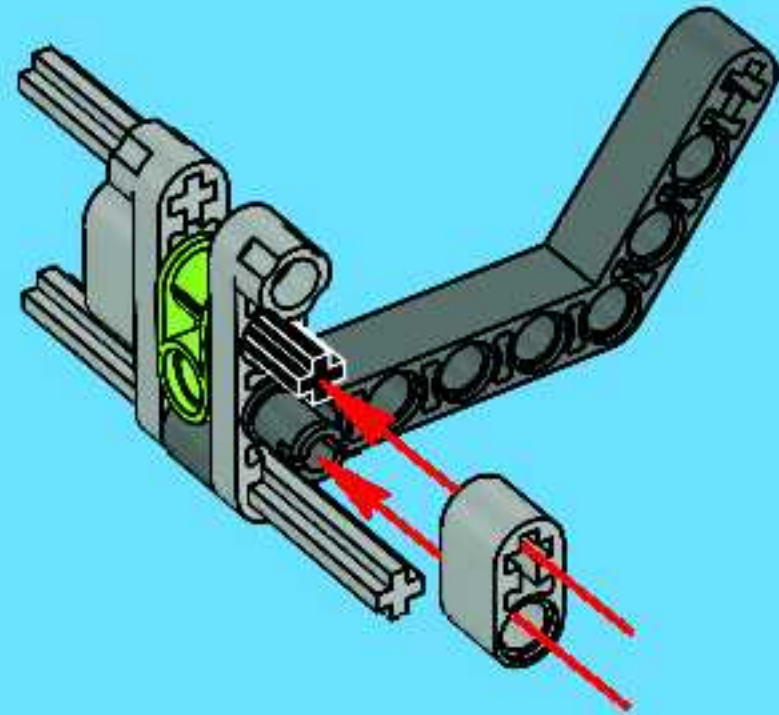

6

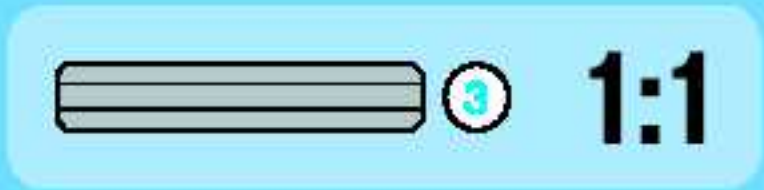
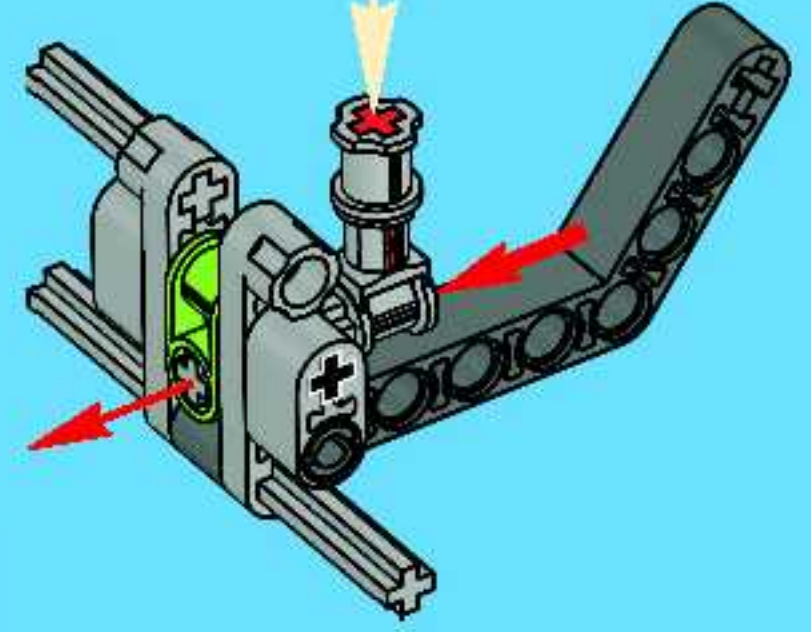
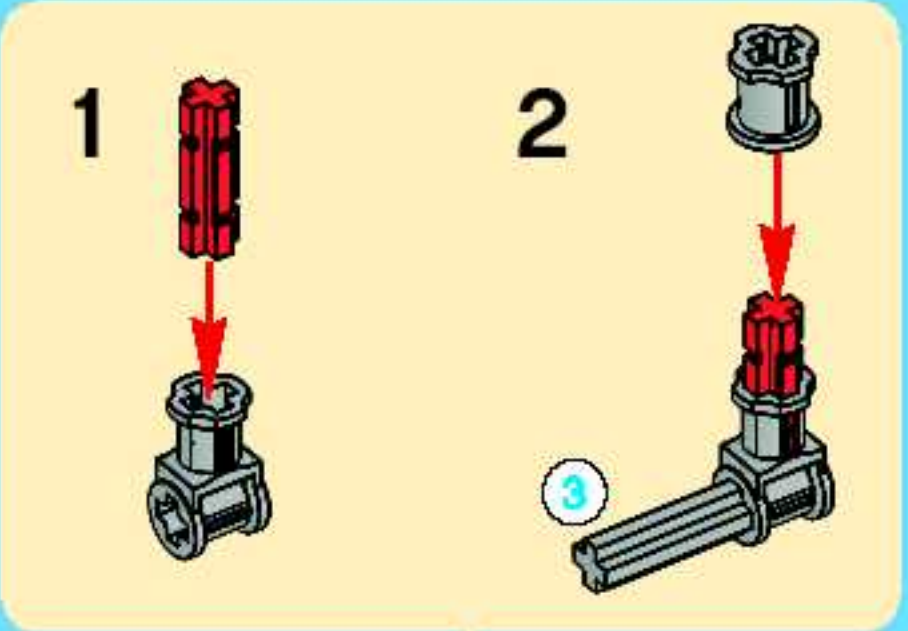

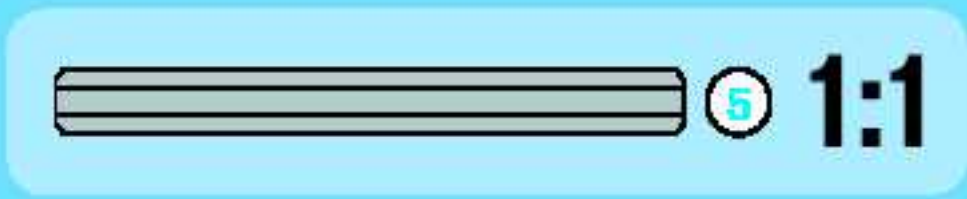
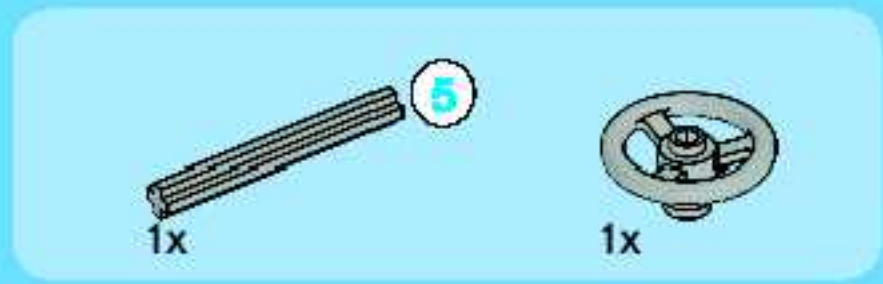

7

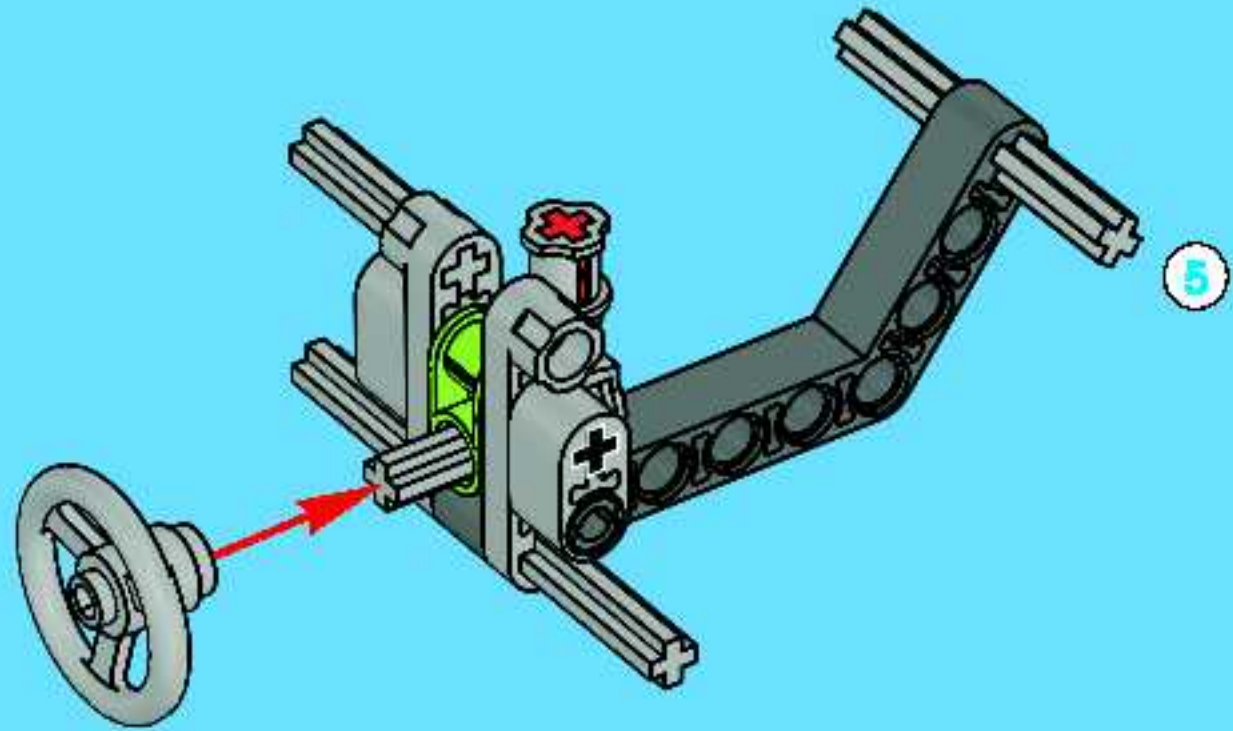



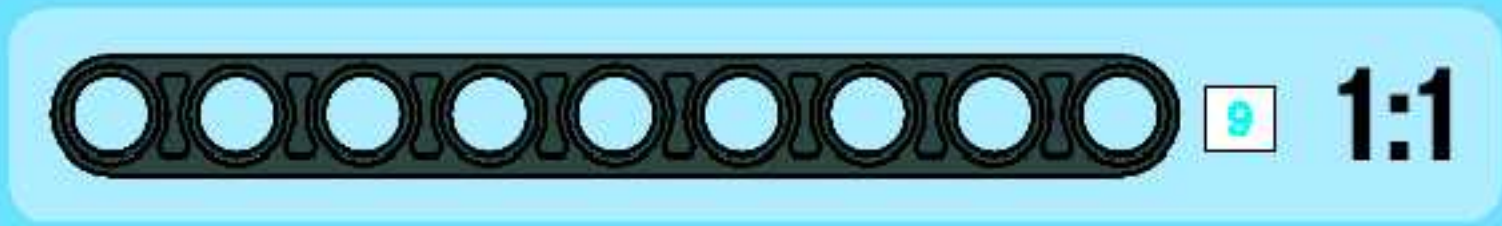

8

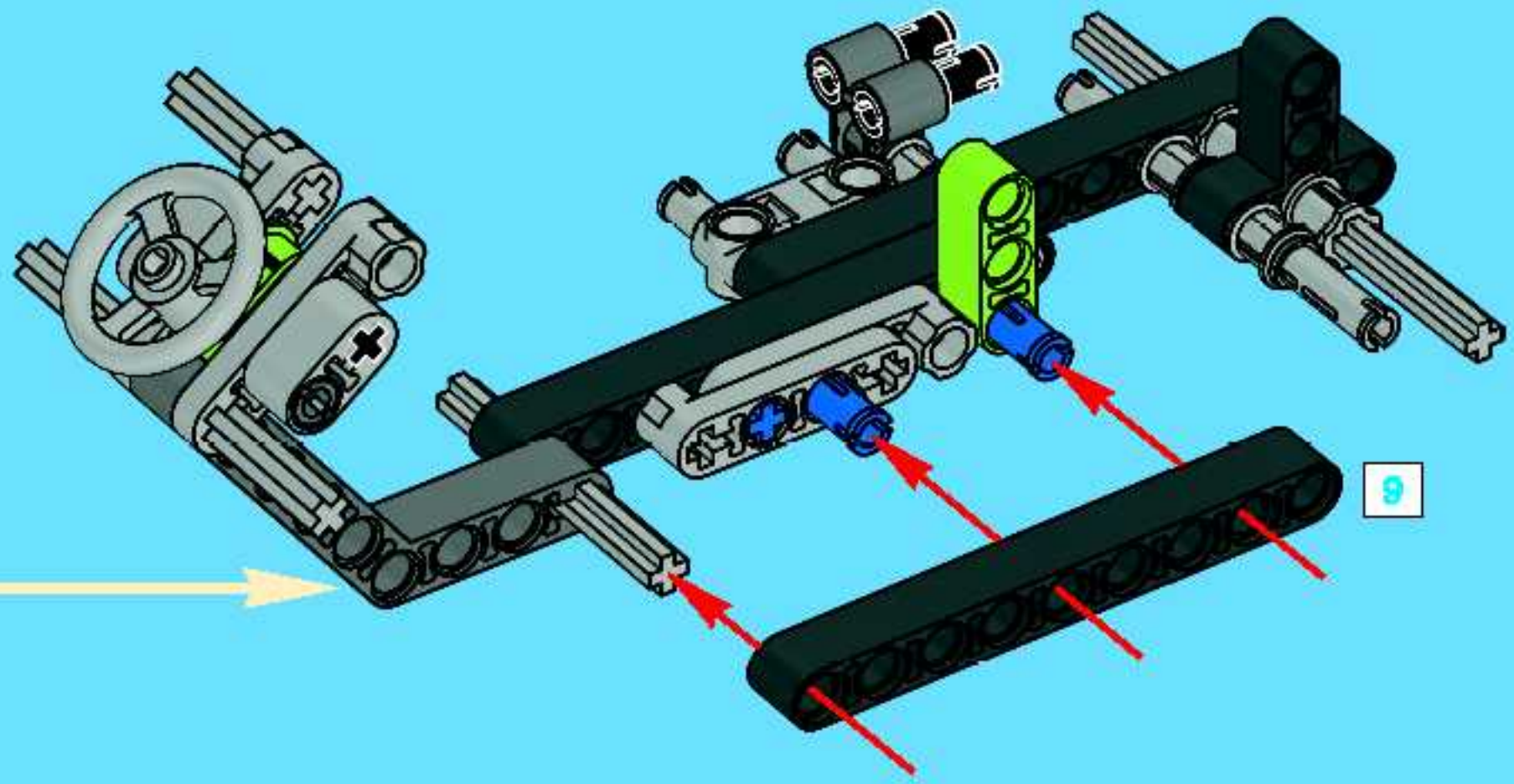

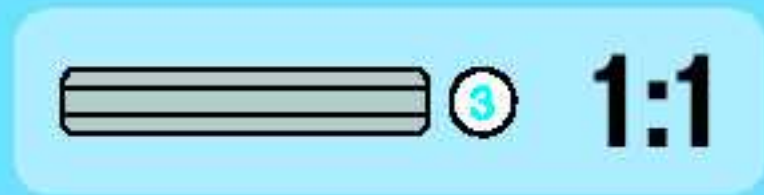
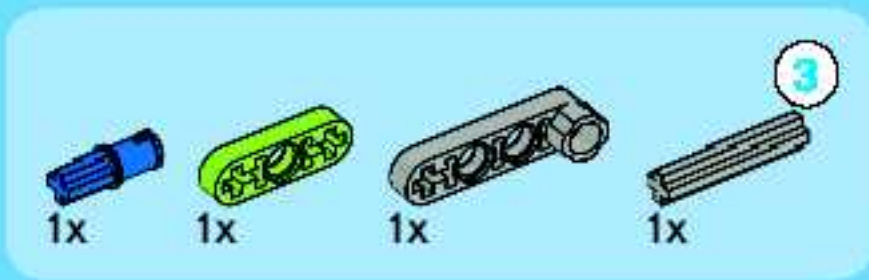

9

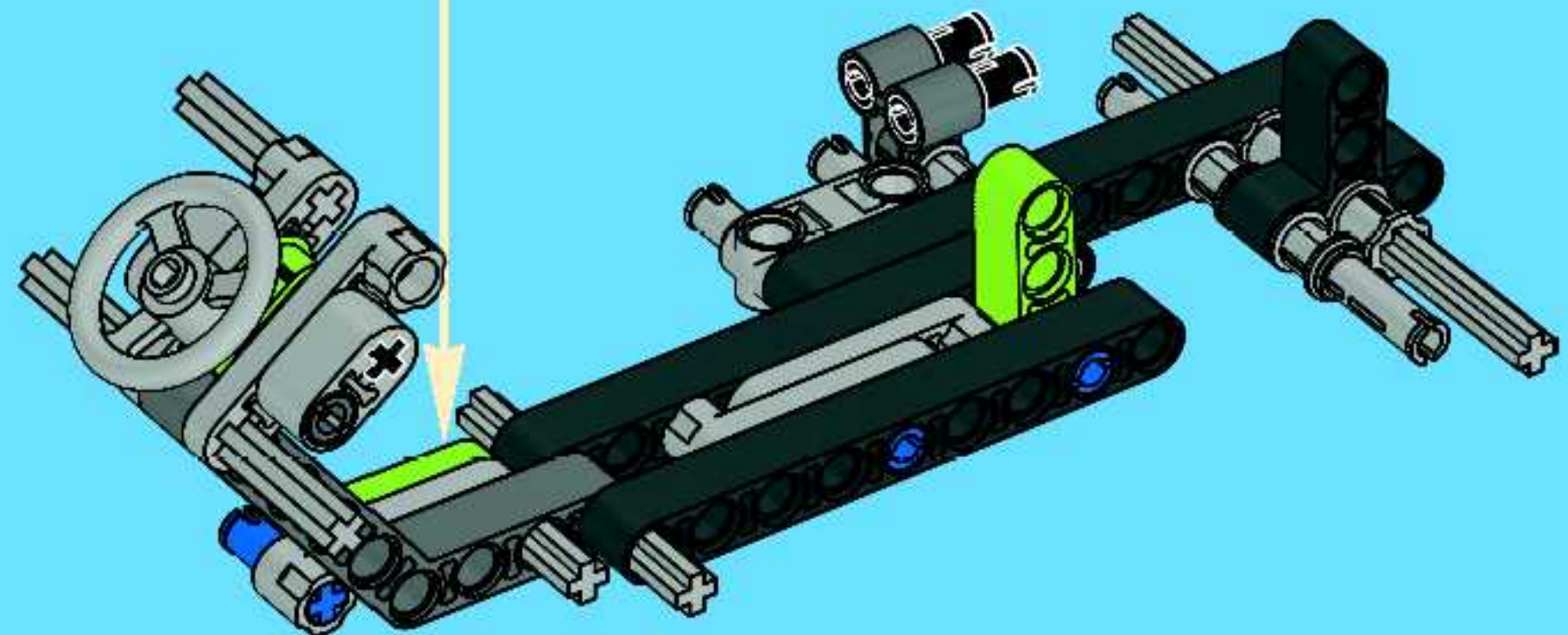
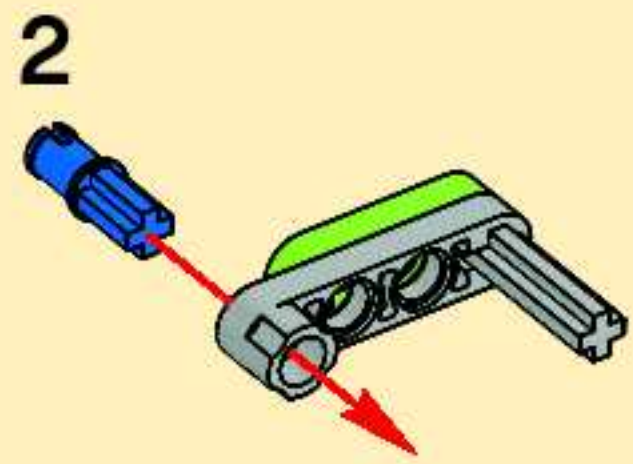
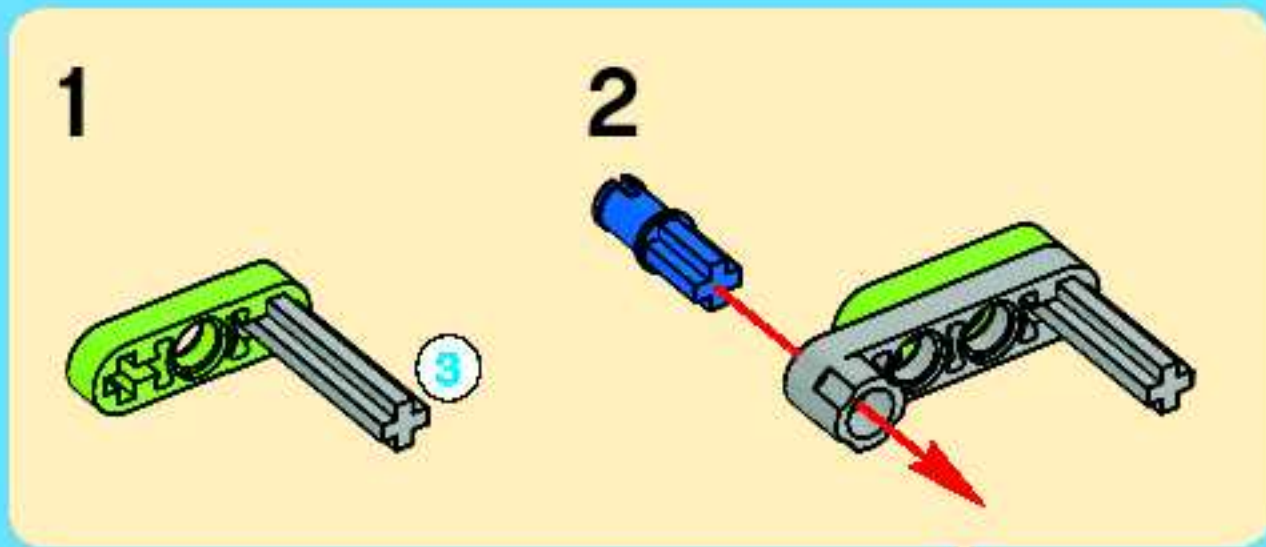





1x



1x

# 10

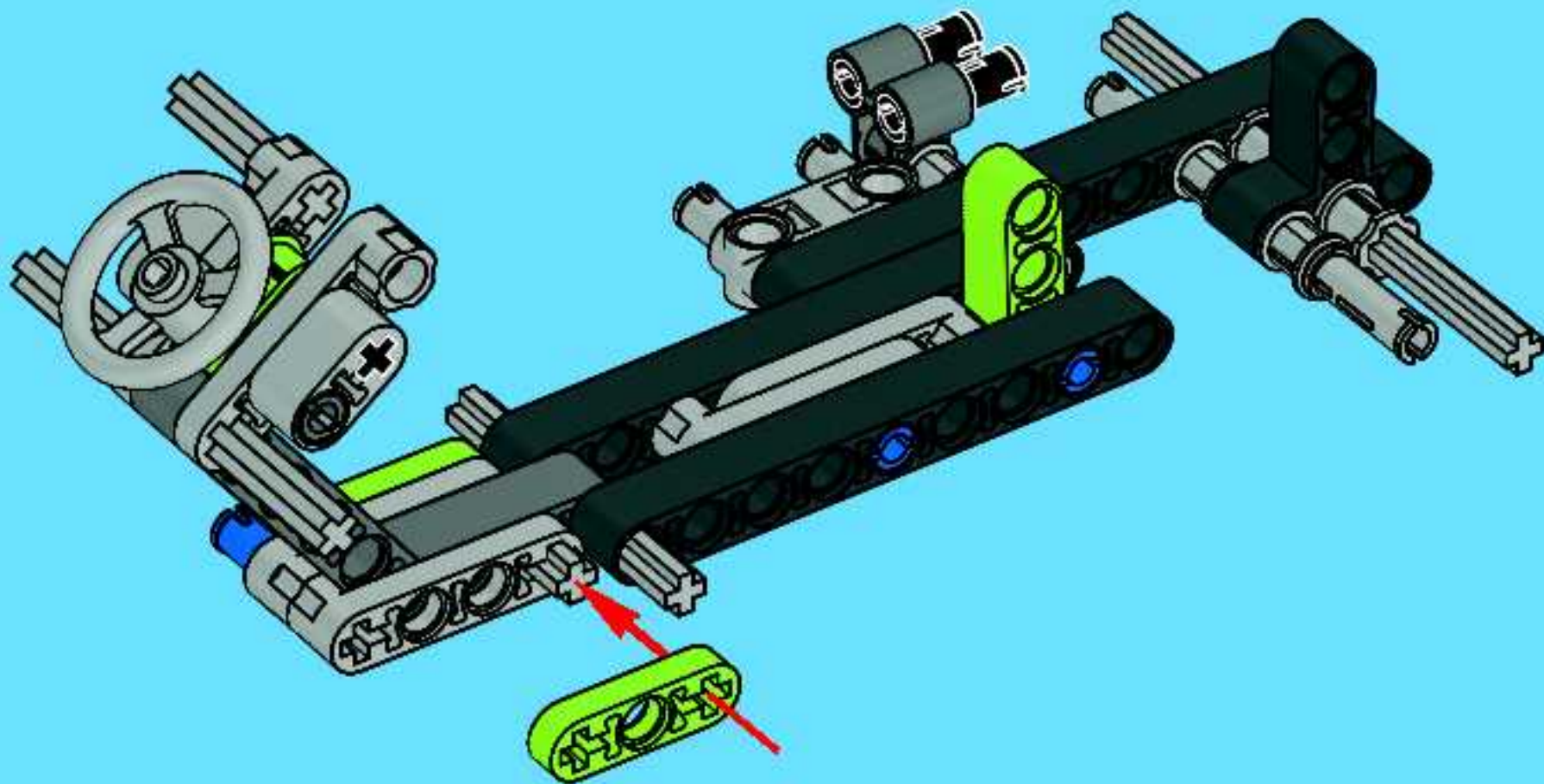

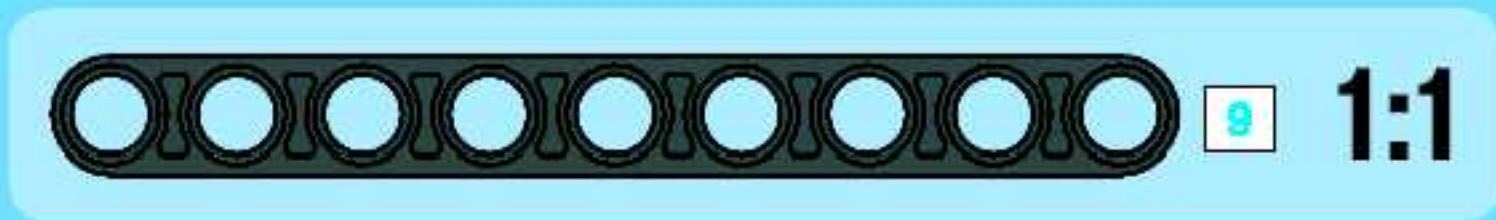

11

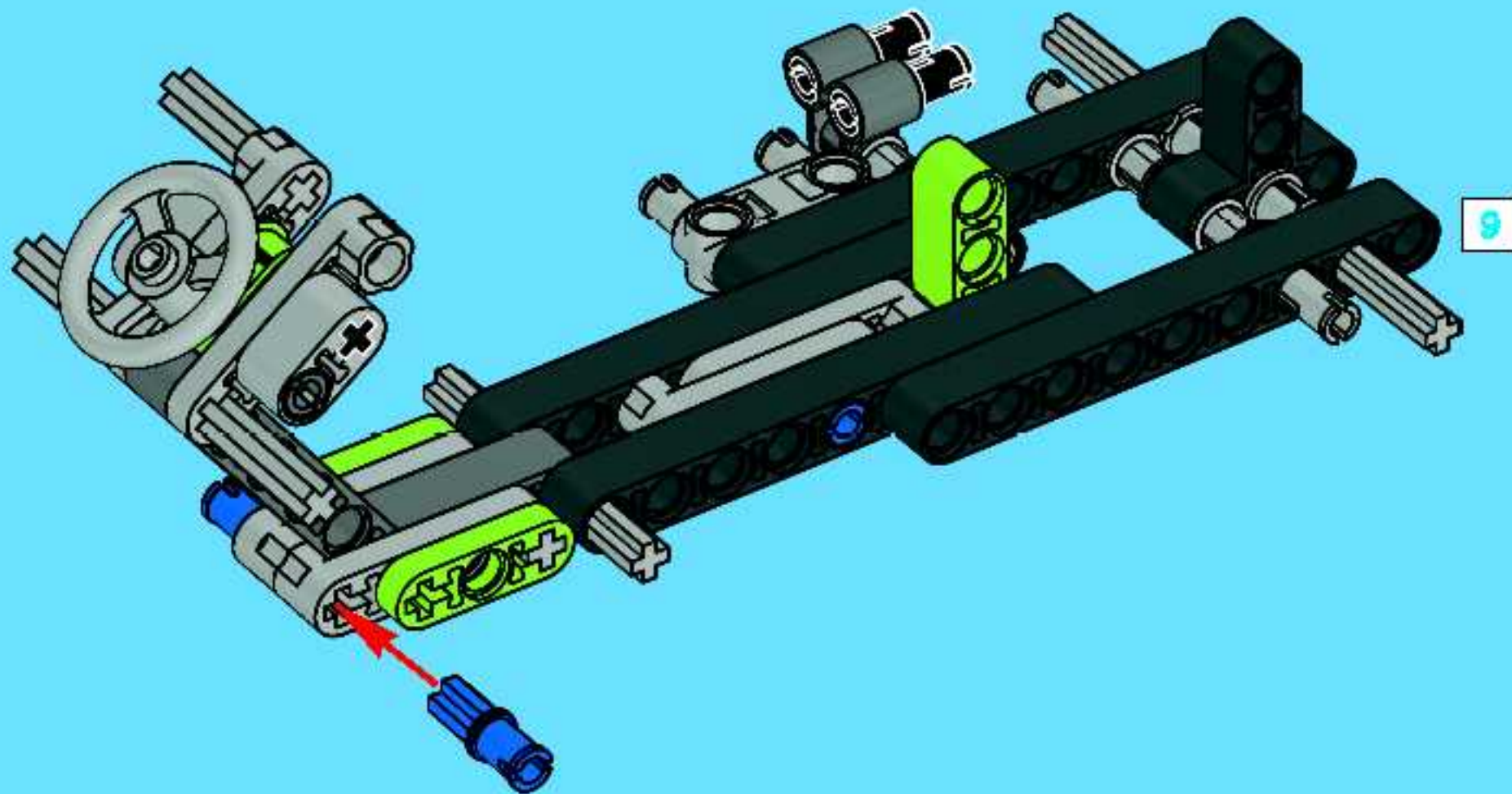



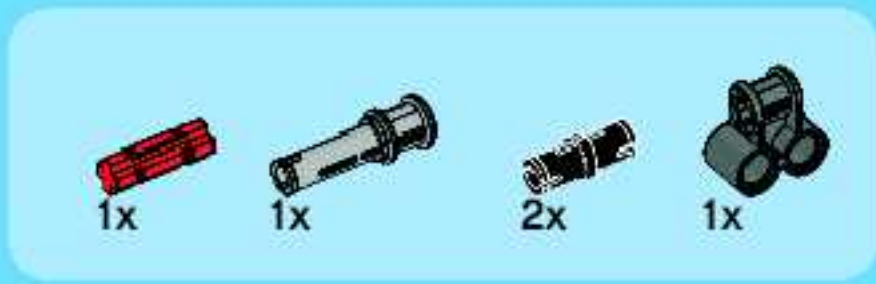

12

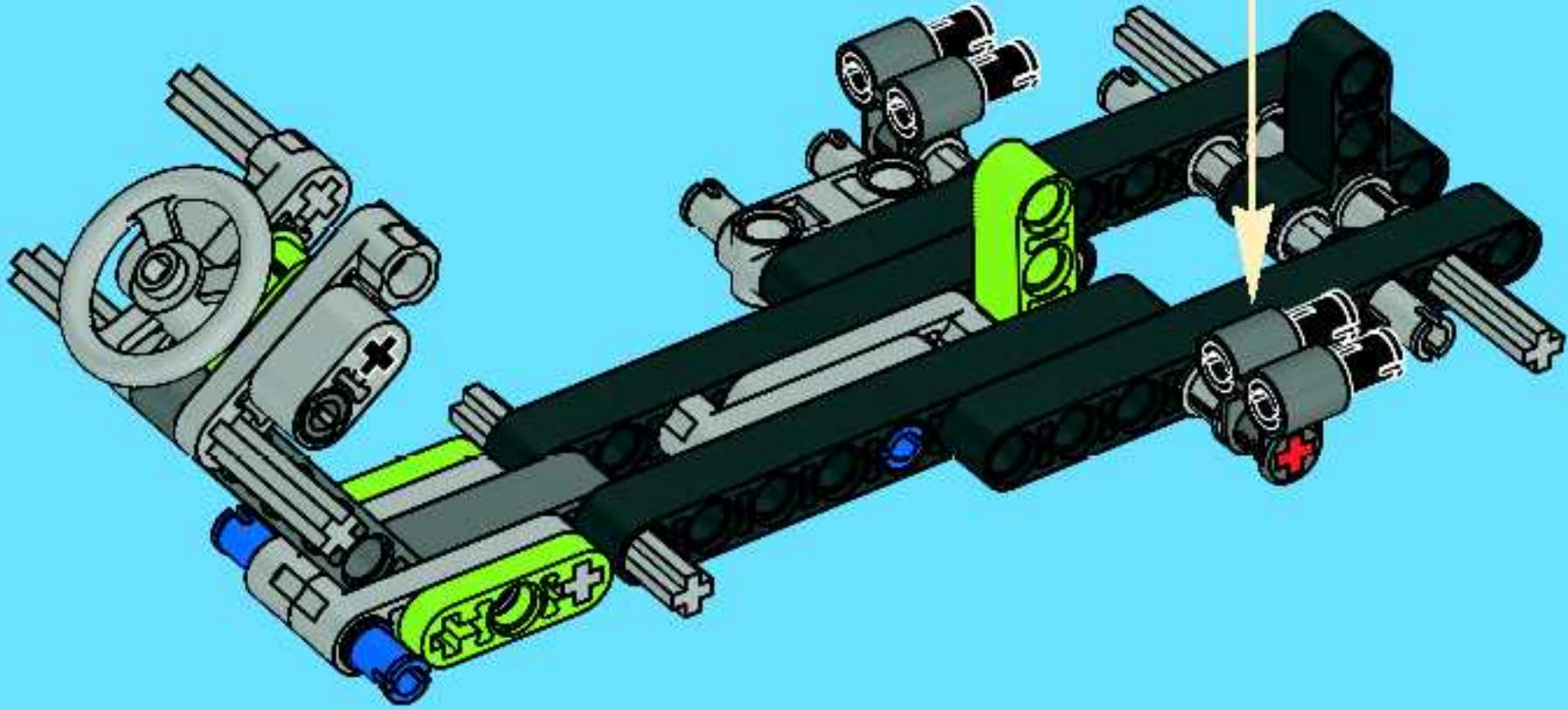
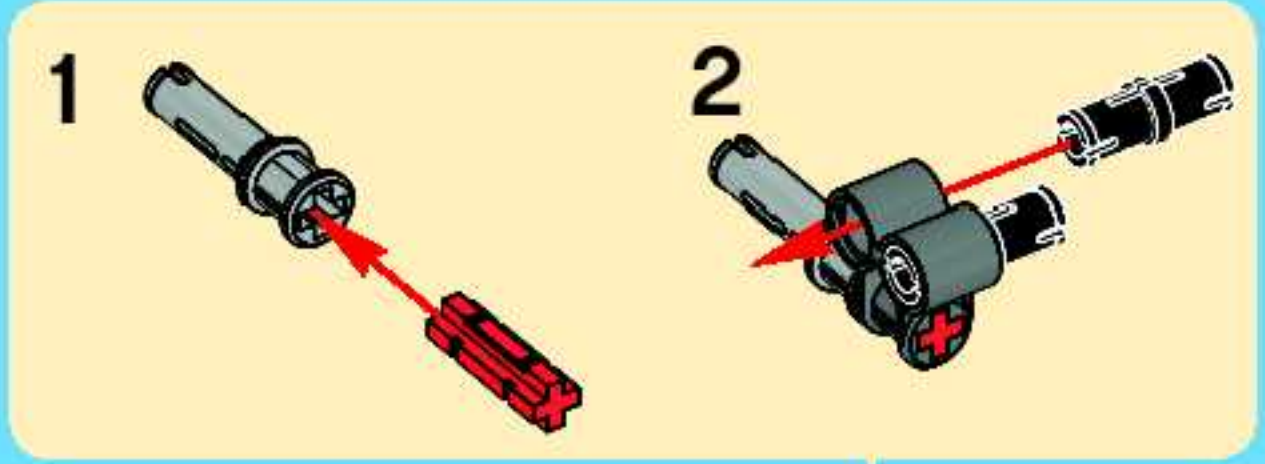



2x



2x



2x

# 13

1



2

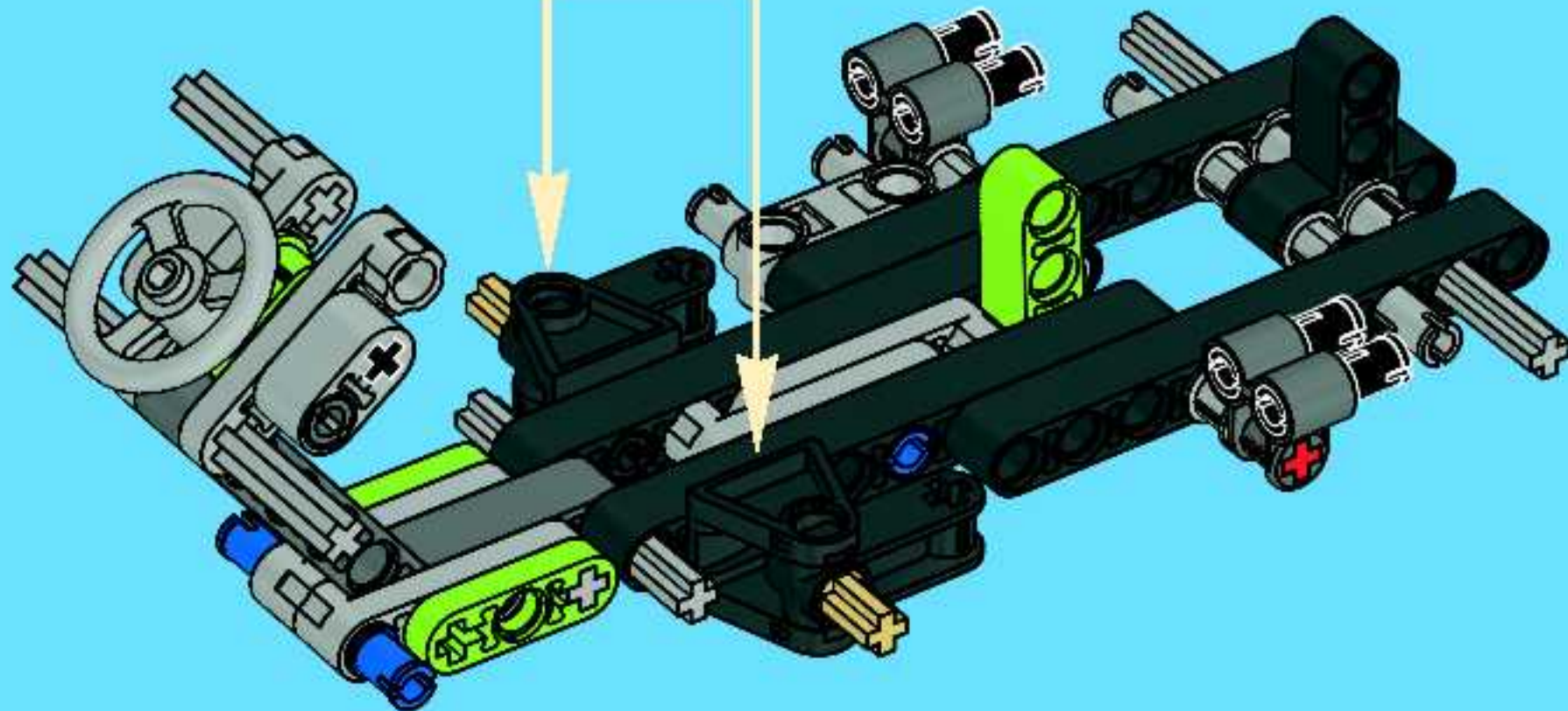
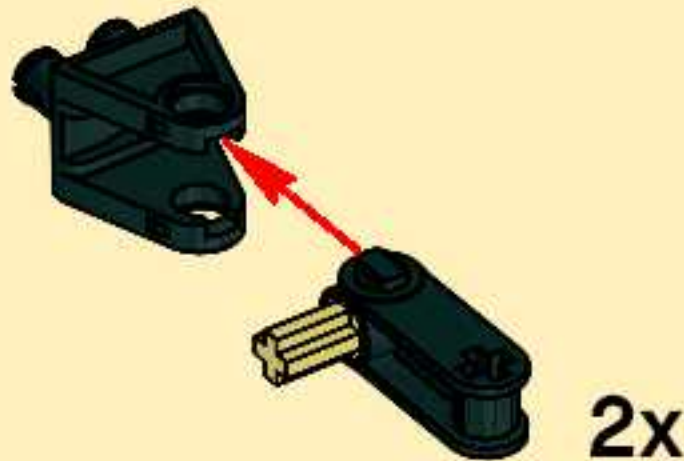





14

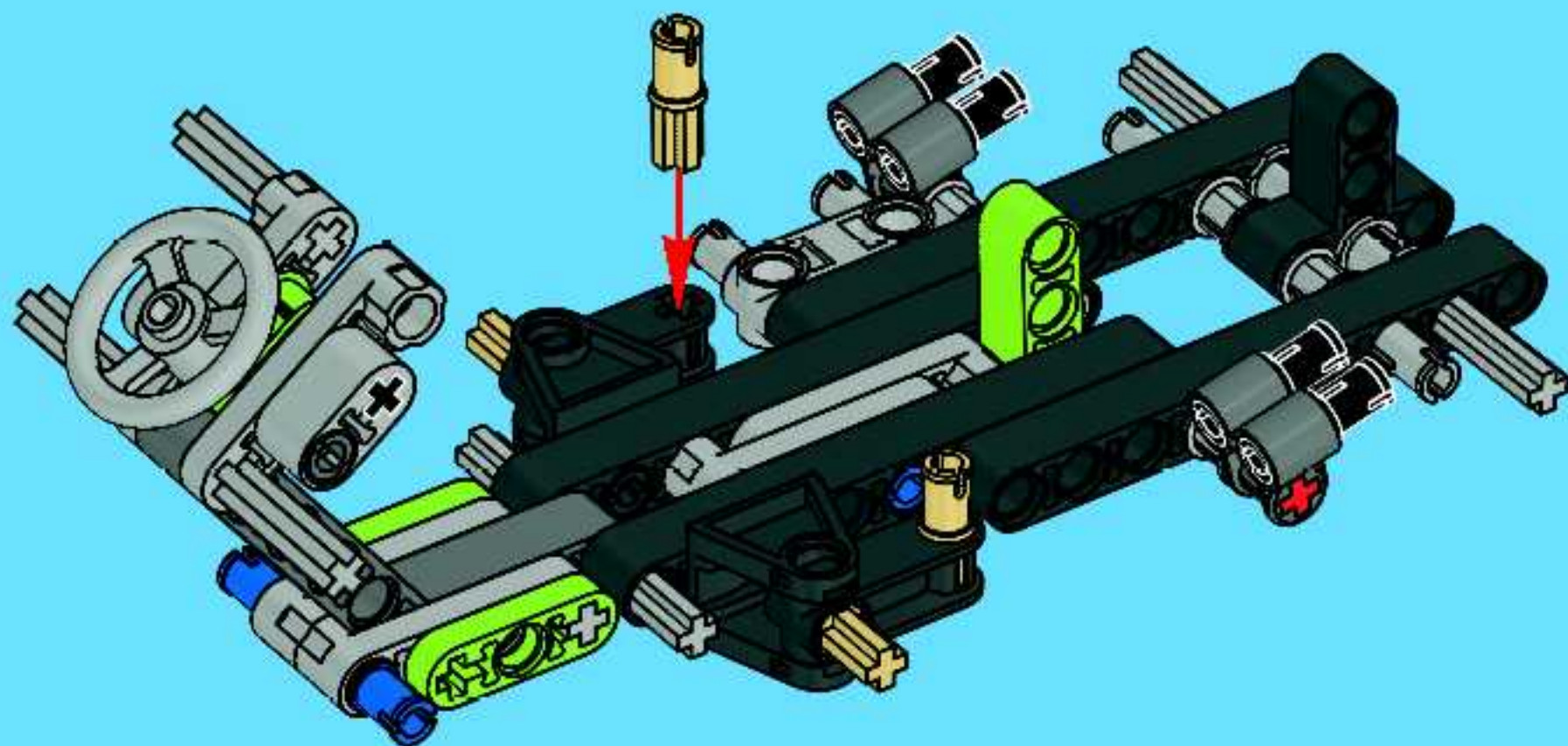

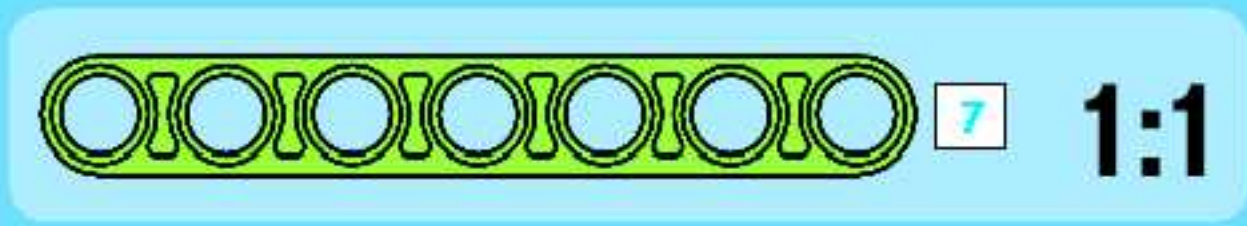
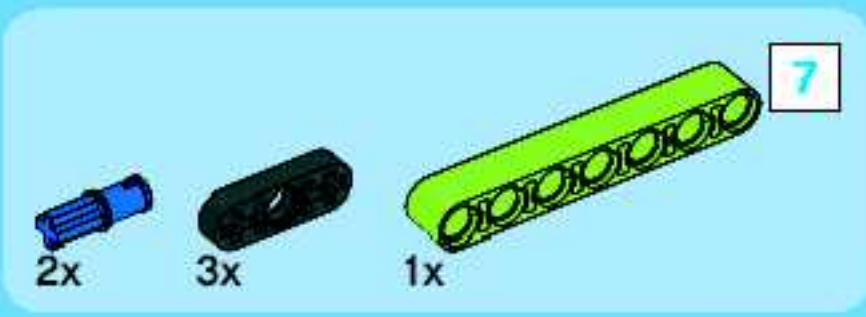

15

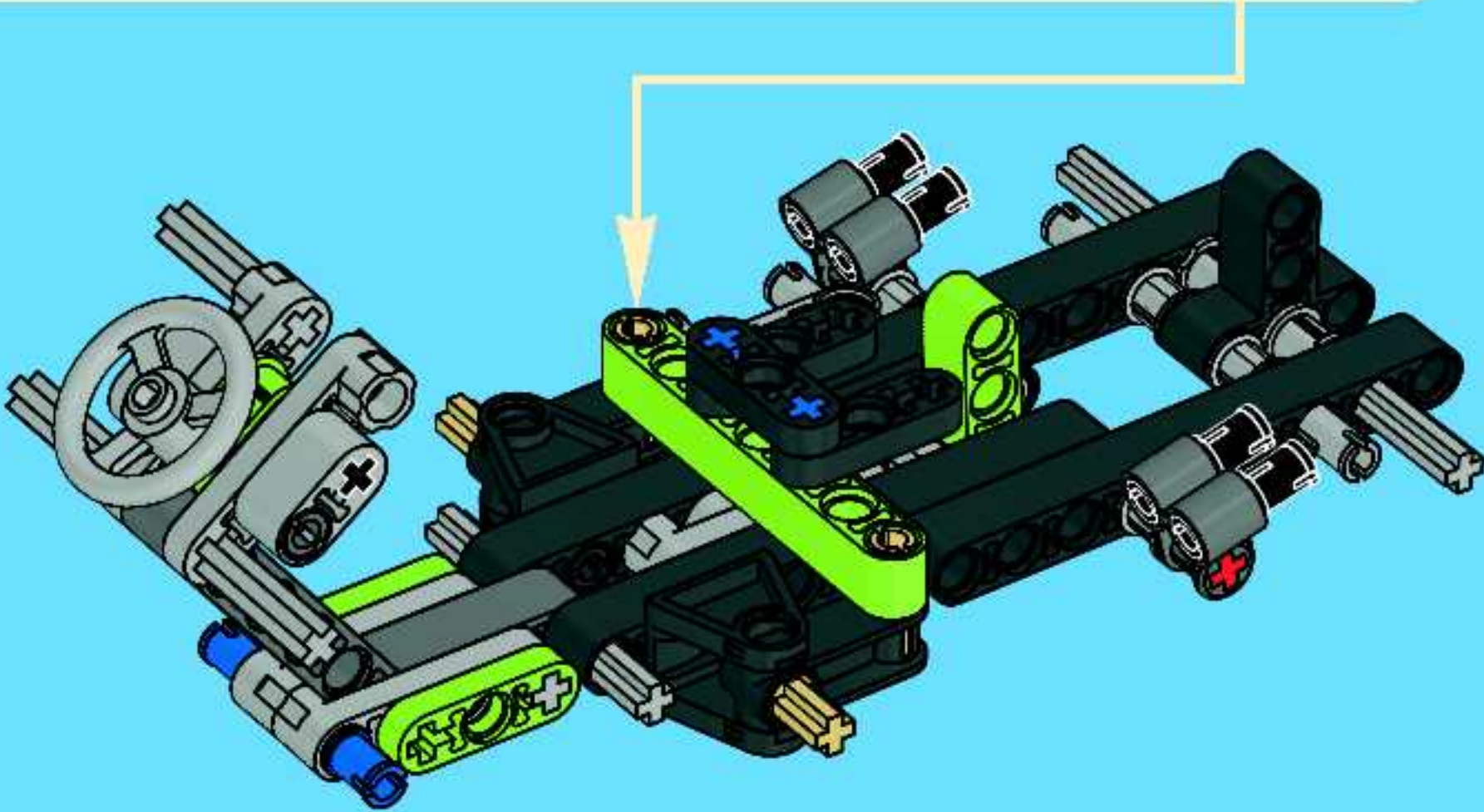
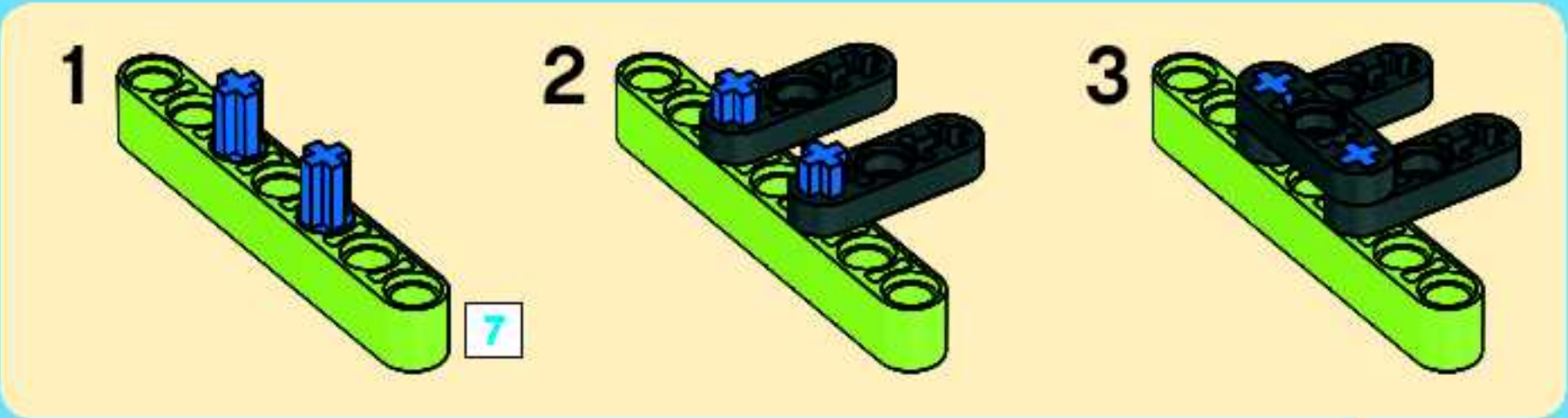



16

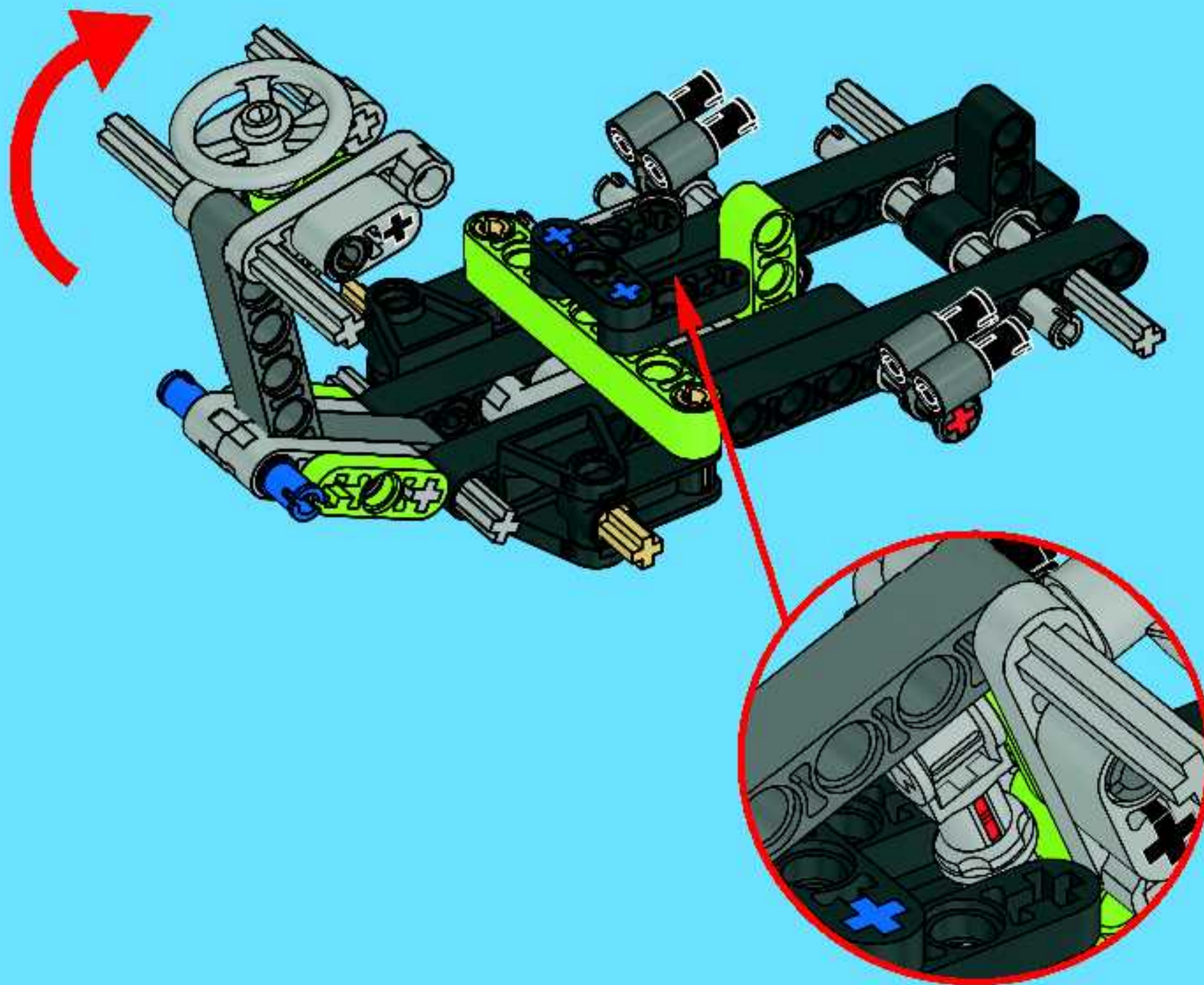



# 17

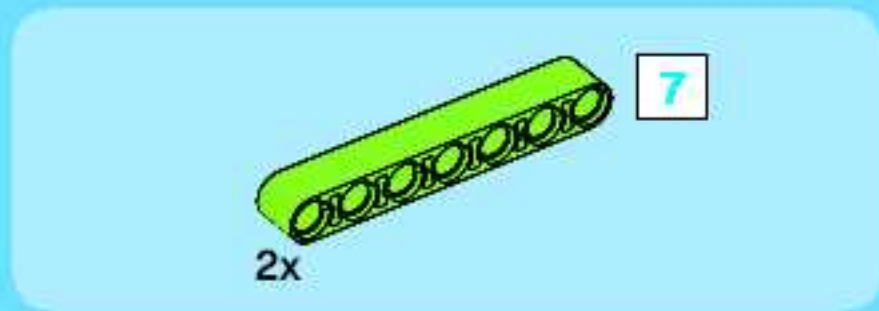
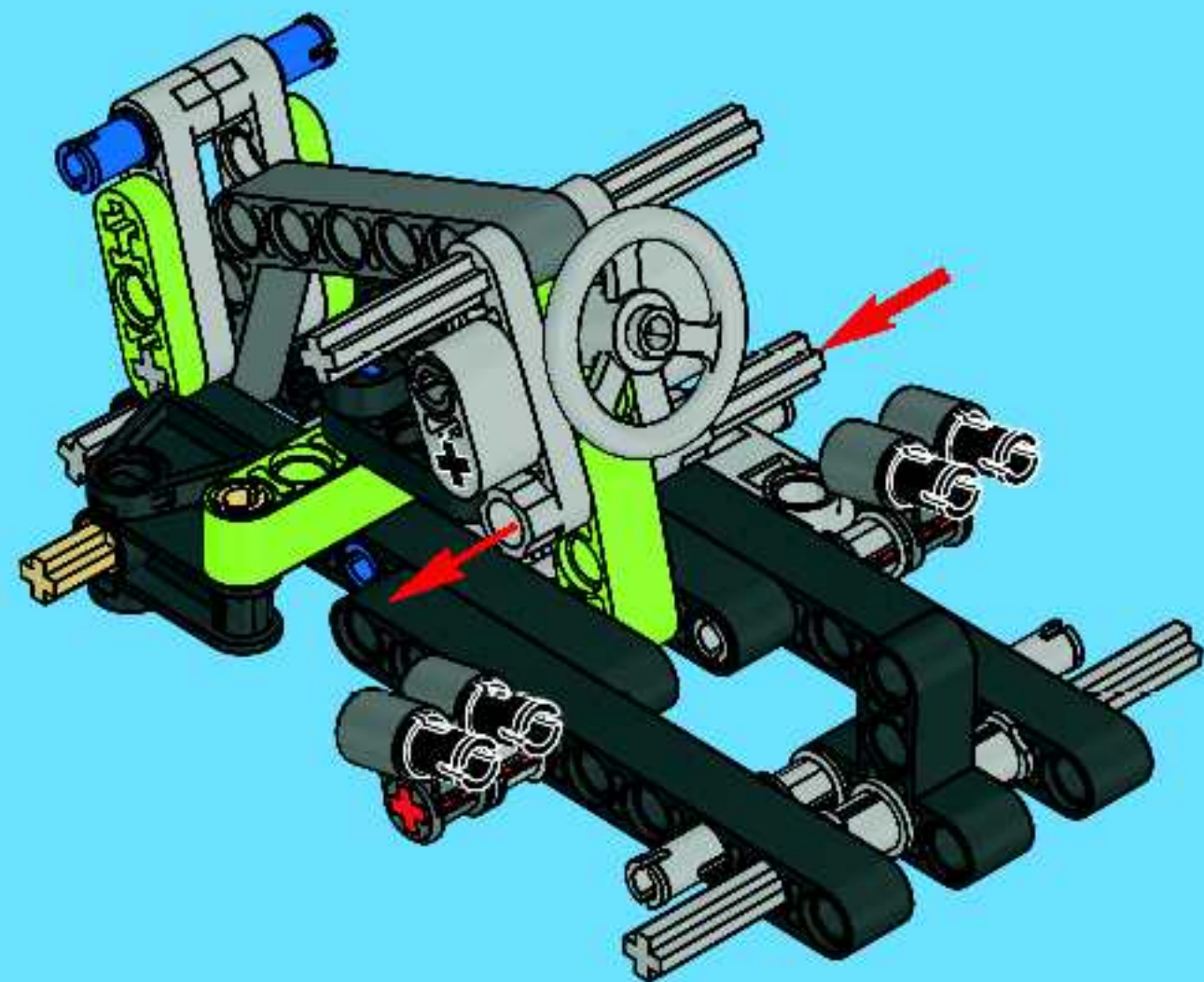

# 18

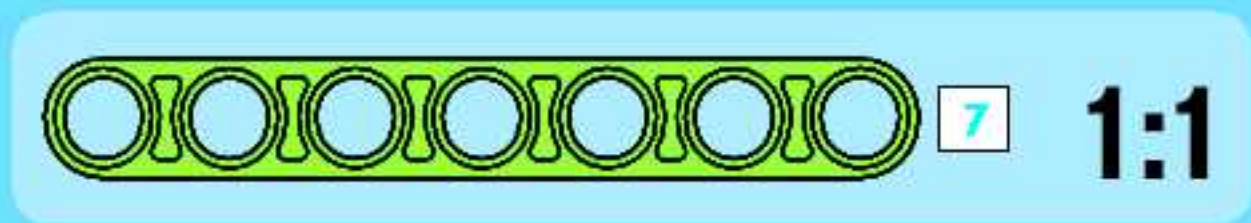
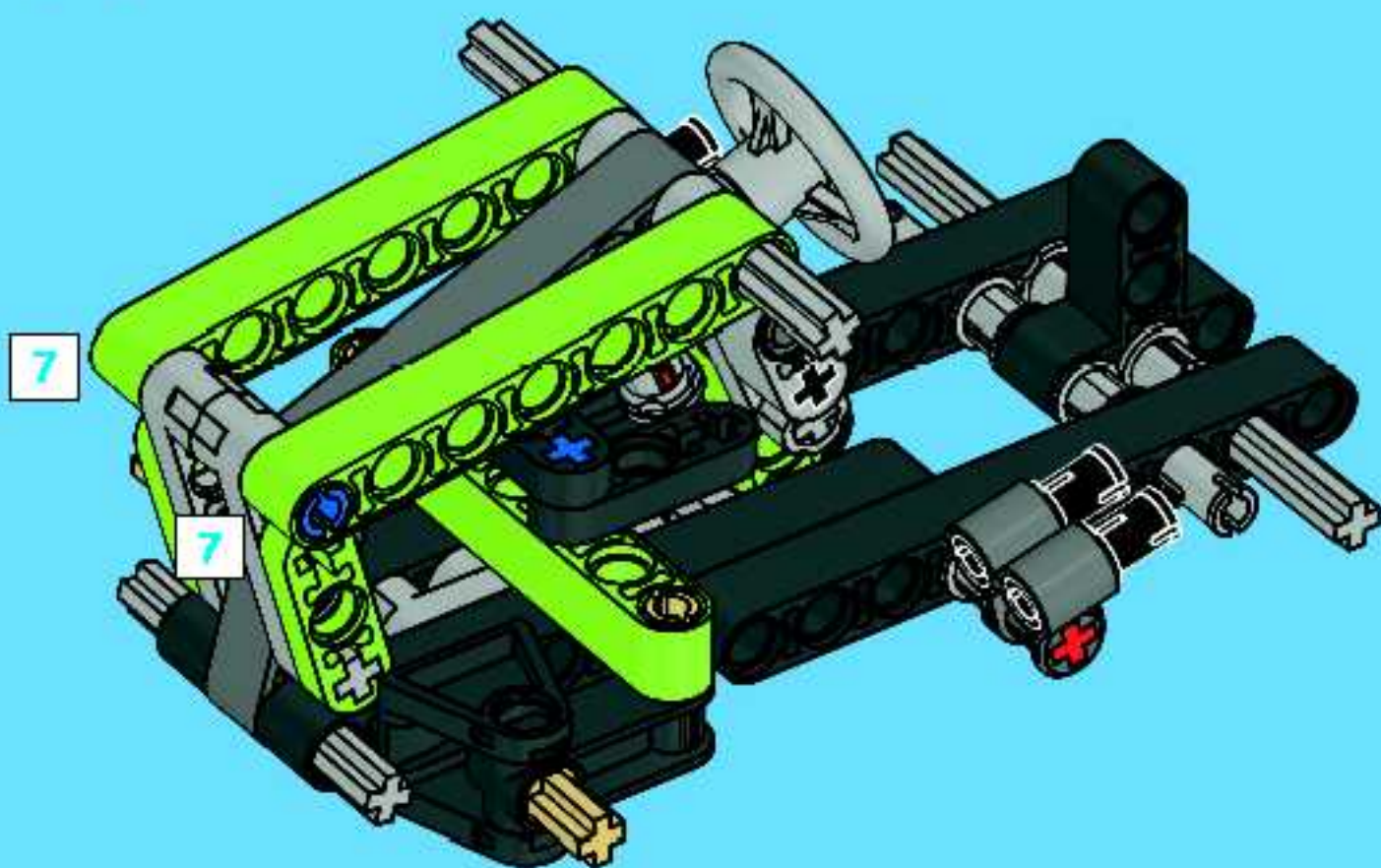



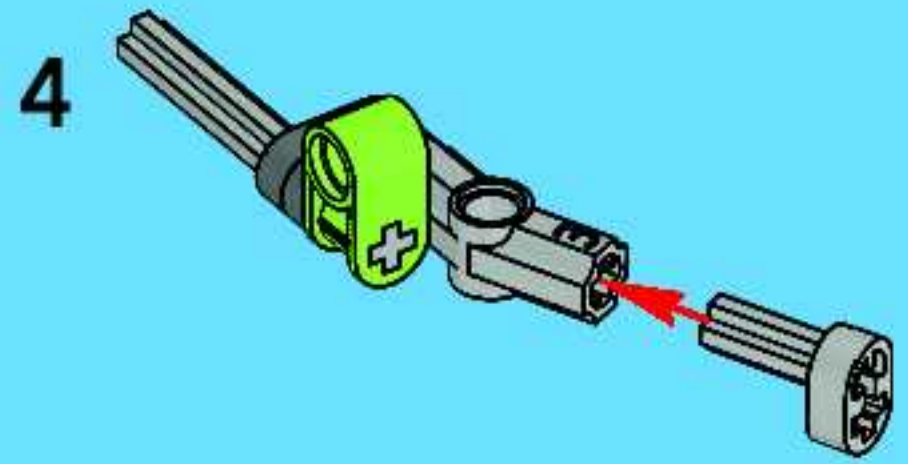
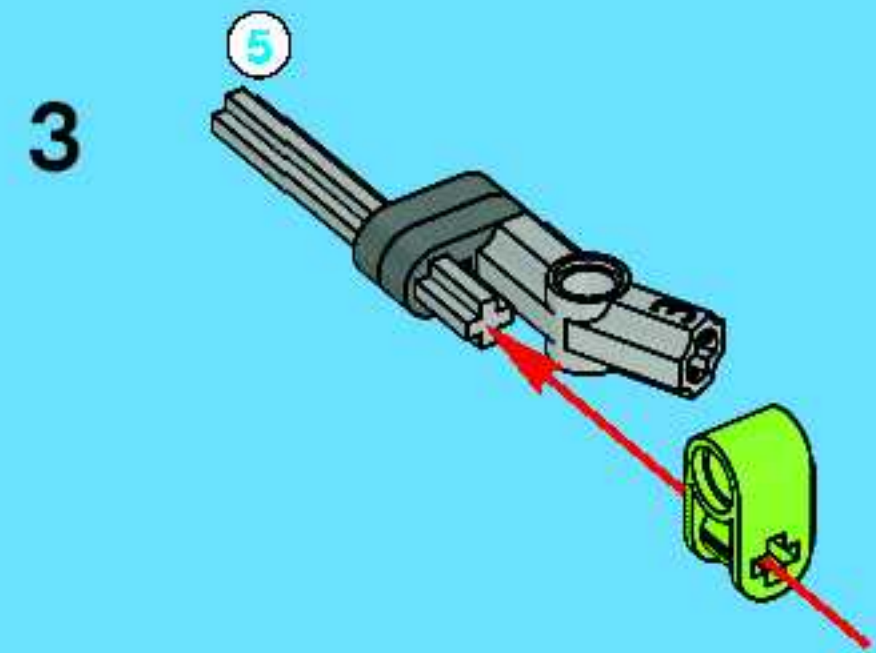
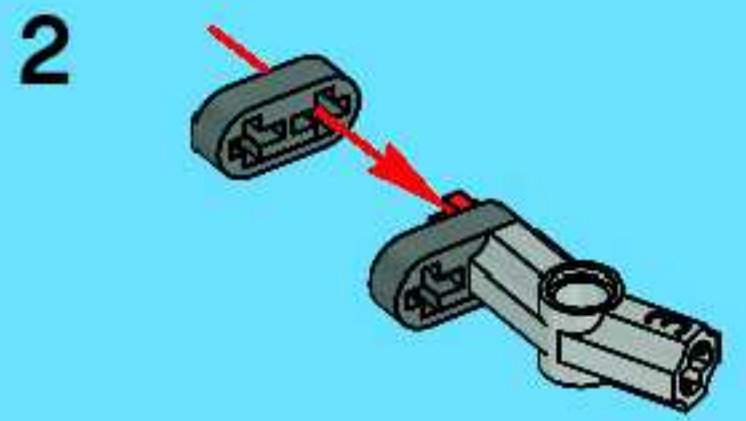
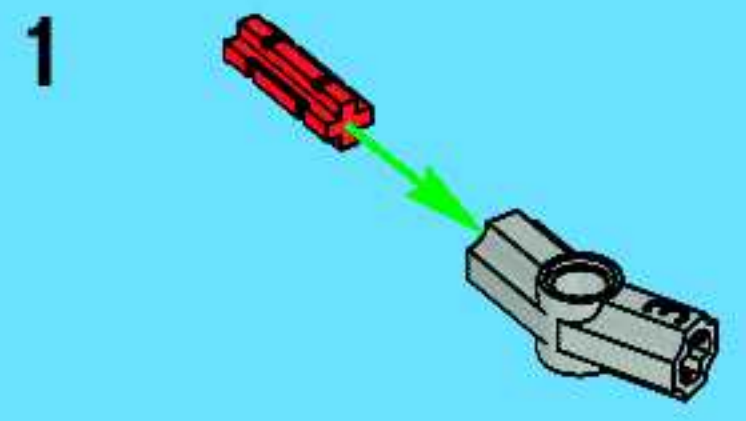
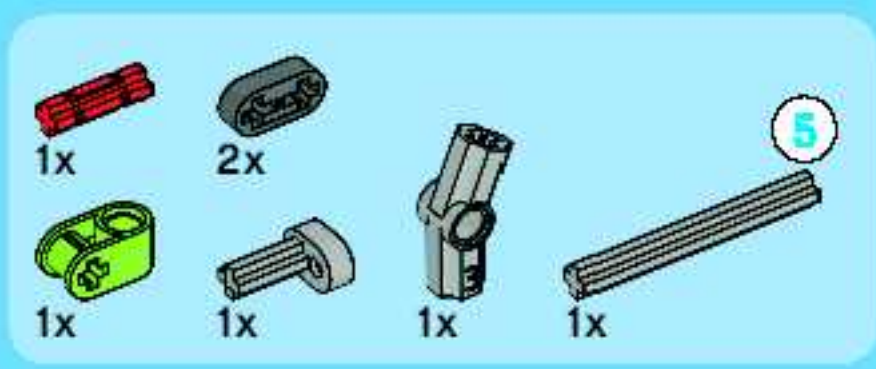

19

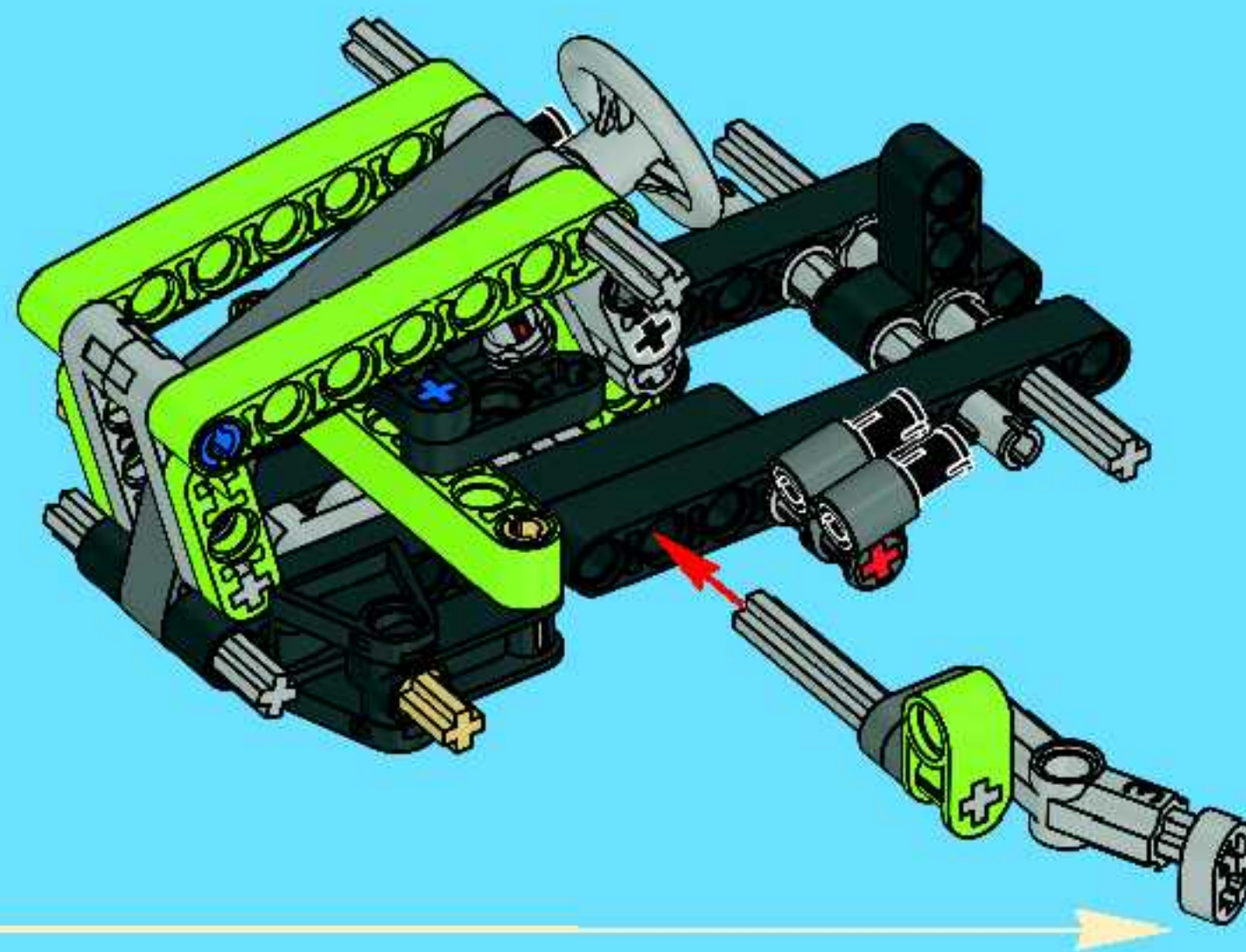



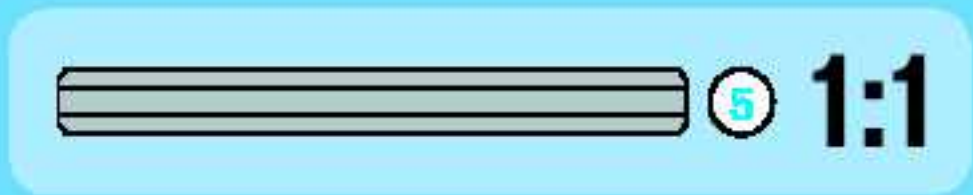
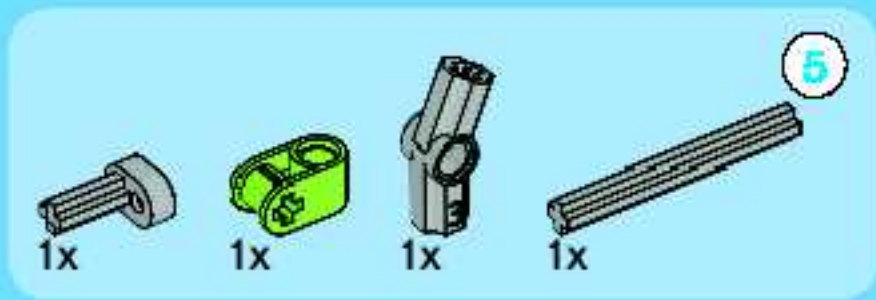

# 20

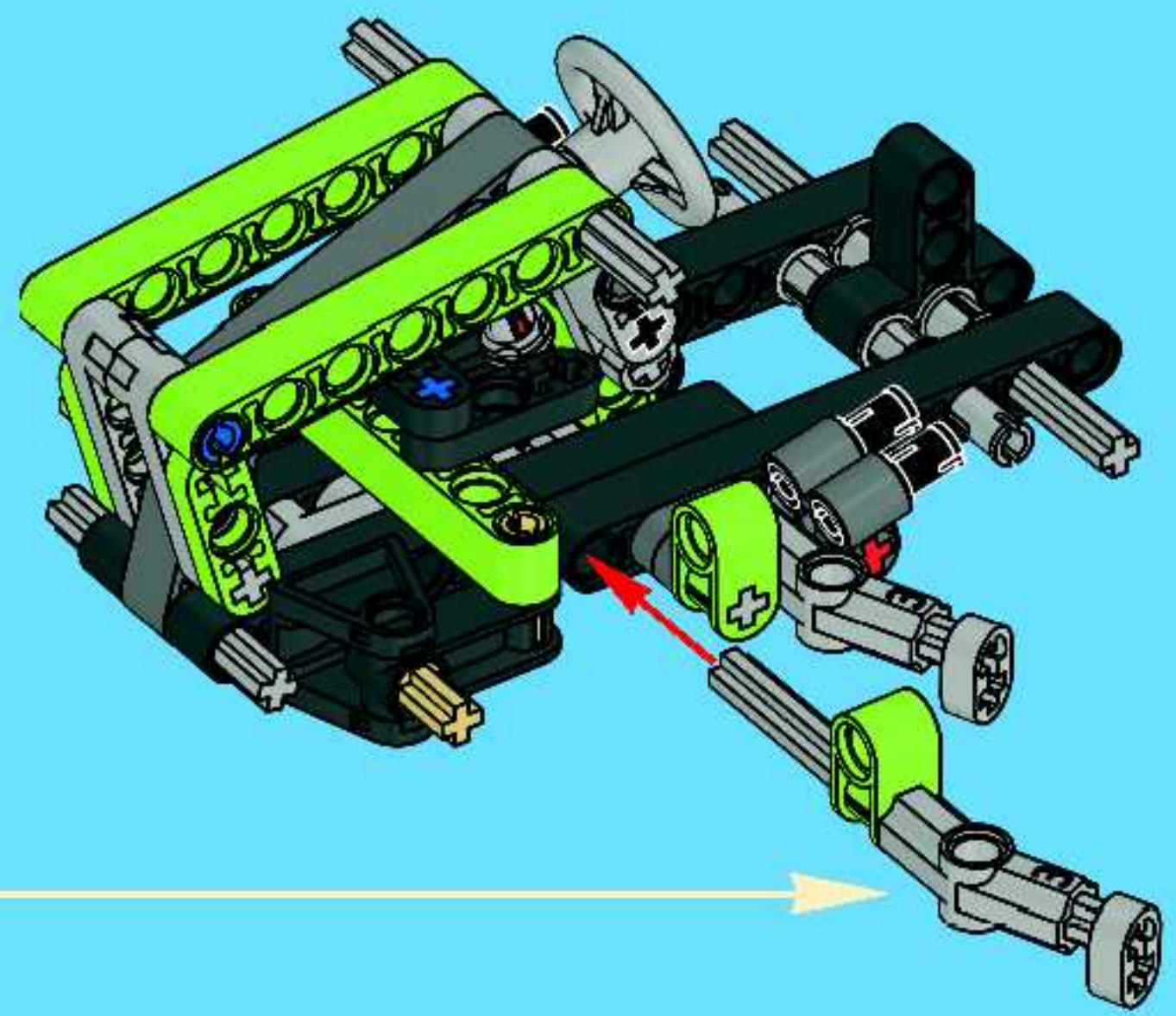
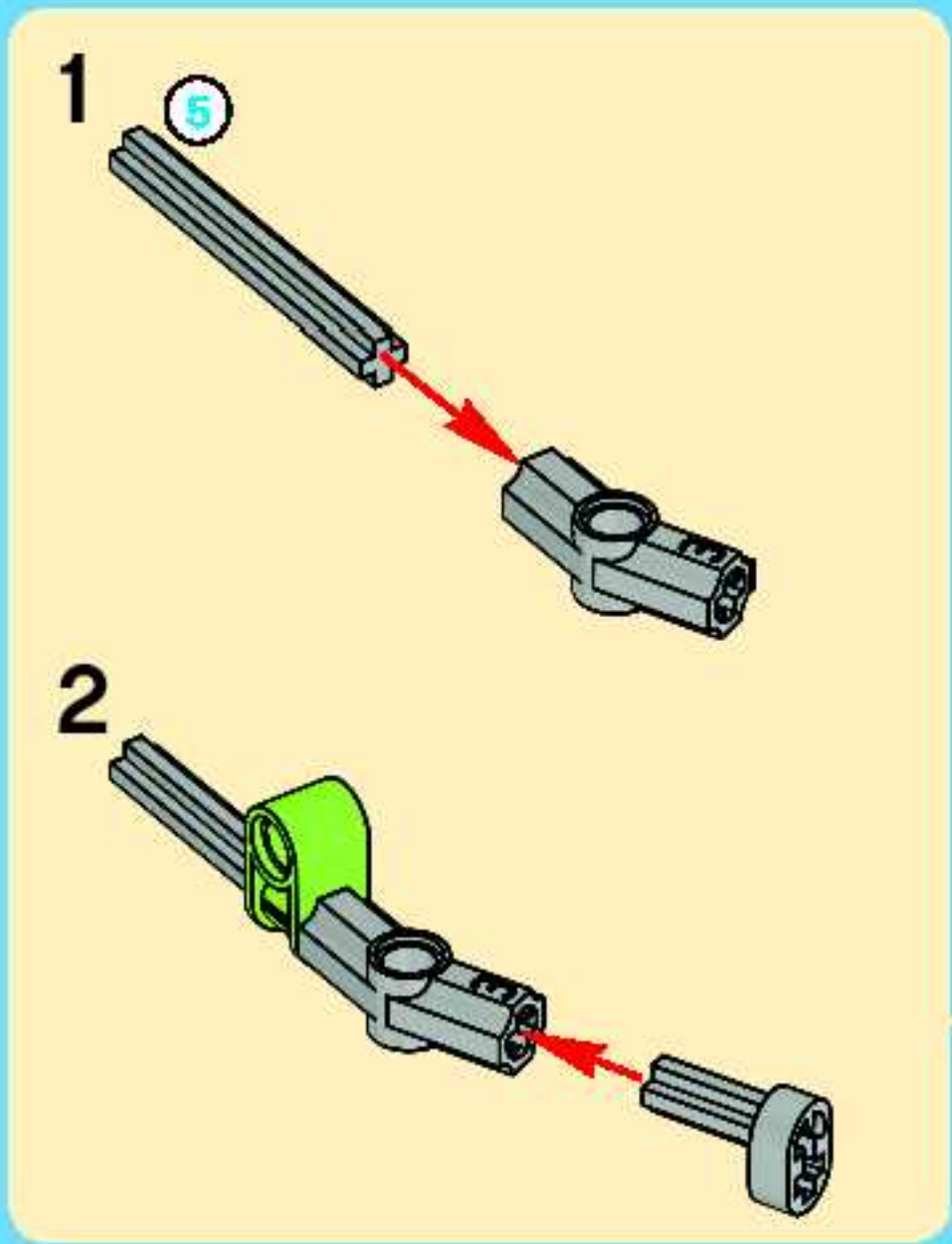



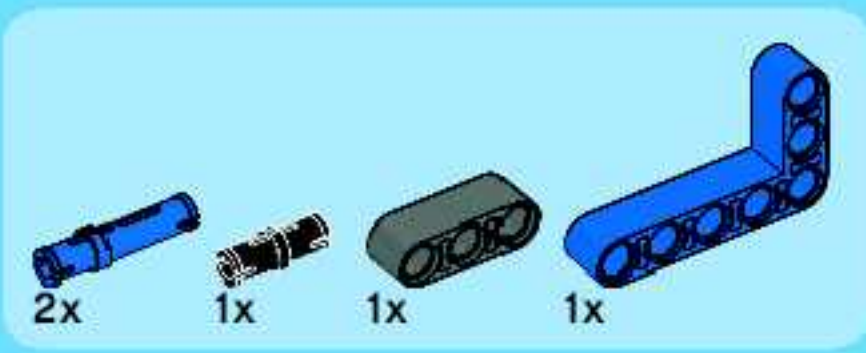

21

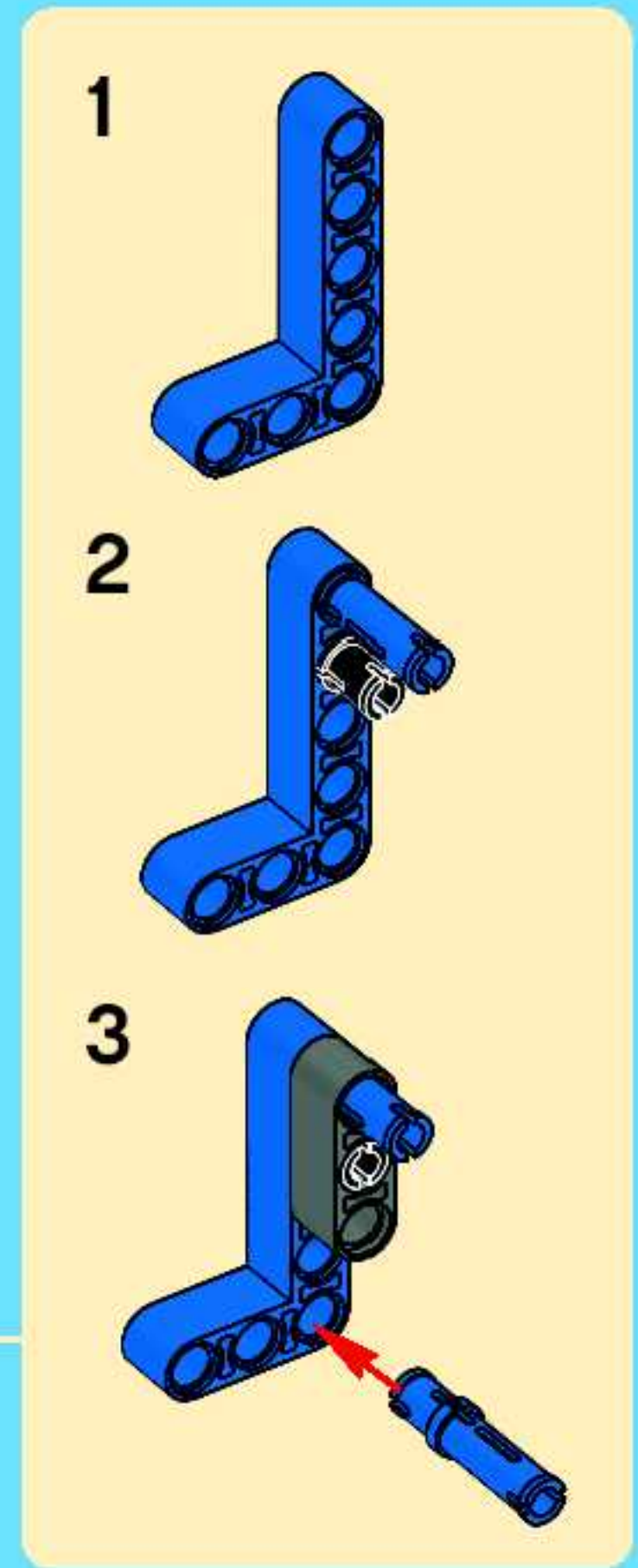
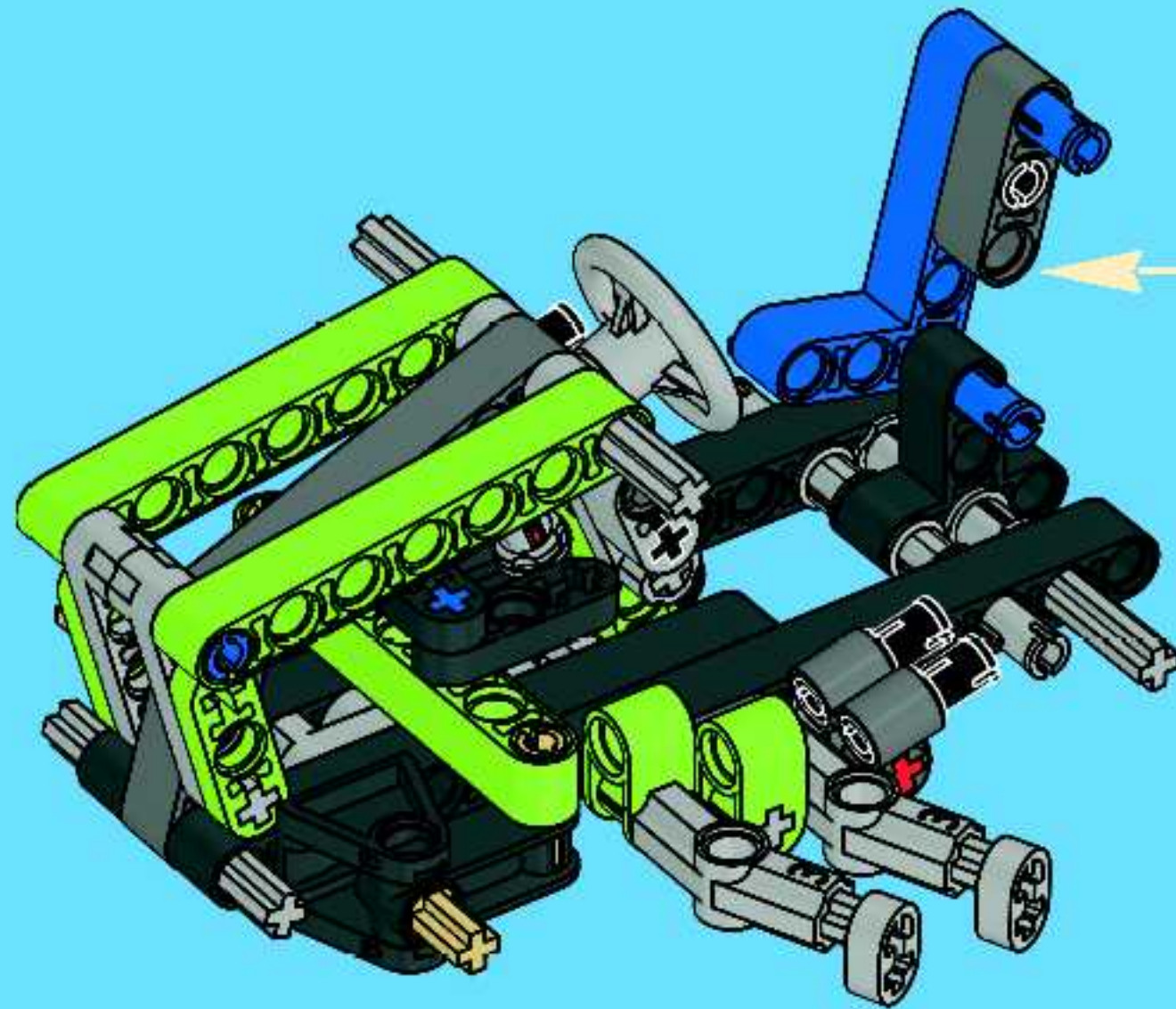



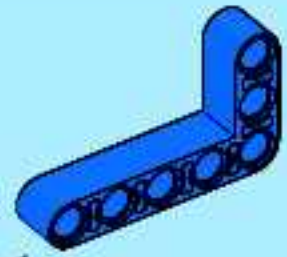

1x

22

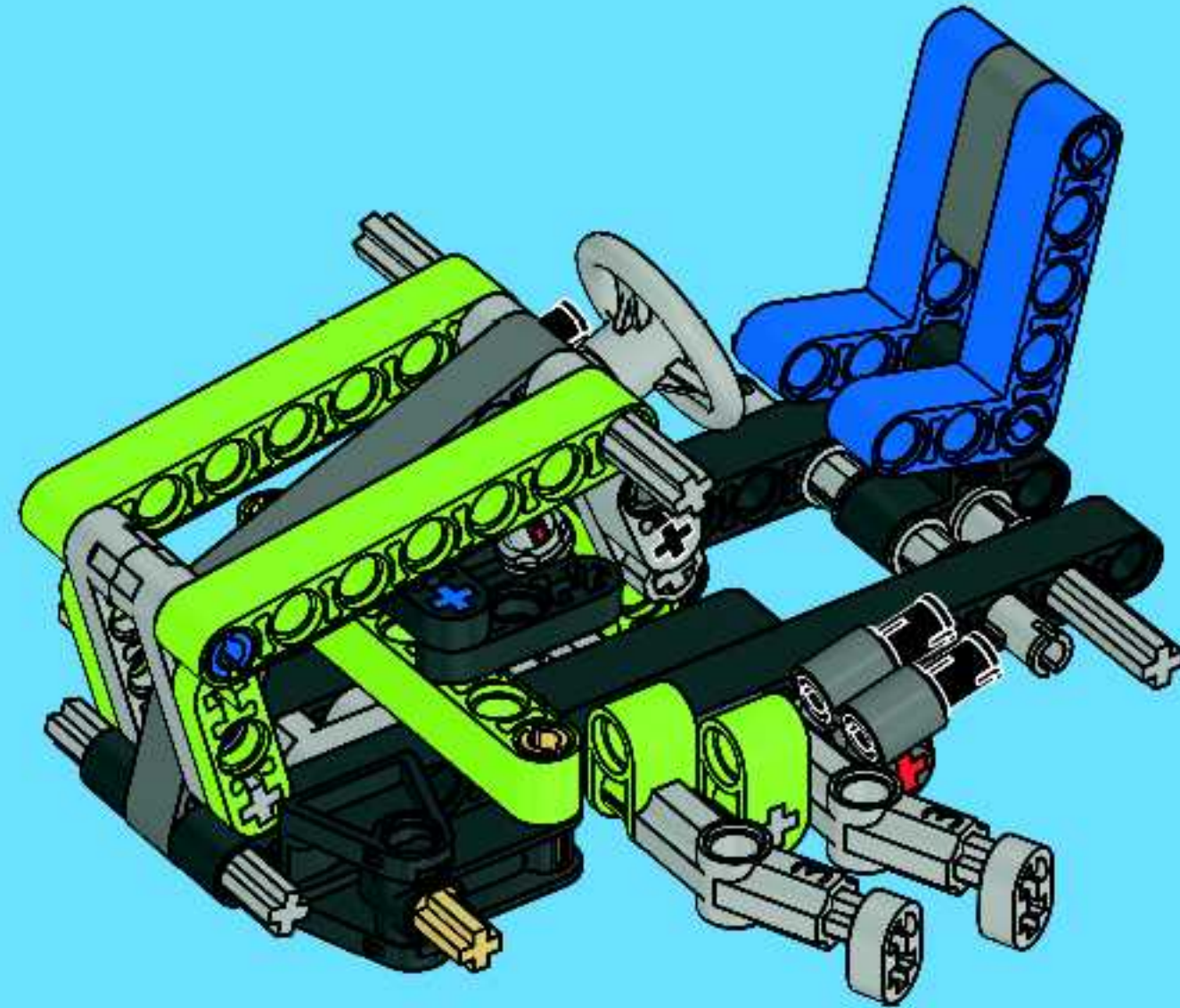



2x

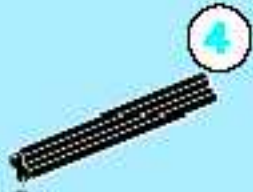

2x



1:1

23

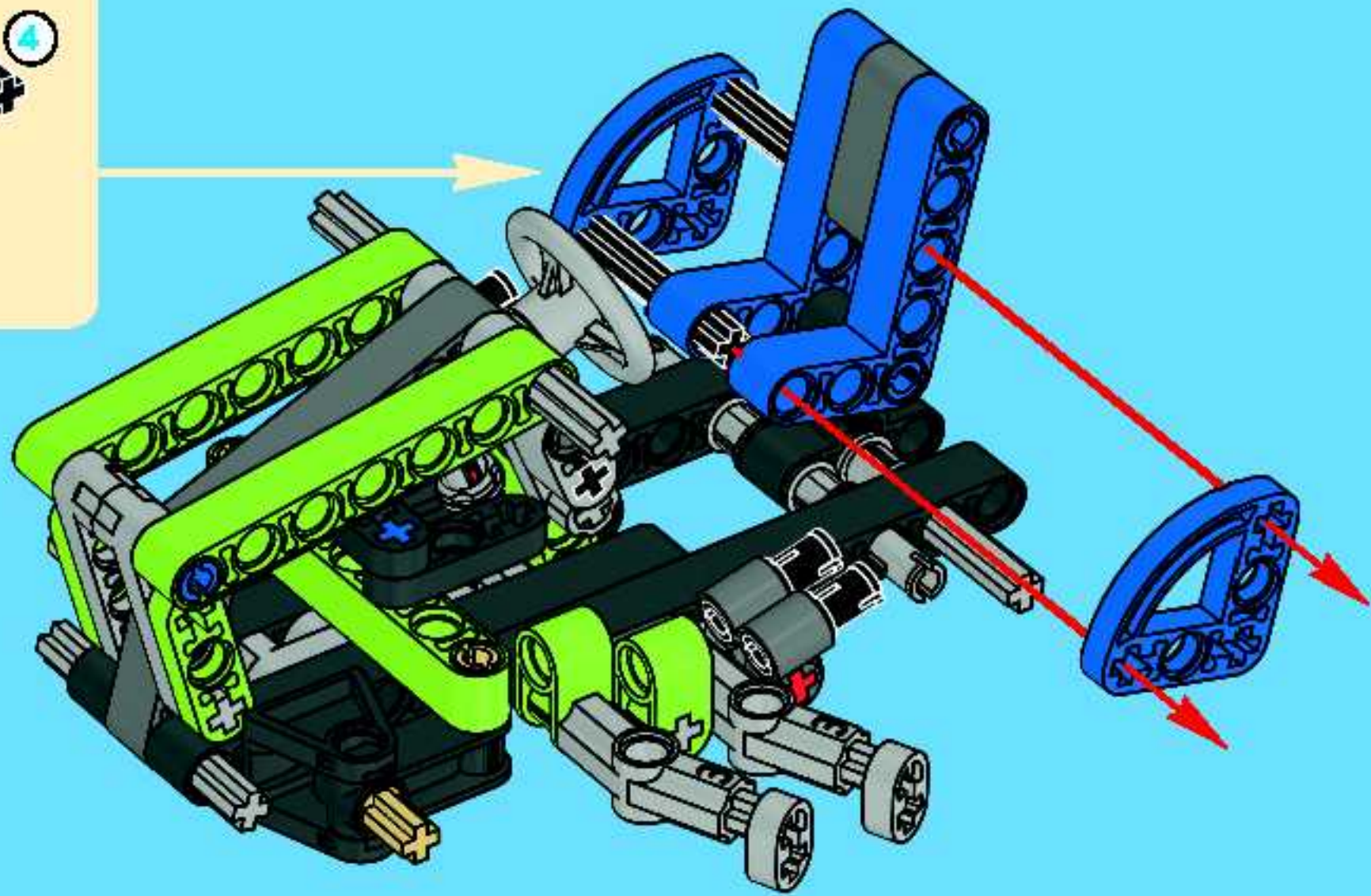





24

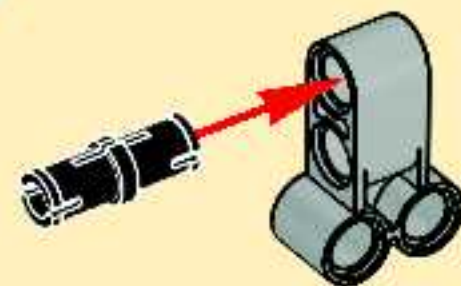
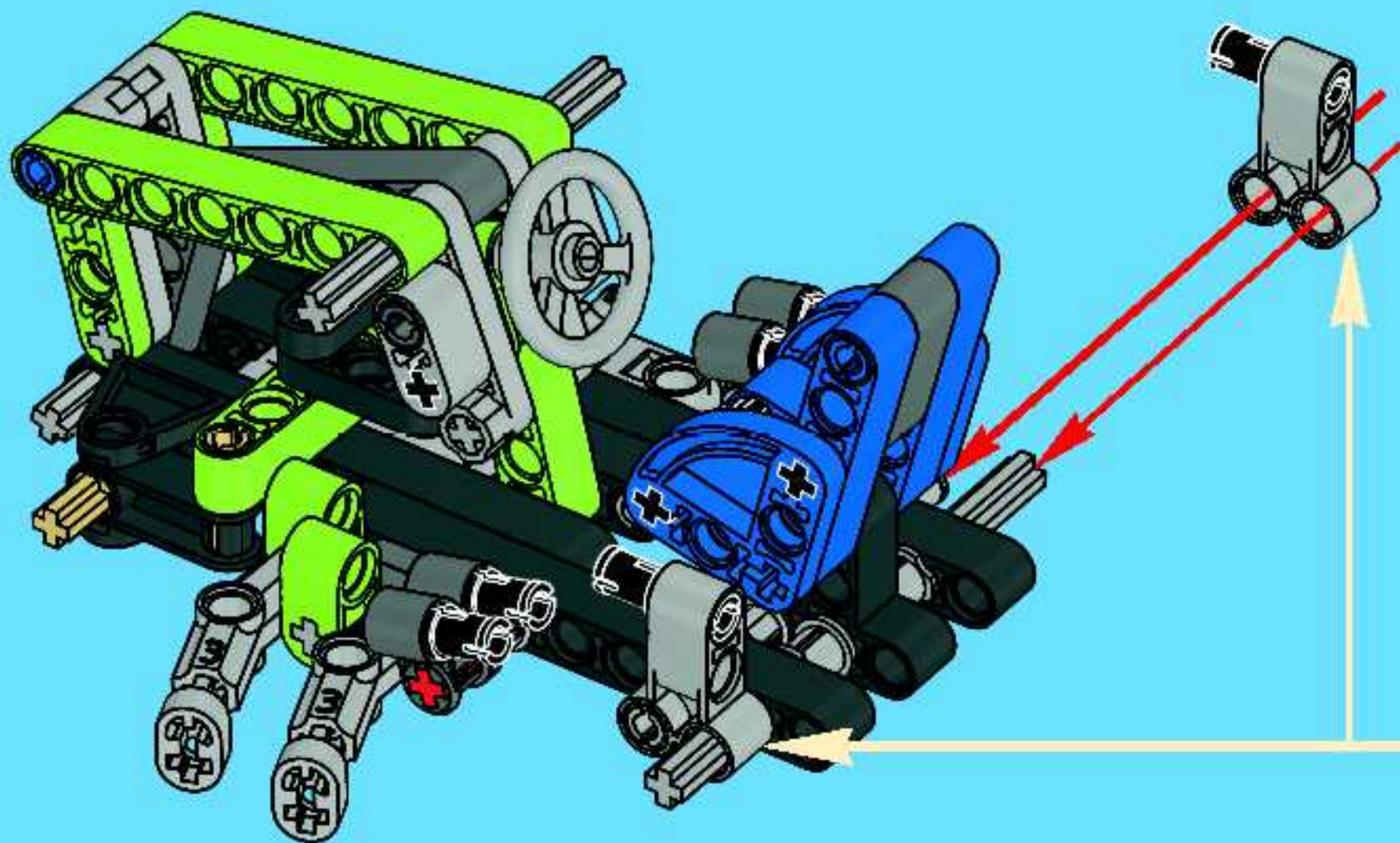

2x

6

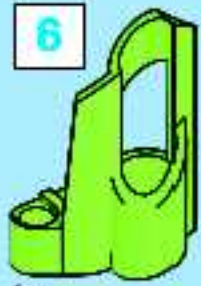

1x

5



1x

# 25

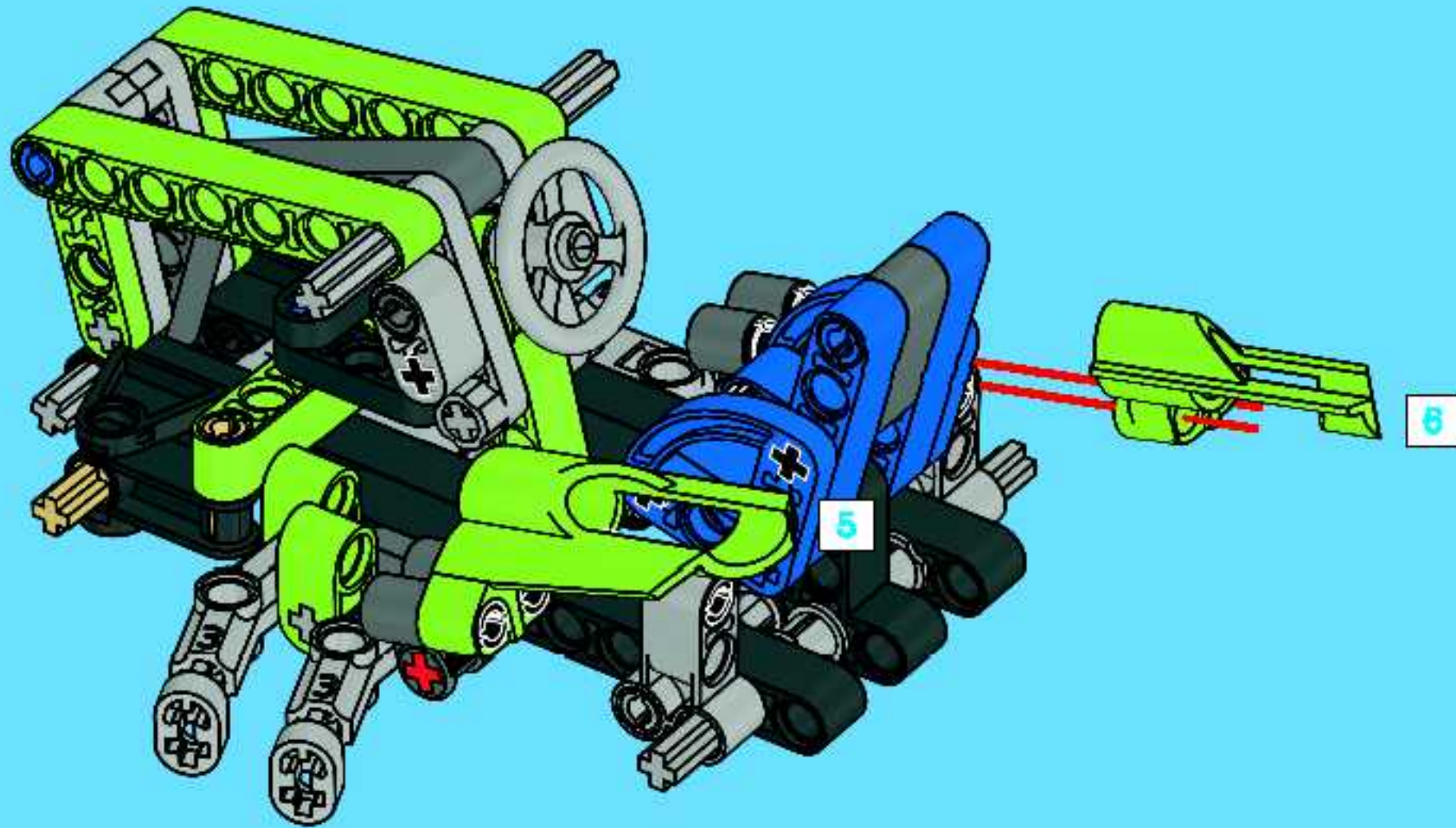





4x

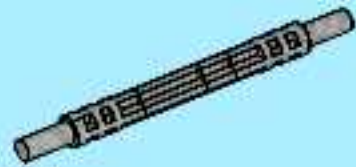

2x

# 26

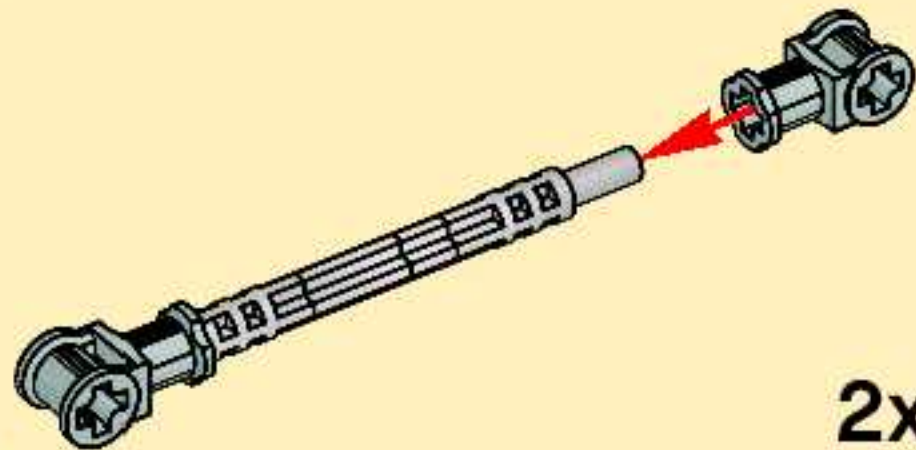

2x

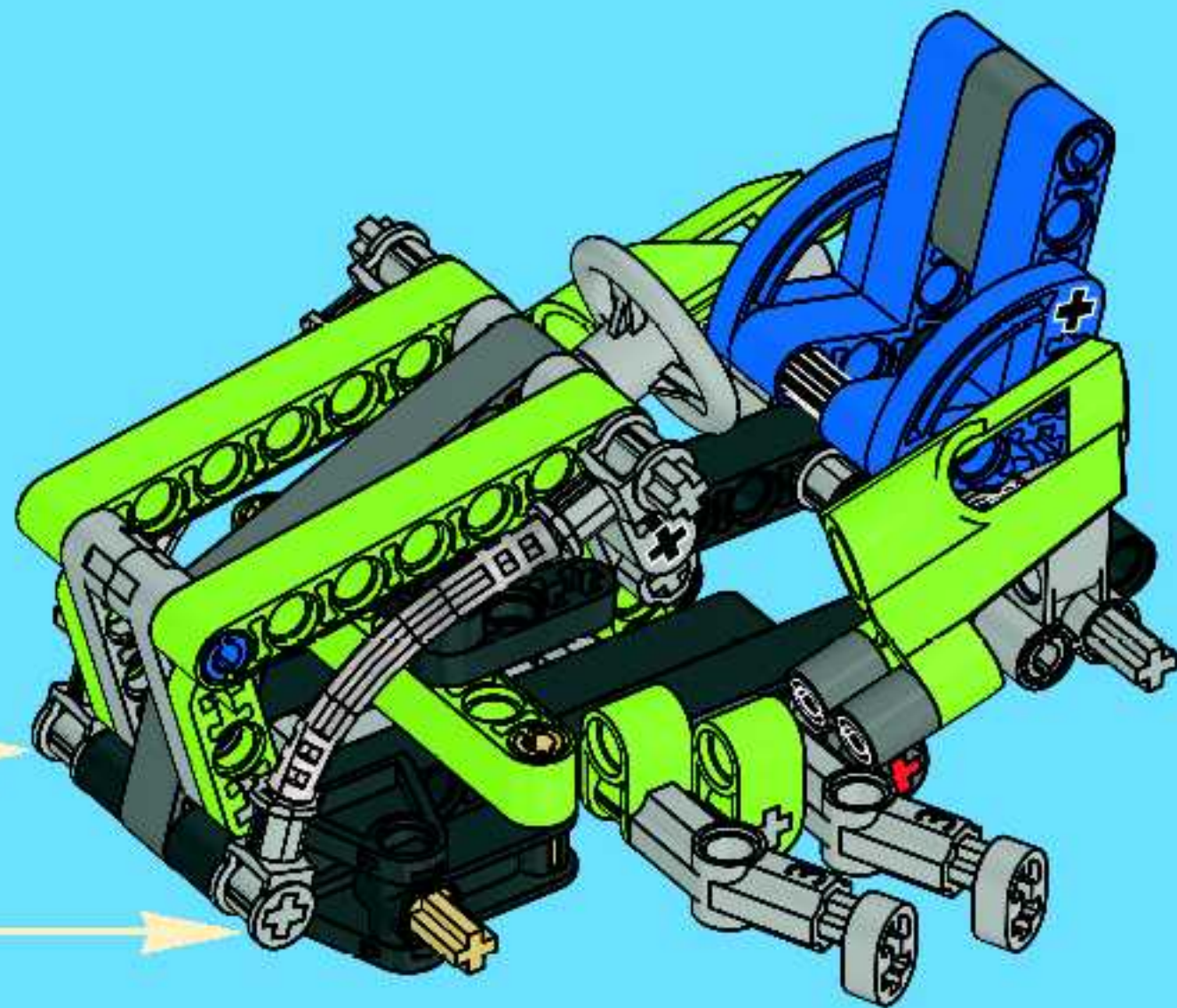

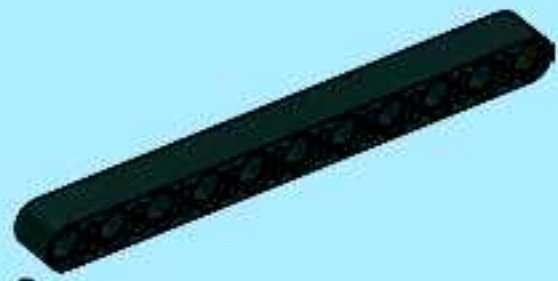

11

2x



4x



11

1:1

27

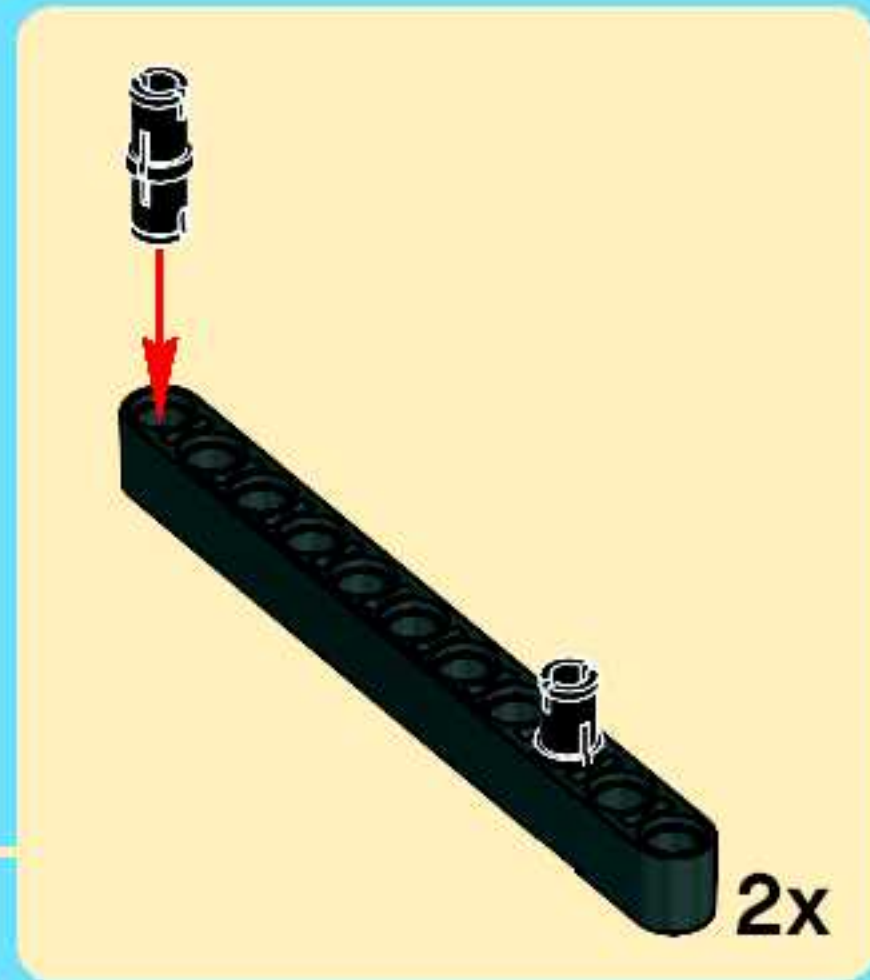
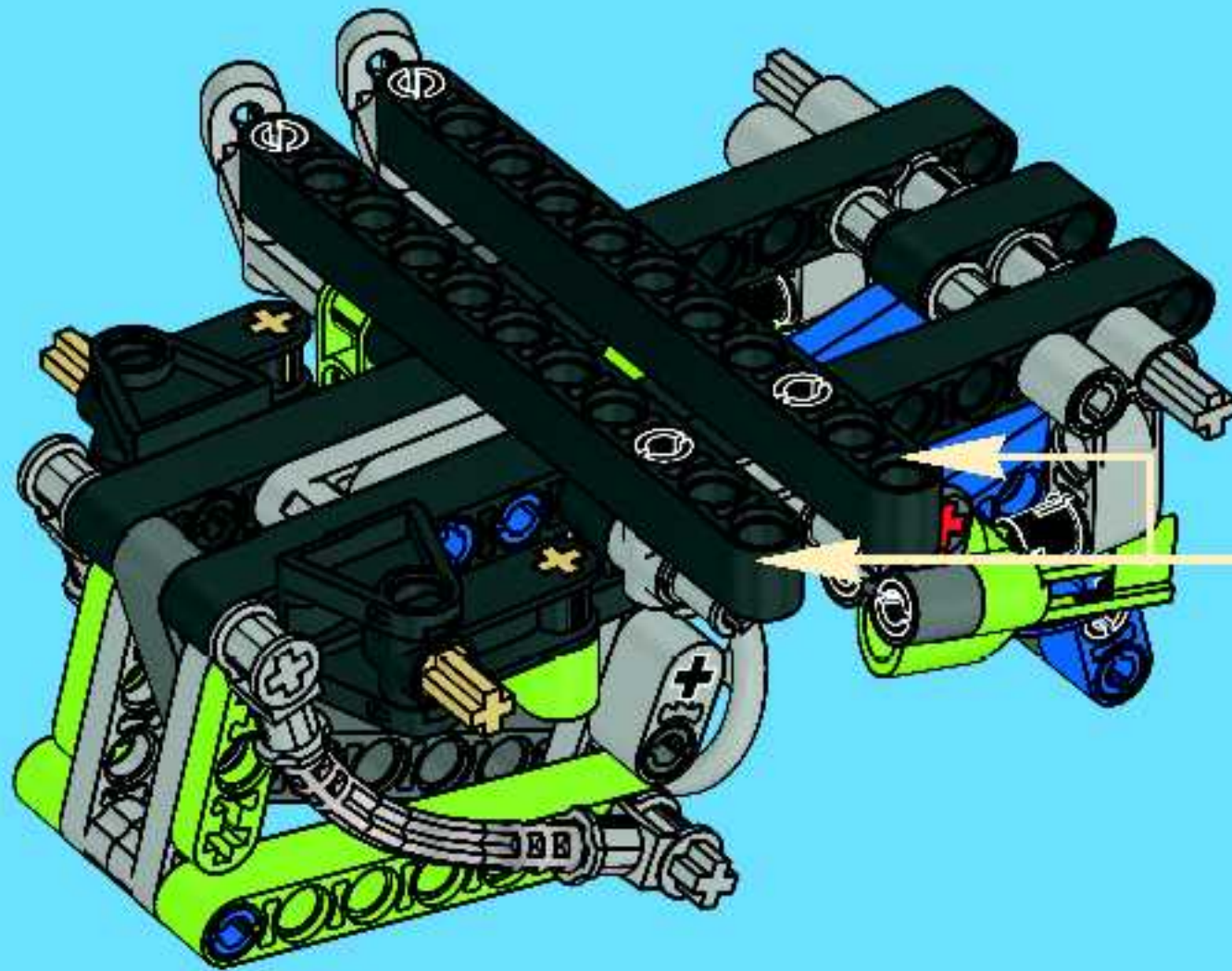

2x



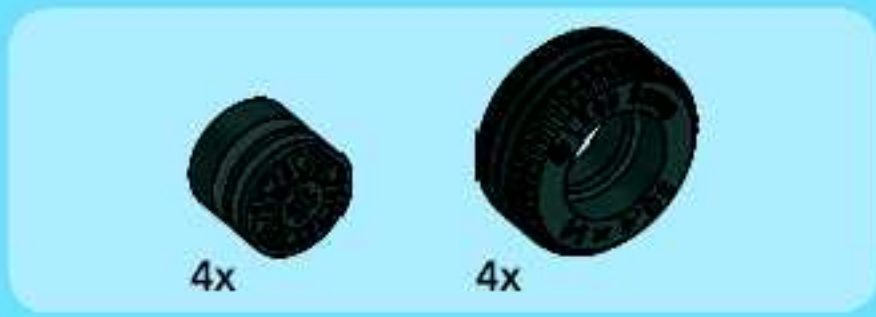

28

