



# HEROFACTORY



2282

# ROCKA XL

1

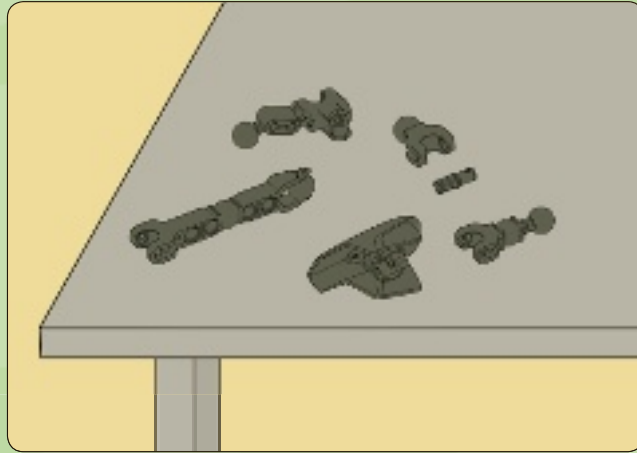
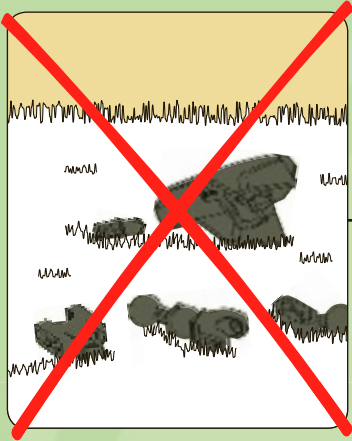

2

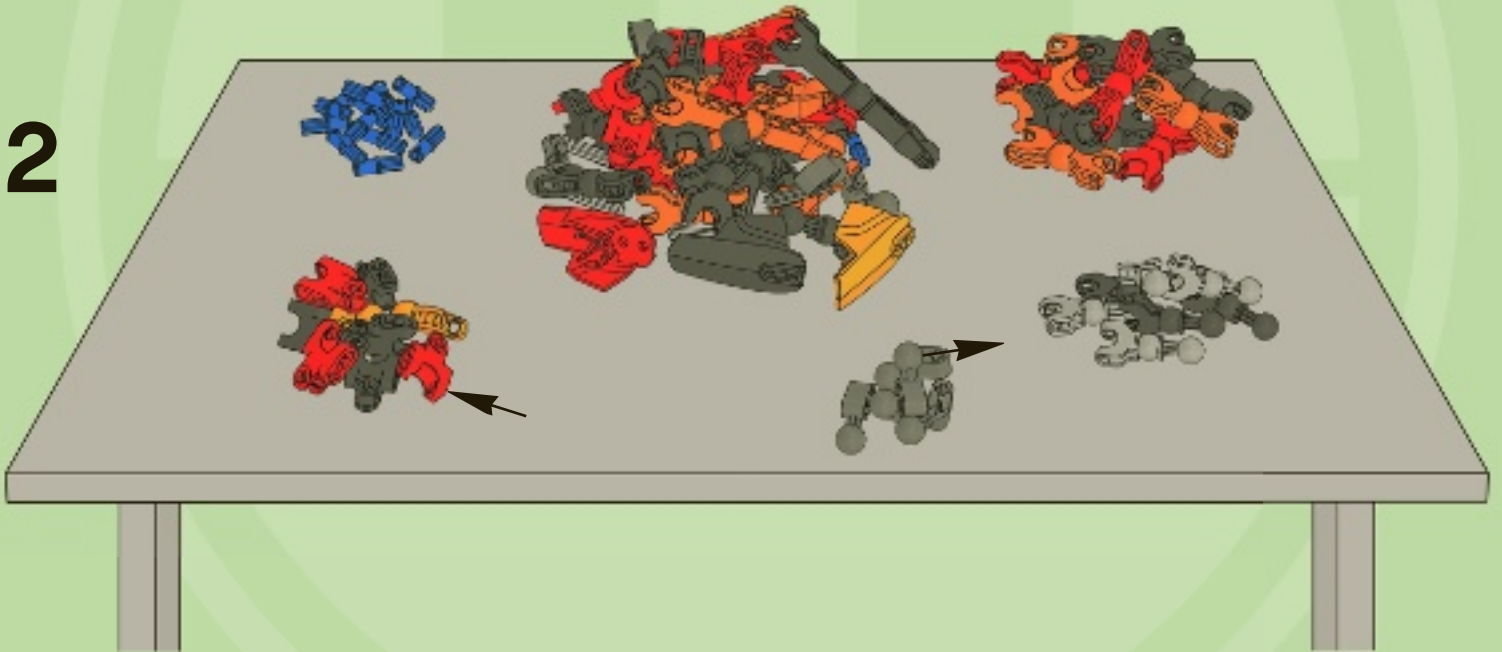



4
1:1

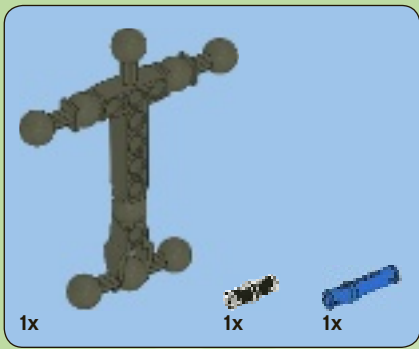

5
1:1

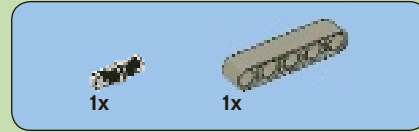
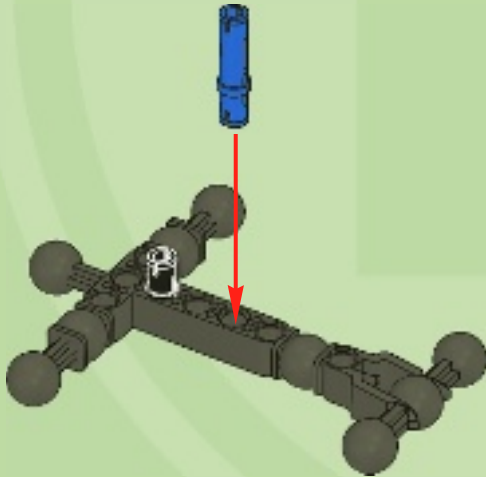

1

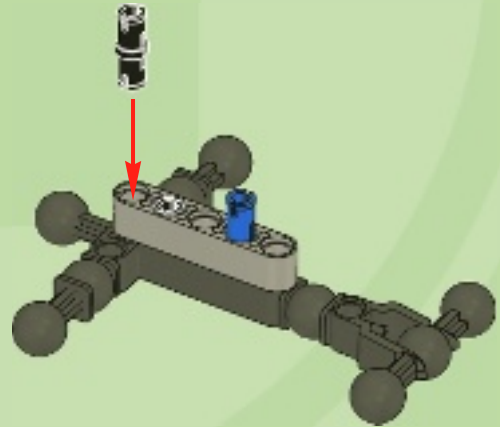

2





2x

3

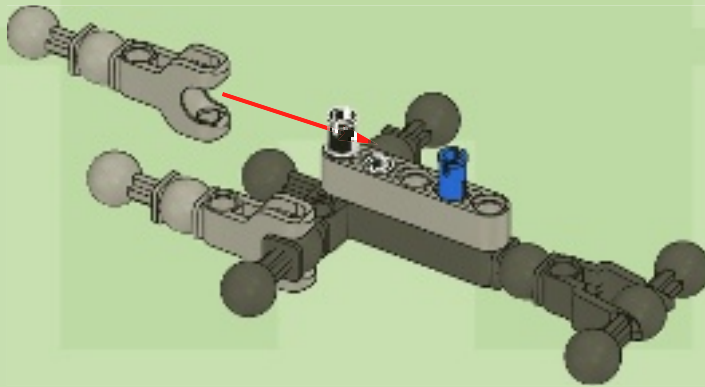

4

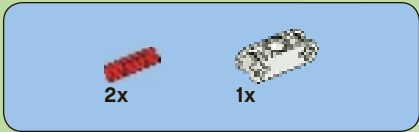

1

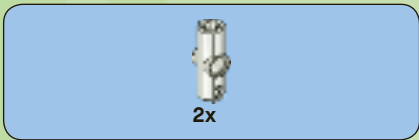
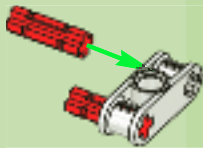

2

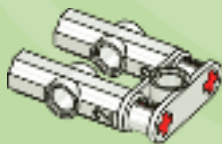

3

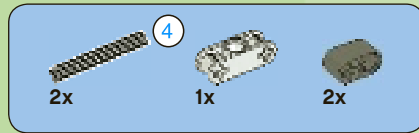
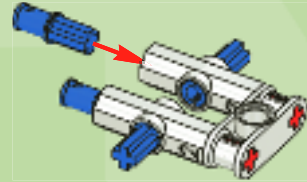

4

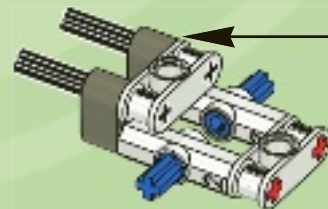
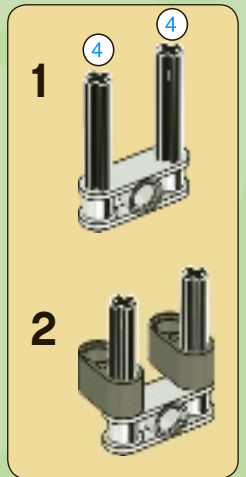

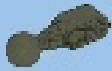

2x

5

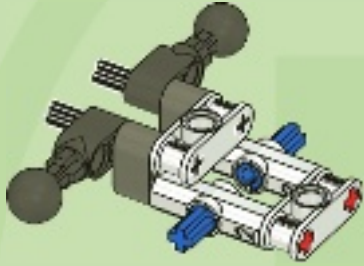

1x

6

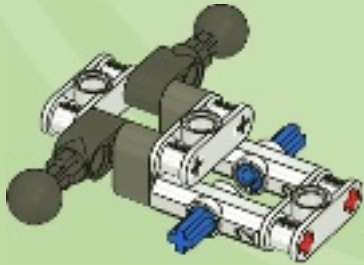

4

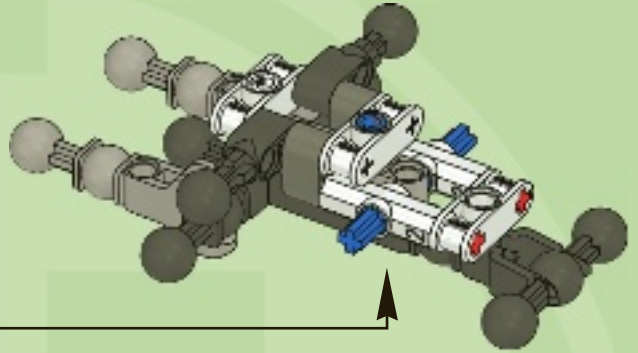

2x

5

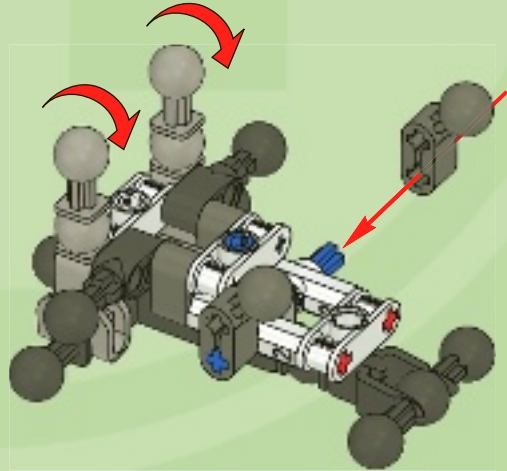



2x

# 6

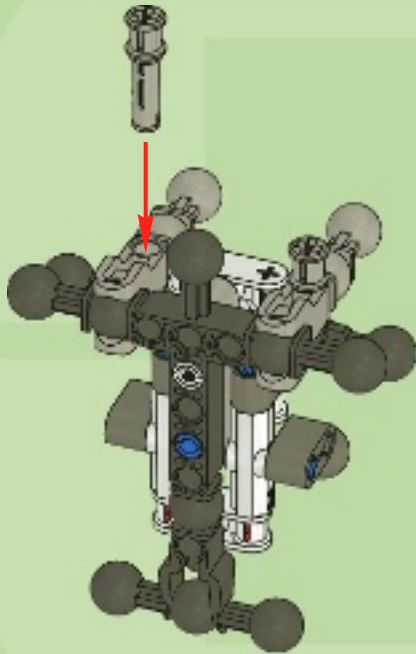

2x



2x

# 7

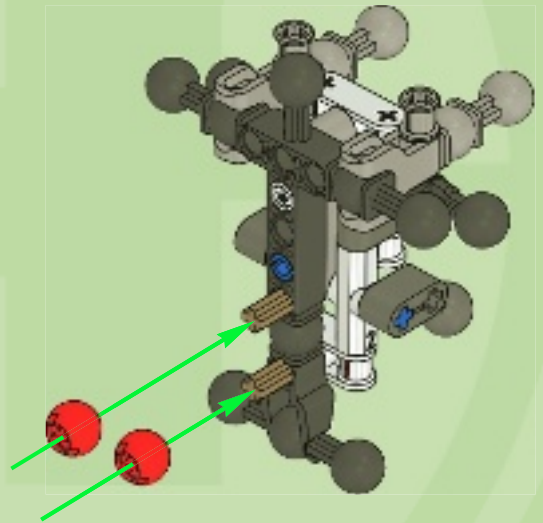



8

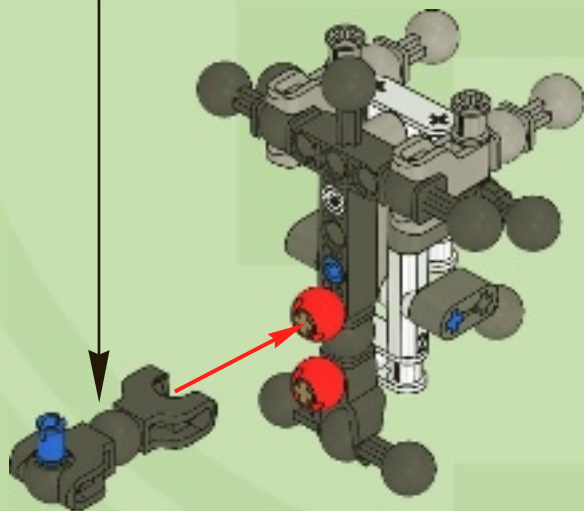

9

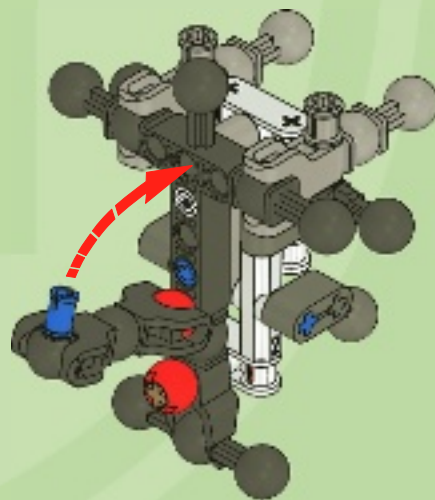



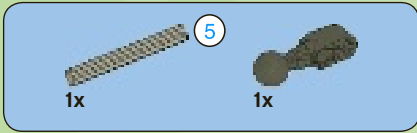

1

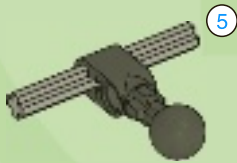
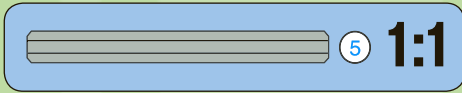

2

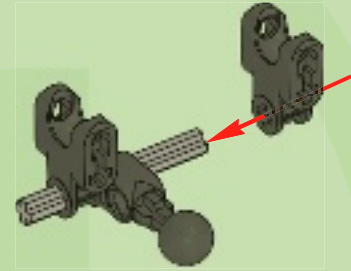

3

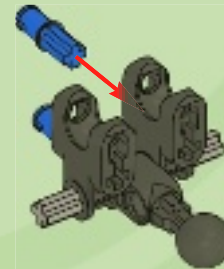

2x

4

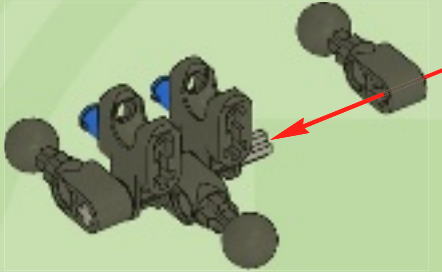

2x

6

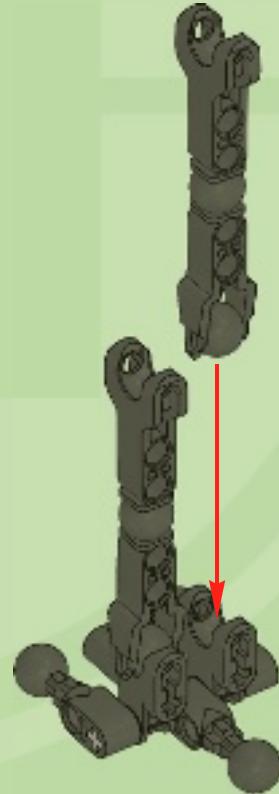

2x

1x

5

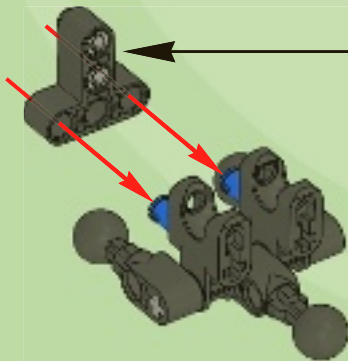
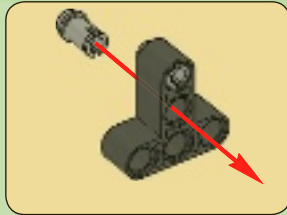



7

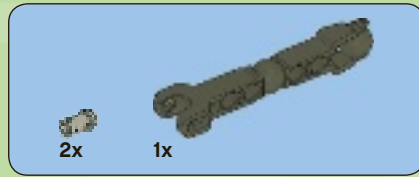
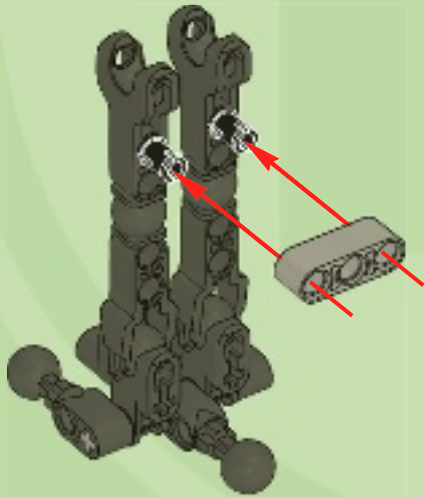

8

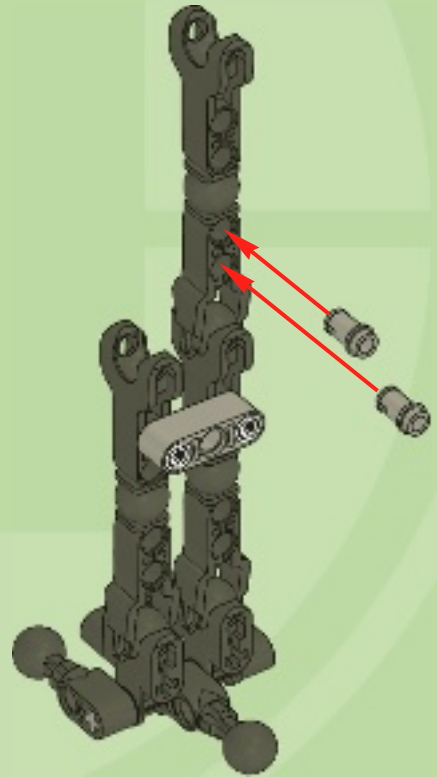



9

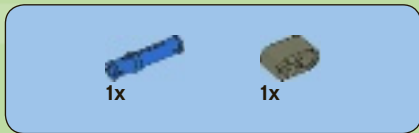
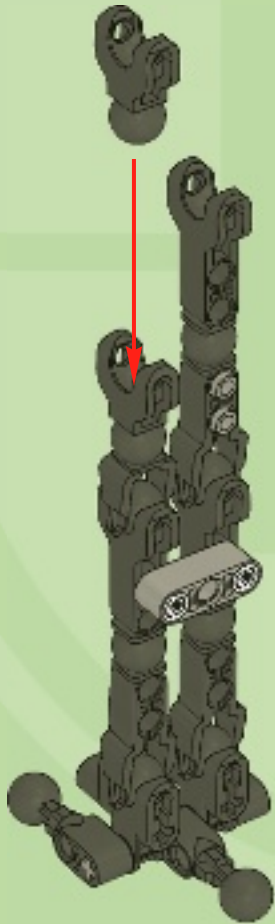

10

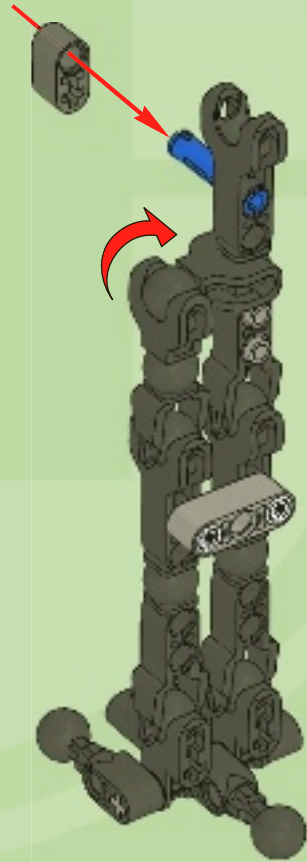



11

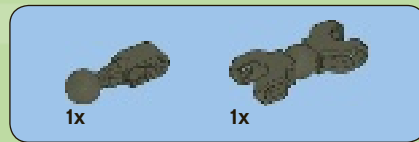
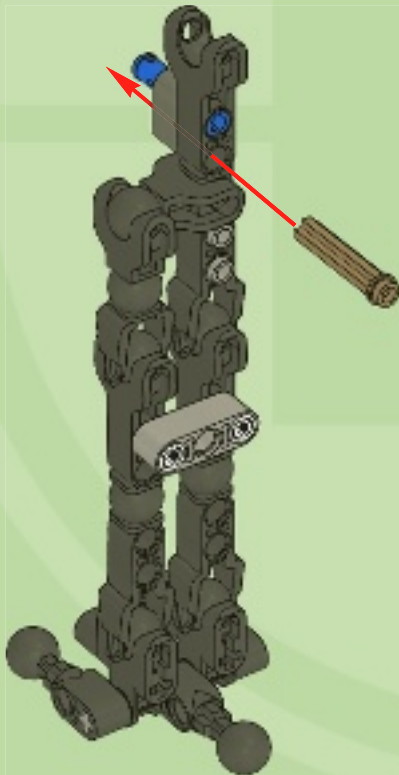

12

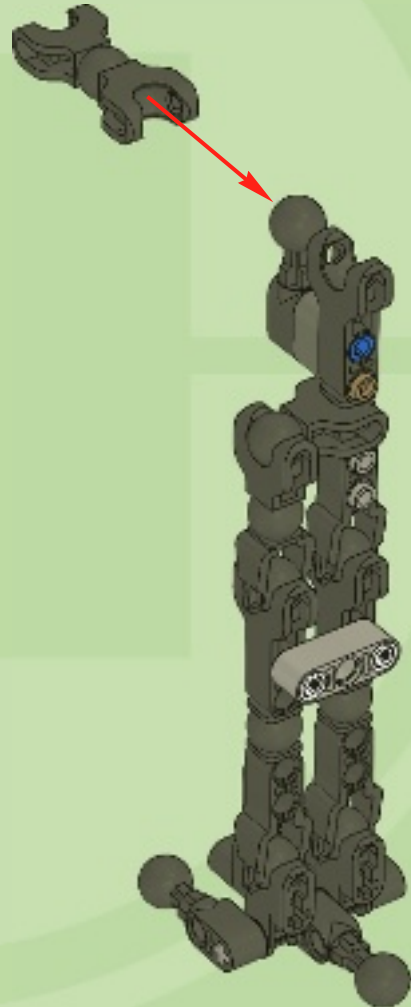



13

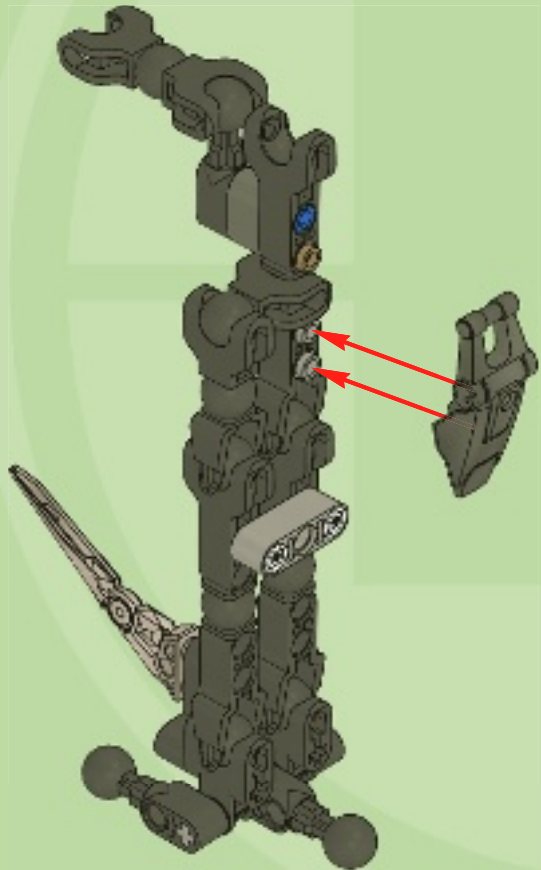

14

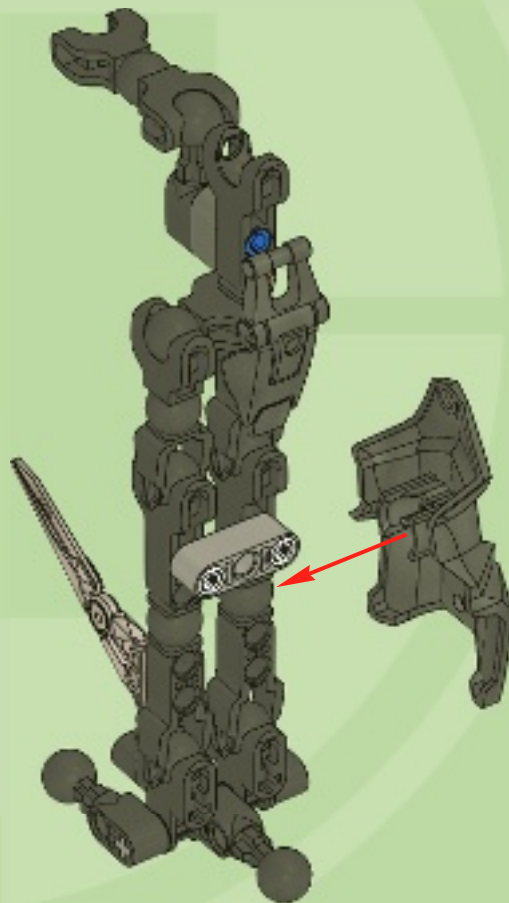

10

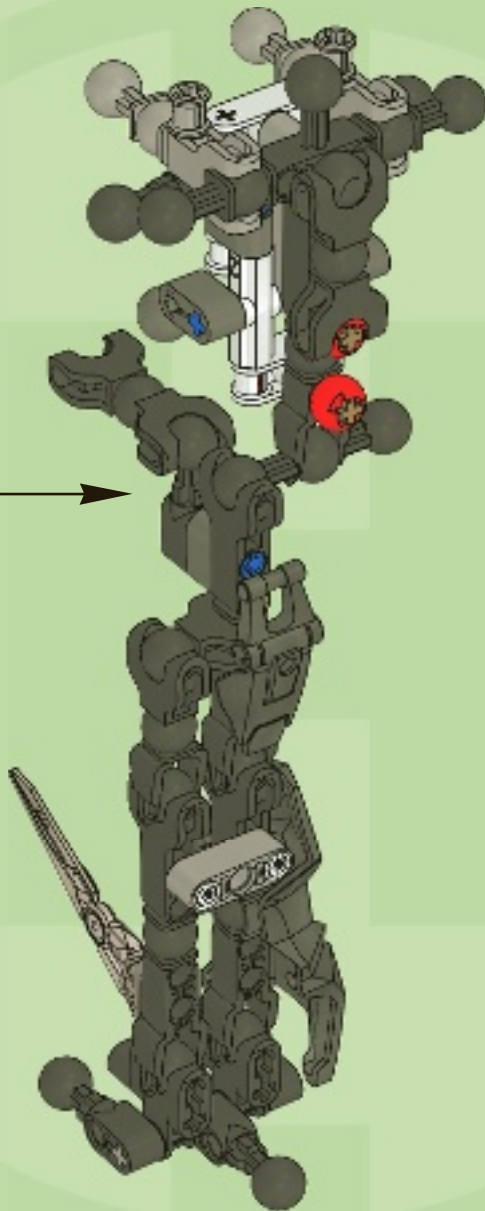



1

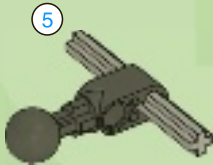

2

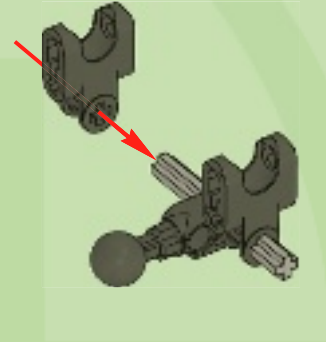

3

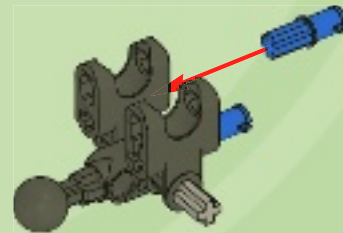



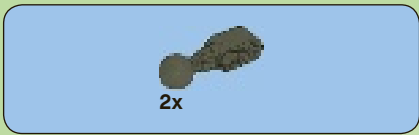

4

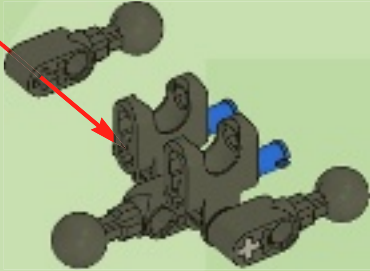

5

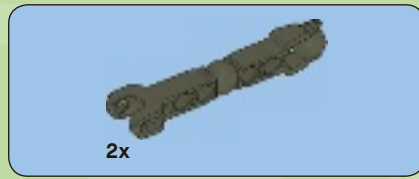
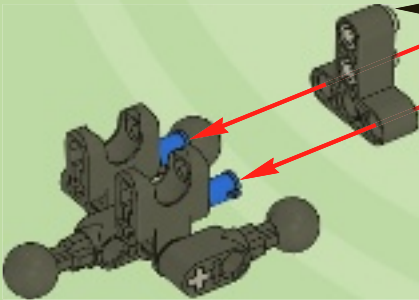
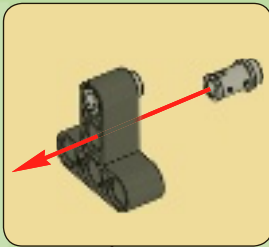

6

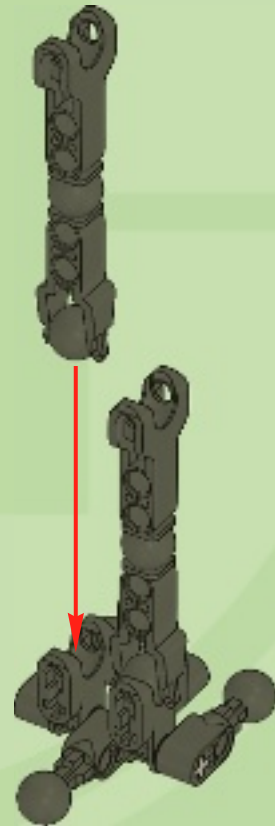

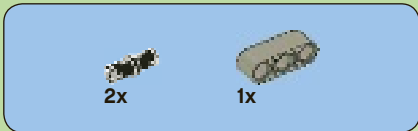

7

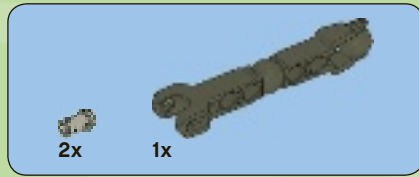
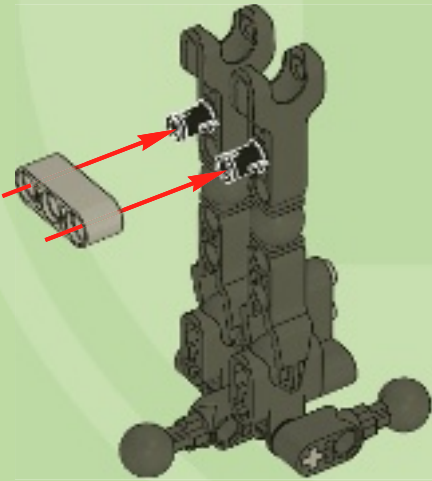

8

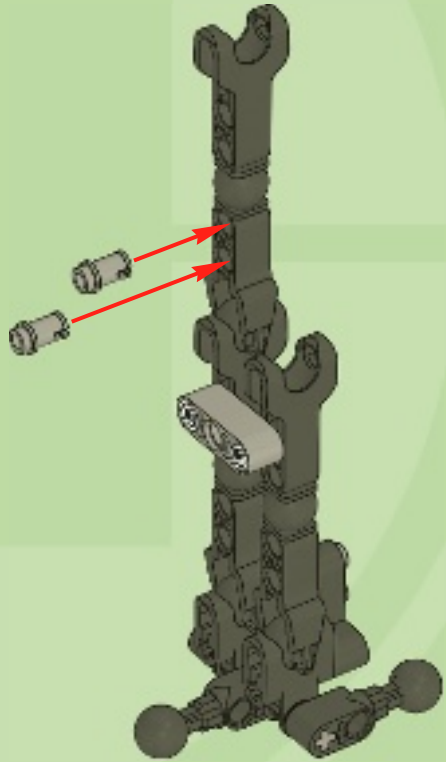



9

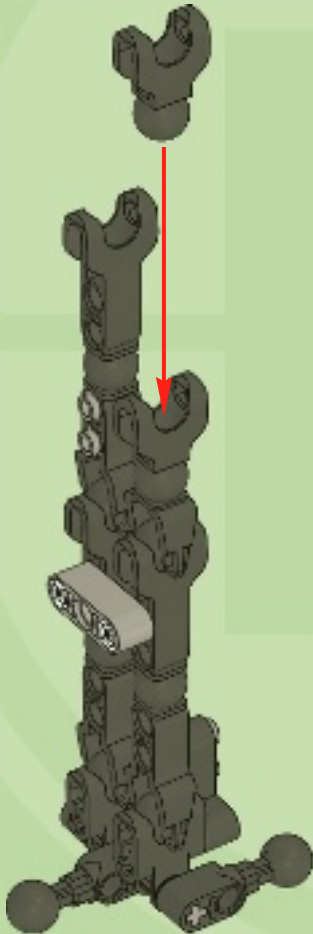

10

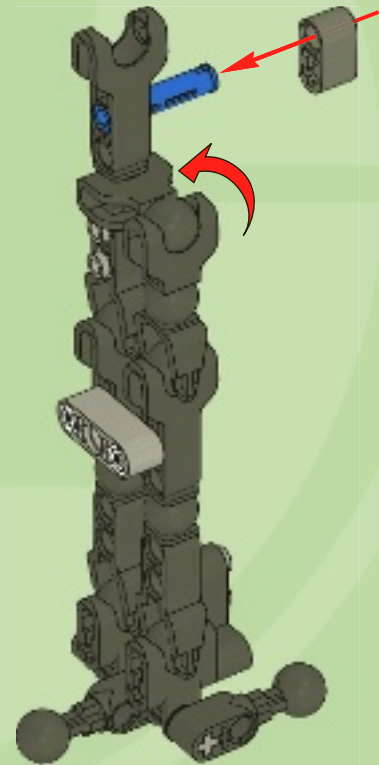



1x

11

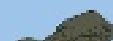
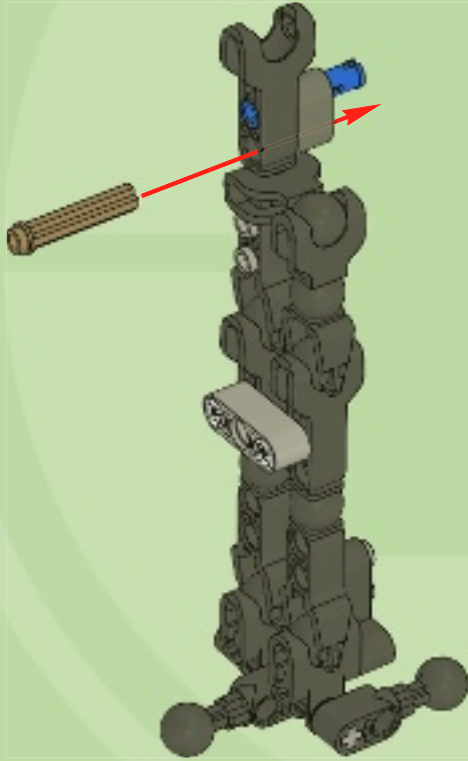

1x



1x

12

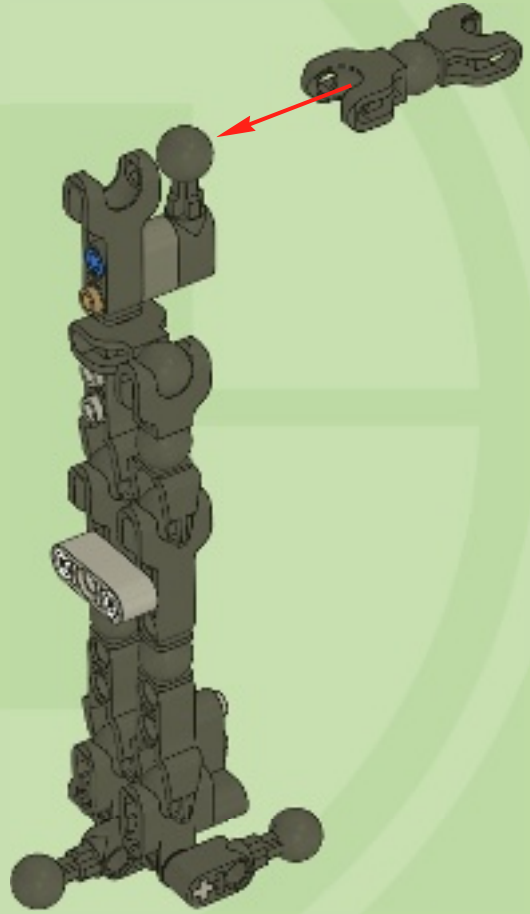



13

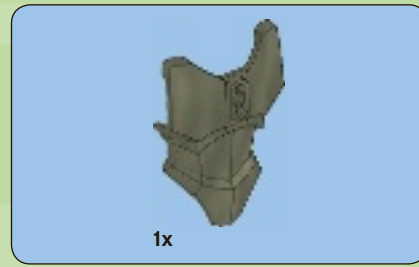
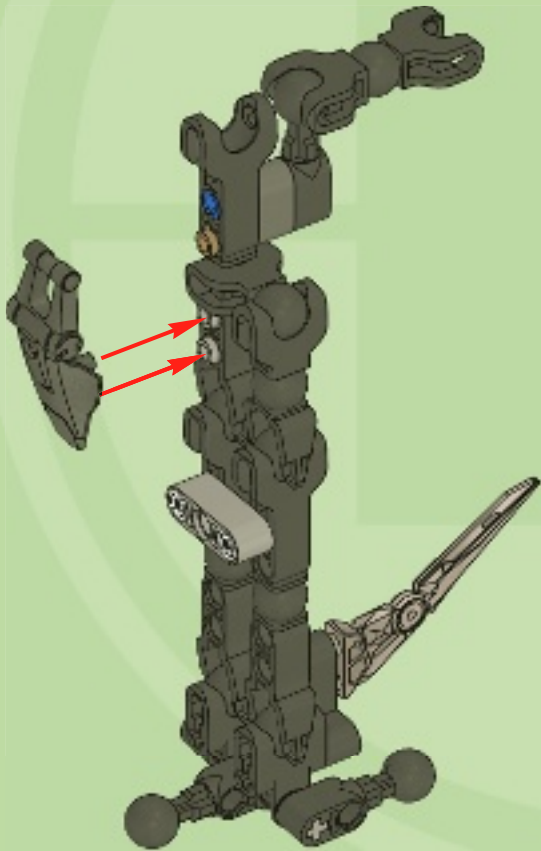

14

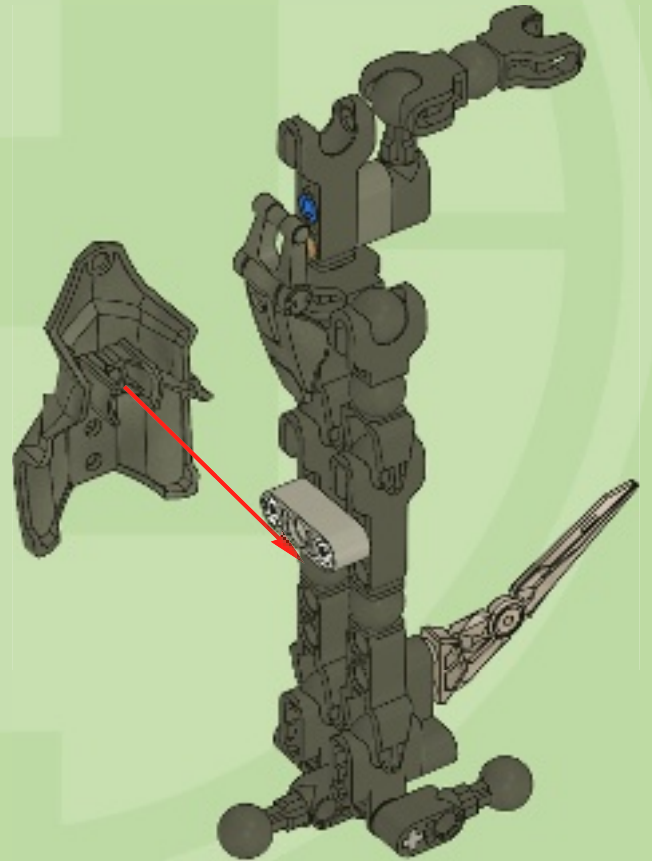

11

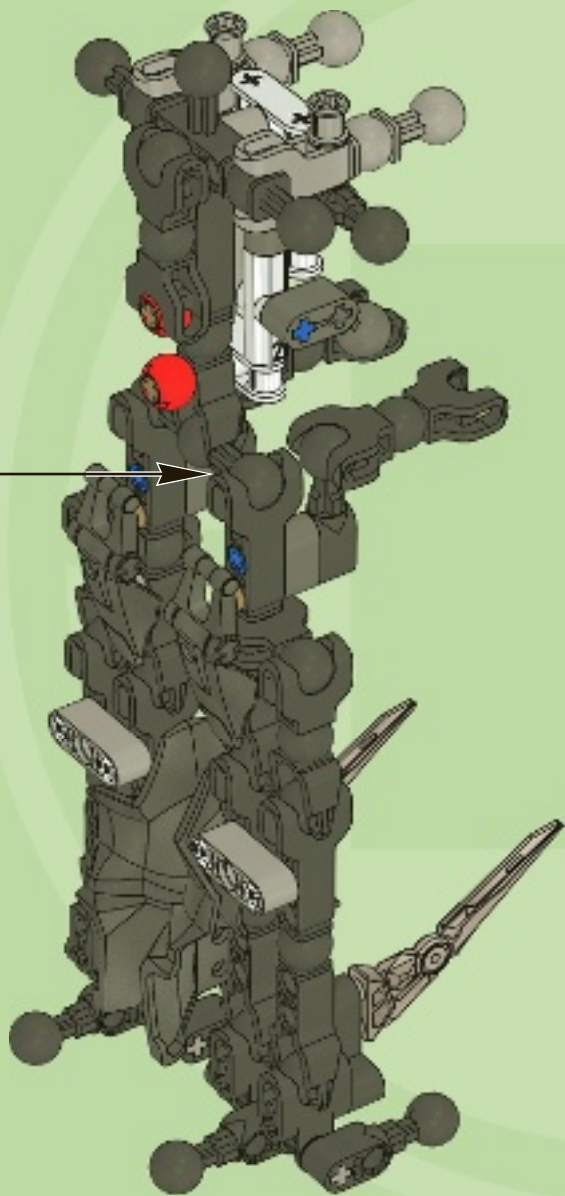

12

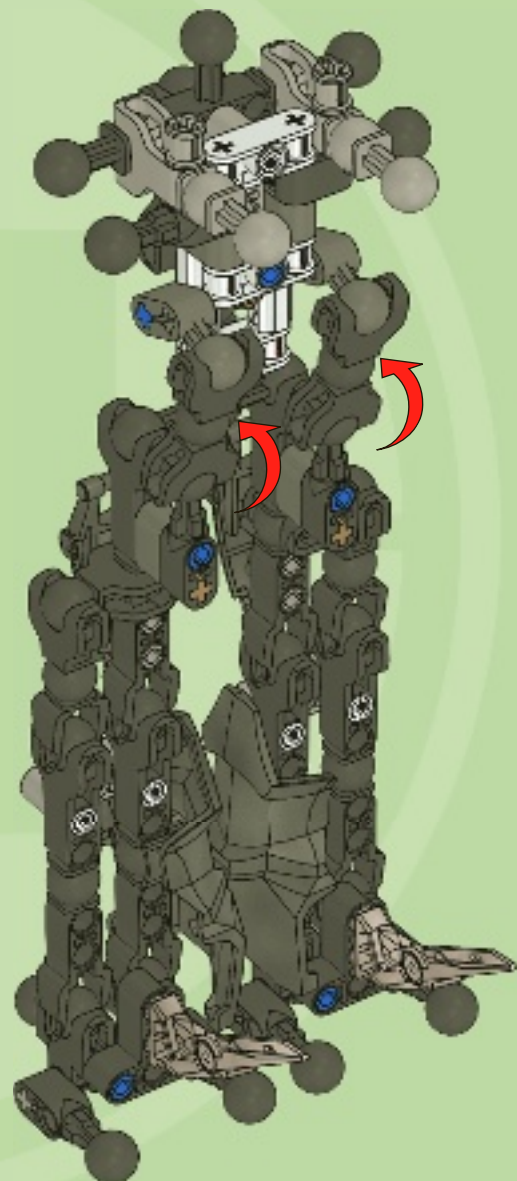



1

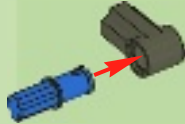

2



3

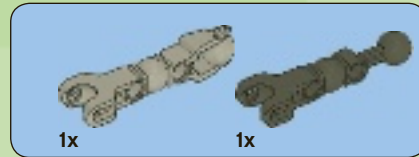
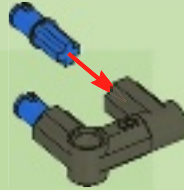

4

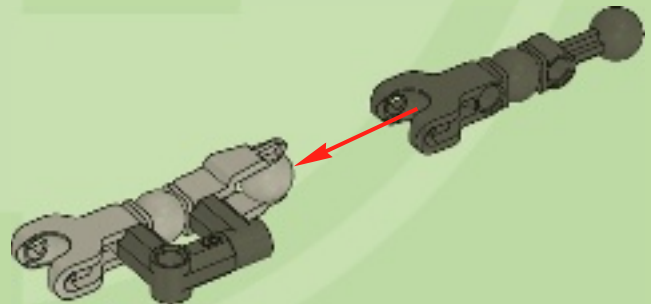



5

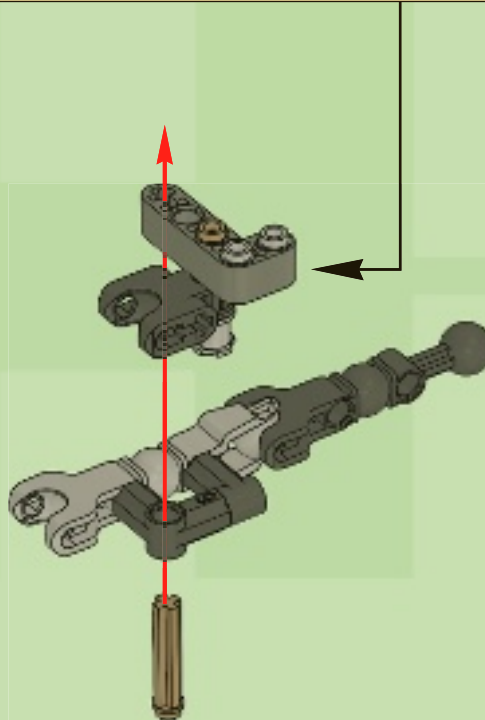
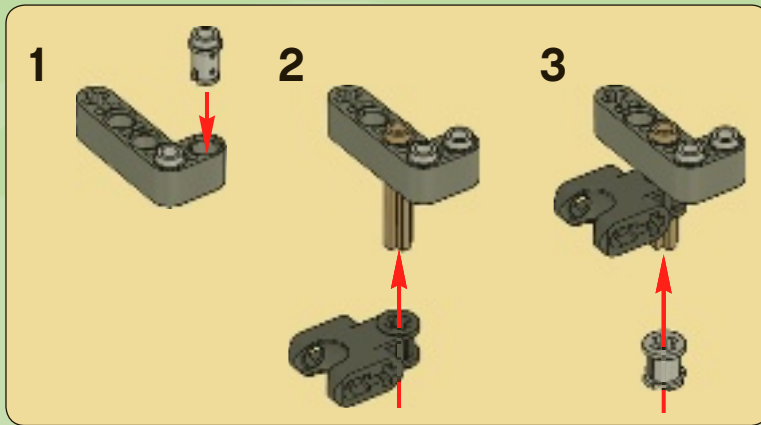





1x

6

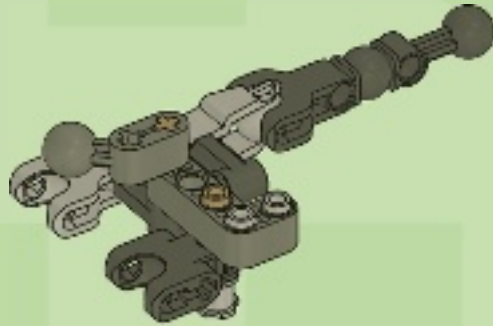

1x

7

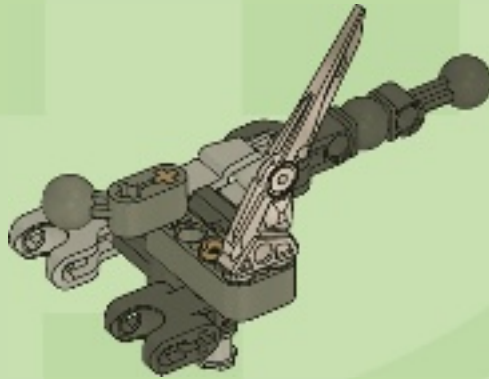

13





1

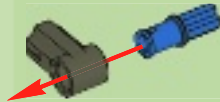

2



3

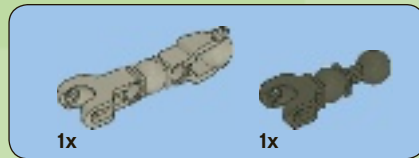
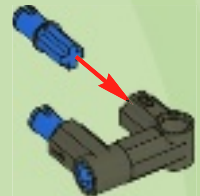

4

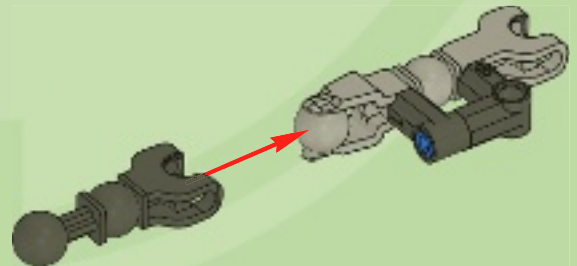

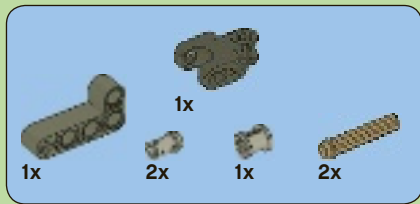

5

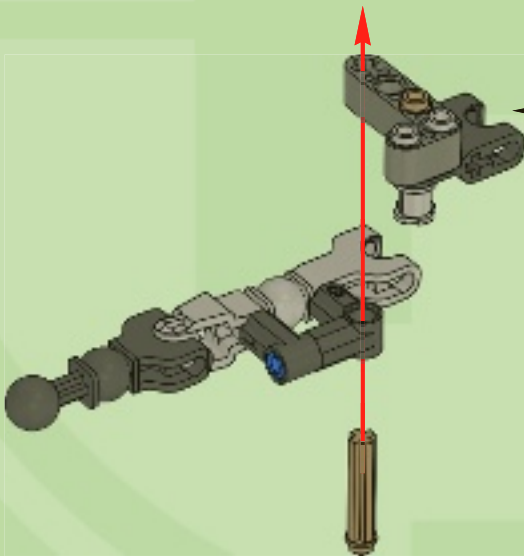
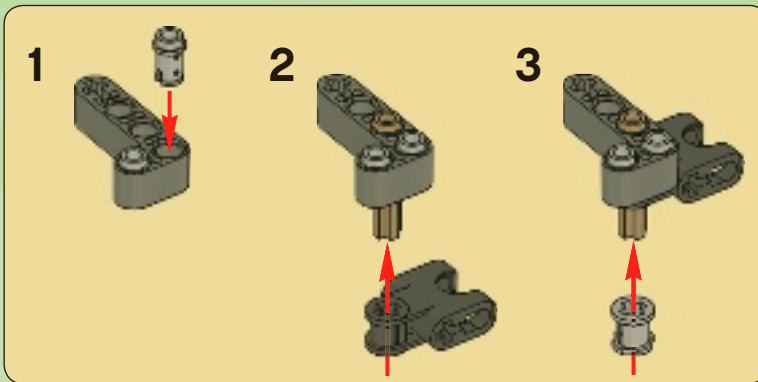



1x

6

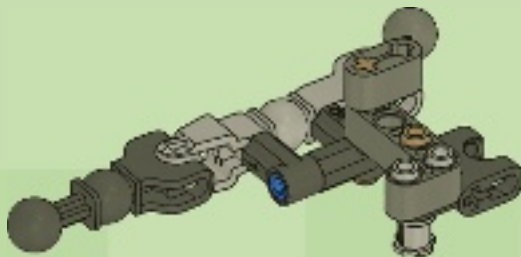

1x

7

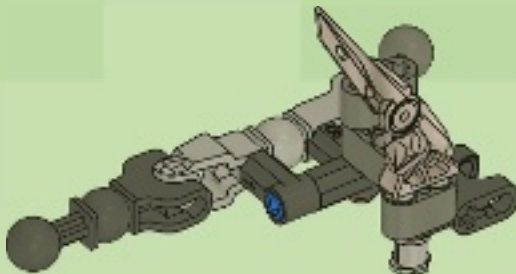

14

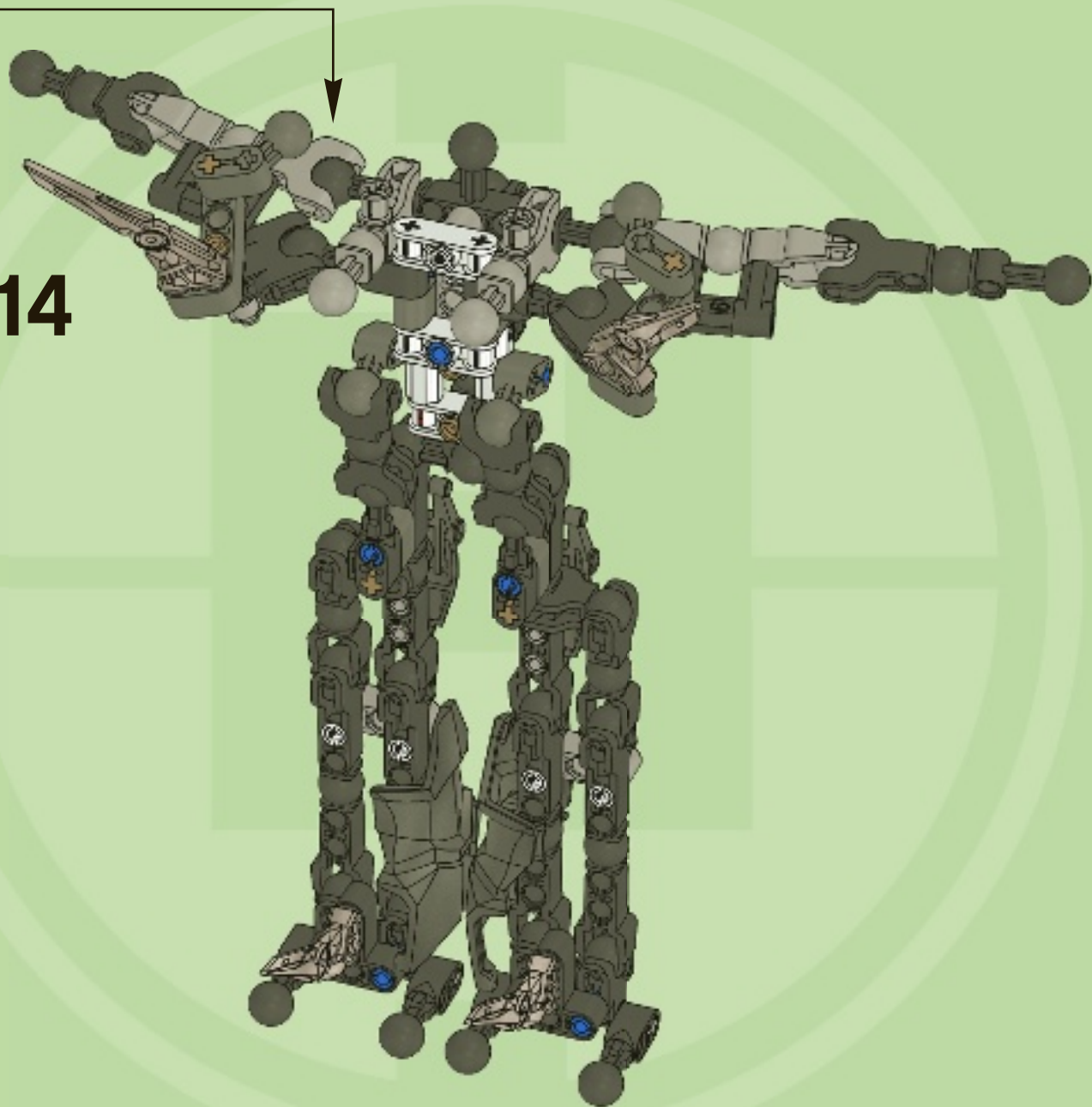

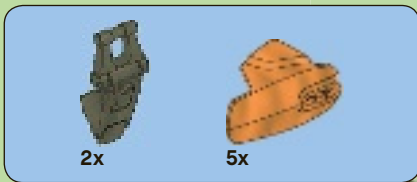

15

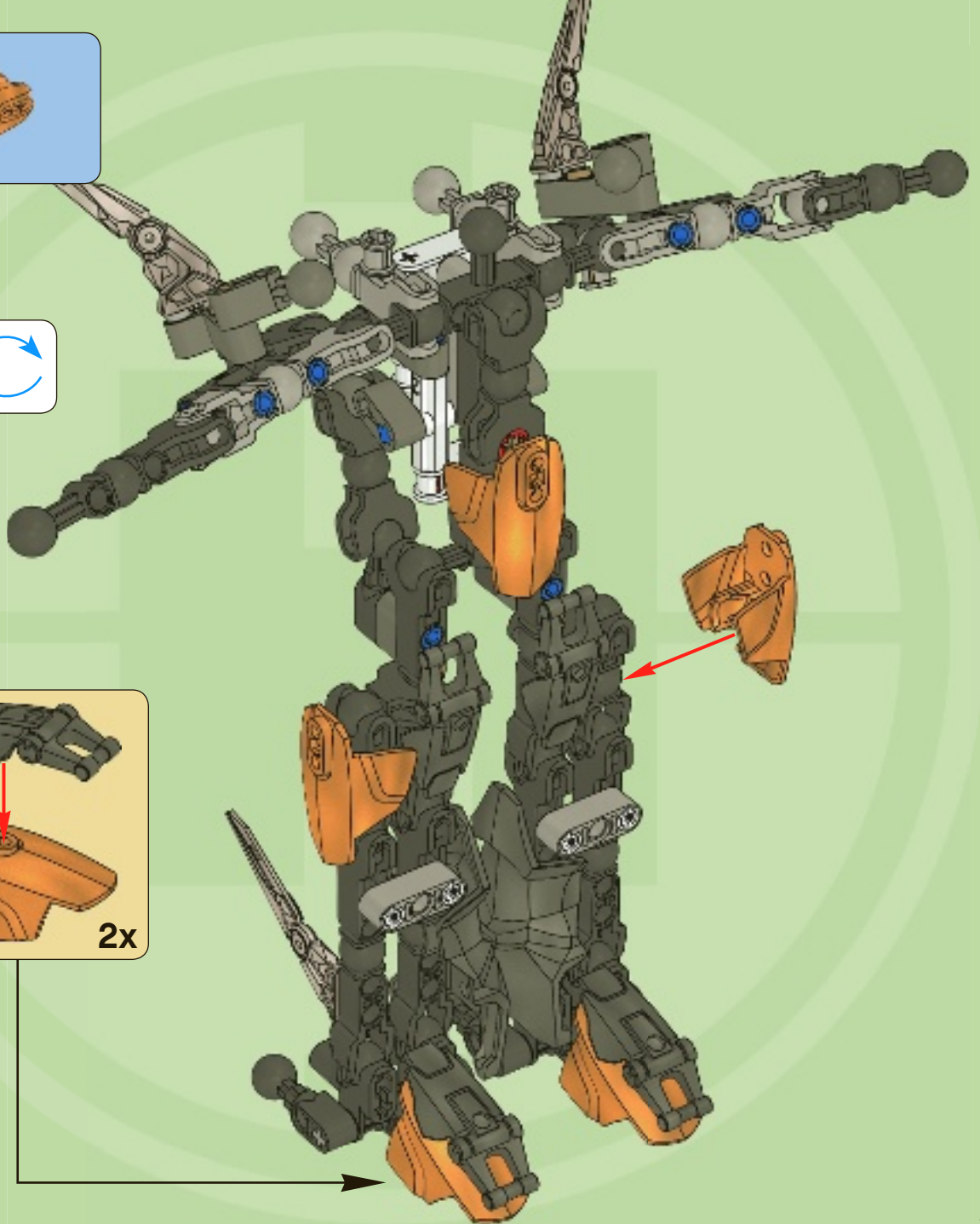
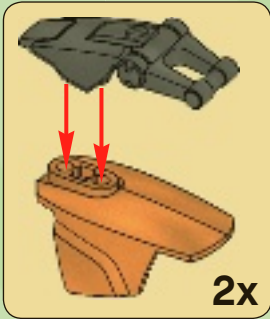



16

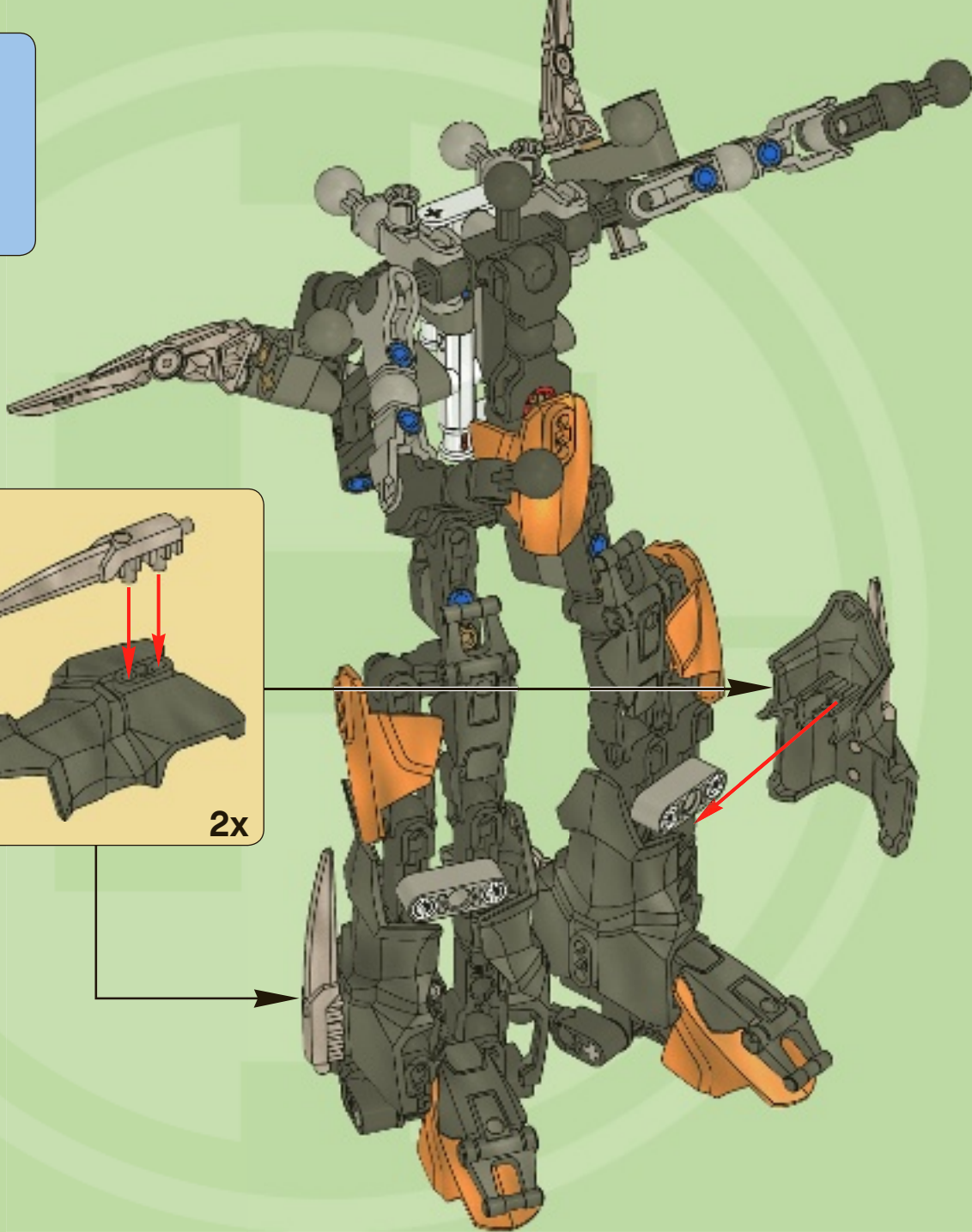
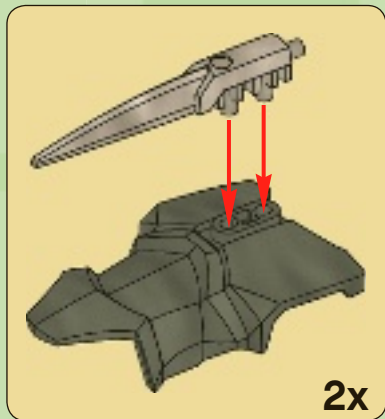





2x

17

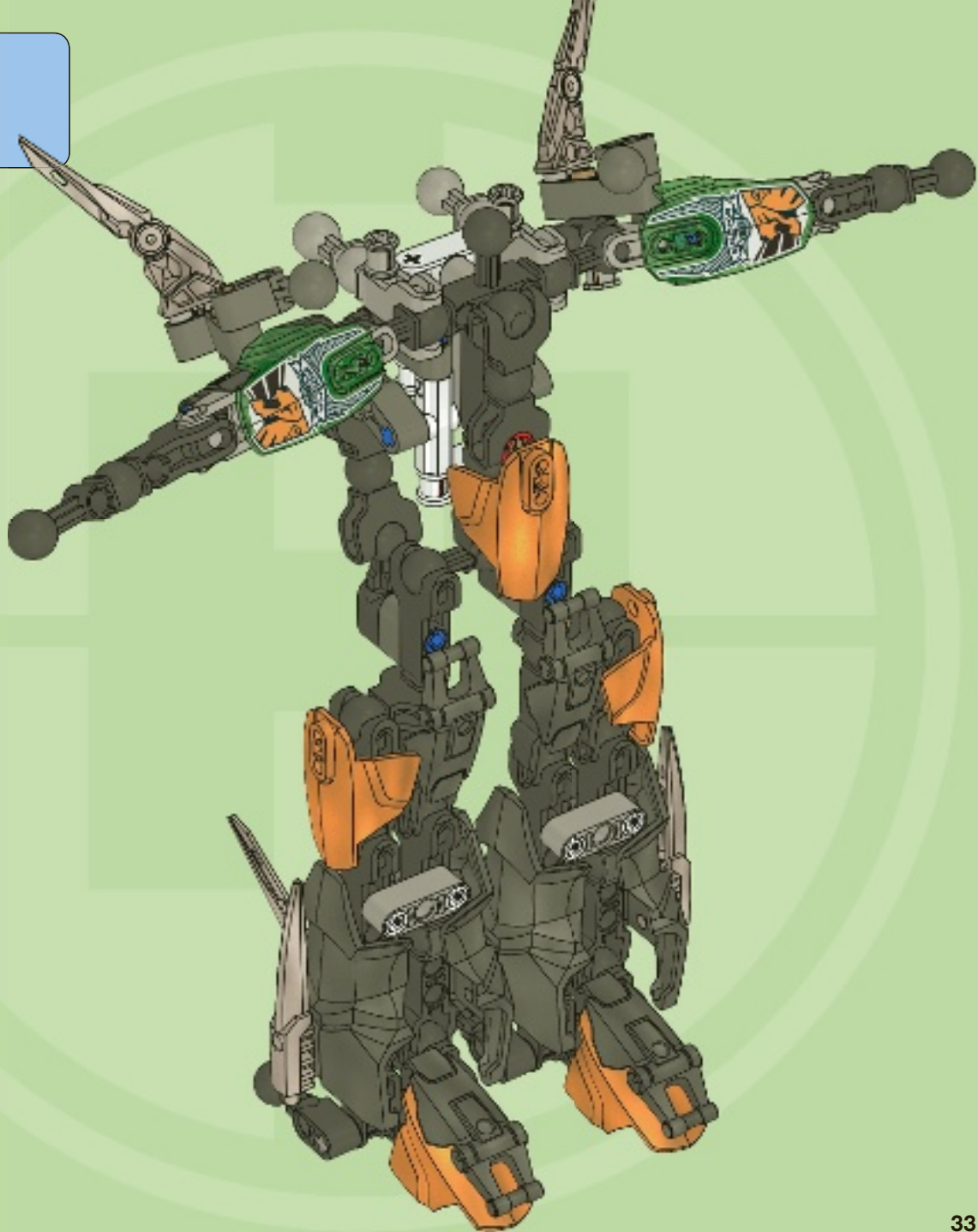

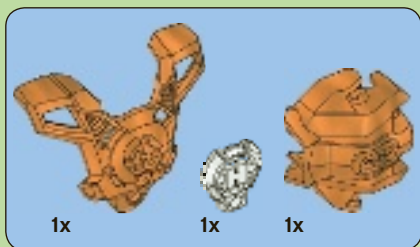

# 18

1

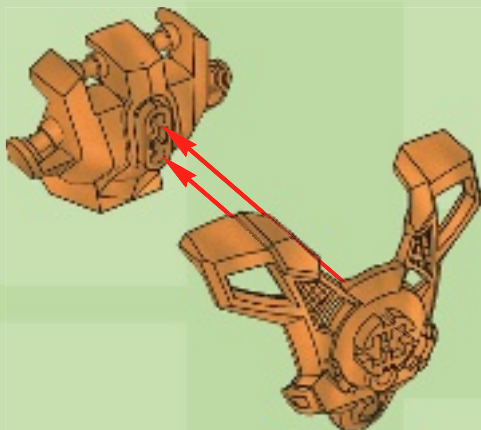

2

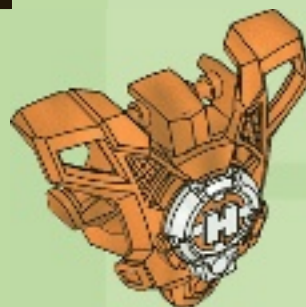

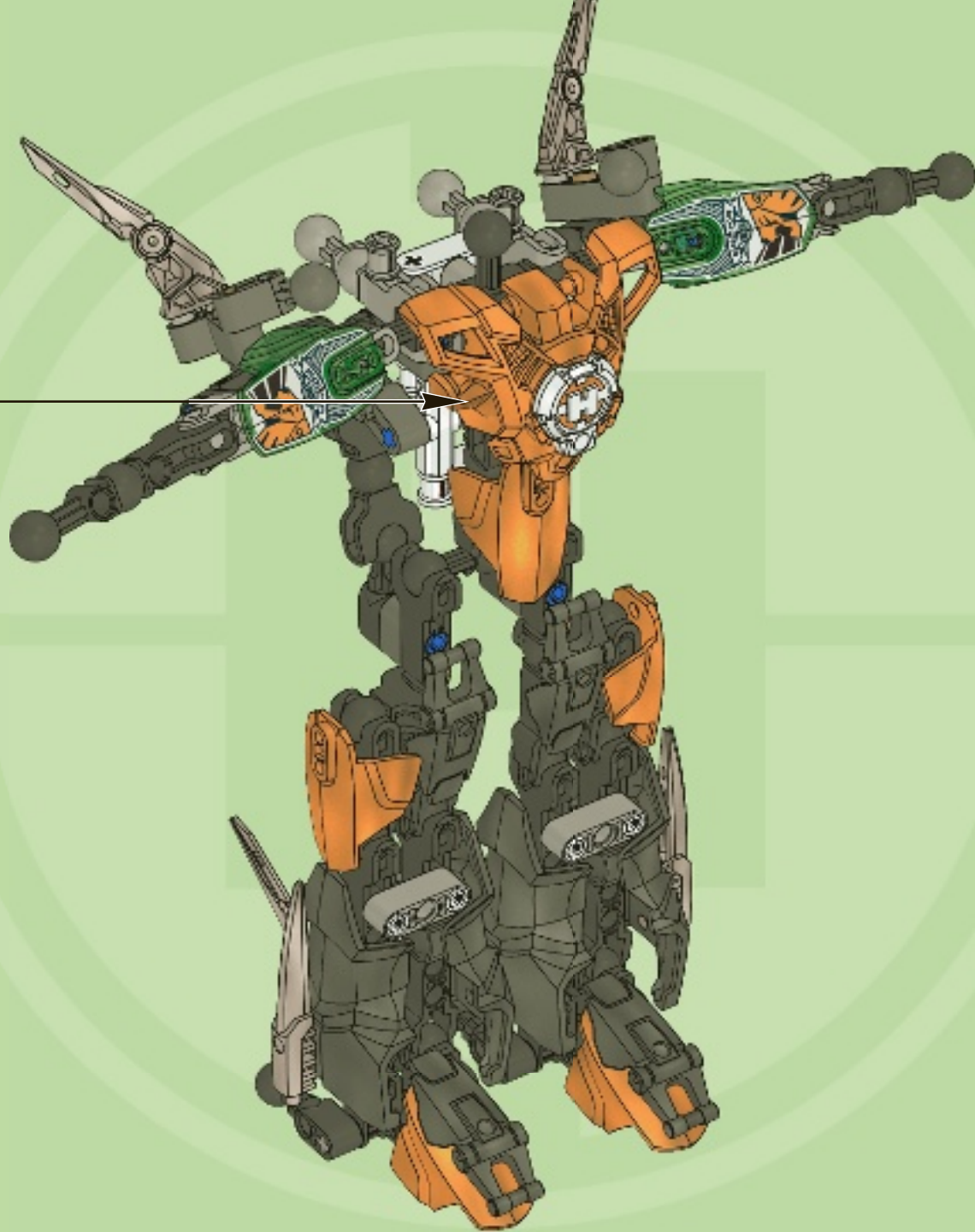

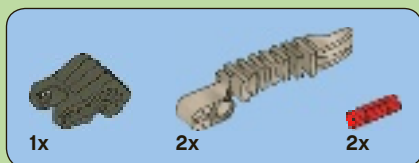

# 19

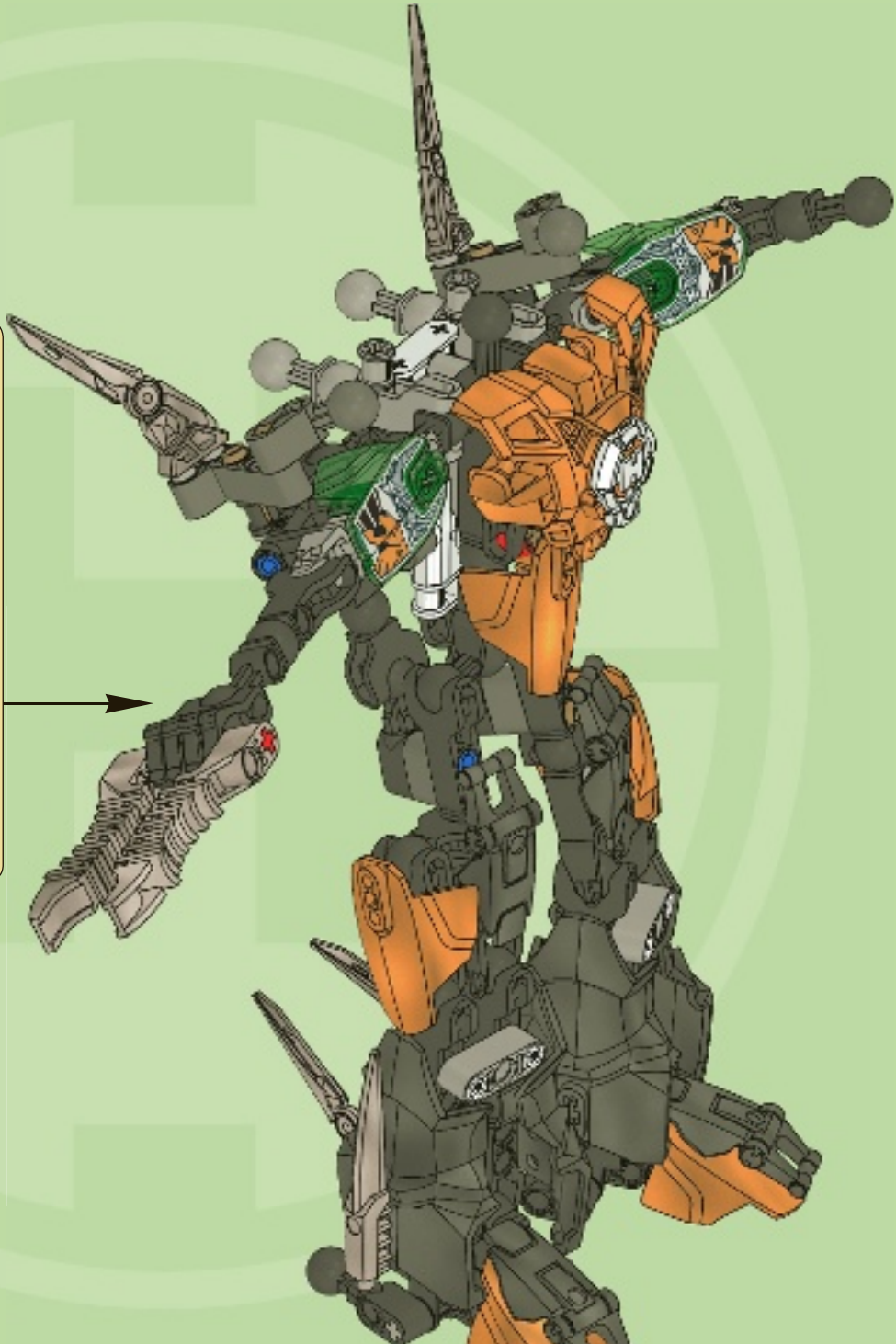
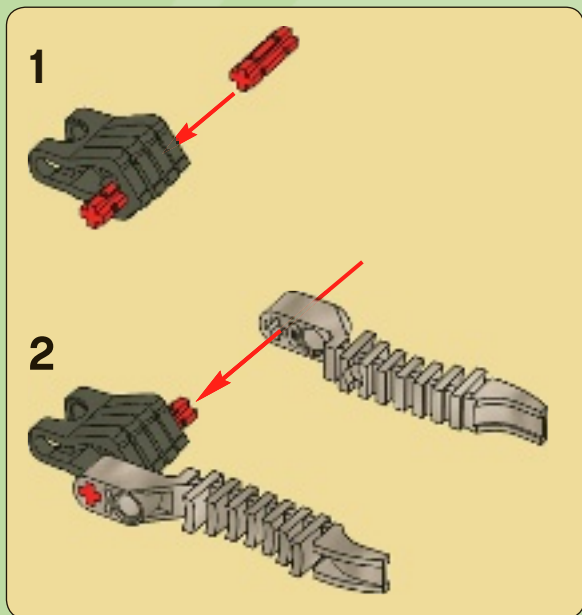



20

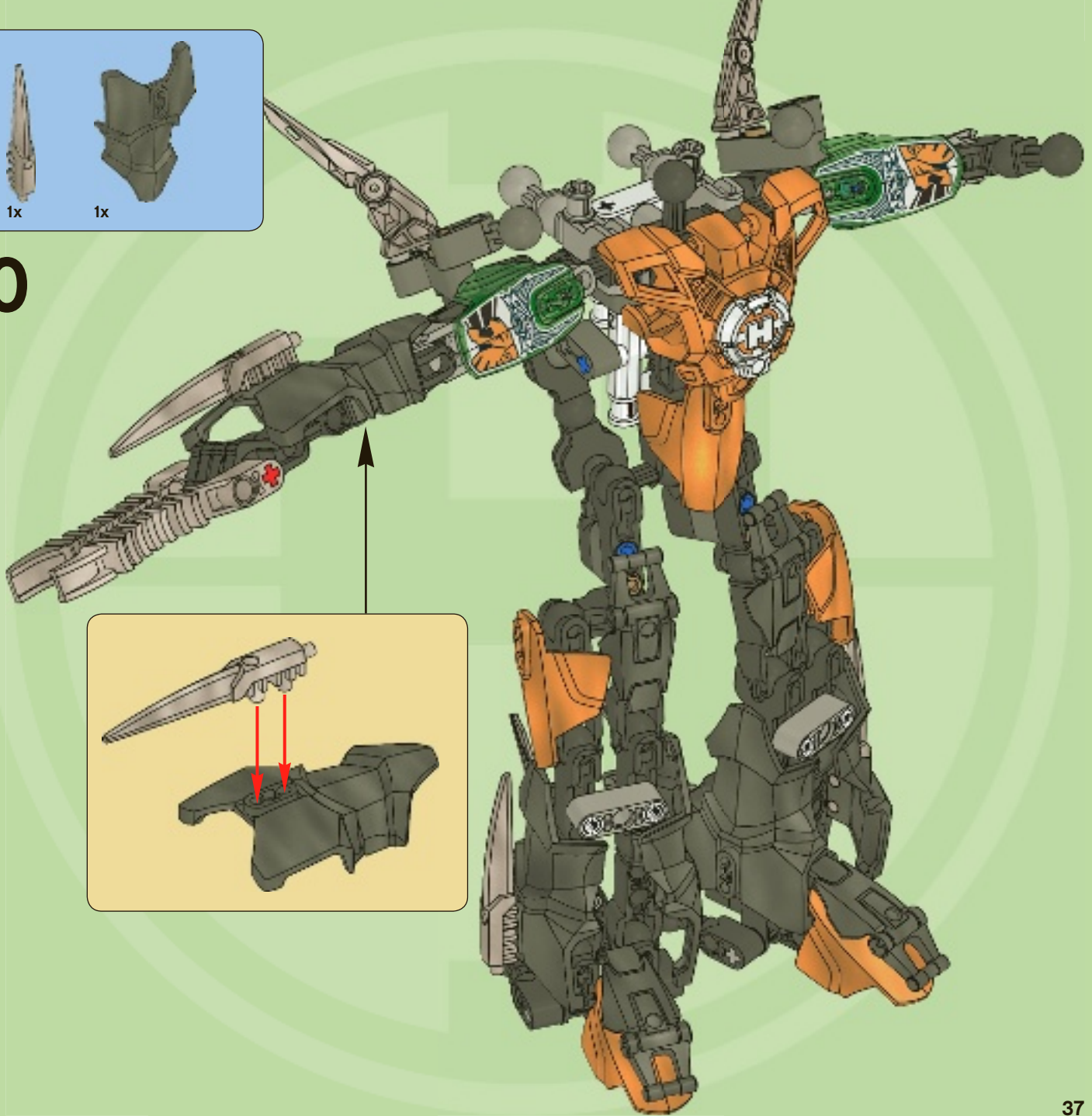

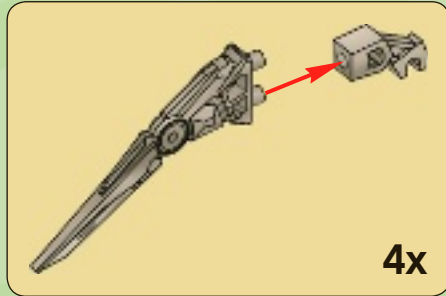
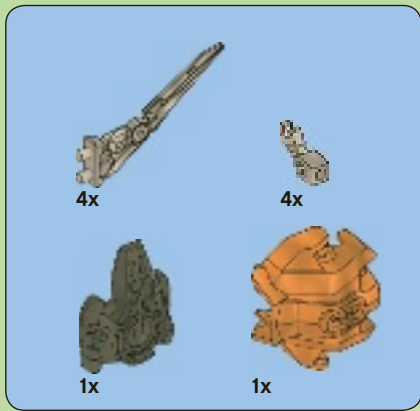

21

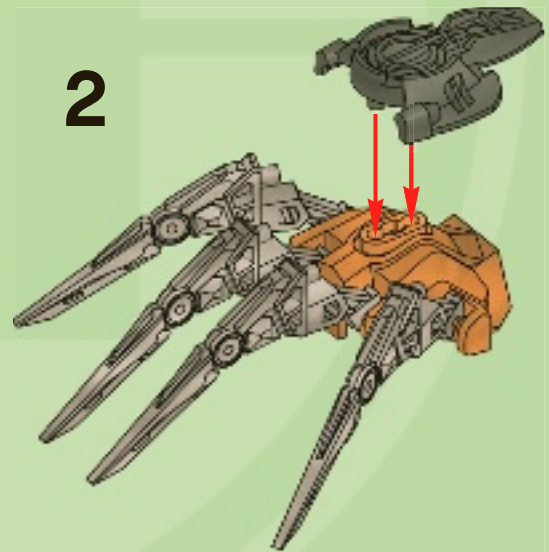
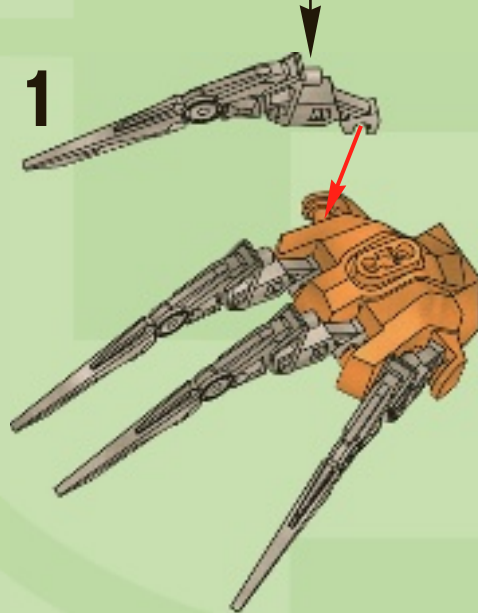

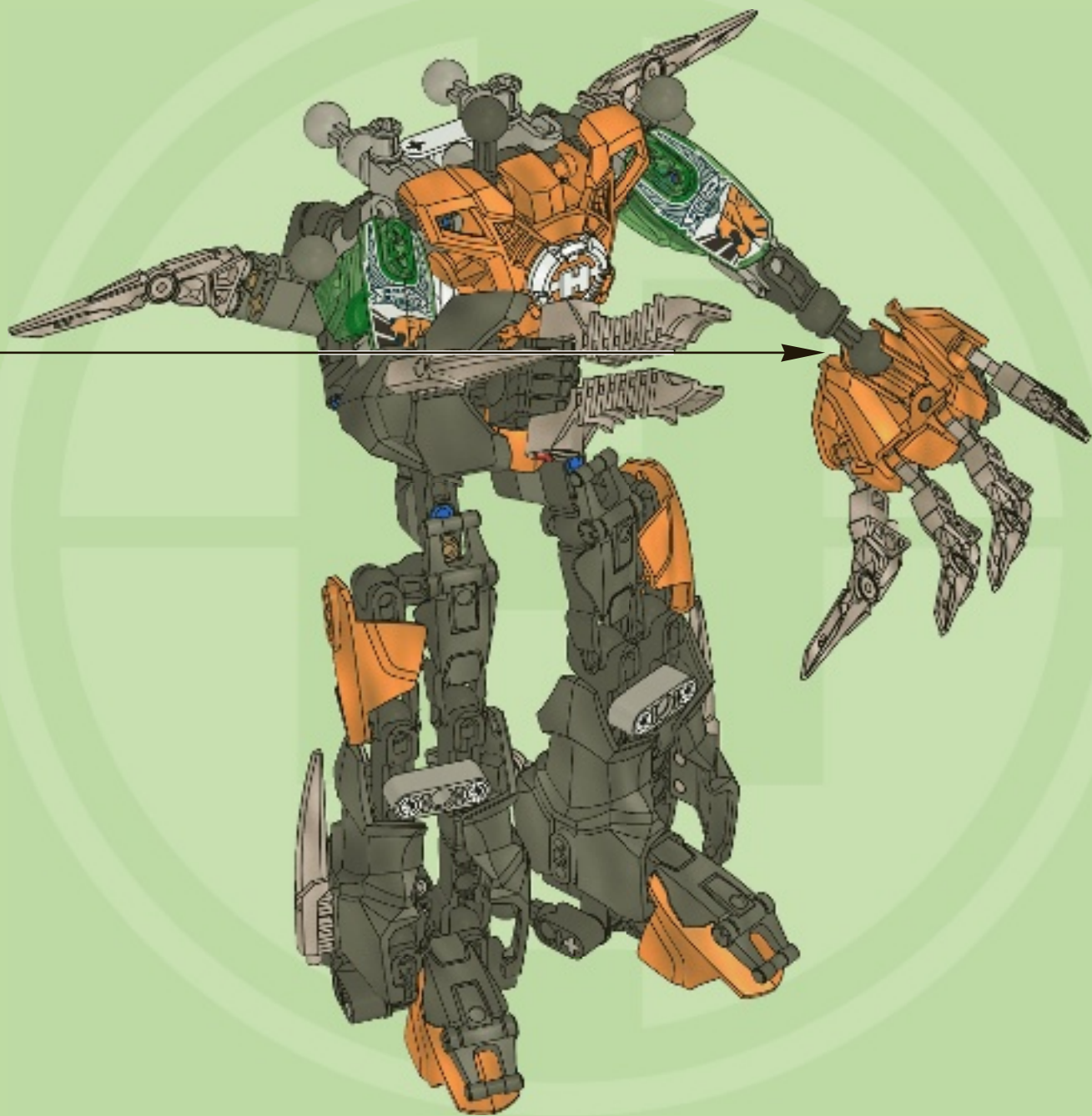

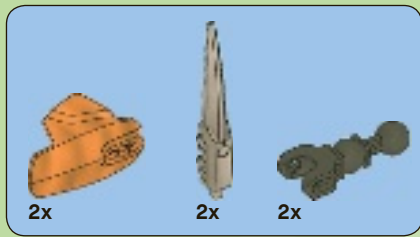

**22**

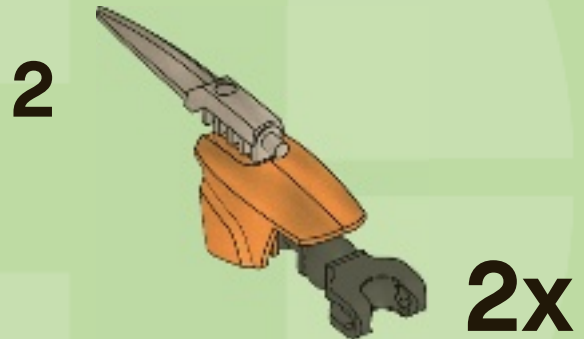
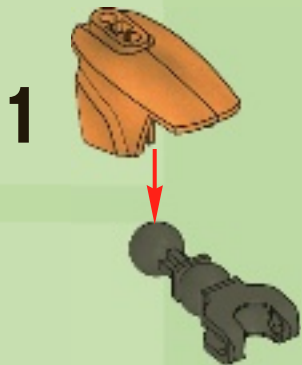



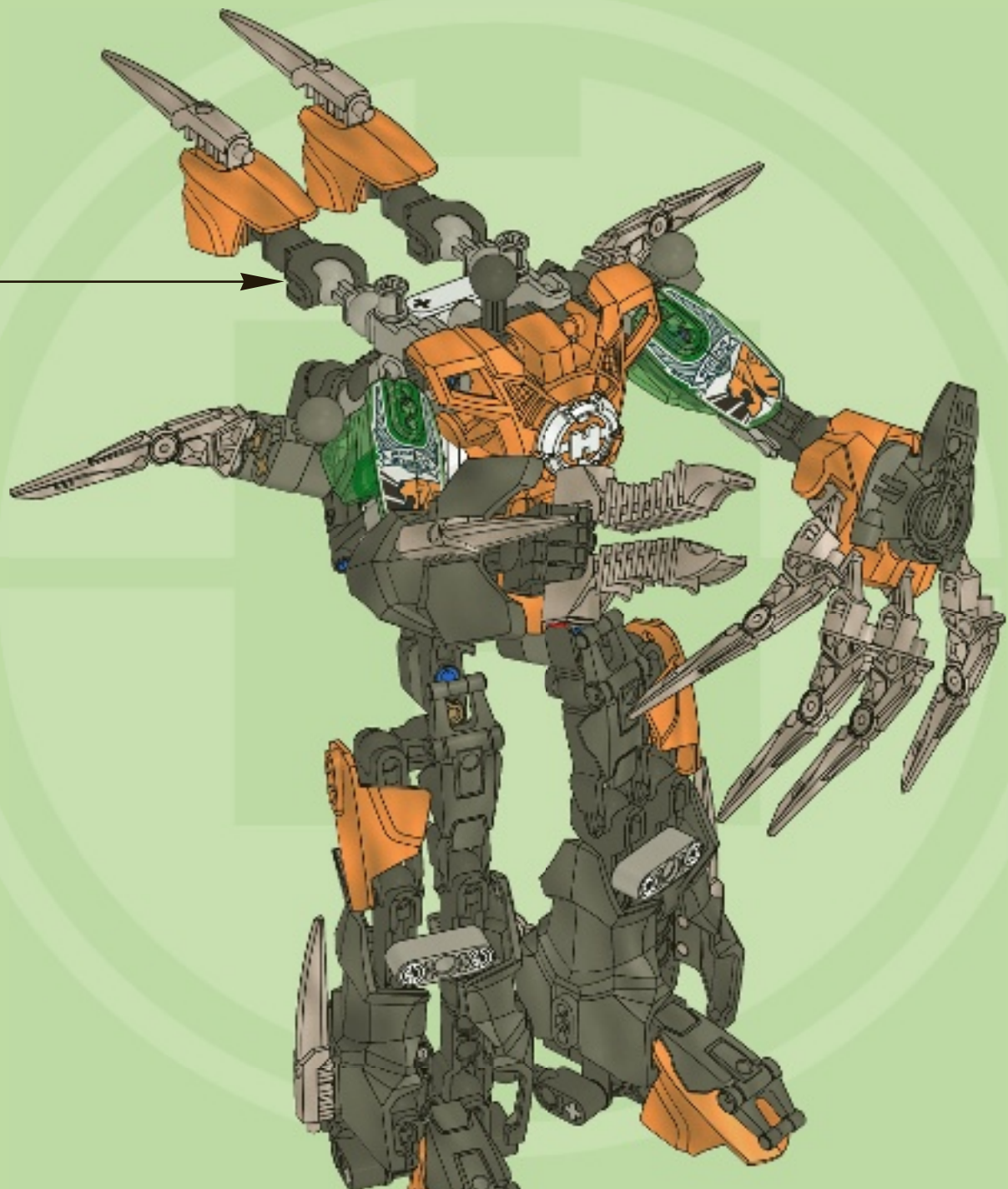

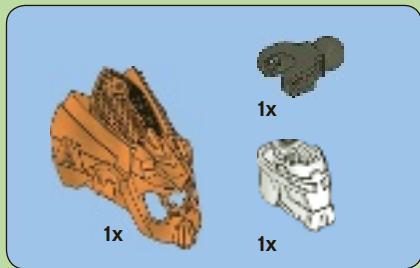

# 23

1

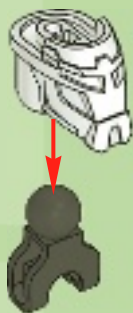

2



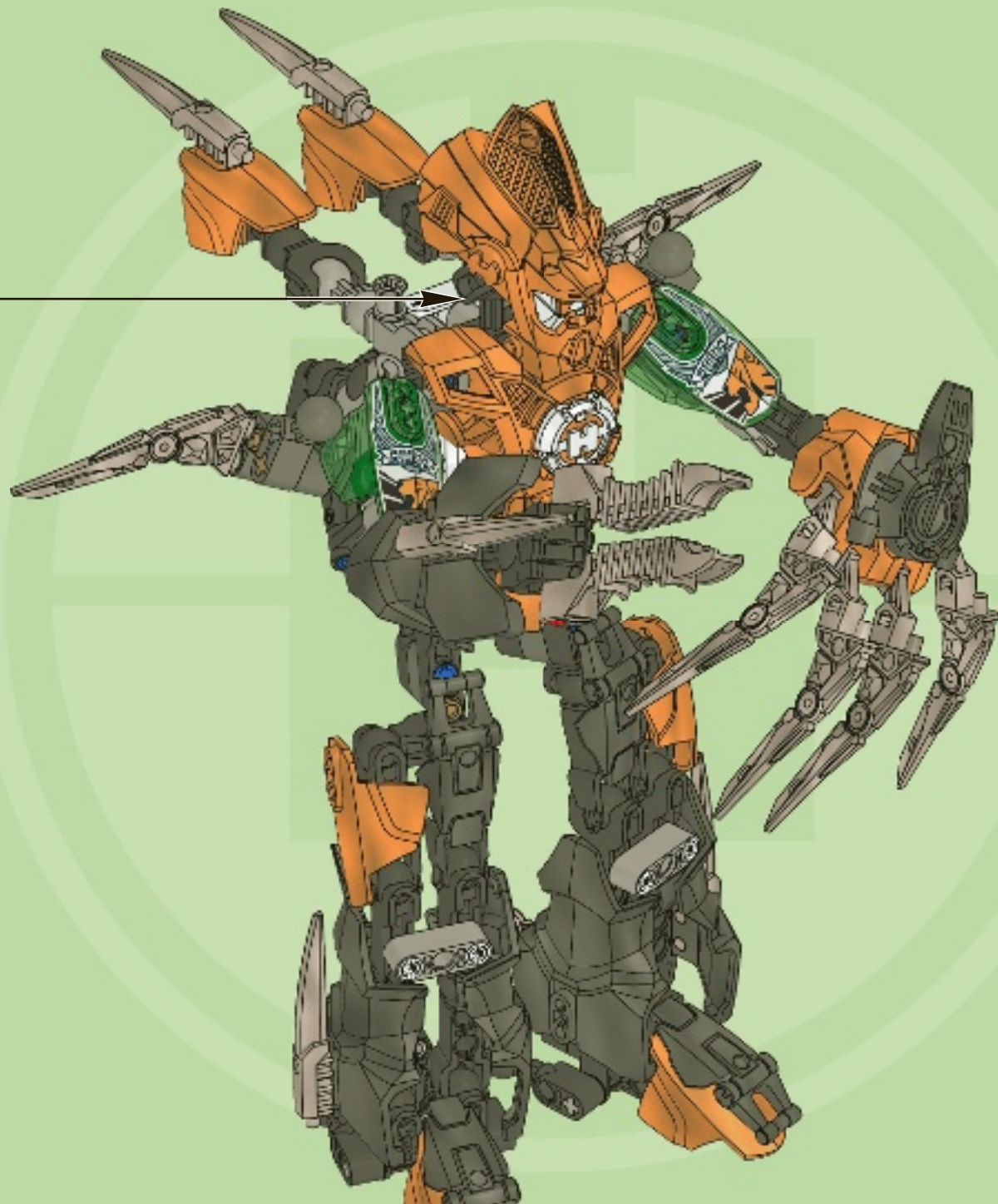

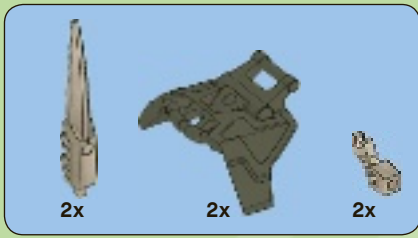

24

1



2

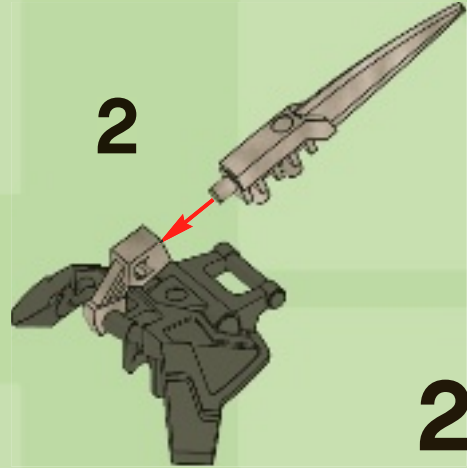

2x

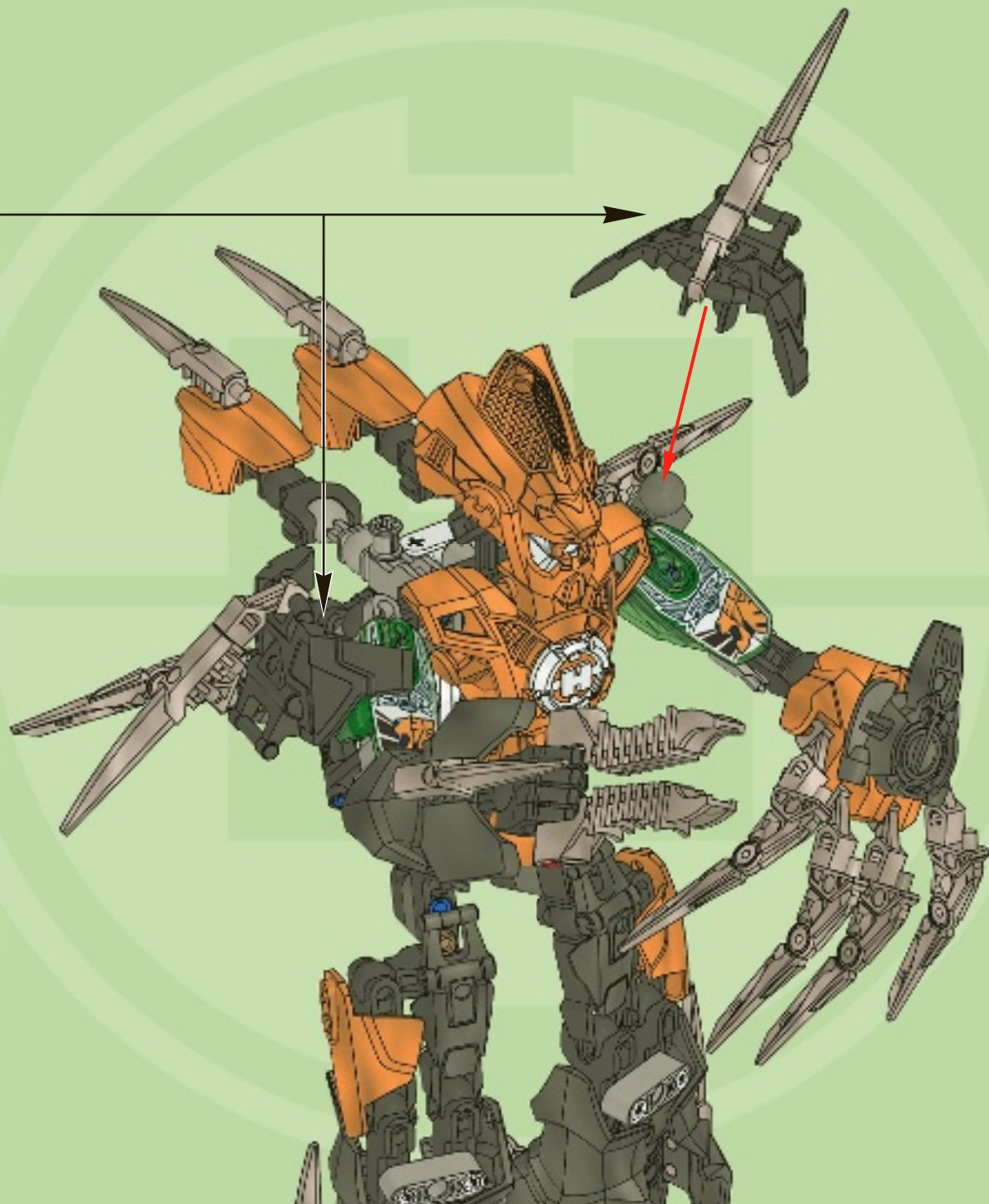



1x

25

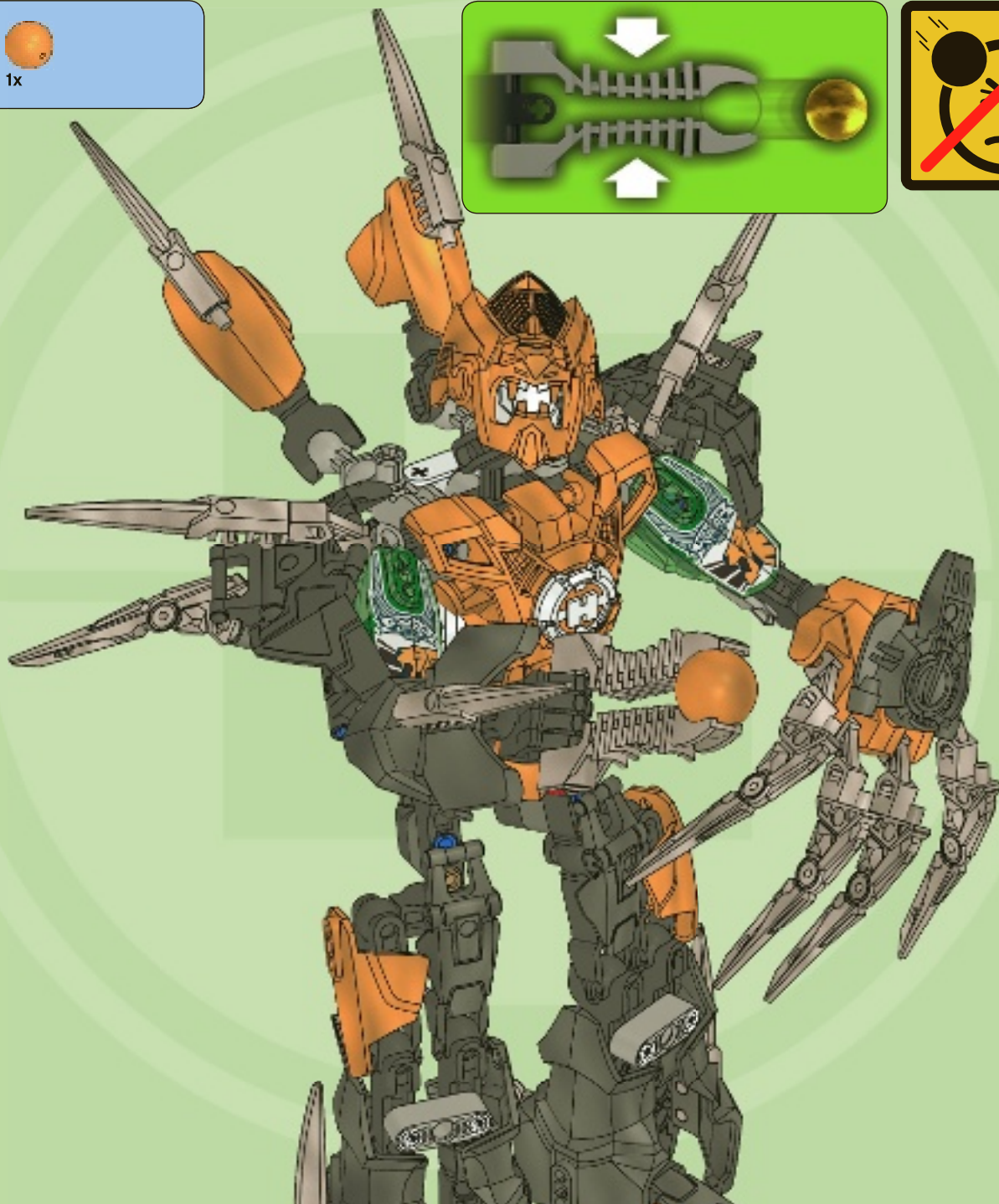
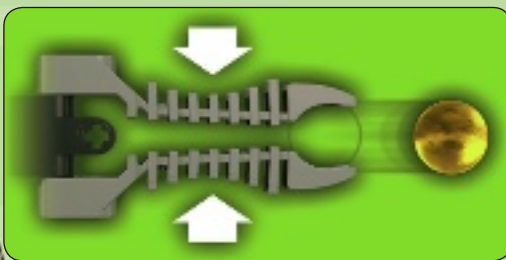



3x  
4144133



1x  
4625868



1x  
4625869



2x  
4125554



2x  
4615070



4x  
4142865



15x  
4206482



3x  
4514553



2x  
4552347



1x  
4290713



6x  
4610948



1x  
4612482



10x  
4560108



3x  
4593557



2x  
4589952



3x  
4593555



3x  
4593567



1x  
4593553



1x  
4593569



6x  
4593558



2x  
4622907



2x  
4107085



6x  
4121715



2x  
4107767



2x  
370526



2x  
4632655



8x  
4566927



2x  
4211655



1x  
4211651



2x  
4609818



2x  
4630073



12x  
4211483



2x  
4211622



2x  
4211865

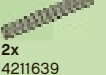

2x  
4211639



4x  
4515183

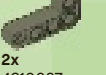

2x  
4210667



4x  
4289258



1x  
4604237



7x  
4632639



2x  
4622882



1x  
4591623



1x  
4594818



6x  
4625564



7x  
4622887



8x  
4591637



2x  
4609595



4x  
4623002



1x  
4609763



5x  
4632593

Customer Service

Kundenservice

Service Consommateurs

Servicio Al Consumidor

[www.lego.com/service](http://www.lego.com/service) or dial



: 00800 5346 5555

: 1-800-422-5346



2236





2145



Now on DVD  
Jetzt auf DVD  
Maintenant en DVD  
Ahora en DVD  
Agora em DVD  
Már kapható DVD-n



HEROFACTORY.LEGO.COM

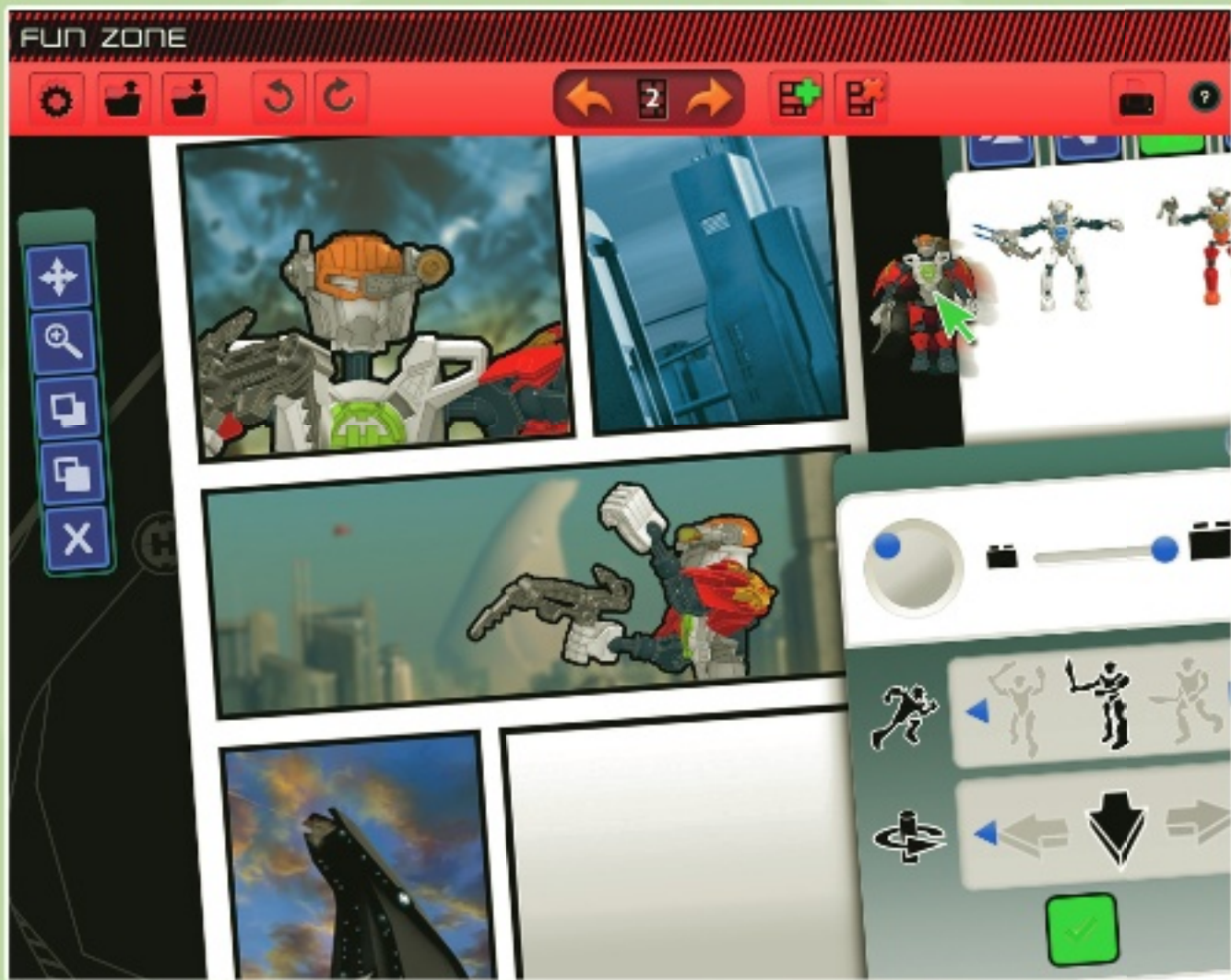

HEROFACTORY.LEGO.COM



HEROFACTORY





HERO  
RECON  
TEAM



[herorecon.LEGO.com](http://herorecon.LEGO.com)



DESIGN by ME



[www.LEGOclub.com](http://www.LEGOclub.com)



LEGO® Club Email

**LEGO club**™

**FREE! GRATIS! GRATUIT!**



LEGO® Club Magazine

**SIGN UP ONLINE!**

**[www.LEGOclub.com](http://www.LEGOclub.com)**



**00800 5346 5555\***



**1-866-534-6258 • 1-877-518-5346**

US & Canada only

Canada seulement

\* Freephone. Mobile charges may apply.  
\* Numéro sans frais. Des frais peuvent s'appliquer avec les téléphones cellulaires.  
\* Gebührenfrei, Kosten für Anrufe aus Mobilfunknetzen können abweichen.  
\* Gratis telefonnummer vanaf vaste lijn.  
\* Det er et gratis nummer, når du ringer fra fasttelefon.  
\* Det är gratis, när du ringer från en fast telefon.  
\* Numéro sans frais. Des frais peuvent s'appliquer avec les téléphones portables.

B1115





# WIN!

Go to [www.LEGOsurvey.com/product](http://www.LEGOsurvey.com/product)  
to fill out a survey for a chance  
to win a cool LEGO® Product.

No purchase necessary.

Open to all residents where not prohibited.



[www.LEGO.com](http://www.LEGO.com)



## [www.LEGOsurvey.com/product](http://www.LEGOsurvey.com/product)

### GEWINNE! WIN!

Nimm an der Umfrage auf  
[www.LEGOsurvey.com/product](http://www.LEGOsurvey.com/product)  
teil und hab die Chance ein cooles  
LEGO® Produkt zu gewinnen!

Die Teilnahme am Gewinnspiel führt zu keinerlei  
Kaufverpflichtungen. Teilnahme in allen nicht  
ausgeschlossenen Ländern möglich.

Ga naar [www.LEGOsurvey.com/product](http://www.LEGOsurvey.com/product),  
vul een enquêteformulier  
in en maak kans op een  
cool LEGO® product.

Geen aankoopverplichting.  
Iedereen mag deelnemen, uitzonderend  
ingezetenden van landen waar een  
enquêteverbod geldt.

### GAGNE! 当てよう!

Visite [www.LEGOsurvey.com/product](http://www.LEGOsurvey.com/product)  
pour répondre à un  
questionnaire et avoir une chance de  
gagner un produit LEGO® très cool!

Aucune obligation d'achat.  
Ouvert à tous les résidents des pays  
autorisés.

[www.LEGOsurvey.com/product](http://www.LEGOsurvey.com/product) にアクセスして、  
アンケートにご記入ください。当選者にはレゴ®  
製品を差し上げます。

お買い上げの必要はありません。

禁止されていない限り、すべての皆様にご利用いただけます。