



TECHNIC

42030



VOLVO



This device complies with part 15 of the FCC Rules. Operation is subject to the following two conditions: (1) This device may not cause harmful interference, and (2) this device must accept any interference received, including interference that may cause undesired operation.

NOTE: This equipment has been tested and found to comply with the limits for a Class B digital device, pursuant to part 15 of the FCC Rules. These limits are designed to provide reasonable protection against harmful interference in a residential installation. This equipment generates, uses and can radiate radio frequency energy and, if not installed and used in accordance with the instructions, may cause harmful interference to radio communications. However, there is no guarantee that interference will not occur in a particular installation. If this equipment does cause harmful interference to radio or television reception, which can be determined by turning the equipment off and on, the user is encouraged to try to correct the interference by one or more of the following measures:

- Reorient or relocate the receiving antenna.
- Increase the separation between the equipment and receiver.
- Connect the equipment into an outlet on a circuit different from that to which the receiver is connected.
- Consult the dealer or an experienced radio/TV technician for help.

Caution: Changes or modifications not expressly approved by the party responsible for compliance could void the user's authority to operate the equipment.

This Class B digital apparatus complies with Canadian ICES-003.
Cet appareil numérique de la classe B est conforme à la norme NMB-003 du Canada.

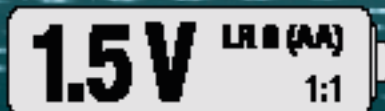

6x



6x

EN

Important information about batteries:
Always use identical types of batteries together, or a combination of old and new batteries. Always remove the batteries if they are not to be used for a long time or if the batteries have run down. Never use damaged batteries. Only use batteries of the type recommended, or a corresponding type. Insert the batteries so that the poles are correctly positioned. Rechargeable batteries must be recharged using the correct charging device. Always charge batteries fully. Put unused recharge batteries into the correct bin. Do not use the product, and do not touch it, if it is broken. Never charge or use damaged or recharged batteries. Never short-circuit the battery poles.

DE

Wichtige Informationen zu Batterien:
Nur zusammenfassend zusammenfügen. Arten von Batterien oder alte und neue Zellen. Niemals die Pole der Zellen falsch verbinden, sonst wird das Produkt beschädigt. Die Zellen sind korrekt einstecken. Die Zellen müssen vollständig geladen sein. Gebrauchte Batterien müssen in die dafür vorgesehenen Behälter für wiederverwendbare Batterien oder in die dafür vorgesehenen Behälter für nicht wiederverwendbare Batterien gegeben werden. Die Zellen müssen vollständig geladen sein. Gebrauchte Batterien müssen in die dafür vorgesehenen Behälter für wiederverwendbare Batterien oder in die dafür vorgesehenen Behälter für nicht wiederverwendbare Batterien gegeben werden. Die Zellen müssen vollständig geladen sein. Gebrauchte Batterien müssen in die dafür vorgesehenen Behälter für wiederverwendbare Batterien oder in die dafür vorgesehenen Behälter für nicht wiederverwendbare Batterien gegeben werden.

FR

Informations importantes concernant les piles:
Ne jamais mélanger un mélange de différents types de piles, ou de piles neuves et de piles déchargées ou piles usées. Ne jamais relier les pôles de la pile. Ne jamais utiliser des piles de différentes marques. Ne jamais utiliser des piles usées. Ne jamais utiliser de piles rechargeables. Lire attentivement les instructions. Ne jamais utiliser des piles rechargeables si elles ne sont pas complètement chargées. Ne jamais utiliser des piles rechargeables si elles ne sont pas complètement chargées. Ne jamais utiliser des piles rechargeables si elles ne sont pas complètement chargées.

IT

Informazioni importanti sulle batterie:
Non mescolare mai batterie cariche e batterie scariche o batterie usate insieme. Non mescolare mai batterie di diverse marche. Non mescolare mai batterie di diverse marche. Non mescolare mai batterie di diverse marche. Non mescolare mai batterie di diverse marche. Non mescolare mai batterie di diverse marche.

PL

Ważne informacje dotyczące baterii:
Nigdy nie łączyć baterii o różnych rodzajach. Nigdy nie łączyć baterii o różnych rodzajach. Nigdy nie łączyć baterii o różnych rodzajach. Nigdy nie łączyć baterii o różnych rodzajach. Nigdy nie łączyć baterii o różnych rodzajach.

ES

Importante información acerca de las pilas:
No mezclar tipos de pilas diferentes. No mezclar pilas nuevas y pilas usadas. No mezclar pilas de diferentes marcas. No mezclar pilas de diferentes marcas. No mezclar pilas de diferentes marcas.

DA

Vigtige oplysninger om batterier:
Ikke bland forskellige batterier sammen. Ikke bland forskellige batterier sammen. Ikke bland forskellige batterier sammen. Ikke bland forskellige batterier sammen. Ikke bland forskellige batterier sammen.

PT

Atenção: duas paragens:
Não misture pilas diferentes. Não misture pilas diferentes. Não misture pilas diferentes. Não misture pilas diferentes. Não misture pilas diferentes.

SV

Viktig information om batterier:
Bland aldrig olika typer av batterier. Bland aldrig olika typer av batterier. Bland aldrig olika typer av batterier. Bland aldrig olika typer av batterier. Bland aldrig olika typer av batterier.

FY

Informacje importanti sobre as pilhas:
Nunca misture tipos de pilhas diferentes. Nunca misture tipos de pilhas diferentes. Nunca misture tipos de pilhas diferentes. Nunca misture tipos de pilhas diferentes. Nunca misture tipos de pilhas diferentes.

EL

Σημαντικές πληροφορίες για τις μπαταρίες:
Ποτέ μην αναμειγνύετε μπαταρίες διαφορετικών τύπων. Ποτέ μην αναμειγνύετε μπαταρίες διαφορετικών τύπων. Ποτέ μην αναμειγνύετε μπαταρίες διαφορετικών τύπων.



ZH

关于电池的警告:
切勿将不同类型的电池混合使用。切勿将不同类型的电池混合使用。切勿将不同类型的电池混合使用。

RU

Важная информация об аккумуляторах:
Никогда не смешивайте аккумуляторы разных типов. Никогда не смешивайте аккумуляторы разных типов. Никогда не смешивайте аккумуляторы разных типов.

HU

Fontos információk az akkumulátorokról:
Soha ne keverjenek különböző típusú akkumulátorokat. Soha ne keverjenek különböző típusú akkumulátorokat. Soha ne keverjenek különböző típusú akkumulátorokat.

PL

Ważne informacje dotyczące baterii:
Nigdy nie łączyć baterii o różnych rodzajach. Nigdy nie łączyć baterii o różnych rodzajach. Nigdy nie łączyć baterii o różnych rodzajach.

CZ

Důležité informace o bateriích:
Nikdy neovládajte rozličných typů baterií. Nikdy neovládajte rozličných typů baterií. Nikdy neovládajte rozličných typů baterií.

SK

Informácie dôležité o batériách:
Nikdy neovládajte rozličných typů baterií. Nikdy neovládajte rozličných typů baterií. Nikdy neovládajte rozličných typů baterií.

HU

Fontos információk az akkumulátorokról:
Soha ne keverjenek különböző típusú akkumulátorokat. Soha ne keverjenek különböző típusú akkumulátorokat. Soha ne keverjenek különböző típusú akkumulátorokat.

UA

Важні відомості про акумулятори:
Ніколи не сумішуйте акумулятори різних типів. Ніколи не сумішуйте акумулятори різних типів. Ніколи не сумішуйте акумулятори різних типів.

FR
 Mettes abandonné à terre
 Ne jetez jamais l'emballage usagé vers l'extérieur, mais laissez-le accumuler dans la poubelle locale. Une fois rempli, l'emballage usagé peut être réutilisé ou recyclé. Ne laissez jamais l'emballage usagé accumuler dans le jardin, la cour ou dans toute autre zone. L'emballage usagé peut être réutilisé ou recyclé. Ne jetez jamais l'emballage usagé vers l'extérieur, mais laissez-le accumuler dans la poubelle locale. Une fois rempli, l'emballage usagé peut être réutilisé ou recyclé. Ne laissez jamais l'emballage usagé accumuler dans le jardin, la cour ou dans toute autre zone.

IT
 Pannelli abbandonati a terra
 Non gettare mai l'imballaggio usato verso l'esterno, ma lasciarlo accumulare nella poubella locale. Una volta pieno, l'imballaggio usato può essere riutilizzato o riciclato. Non lasciare mai l'imballaggio usato accumulare nel giardino, nel cortile o in qualsiasi altra area. L'imballaggio usato può essere riutilizzato o riciclato. Non gettare mai l'imballaggio usato verso l'esterno, ma lasciarlo accumulare nella poubella locale. Una volta pieno, l'imballaggio usato può essere riutilizzato o riciclato. Non lasciare mai l'imballaggio usato accumulare nel giardino, nel cortile o in qualsiasi altra area.

DE
 Verpackungen abgeworfen an der Erde
 Nie das Verpackungsmaterial des Gerätes nach außen wegschmeißen, sondern sammeln Sie es in der örtlichen Mülltonne. Sobald diese voll ist, kann das Verpackungsmaterial des Gerätes wiederverwendet oder recycelt werden. Lassen Sie das Verpackungsmaterial des Gerätes niemals im Garten, auf dem Hof oder in irgendeiner anderen Zone liegen. Das Verpackungsmaterial des Gerätes kann wiederverwendet oder recycelt werden. Lassen Sie das Verpackungsmaterial des Gerätes niemals im Garten, auf dem Hof oder in irgendeiner anderen Zone liegen.

ET
 Pakettid jäävildat maale
 Ära kunagi heita ära kasutatud pakendi materjali välja. Kogu kasutatud pakendi materjal koguda kohalikus prügis. Kui prügis on täis, võib kasutatud pakendi materjali ümberkasutada või taaskasutada. Ärge kunagi heita kasutatud pakendi materjali aias, aias või muul muul alal. Kasutatud pakendi materjal võib ümberkasutada või taaskasutada. Ärge kunagi heita kasutatud pakendi materjali aias, aias või muul muul alal.

TH
 ปล่อยหีบห่อทิ้งไว้ที่พื้น
 ห้ามทิ้งวัสดุหีบห่อที่ใช้แล้วทิ้งไว้ข้างนอก แต่ให้เก็บไว้ในถังขยะท้องถิ่นที่เต็มไปด้วยแล้วเท่านั้น เมื่อถังขยะท้องถิ่นเต็มแล้ว วัสดุหีบห่อที่ใช้แล้วทิ้งอาจนำกลับมาใช้ใหม่หรือรีไซเคิลได้ ห้ามทิ้งวัสดุหีบห่อที่ใช้แล้วทิ้งไว้ในสวน บริเวณสนามหญ้า หรือที่ใดก็ตาม

EN
 Boxes left unattended on the ground
 Never throw used packaging materials outside, but collect them in your local authority recycling centre and facilities. Once full, used packaging materials can be reused or recycled. Never let used packaging materials accumulate in the garden, yard or any other zone. Used packaging materials can be reused or recycled. Never let used packaging materials accumulate in the garden, yard or any other zone.

ES
 Embalajes abandonados a tierra
 Nunca deseches el embalaje usado fuera de casa, sino que debes reunirlos en el contenedor de reciclaje de tu localidad. Cuando el contenedor de reciclaje está lleno, el embalaje usado puede reutilizarse o reciclarse. Nunca dejes que el embalaje usado acumule en el jardín, patio o cualquier otra zona. El embalaje usado puede reutilizarse o reciclarse. Nunca dejes que el embalaje usado acumule en el jardín, patio o cualquier otra zona.

FR
 Boîtes laissées à terre
 Ne jetez jamais les emballages usés vers l'extérieur, mais collectez-les dans la poubelle locale. Une fois pleine, les emballages usés peuvent être réutilisés ou recyclés. Ne laissez jamais les emballages usés s'accumuler dans le jardin, la cour ou toute autre zone. Les emballages usés peuvent être réutilisés ou recyclés. Ne laissez jamais les emballages usés s'accumuler dans le jardin, la cour ou toute autre zone.

IT
 Scatole abbandonate a terra
 Non buttare mai l'imballaggio usato all'esterno, ma raccogliete i rifiuti nella poubella locale. Una volta piena, l'imballaggio usato può essere riutilizzato o riciclato. Non lasciate mai l'imballaggio usato accumulare in giardino, in cortile o in qualsiasi altra area. L'imballaggio usato può essere riutilizzato o riciclato. Non lasciate mai l'imballaggio usato accumulare in giardino, in cortile o in qualsiasi altra area.

DE
 Kartons auf dem Boden liegen lassen
 Werfen Sie niemals das Verpackungsmaterial des Geräts nach außen, sondern sammeln Sie es in der örtlichen Mülltonne. Sobald diese voll ist, kann das Verpackungsmaterial des Gerätes wiederverwendet oder recycelt werden. Lassen Sie das Verpackungsmaterial des Gerätes niemals im Garten, auf dem Hof oder in irgendeiner anderen Zone liegen. Das Verpackungsmaterial des Gerätes kann wiederverwendet oder recycelt werden. Lassen Sie das Verpackungsmaterial des Gerätes niemals im Garten, auf dem Hof oder in irgendeiner anderen Zone liegen.



- EN Please do not discard by not disposing of this product with your household waste (EUROPEAN). Check with your local authority for recycling advice and facilities.
- DE Behalten Sie die Umhüllend und abzugeben die lokale Behälter nicht mit Ihrem Haushalt (EUROPEAN). Informationen zu Recycling-Möglichkeiten erhalten Sie bei den örtlichen Behörden.
- FR Protégez l'environnement: ne jetez pas ce produit avec vos autres déchets ménagers (EUROPEAN). Consultez les autorités locales pour obtenir des informations sur le recyclage et connaître les points de collecte.
- IT Proteggi l'ambiente! Non smaltire questo prodotto con i rifiuti domestici (EUROPEAN). Per informazioni sul riciclaggio dell'attrezzo e la struttura di riciclaggio, rivolgerti alle proprie autorità locali.
- EL Διατηρήστε τον περιβάλλοντα καθαρό με τη σωστή απόθεση των προϊόντων (EUROPEAN). Συζητήστε με τις τοπικές αρχές για πληροφορίες σχετικά με τον καθαρισμό και την απόθεση.
- ES Mantén el medio ambiente limpio al disponer este producto con los residuos domésticos (EUROPEAN). Consulta de información acerca instalaciones de reciclaje.
- ET Hoidke keskkonda puhtaks: ära visake see toode koos teie koduse jäämääga (EUROPEAN). Kontrollige kohalike võimadega selle toote käsitsemise ja kõrvaldamise kohta.
- TH รักษาสิ่งแวดล้อมอย่าทิ้งของกับขยะบ้าน (EUROPEAN). ติดต่อหน่วยงานท้องถิ่นเพื่อขอคำแนะนำและข้อมูลเกี่ยวกับการกำจัดของใช้.
- FR Protégez l'environnement: ne jetez pas ce produit avec vos autres déchets ménagers (EUROPEAN). Consultez les autorités locales pour obtenir des informations sur le recyclage et connaître les points de collecte.
- DE Behalten Sie die Umhüllend und abzugeben die lokale Behälter nicht mit Ihrem Haushalt (EUROPEAN). Informationen zu Recycling-Möglichkeiten erhalten Sie bei den örtlichen Behörden.
- FR Protégez l'environnement: ne jetez pas ce produit avec vos autres déchets ménagers (EUROPEAN). Consultez les autorités locales pour obtenir des informations sur le recyclage et connaître les points de collecte.
- IT Proteggi l'ambiente! Non smaltire questo prodotto con i rifiuti domestici (EUROPEAN). Per informazioni sul riciclaggio dell'attrezzo e la struttura di riciclaggio, rivolgerti alle proprie autorità locali.
- EL Διατηρήστε τον περιβάλλοντα καθαρό με τη σωστή απόθεση των προϊόντων (EUROPEAN). Συζητήστε με τις τοπικές αρχές για πληροφορίες σχετικά με τον καθαρισμό και την απόθεση.
- ES Mantén el medio ambiente limpio al disponer este producto con los residuos domésticos (EUROPEAN). Consulta de información acerca instalaciones de reciclaje.
- ET Hoidke keskkonda puhtaks: ära visake see toode koos teie koduse jäämääga (EUROPEAN). Kontrollige kohalike võimadega selle toote käsitsemise ja kõrvaldamise kohta.
- TH รักษาสิ่งแวดล้อมอย่าทิ้งของกับขยะบ้าน (EUROPEAN). ติดต่อหน่วยงานท้องถิ่นเพื่อขอคำแนะนำและข้อมูลเกี่ยวกับการกำจัดของใช้.

- EN Please do not discard by not disposing of this product with your household waste (EUROPEAN). Check with your local authority for recycling advice and facilities.
- DE Behalten Sie die Umhüllend und abzugeben die lokale Behälter nicht mit Ihrem Haushalt (EUROPEAN). Informationen zu Recycling-Möglichkeiten erhalten Sie bei den örtlichen Behörden.
- FR Protégez l'environnement: ne jetez pas ce produit avec vos autres déchets ménagers (EUROPEAN). Consultez les autorités locales pour obtenir des informations sur le recyclage et connaître les points de collecte.
- IT Proteggi l'ambiente! Non smaltire questo prodotto con i rifiuti domestici (EUROPEAN). Per informazioni sul riciclaggio dell'attrezzo e la struttura di riciclaggio, rivolgerti alle proprie autorità locali.
- EL Διατηρήστε τον περιβάλλοντα καθαρό με τη σωστή απόθεση των προϊόντων (EUROPEAN). Συζητήστε με τις τοπικές αρχές για πληροφορίες σχετικά με τον καθαρισμό και την απόθεση.
- ES Mantén el medio ambiente limpio al disponer este producto con los residuos domésticos (EUROPEAN). Consulta de información acerca instalaciones de reciclaje.
- ET Hoidke keskkonda puhtaks: ära visake see toode koos teie koduse jäämääga (EUROPEAN). Kontrollige kohalike võimadega selle toote käsitsemise ja kõrvaldamise kohta.
- TH รักษาสิ่งแวดล้อมอย่าทิ้งของกับขยะบ้าน (EUROPEAN). ติดต่อหน่วยงานท้องถิ่นเพื่อขอคำแนะนำและข้อมูลเกี่ยวกับการกำจัดของใช้.
- FR Protégez l'environnement: ne jetez pas ce produit avec vos autres déchets ménagers (EUROPEAN). Consultez les autorités locales pour obtenir des informations sur le recyclage et connaître les points de collecte.
- DE Behalten Sie die Umhüllend und abzugeben die lokale Behälter nicht mit Ihrem Haushalt (EUROPEAN). Informationen zu Recycling-Möglichkeiten erhalten Sie bei den örtlichen Behörden.
- FR Protégez l'environnement: ne jetez pas ce produit avec vos autres déchets ménagers (EUROPEAN). Consultez les autorités locales pour obtenir des informations sur le recyclage et connaître les points de collecte.
- IT Proteggi l'ambiente! Non smaltire questo prodotto con i rifiuti domestici (EUROPEAN). Per informazioni sul riciclaggio dell'attrezzo e la struttura di riciclaggio, rivolgerti alle proprie autorità locali.
- EL Διατηρήστε τον περιβάλλοντα καθαρό με τη σωστή απόθεση των προϊόντων (EUROPEAN). Συζητήστε με τις τοπικές αρχές για πληροφορίες σχετικά με τον καθαρισμό και την απόθεση.
- ES Mantén el medio ambiente limpio al disponer este producto con los residuos domésticos (EUROPEAN). Consulta de información acerca instalaciones de reciclaje.
- ET Hoidke keskkonda puhtaks: ära visake see toode koos teie koduse jäämääga (EUROPEAN). Kontrollige kohalike võimadega selle toote käsitsemise ja kõrvaldamise kohta.
- TH รักษาสิ่งแวดล้อมอย่าทิ้งของกับขยะบ้าน (EUROPEAN). ติดต่อหน่วยงานท้องถิ่นเพื่อขอคำแนะนำและข้อมูลเกี่ยวกับการกำจัดของใช้.

- EN Please do not discard by not disposing of this product with your household waste (EUROPEAN). Check with your local authority for recycling advice and facilities.
- DE Behalten Sie die Umhüllend und abzugeben die lokale Behälter nicht mit Ihrem Haushalt (EUROPEAN). Informationen zu Recycling-Möglichkeiten erhalten Sie bei den örtlichen Behörden.
- FR Protégez l'environnement: ne jetez pas ce produit avec vos autres déchets ménagers (EUROPEAN). Consultez les autorités locales pour obtenir des informations sur le recyclage et connaître les points de collecte.
- IT Proteggi l'ambiente! Non smaltire questo prodotto con i rifiuti domestici (EUROPEAN). Per informazioni sul riciclaggio dell'attrezzo e la struttura di riciclaggio, rivolgerti alle proprie autorità locali.
- EL Διατηρήστε τον περιβάλλοντα καθαρό με τη σωστή απόθεση των προϊόντων (EUROPEAN). Συζητήστε με τις τοπικές αρχές για πληροφορίες σχετικά με τον καθαρισμό και την απόθεση.
- ES Mantén el medio ambiente limpio al disponer este producto con los residuos domésticos (EUROPEAN). Consulta de información acerca instalaciones de reciclaje.
- ET Hoidke keskkonda puhtaks: ära visake see toode koos teie koduse jäämääga (EUROPEAN). Kontrollige kohalike võimadega selle toote käsitsemise ja kõrvaldamise kohta.
- TH รักษาสิ่งแวดล้อมอย่าทิ้งของกับขยะบ้าน (EUROPEAN). ติดต่อหน่วยงานท้องถิ่นเพื่อขอคำแนะนำและข้อมูลเกี่ยวกับการกำจัดของใช้.
- FR Protégez l'environnement: ne jetez pas ce produit avec vos autres déchets ménagers (EUROPEAN). Consultez les autorités locales pour obtenir des informations sur le recyclage et connaître les points de collecte.
- DE Behalten Sie die Umhüllend und abzugeben die lokale Behälter nicht mit Ihrem Haushalt (EUROPEAN). Informationen zu Recycling-Möglichkeiten erhalten Sie bei den örtlichen Behörden.
- FR Protégez l'environnement: ne jetez pas ce produit avec vos autres déchets ménagers (EUROPEAN). Consultez les autorités locales pour obtenir des informations sur le recyclage et connaître les points de collecte.
- IT Proteggi l'ambiente! Non smaltire questo prodotto con i rifiuti domestici (EUROPEAN). Per informazioni sul riciclaggio dell'attrezzo e la struttura di riciclaggio, rivolgerti alle proprie autorità locali.
- EL Διατηρήστε τον περιβάλλοντα καθαρό με τη σωστή απόθεση των προϊόντων (EUROPEAN). Συζητήστε με τις τοπικές αρχές για πληροφορίες σχετικά με τον καθαρισμό και την απόθεση.
- ES Mantén el medio ambiente limpio al disponer este producto con los residuos domésticos (EUROPEAN). Consulta de información acerca instalaciones de reciclaje.
- ET Hoidke keskkonda puhtaks: ära visake see toode koos teie koduse jäämääga (EUROPEAN). Kontrollige kohalike võimadega selle toote käsitsemise ja kõrvaldamise kohta.
- TH รักษาสิ่งแวดล้อมอย่าทิ้งของกับขยะบ้าน (EUROPEAN). ติดต่อหน่วยงานท้องถิ่นเพื่อขอคำแนะนำและข้อมูลเกี่ยวกับการกำจัดของใช้.

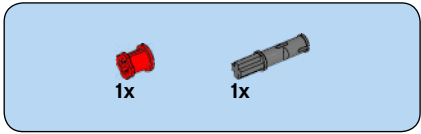

1

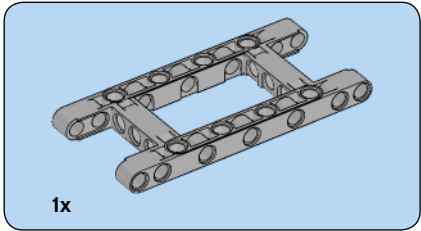
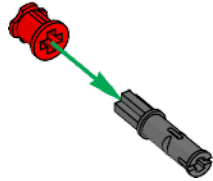

2

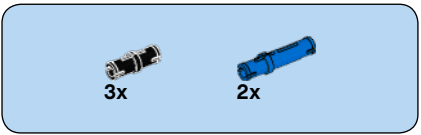
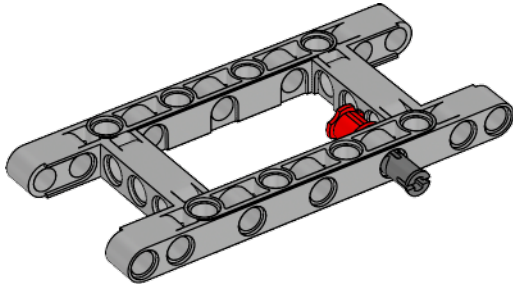

3

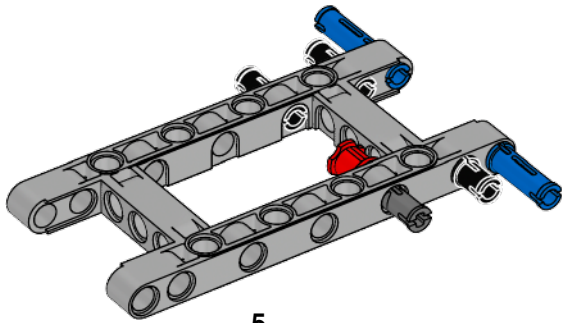

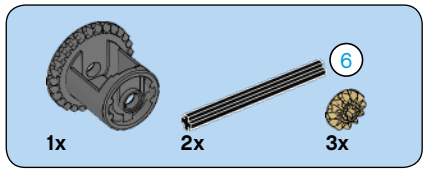

4

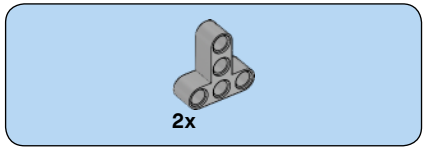
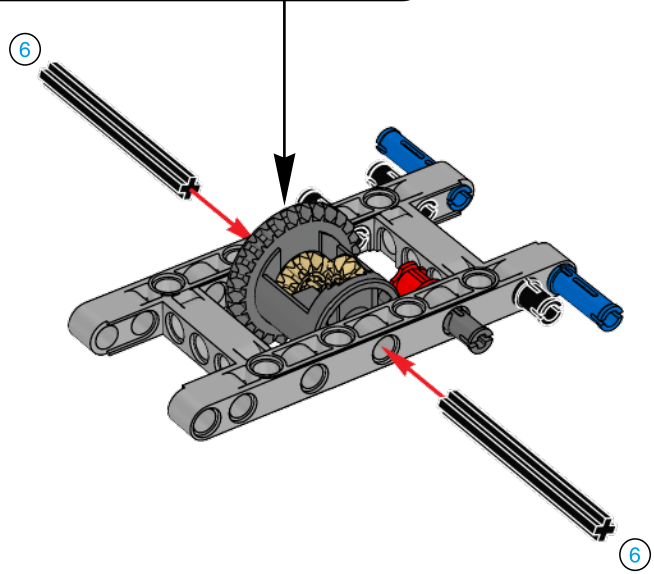
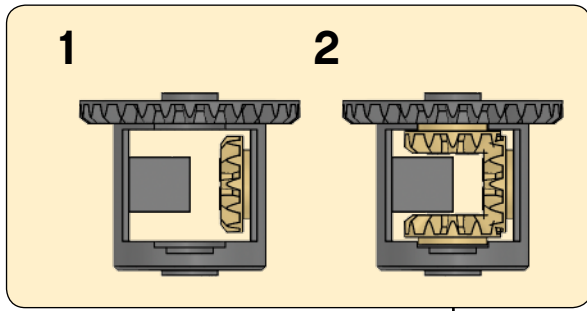

5

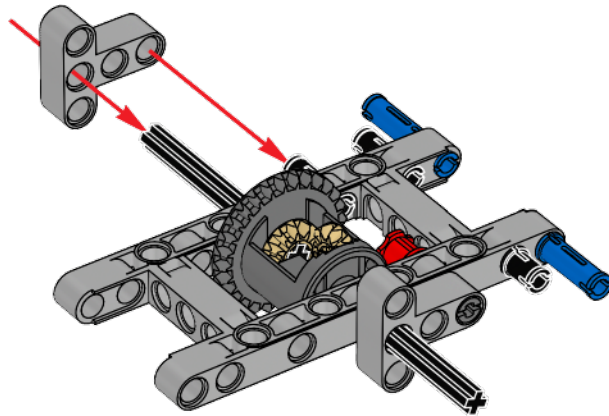



4x

6

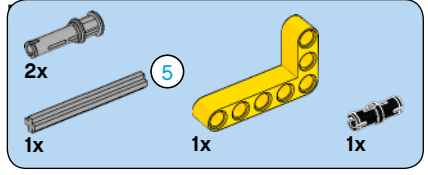
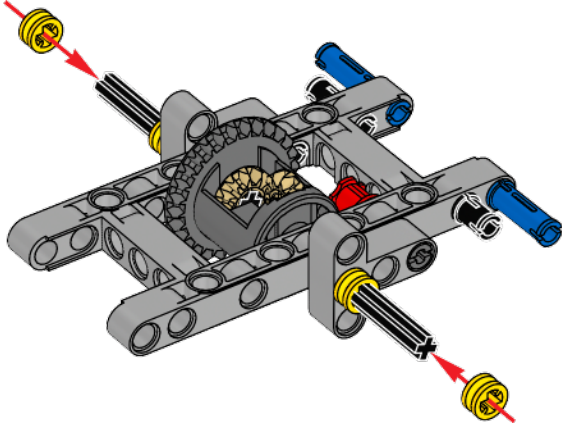

7

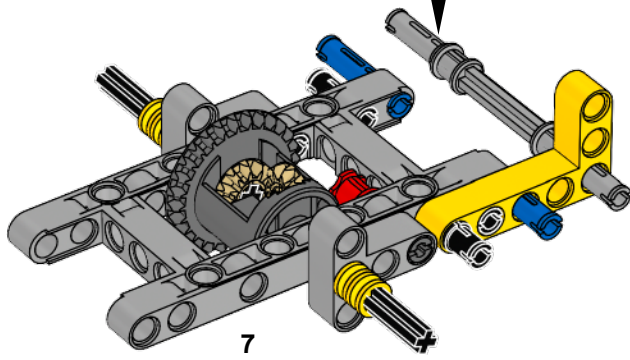
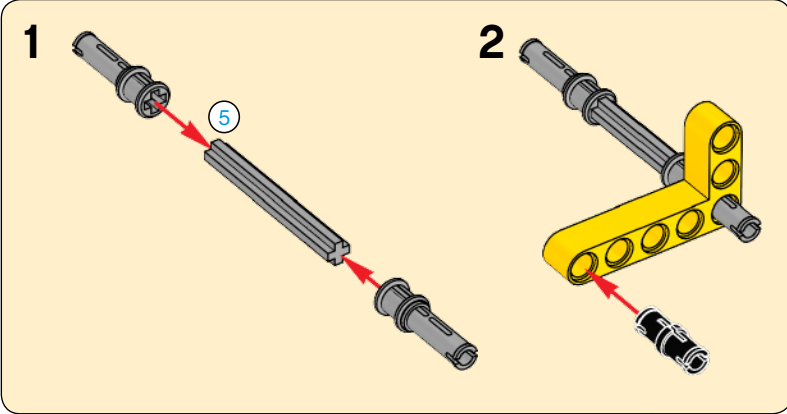

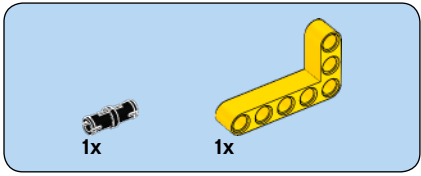

8

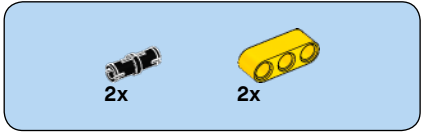
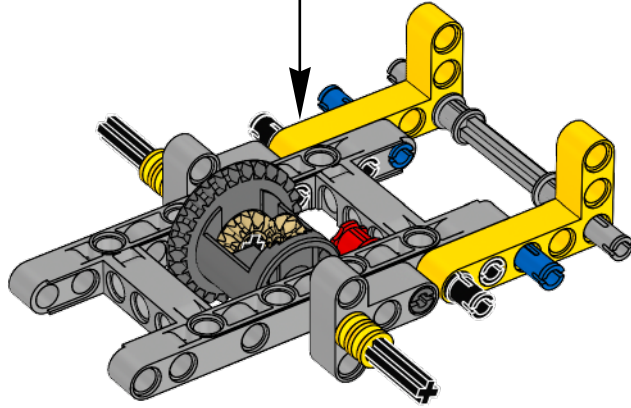
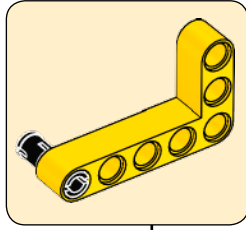

9

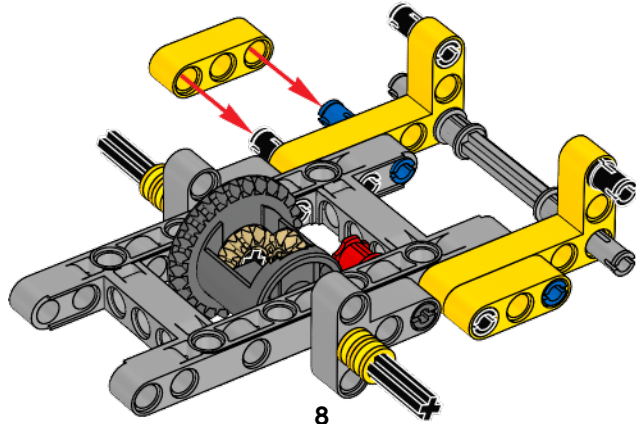

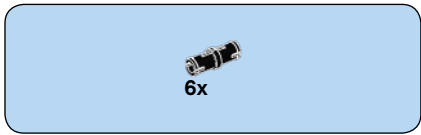

10

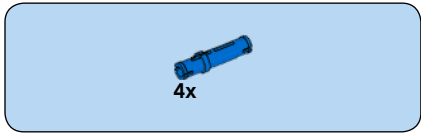
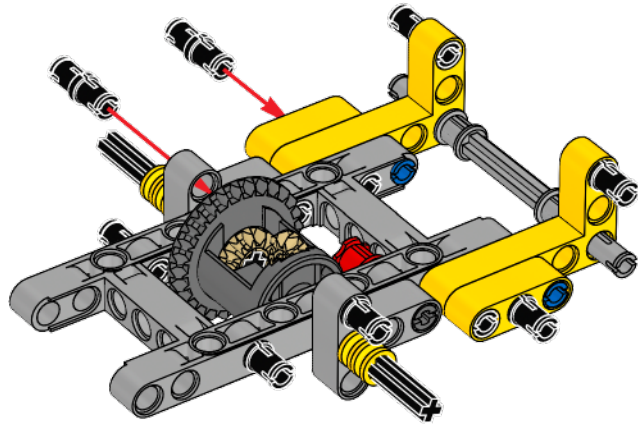

11

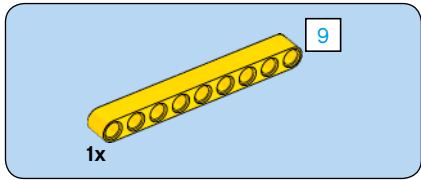
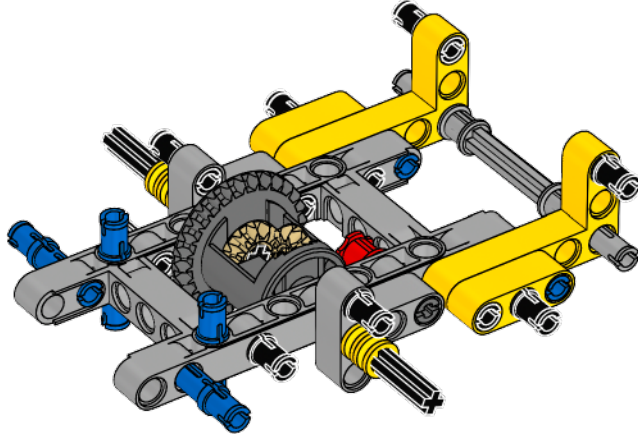

12

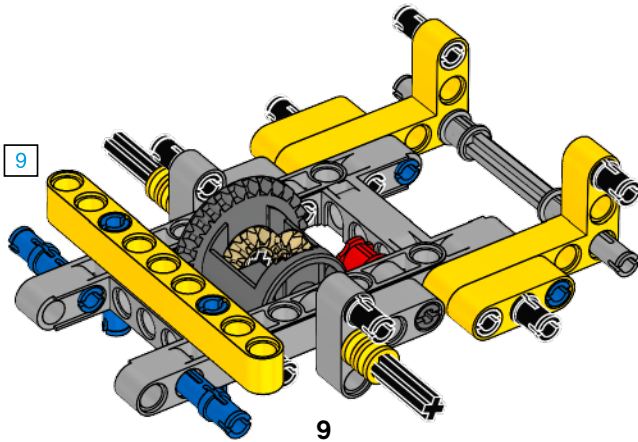

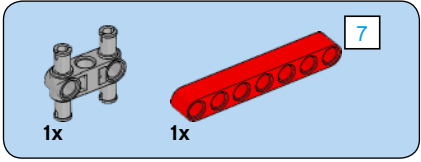
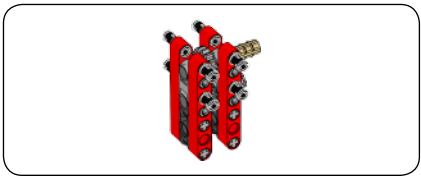

1

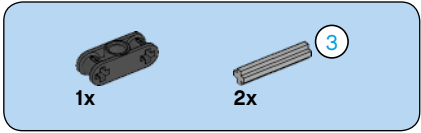
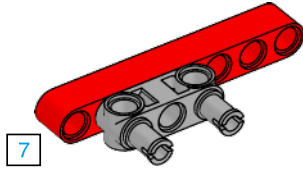

2

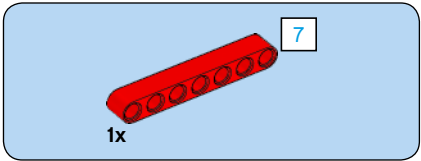
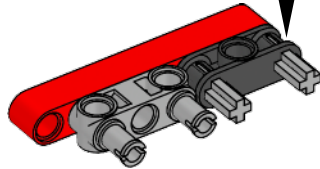
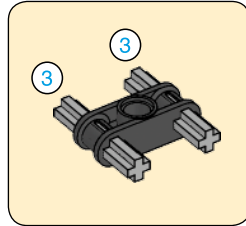

3

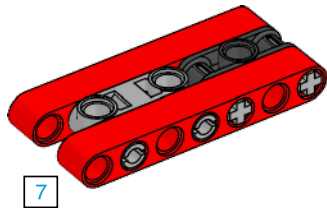

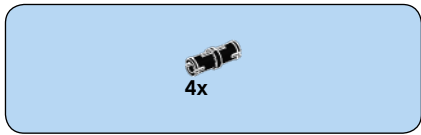

4

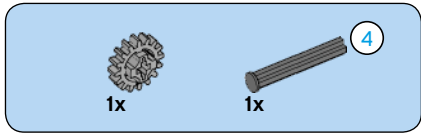
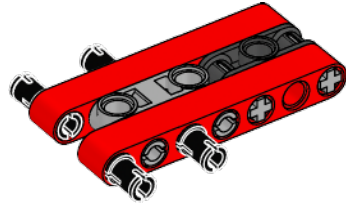

5

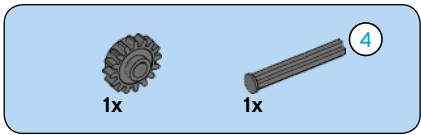
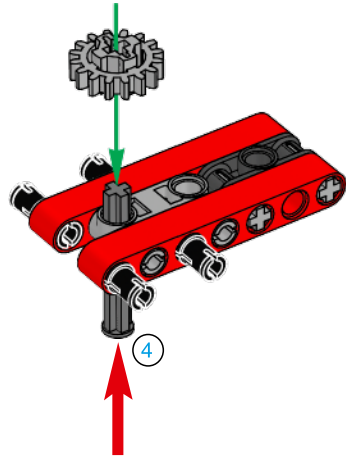

6

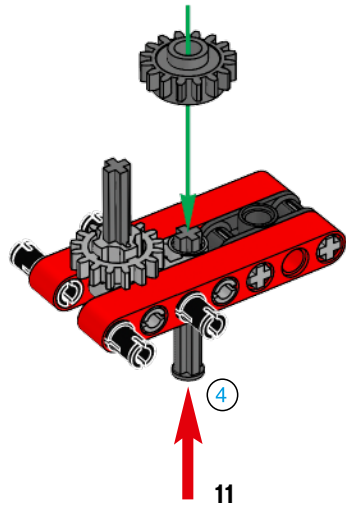

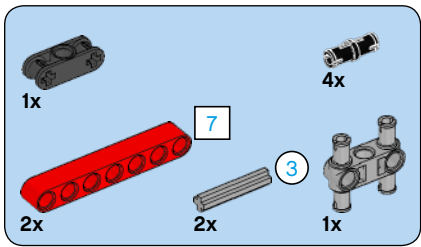

7

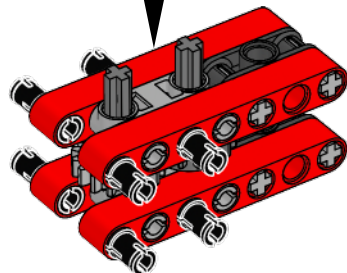
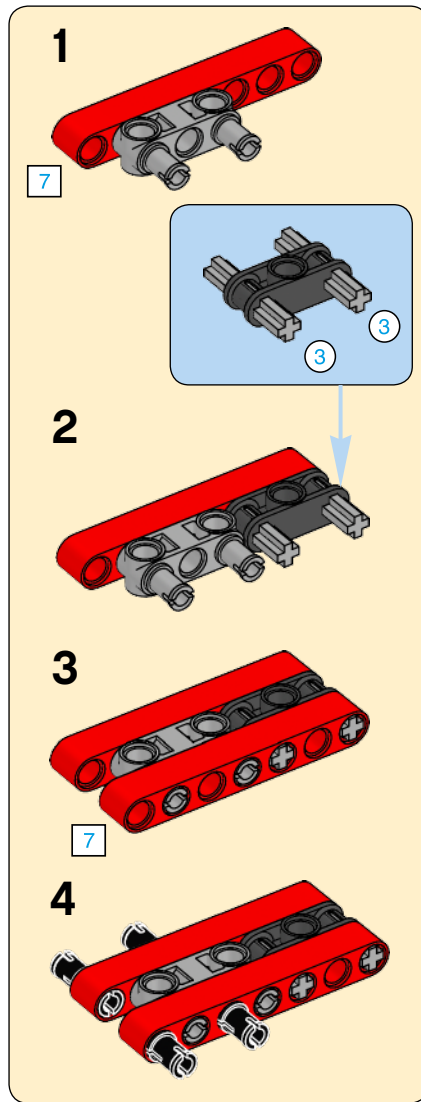

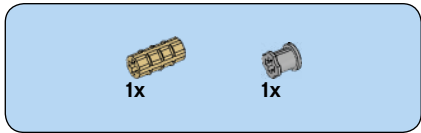

8

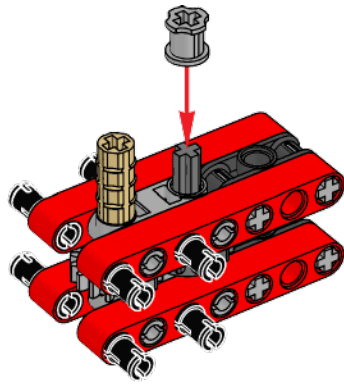

9

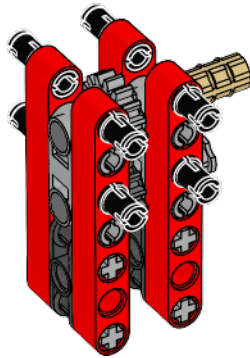

13

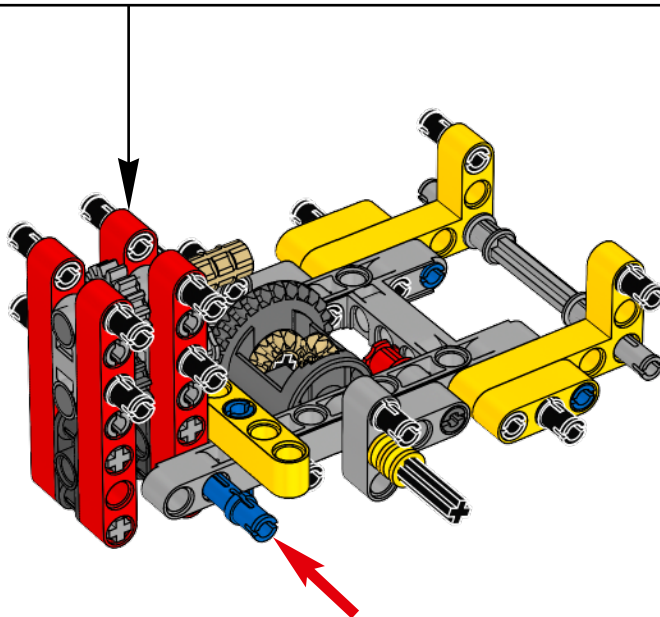

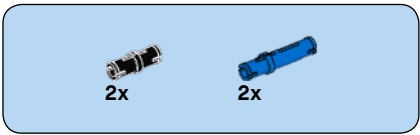

14

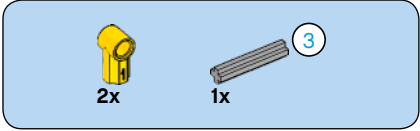
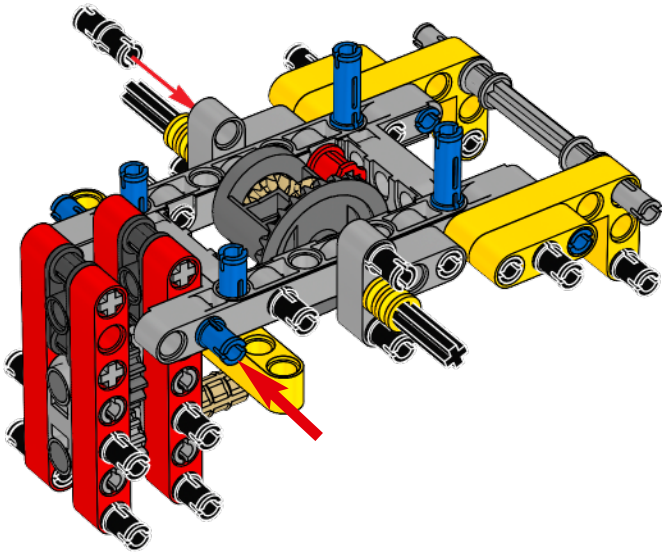

15

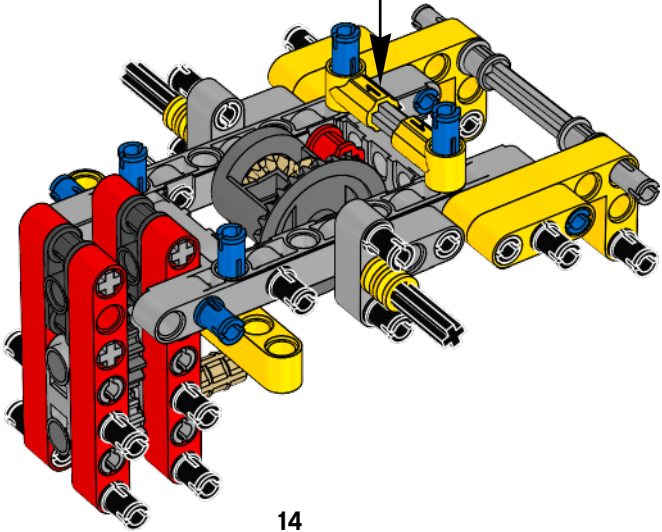
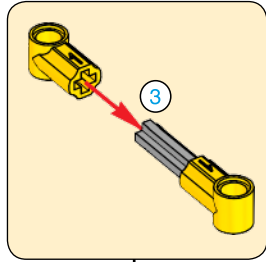

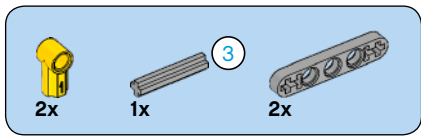

16

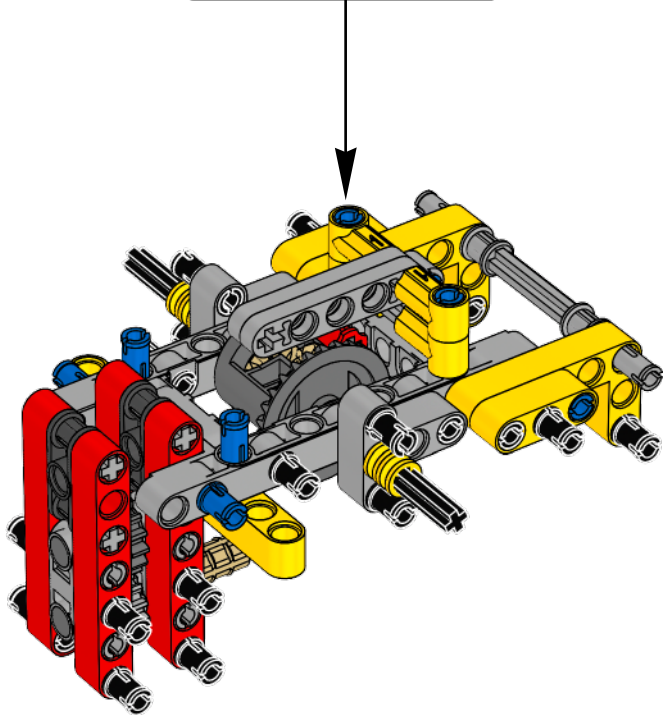
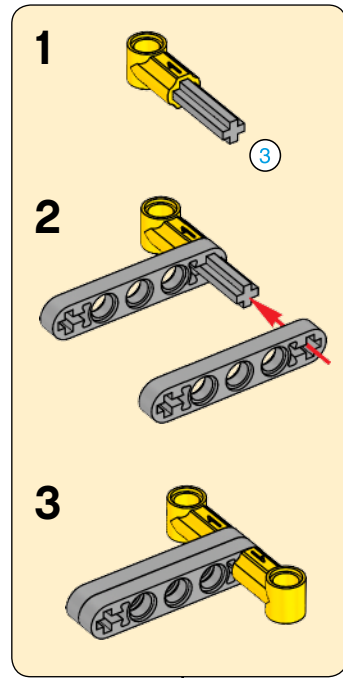

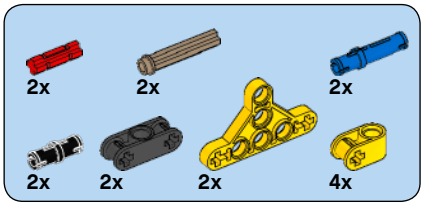

17

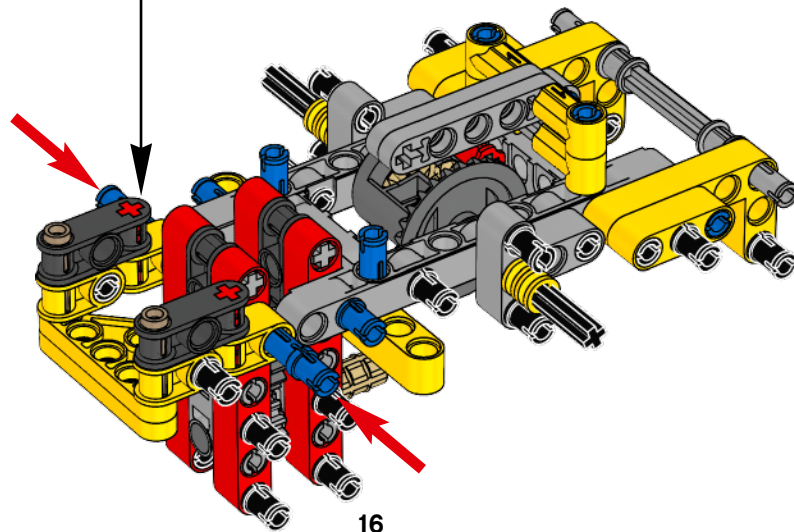
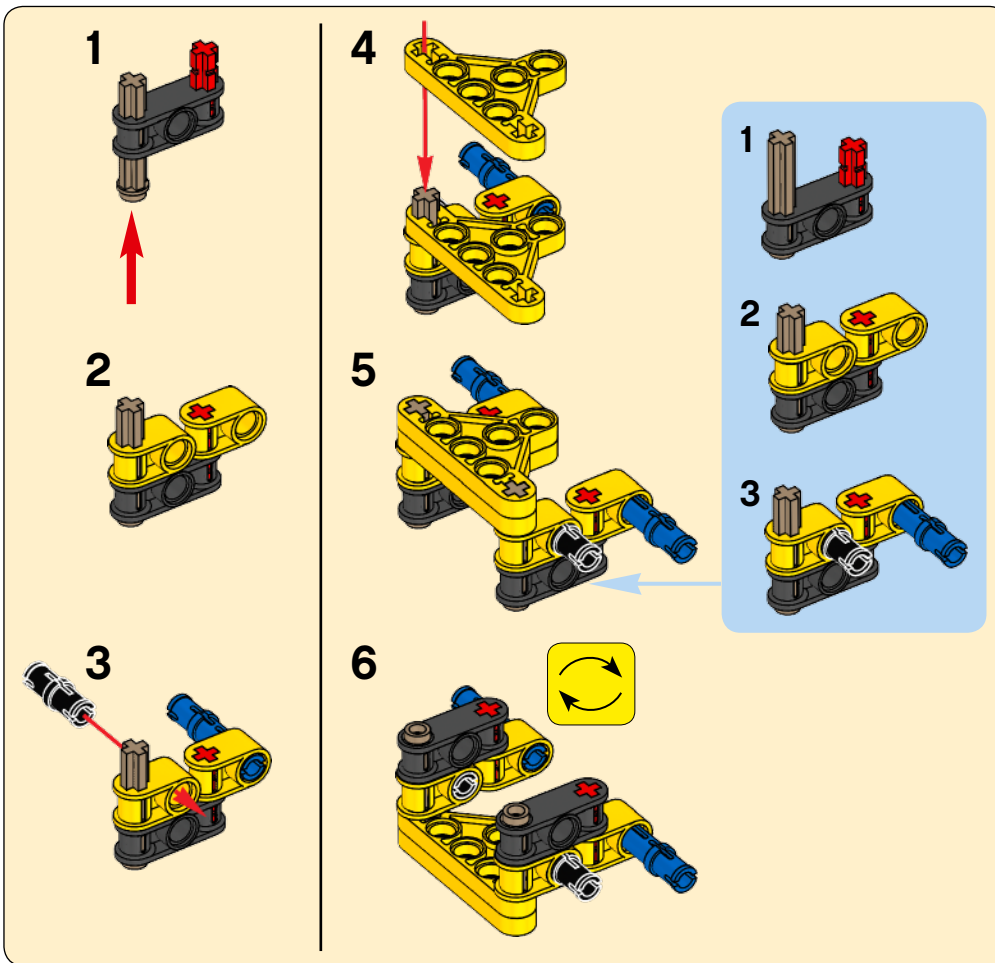

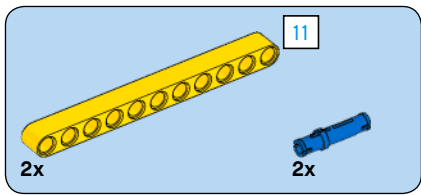

18

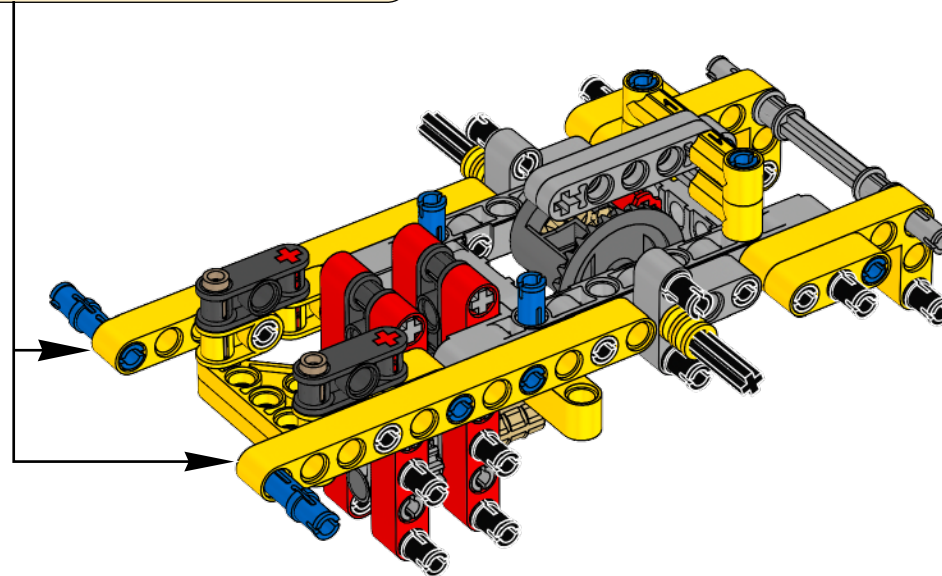
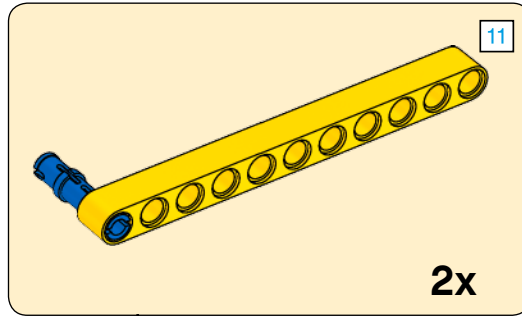

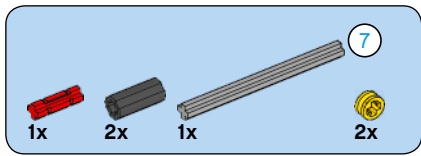

19

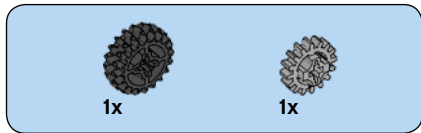
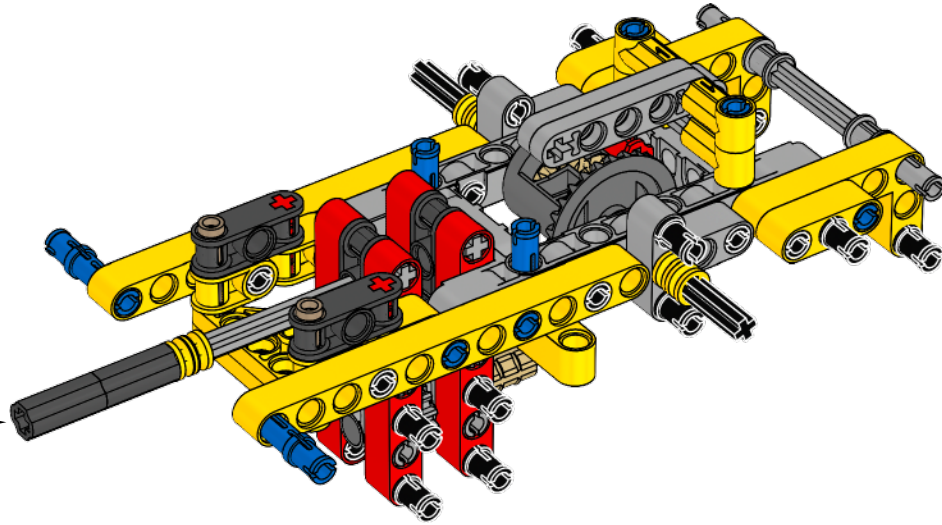
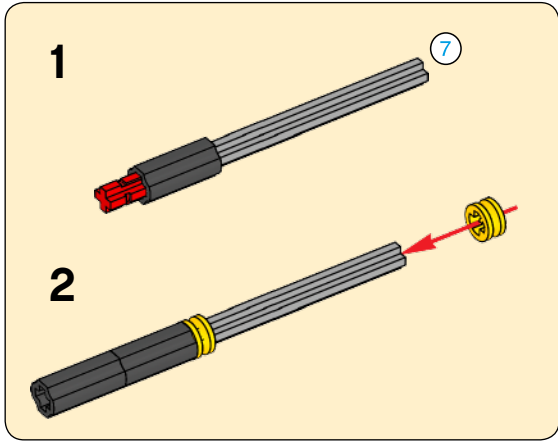

20

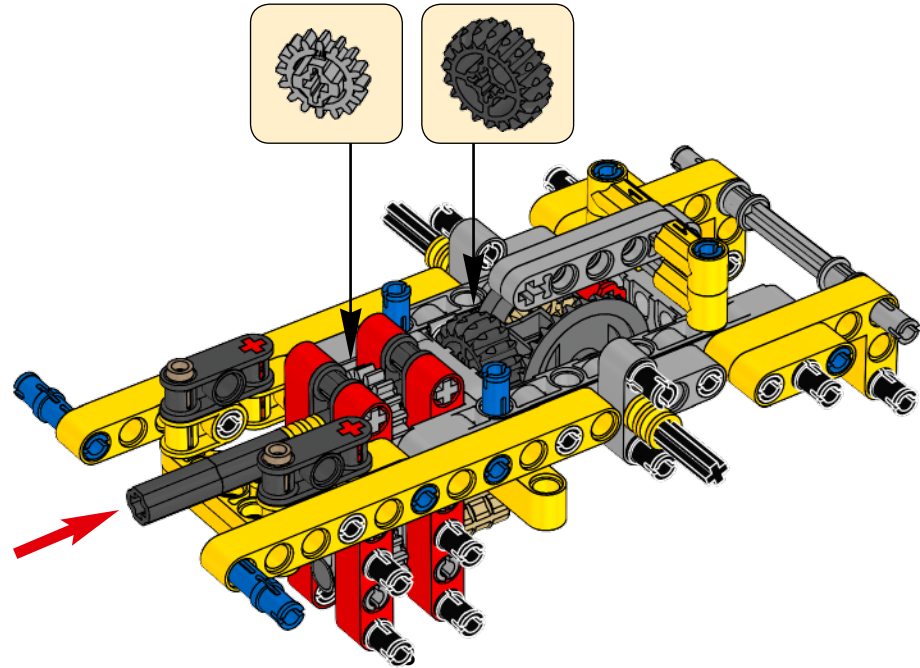

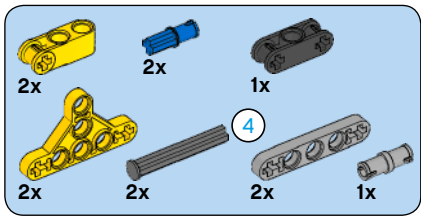

21

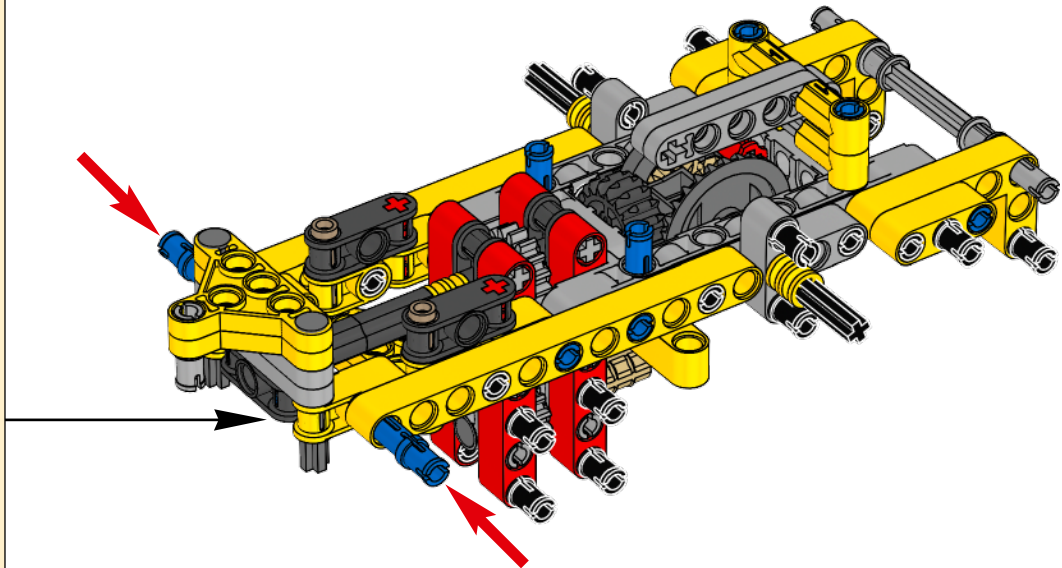
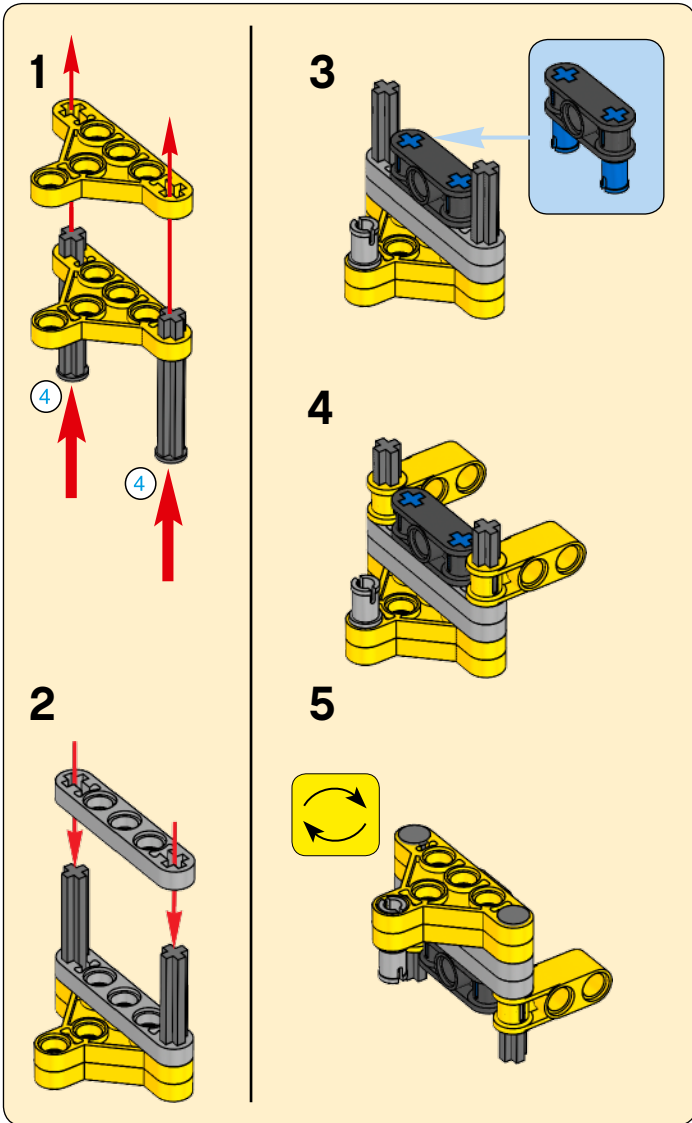

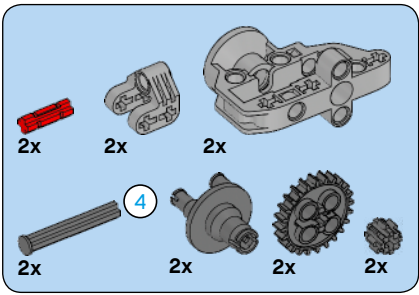

22

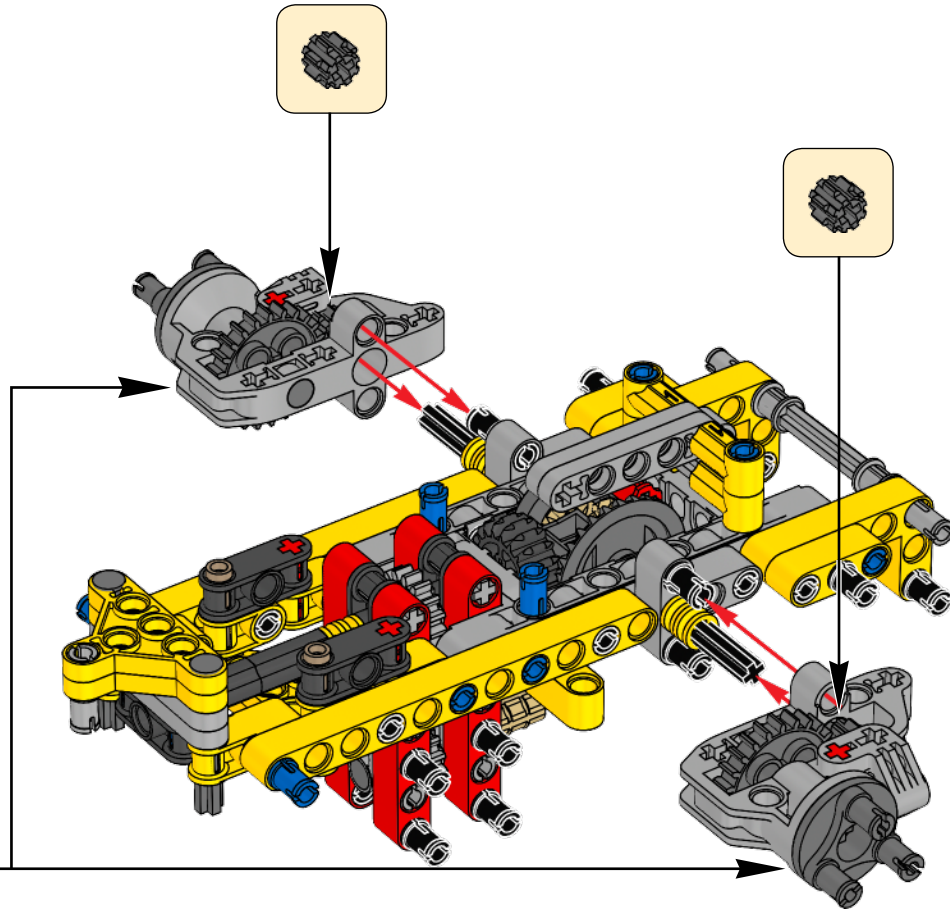
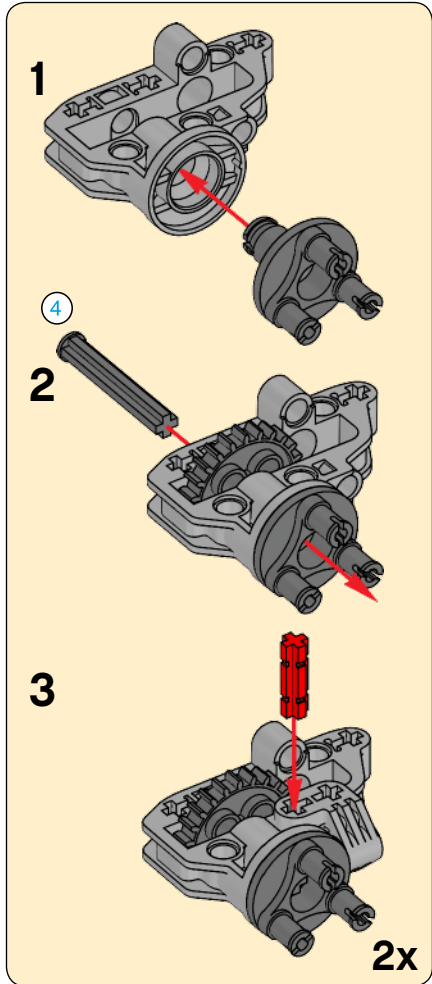

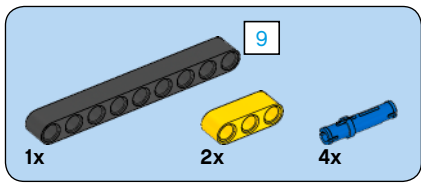

23

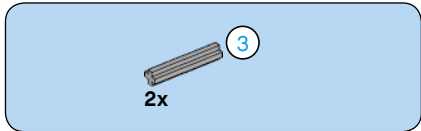
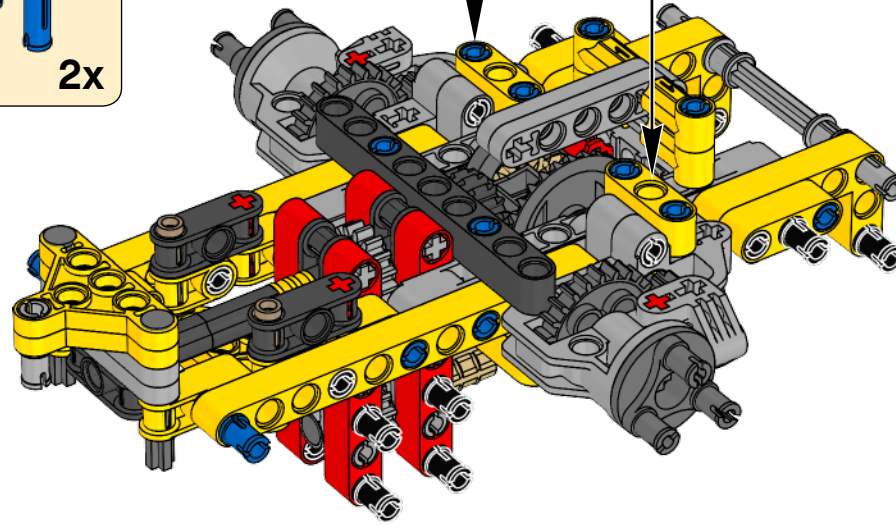
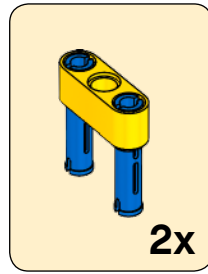

24

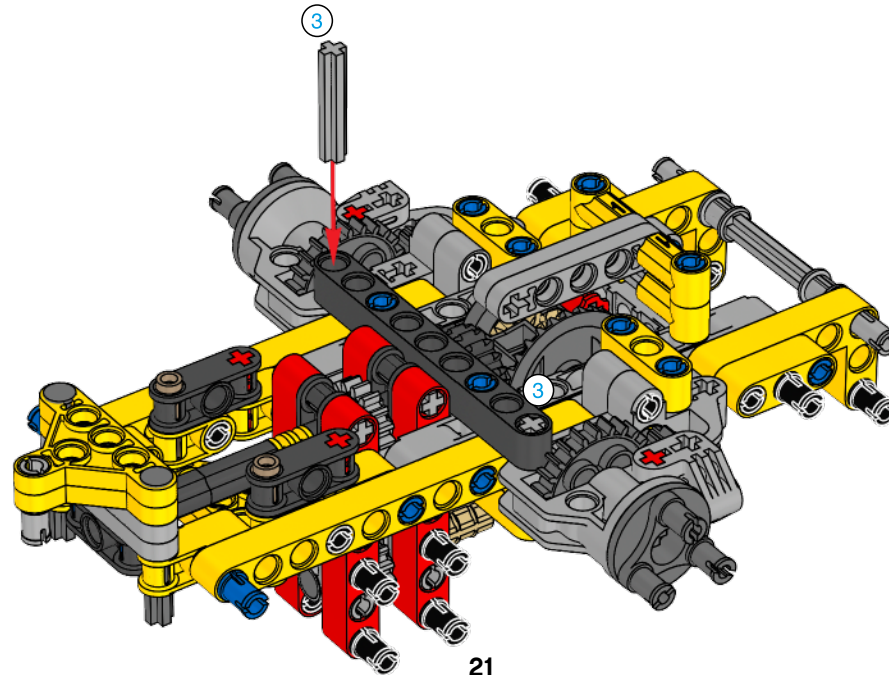

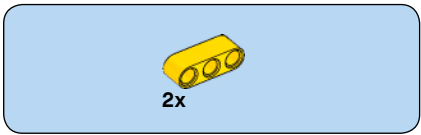

25

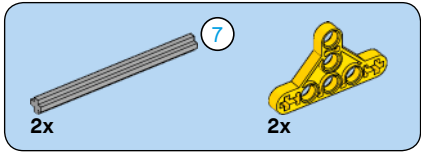
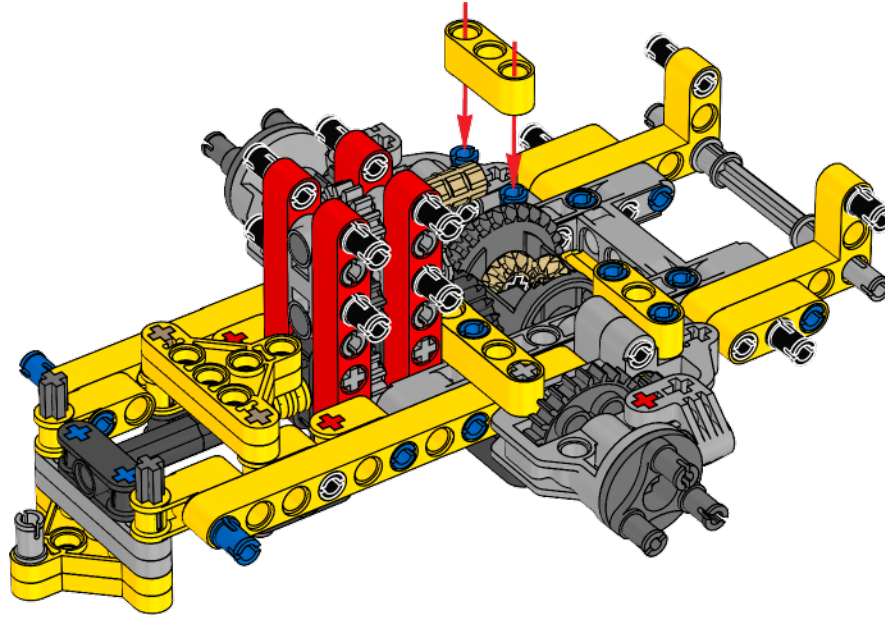

26

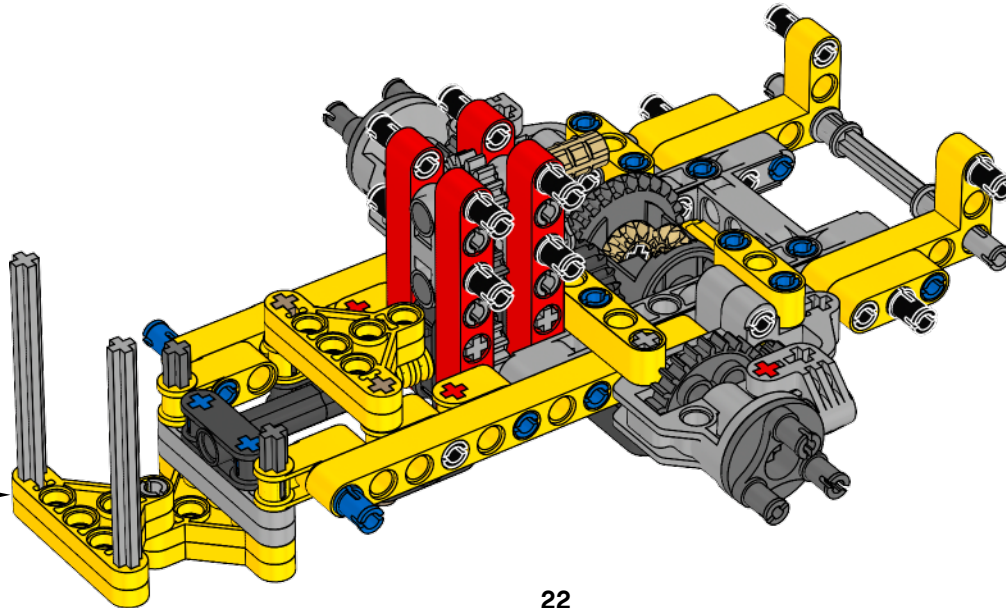
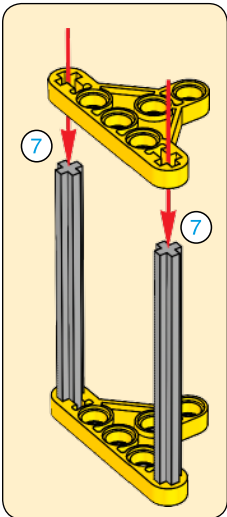

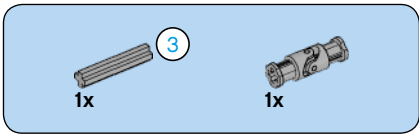

27

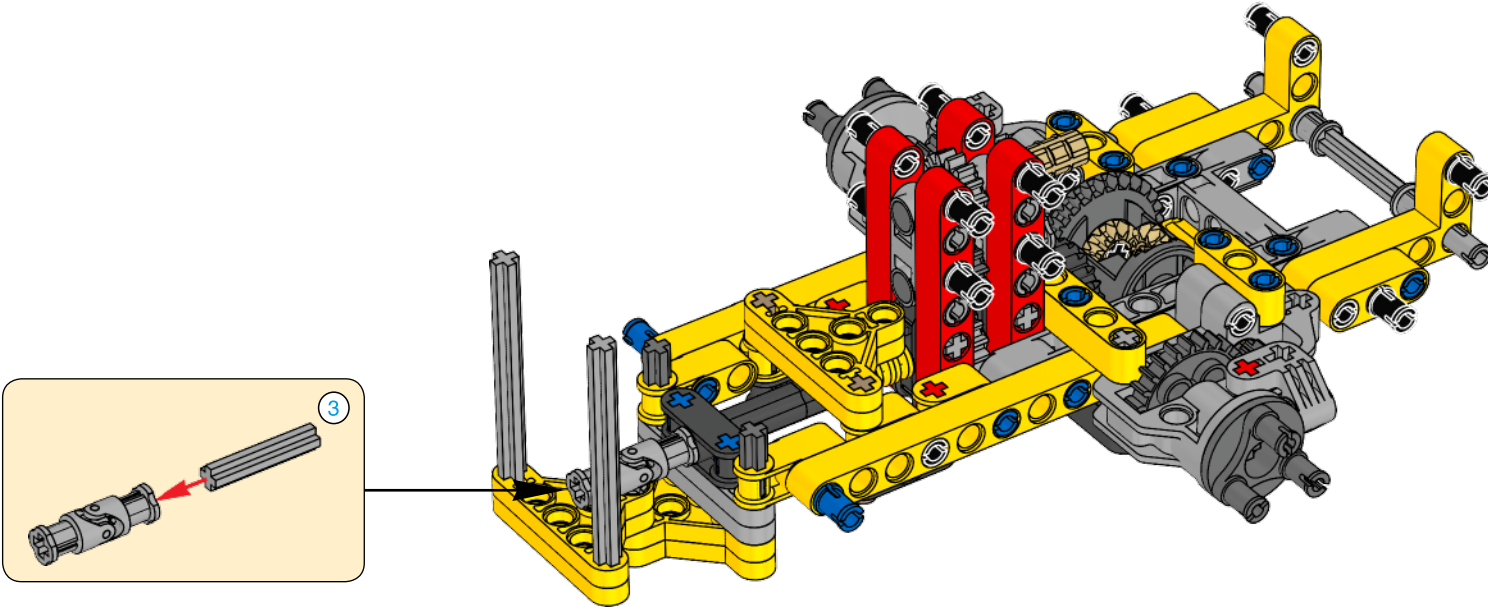

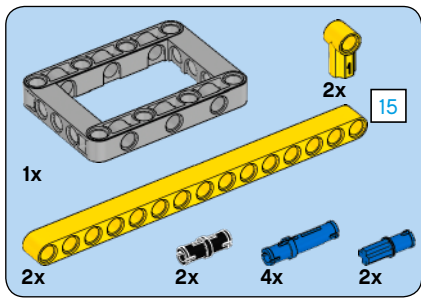

28

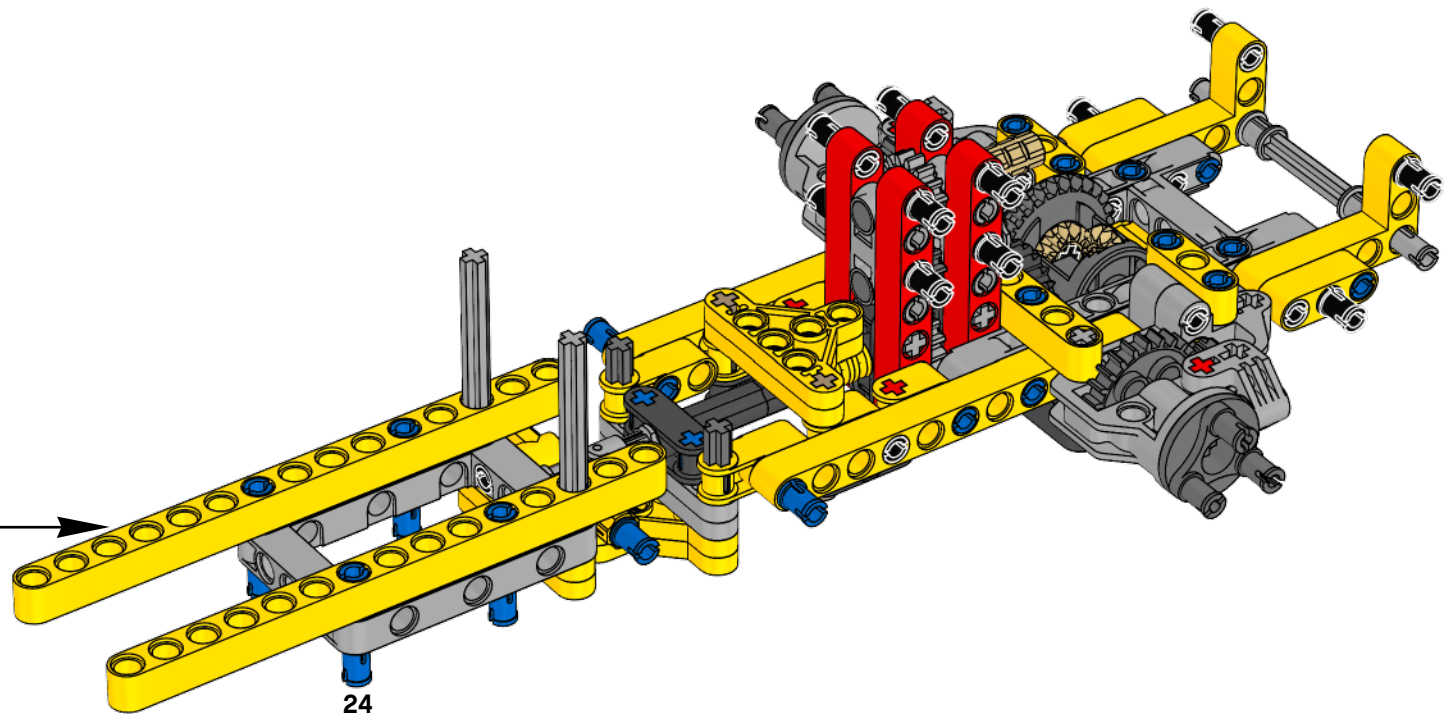
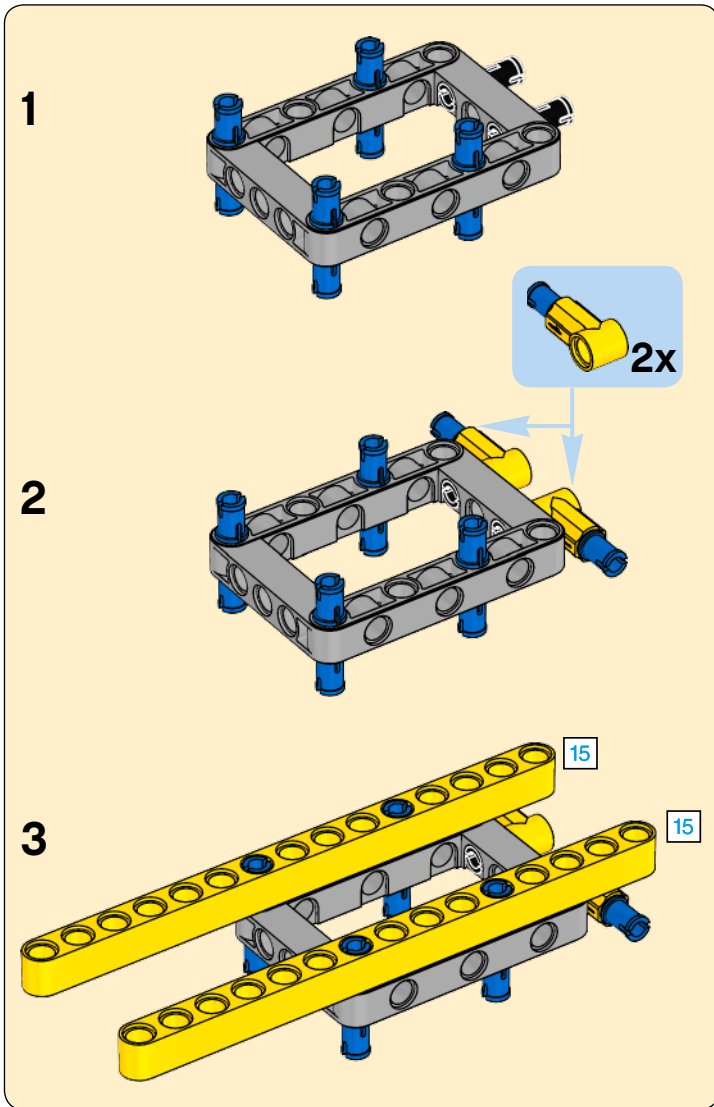

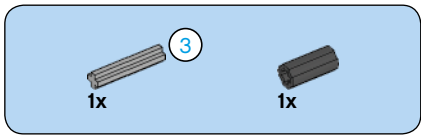

29

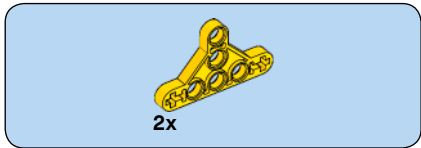
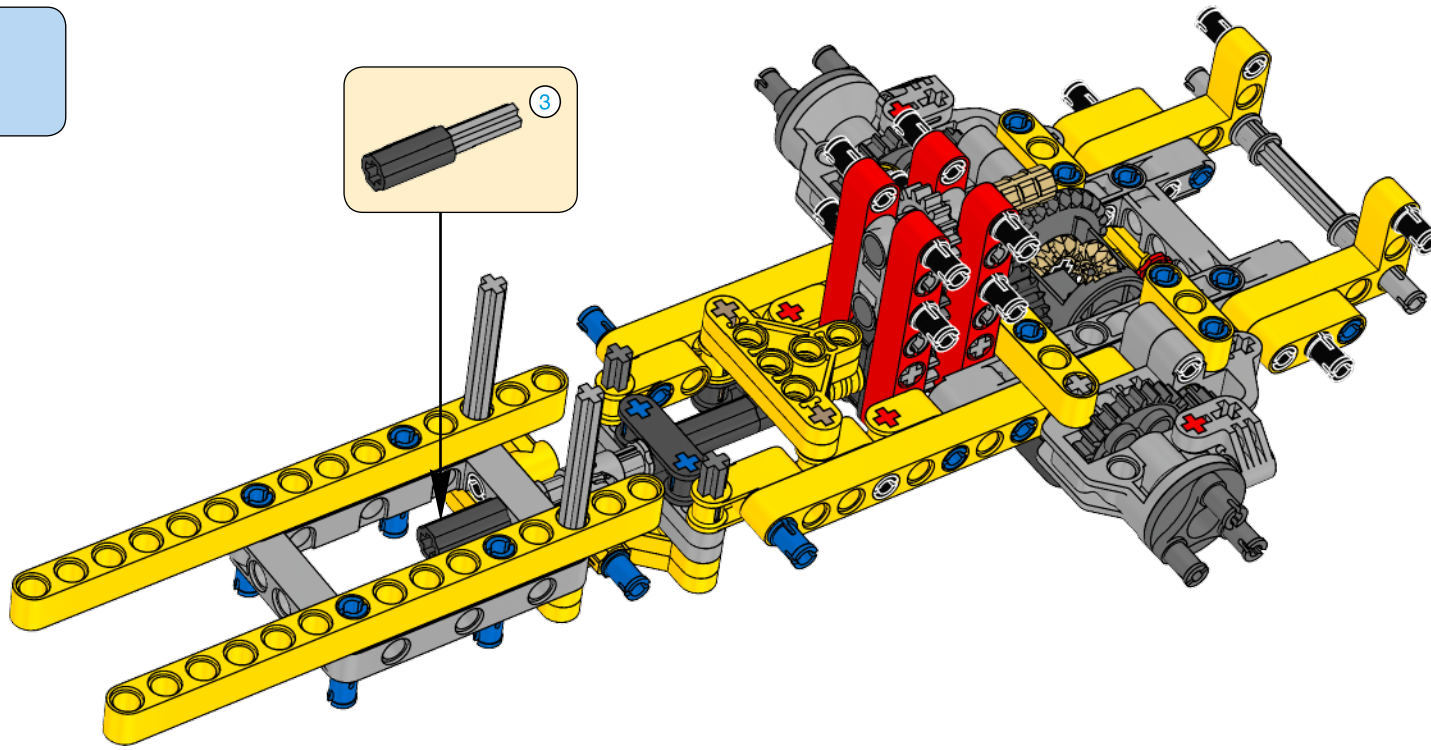

30

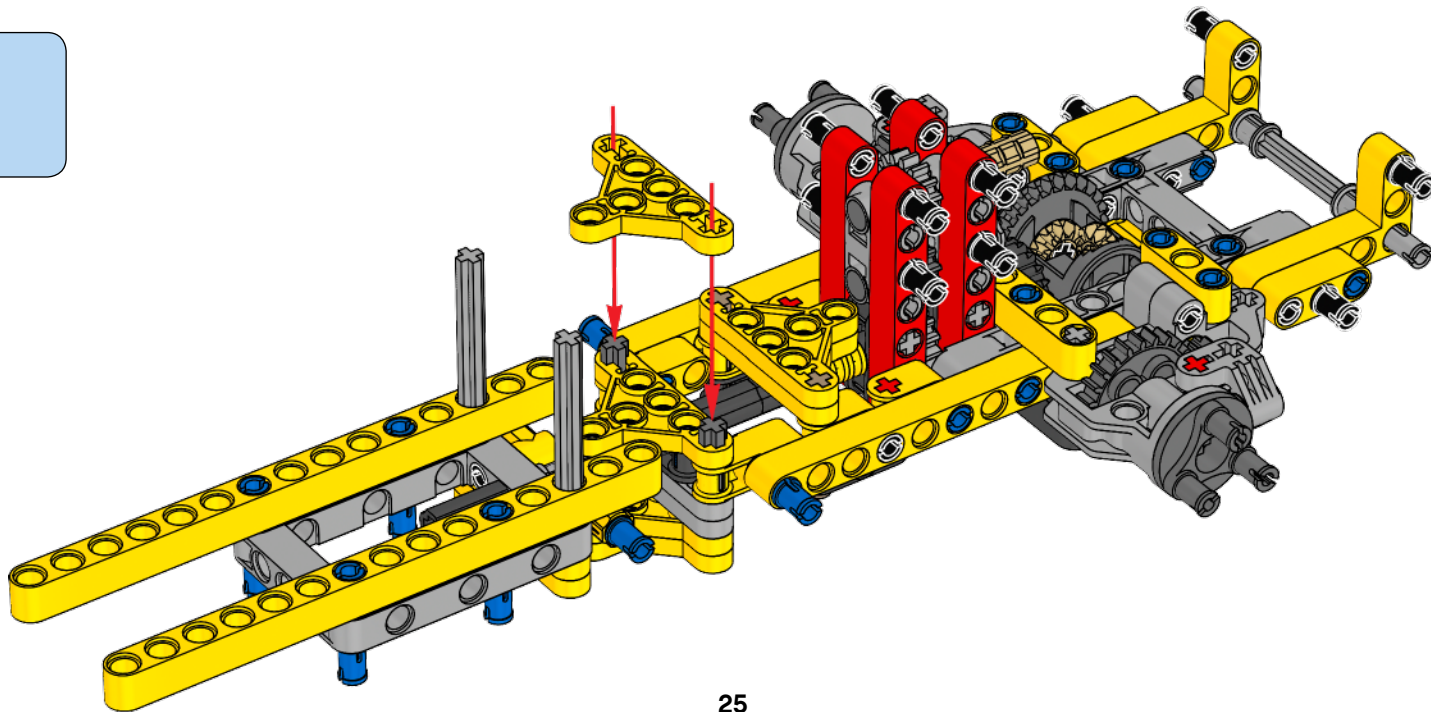

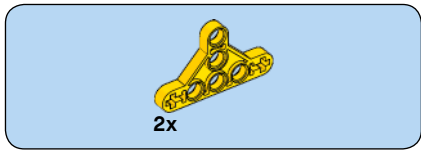

31

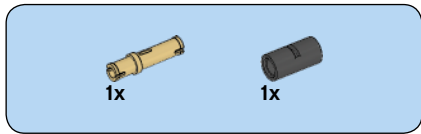
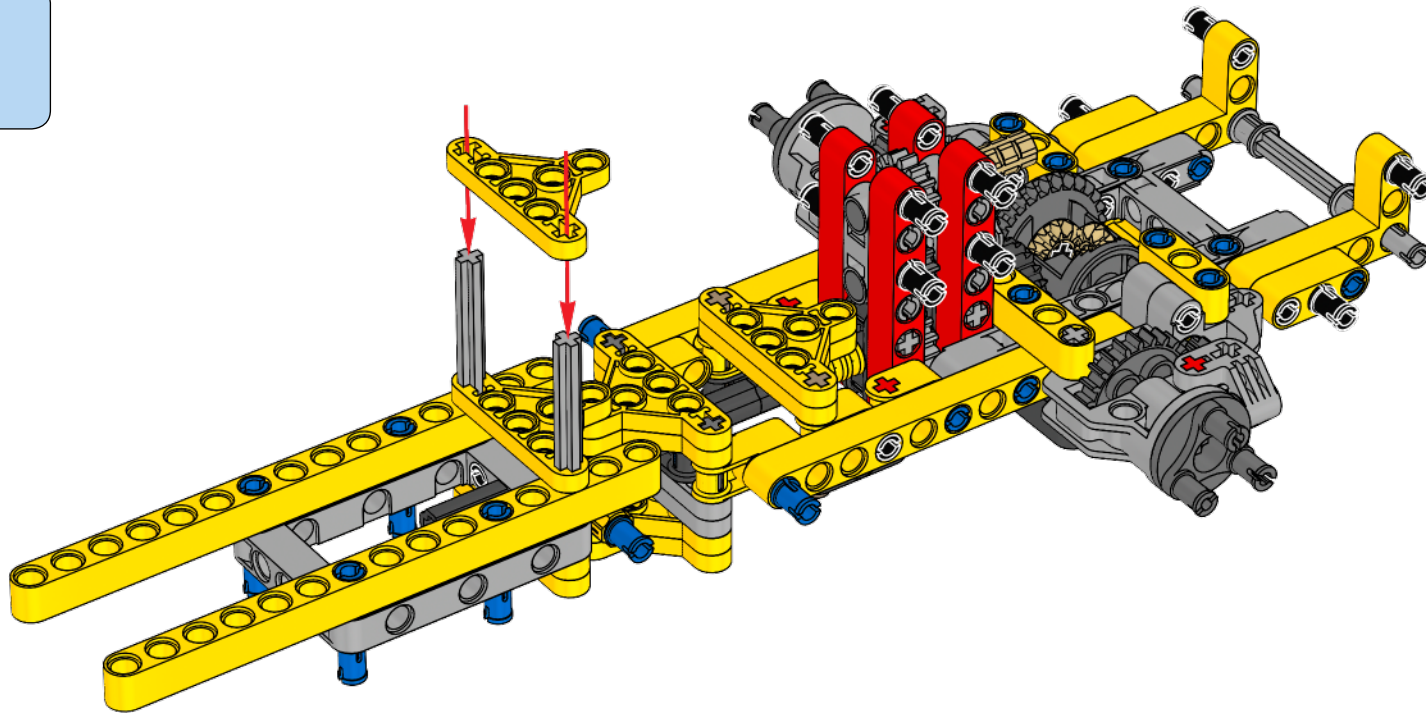

32

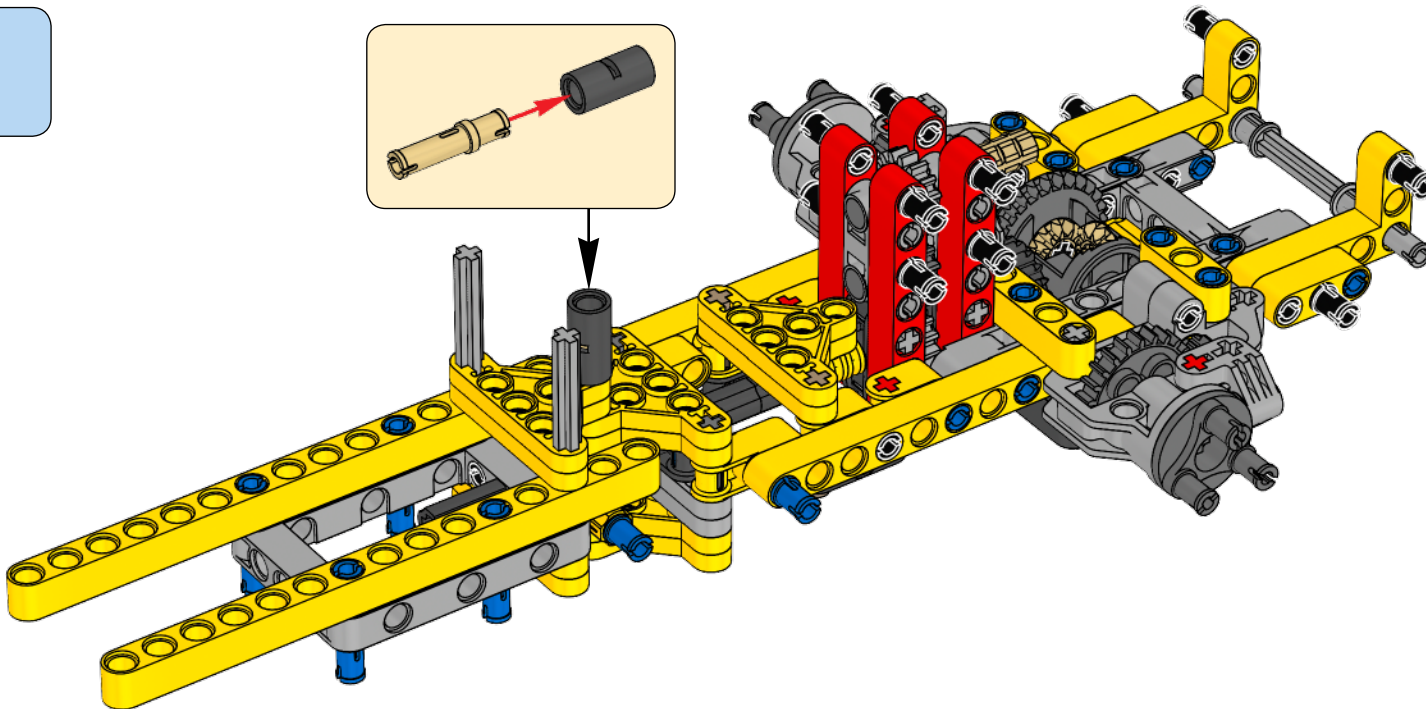
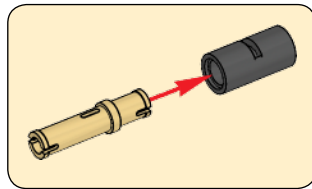

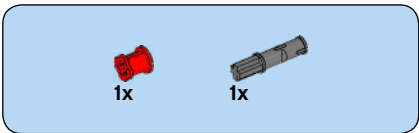
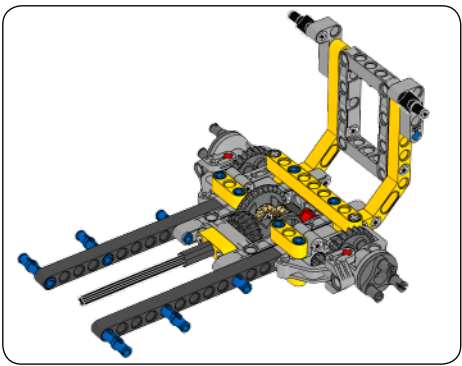

1

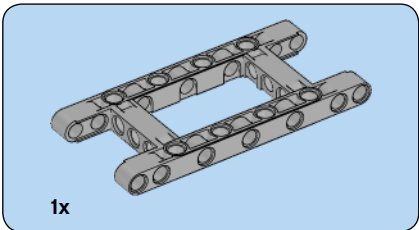
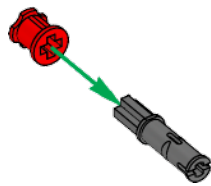

2

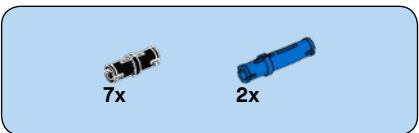
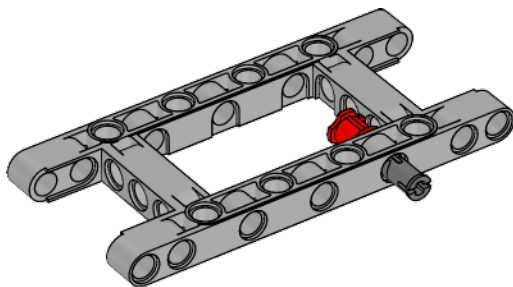

3

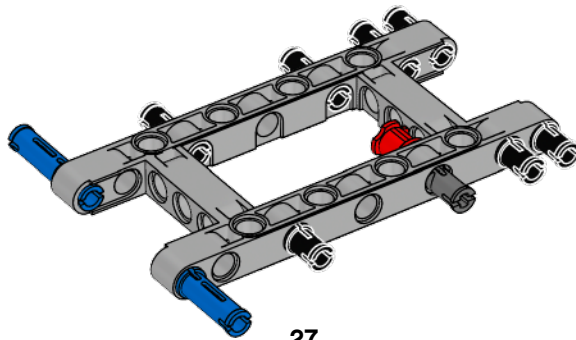

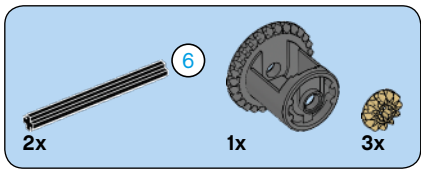

4

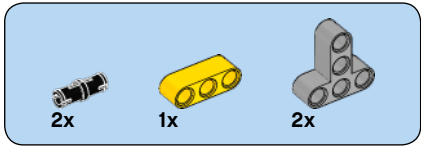
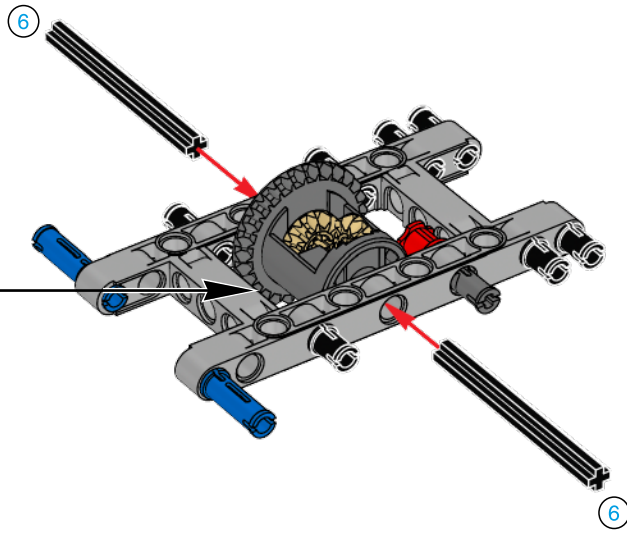
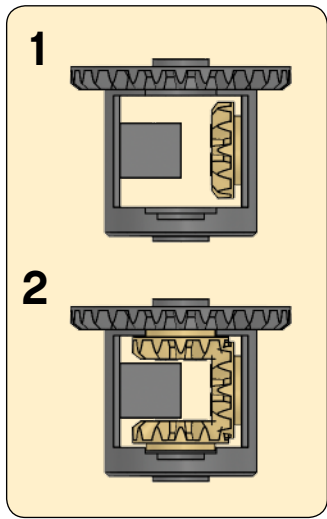

5

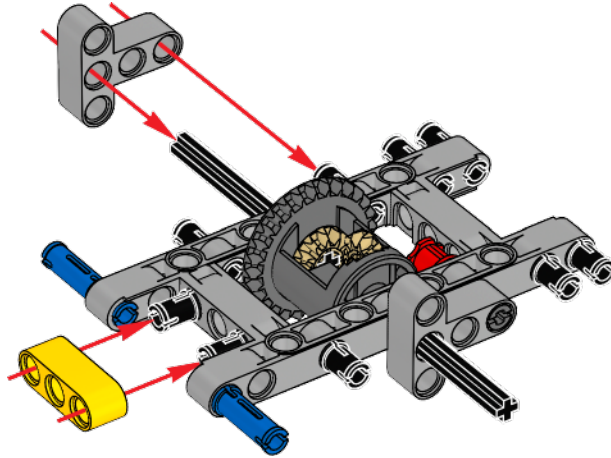

6

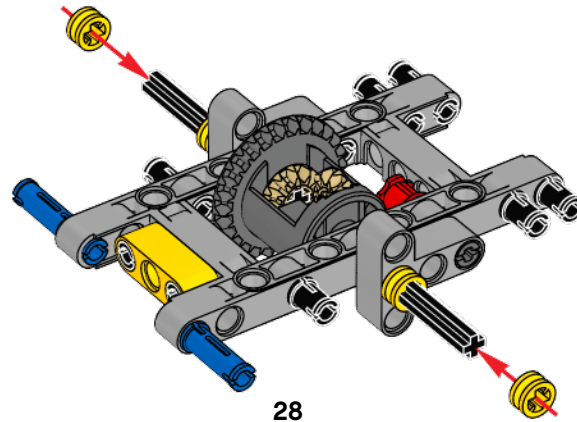

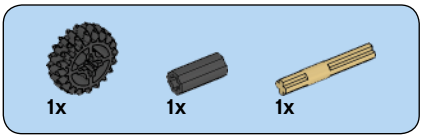

7

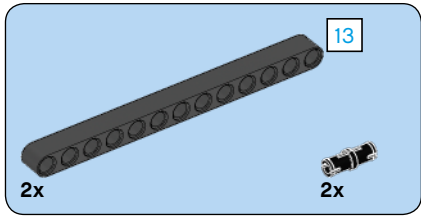
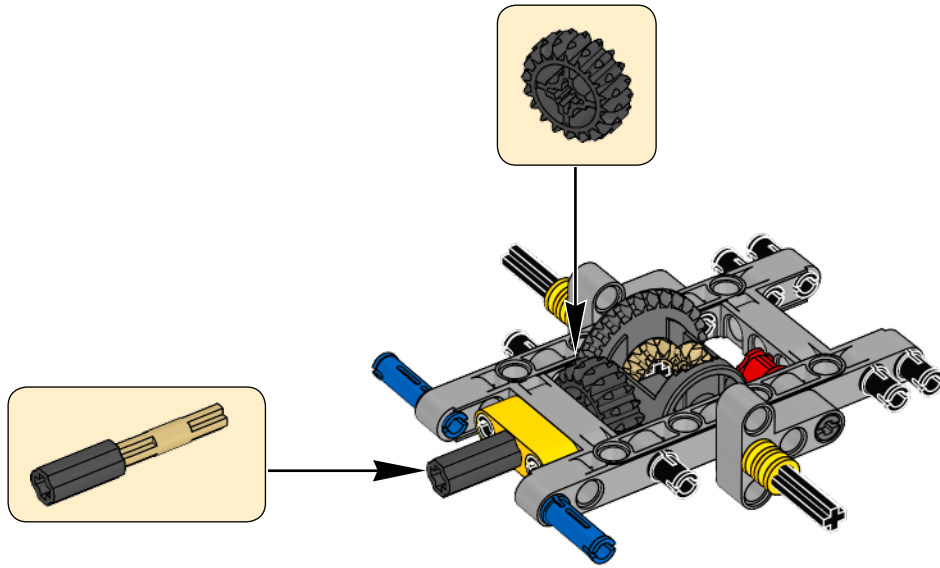

8

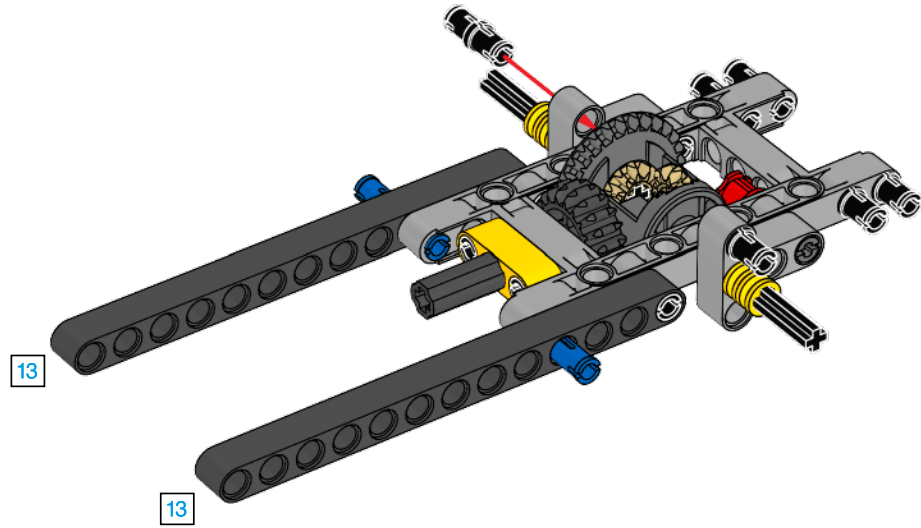

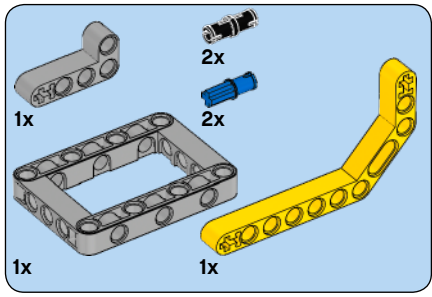

9

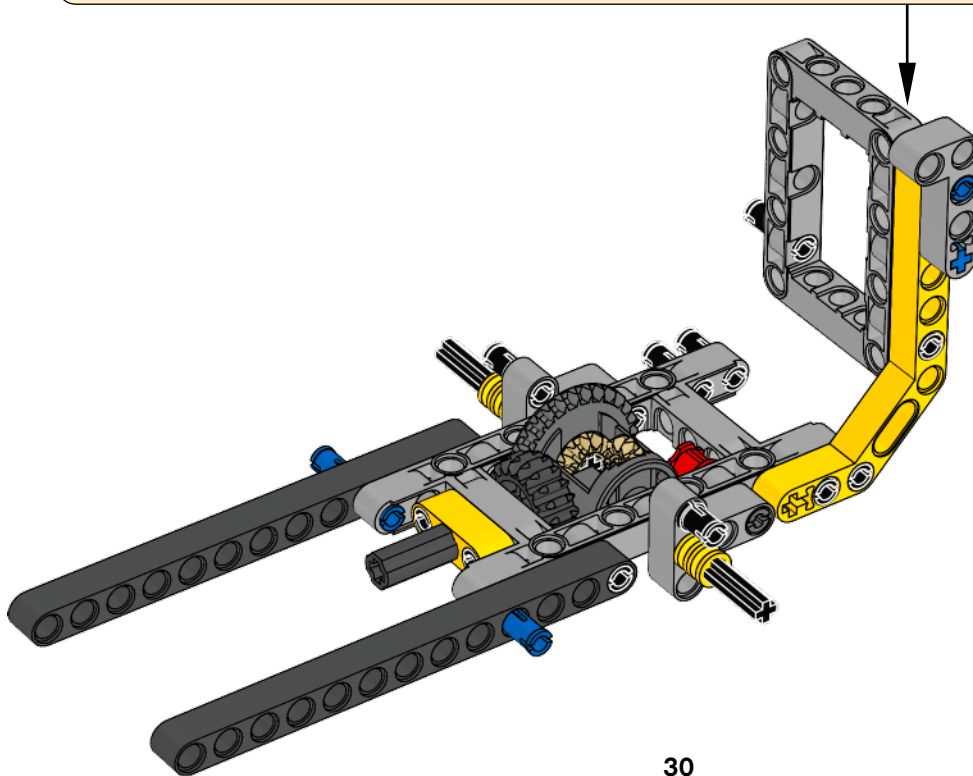
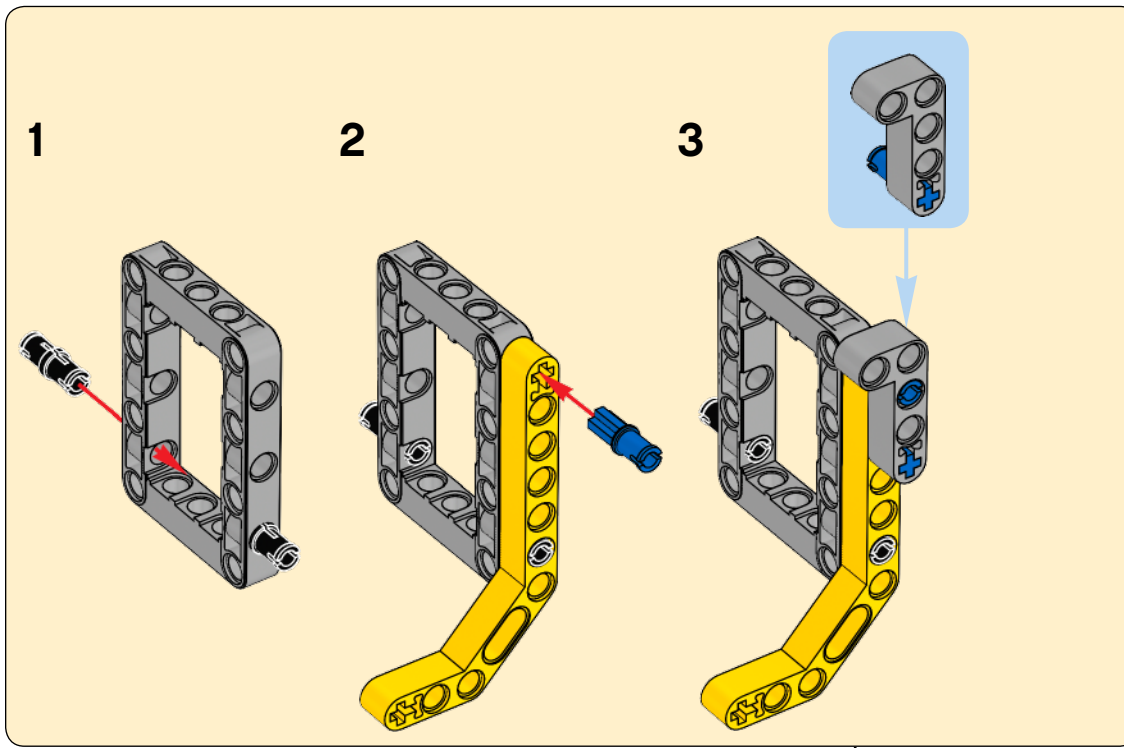

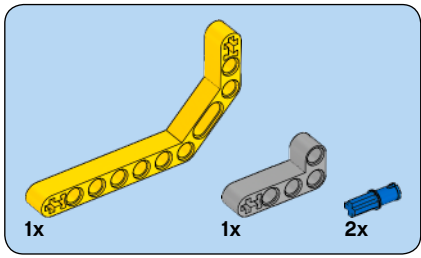

10

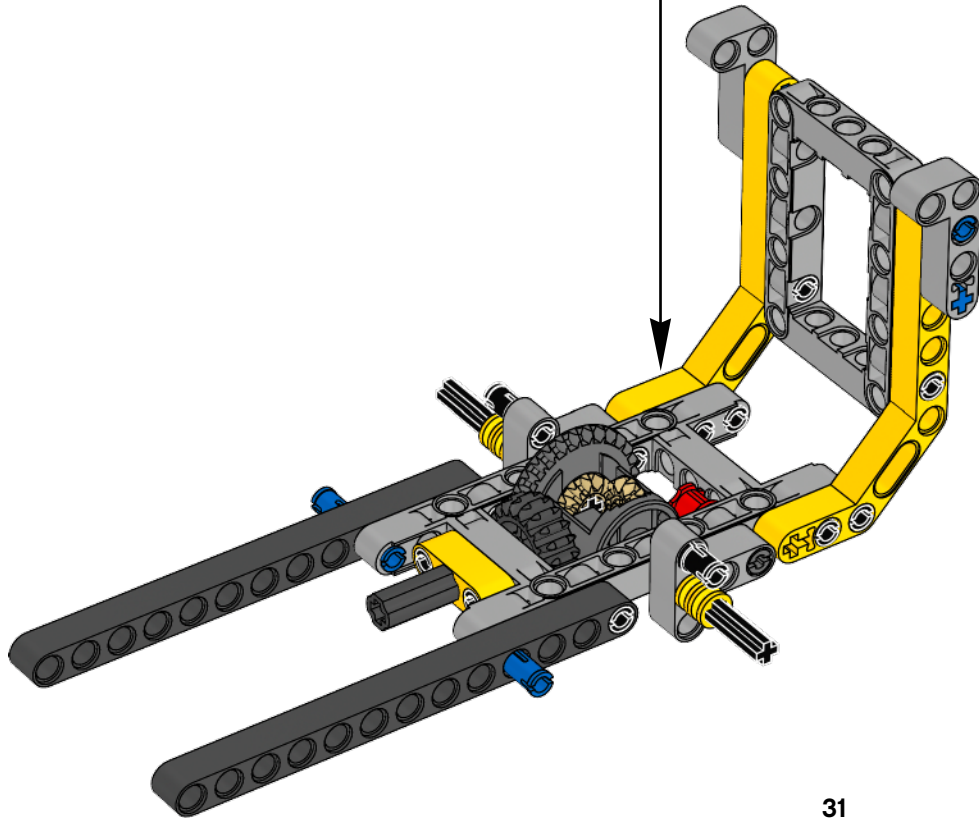
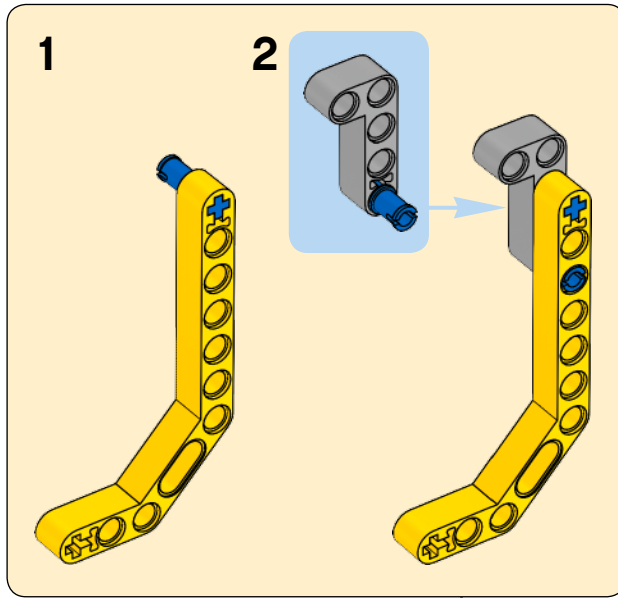

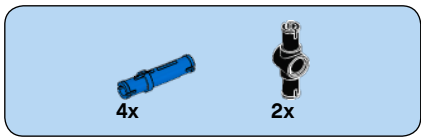

11

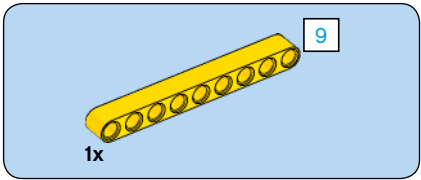
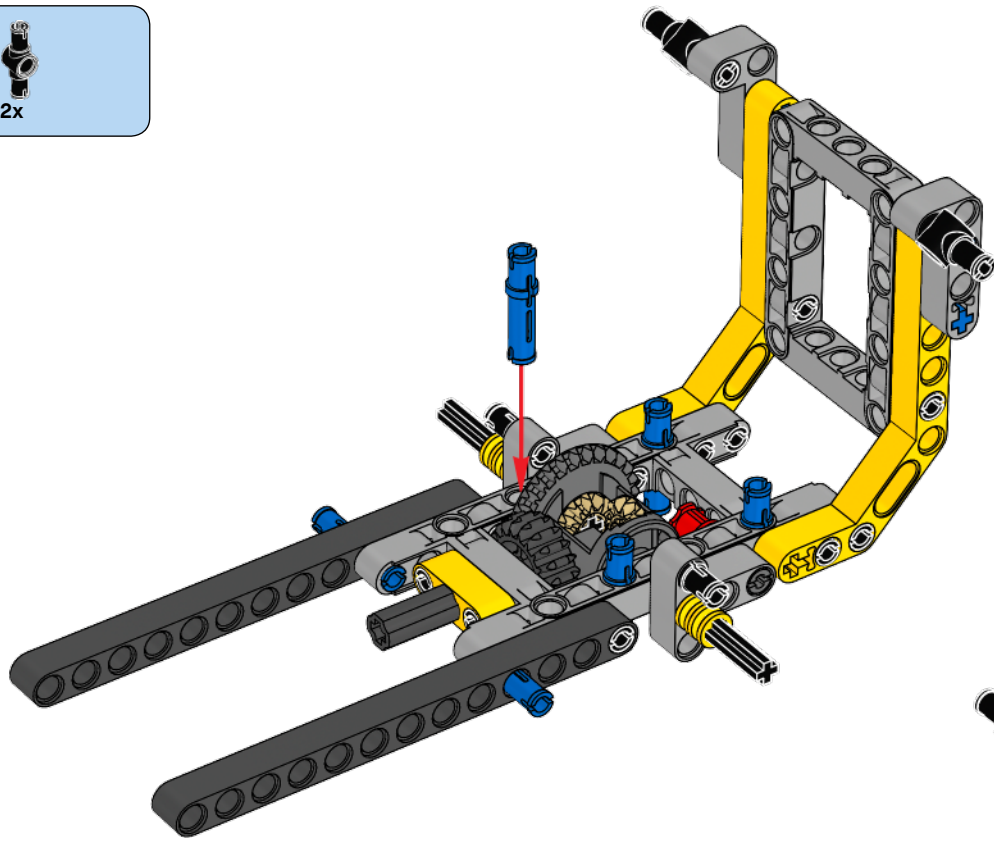

12

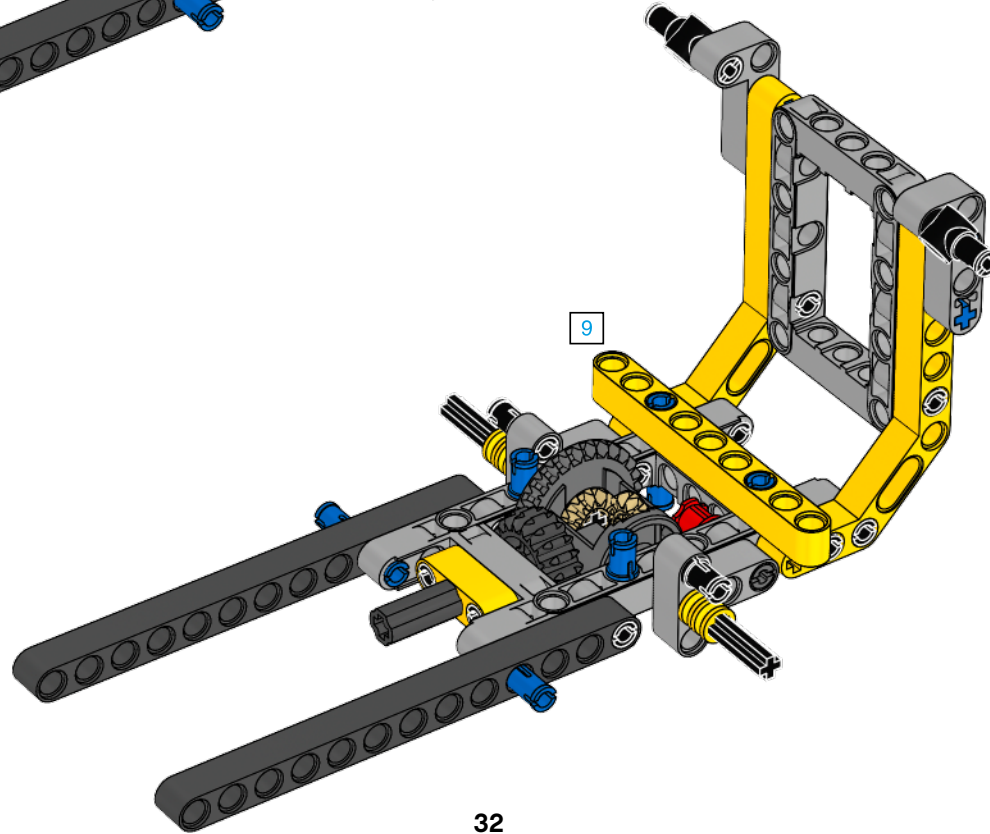

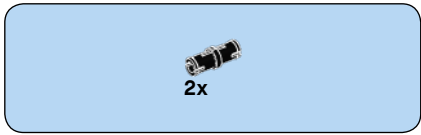

13

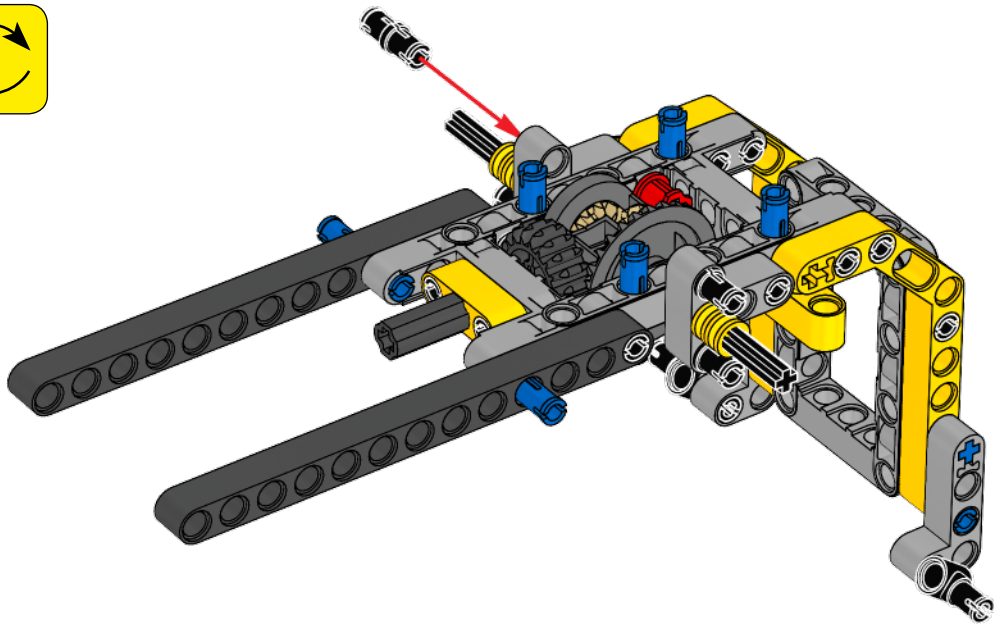
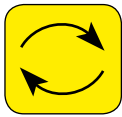

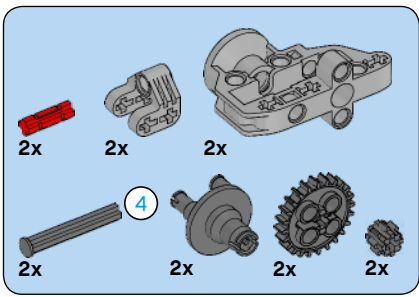

14

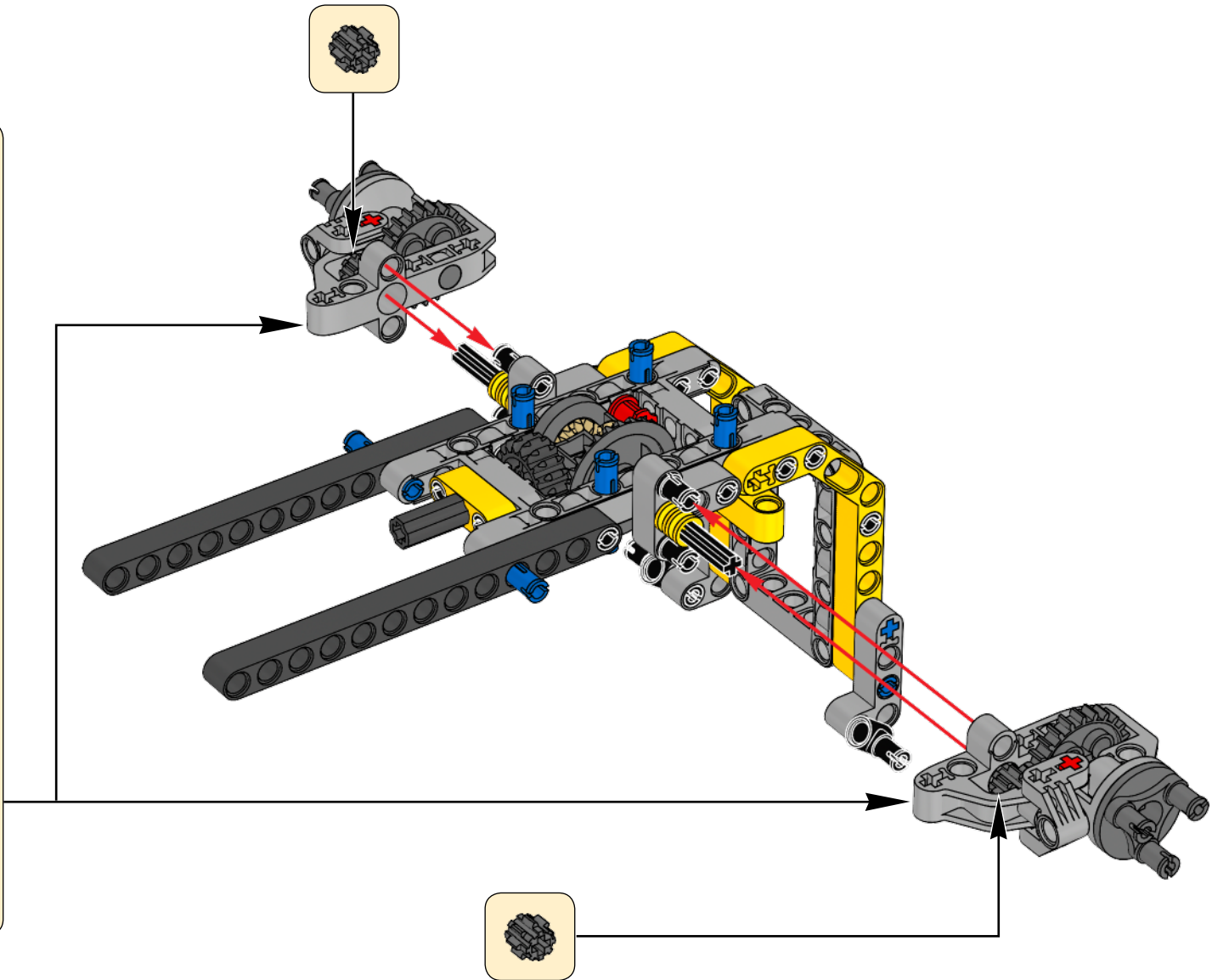
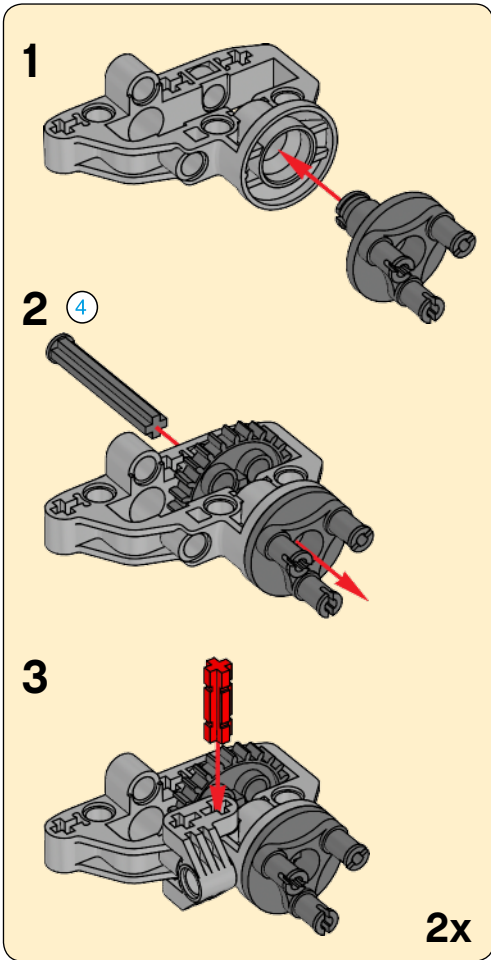

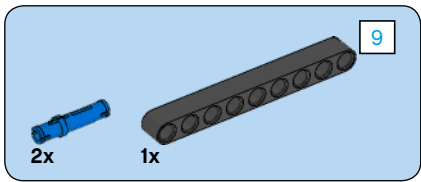

15

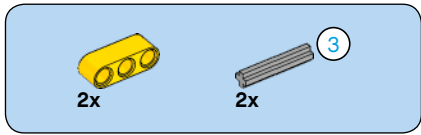
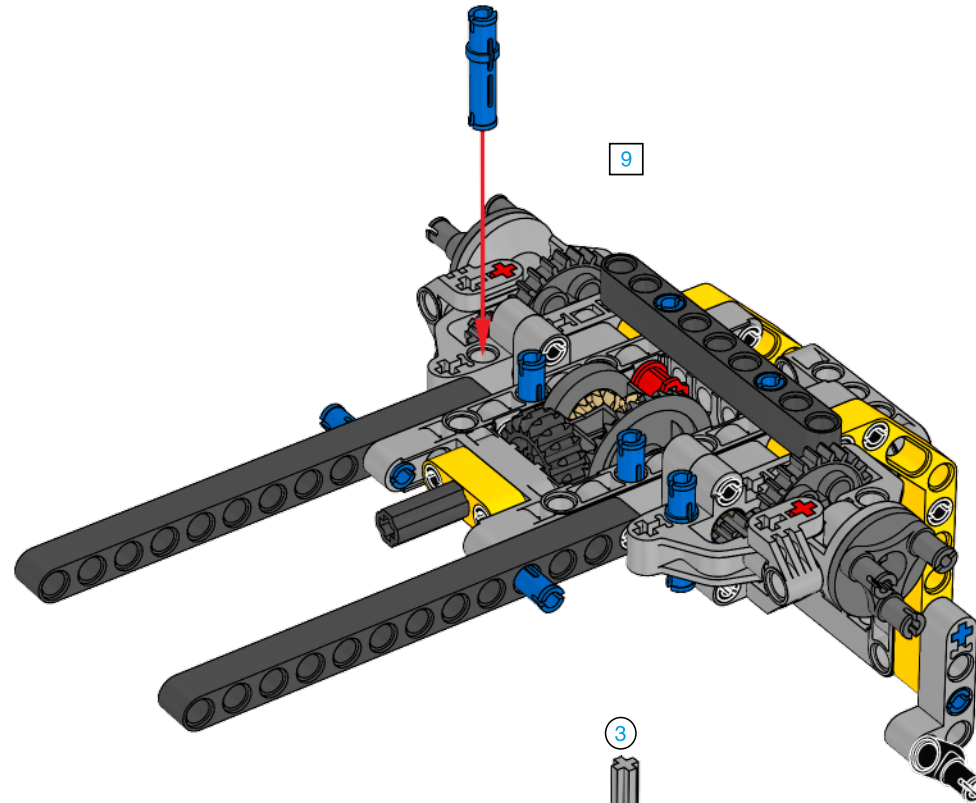

16

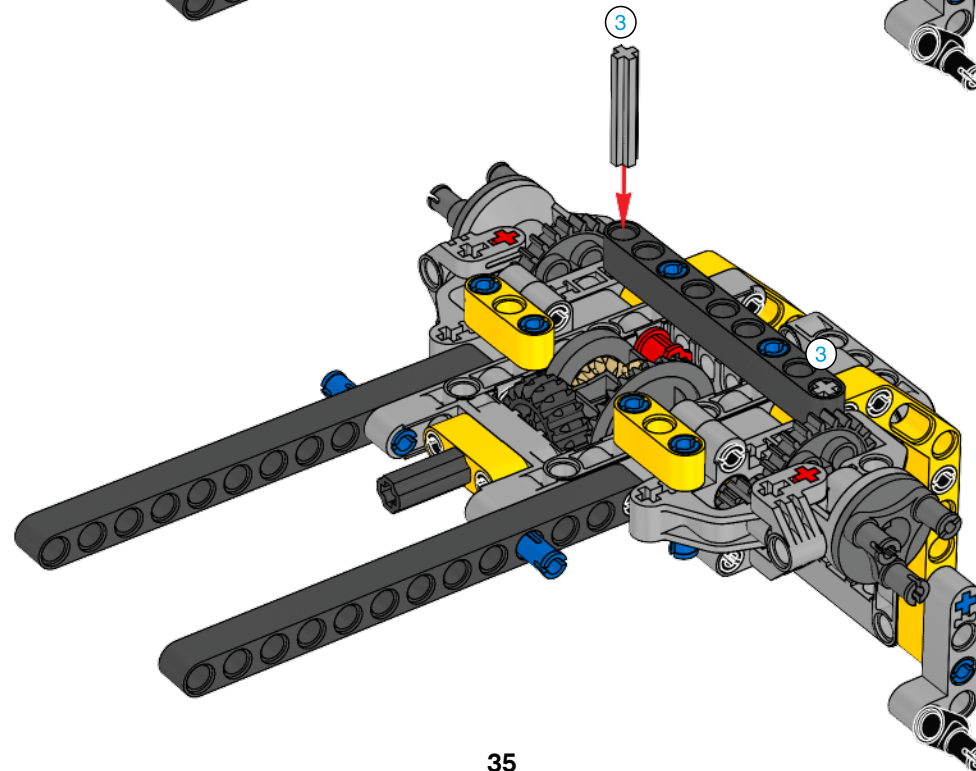

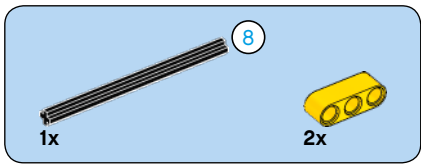

17

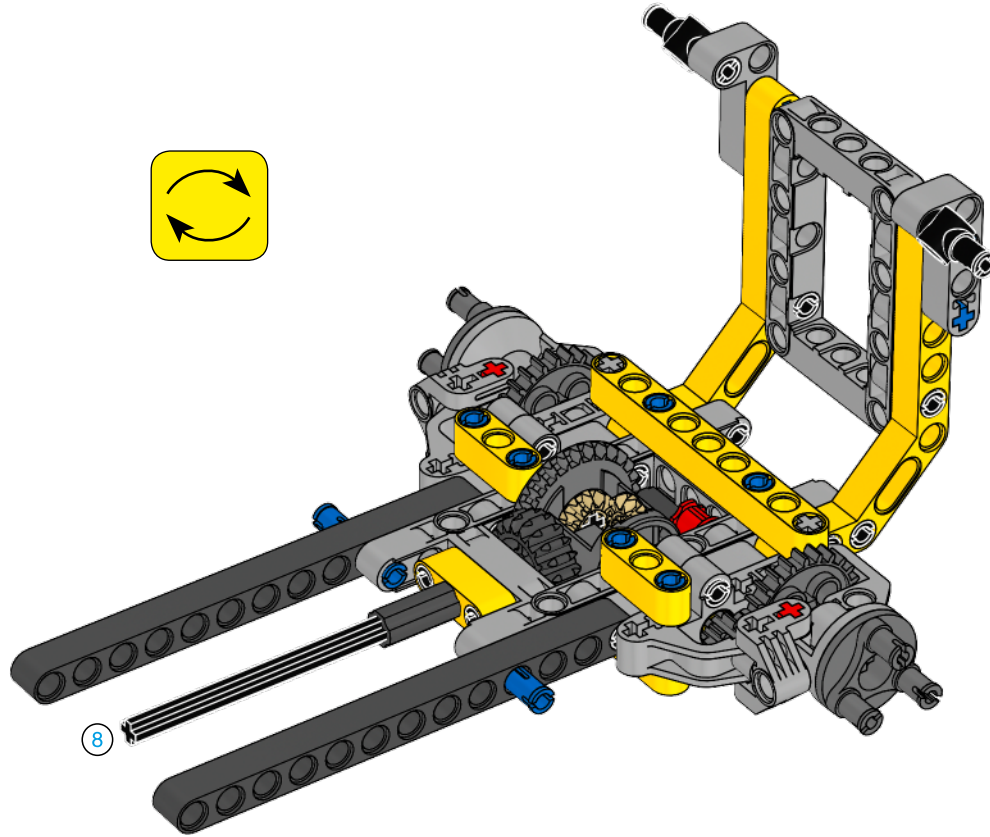

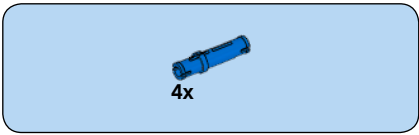

18

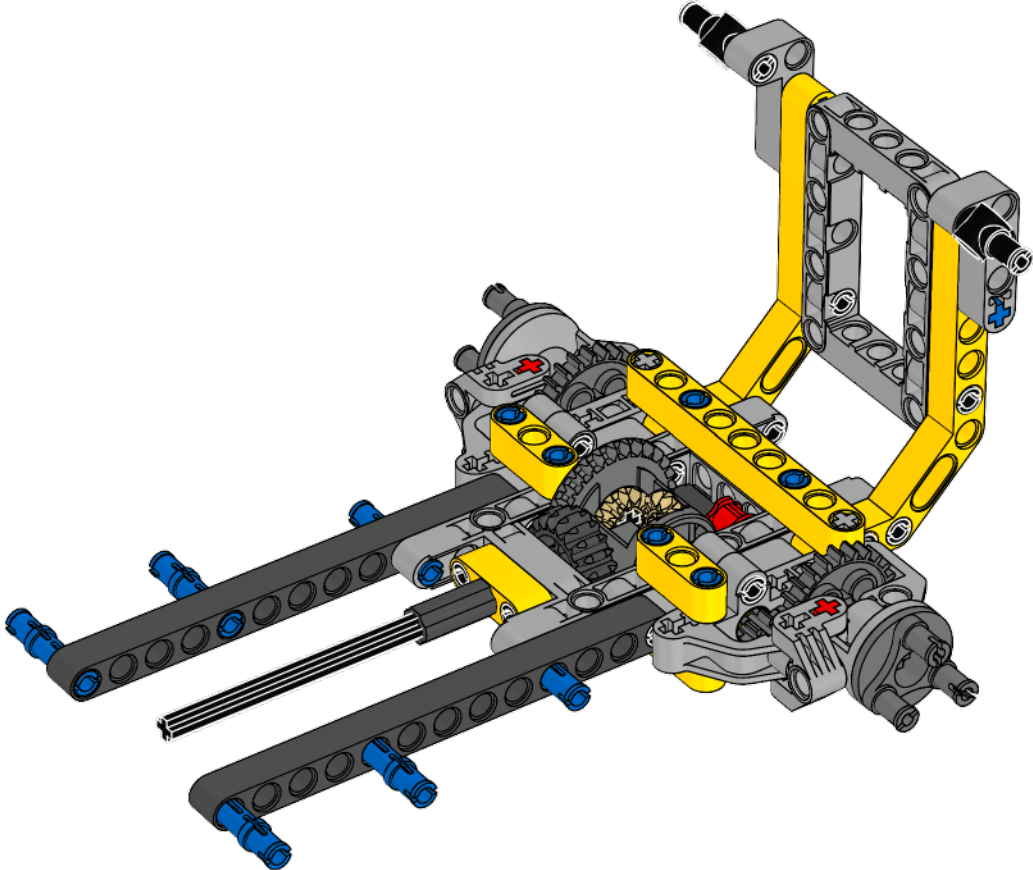

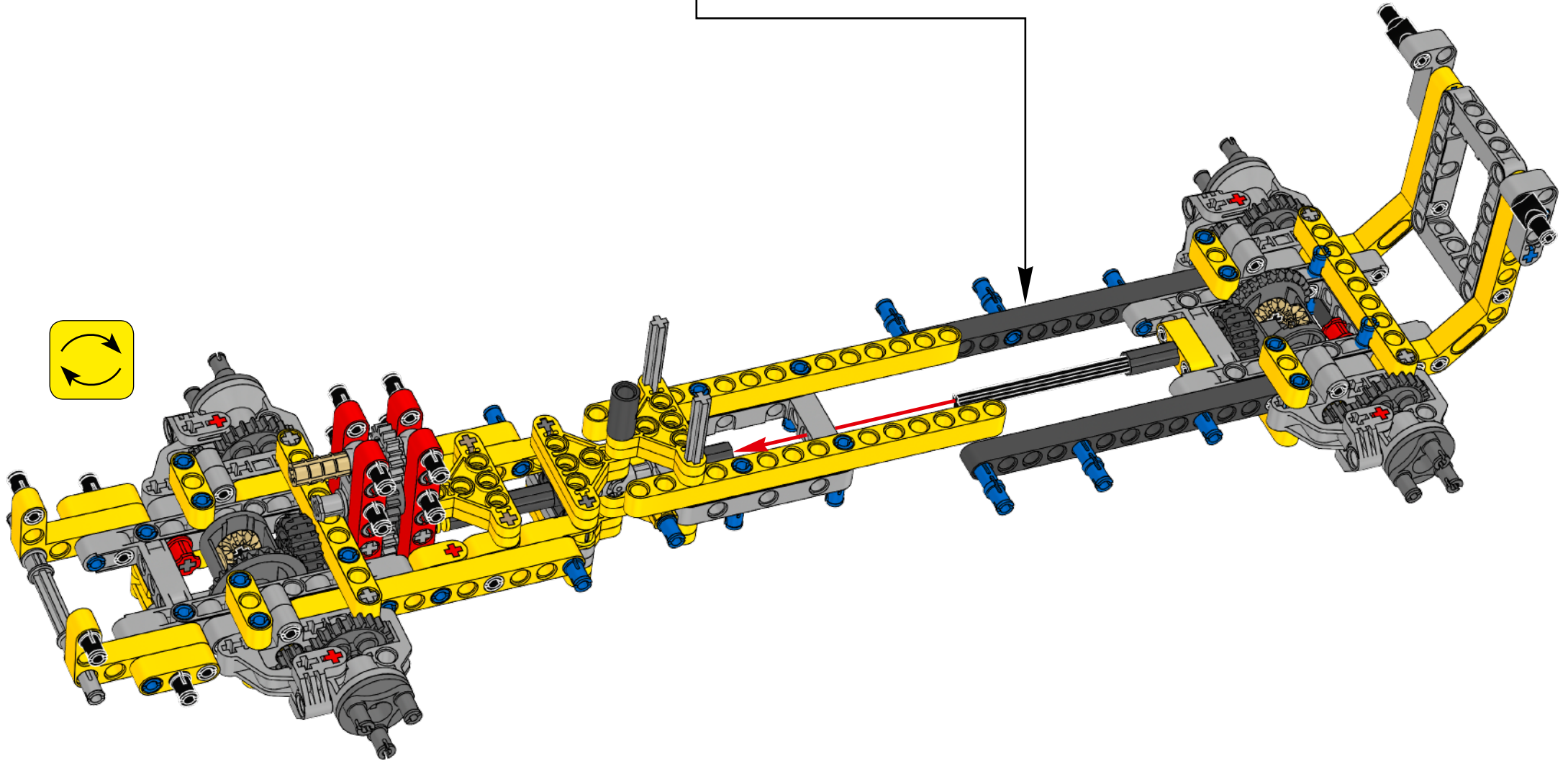

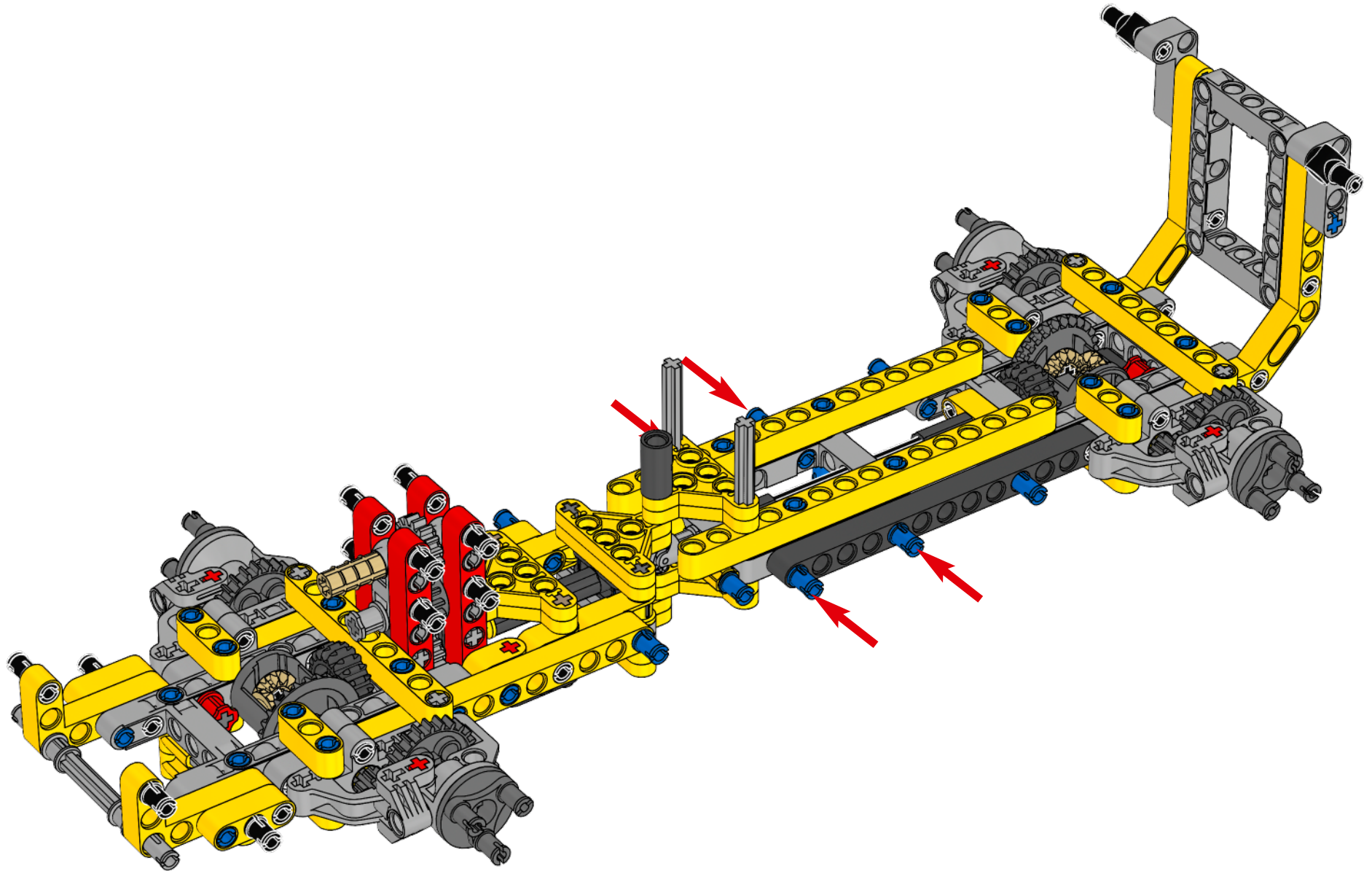

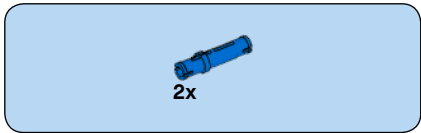

35

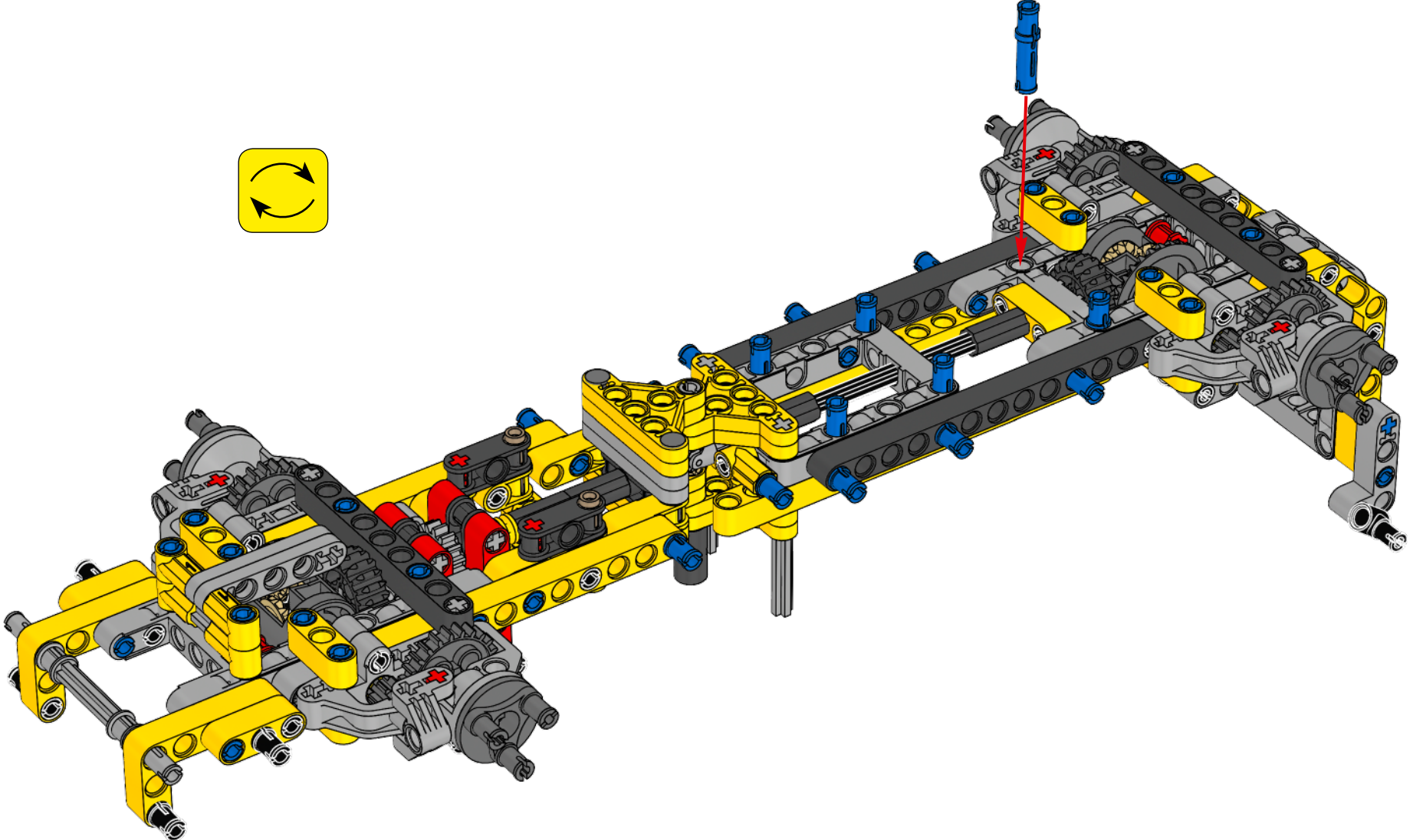

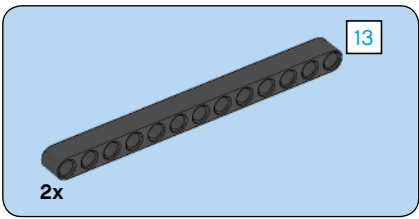

36

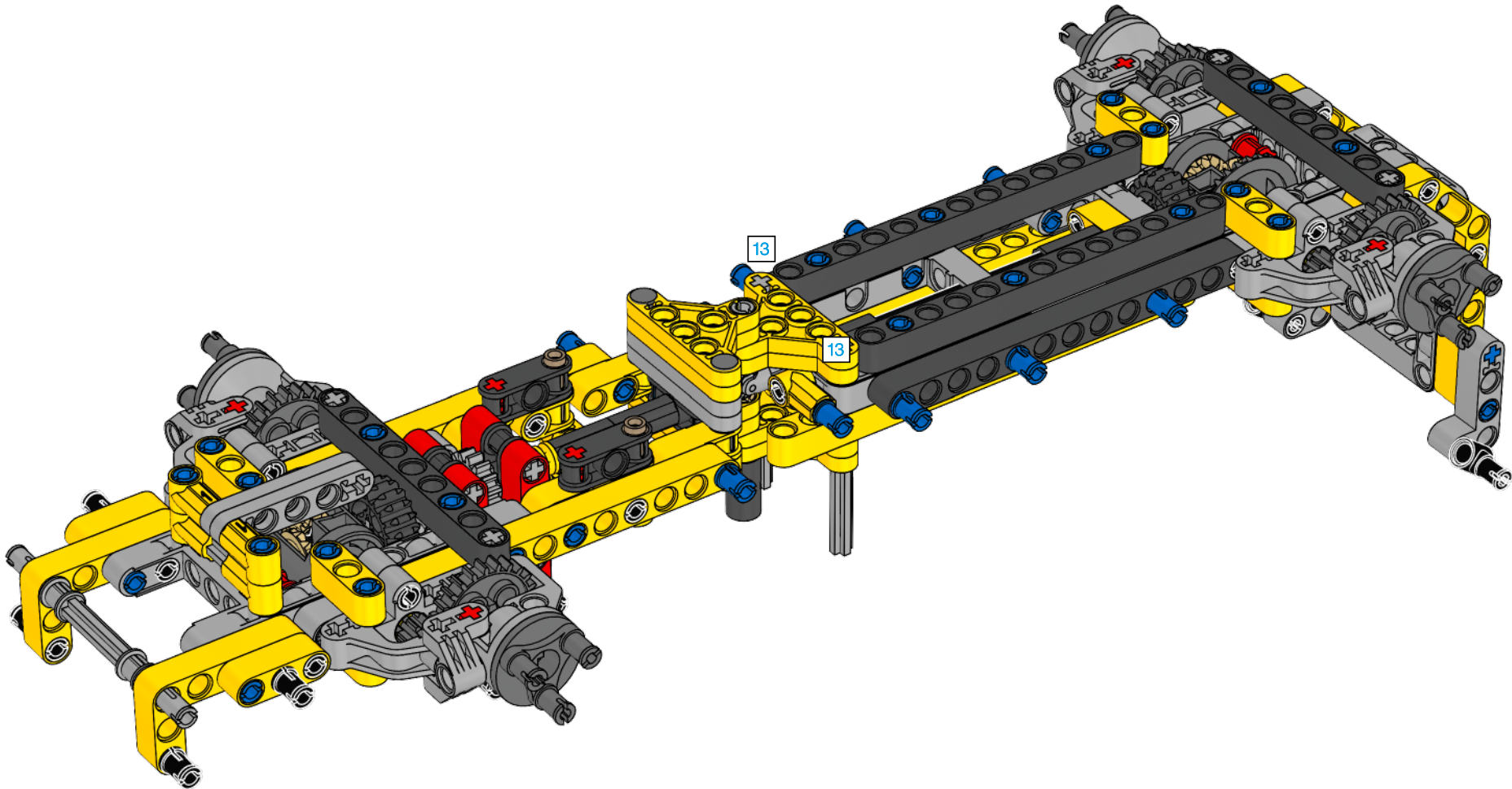

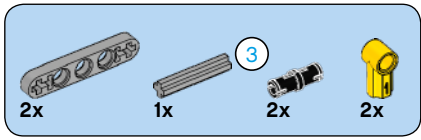

37

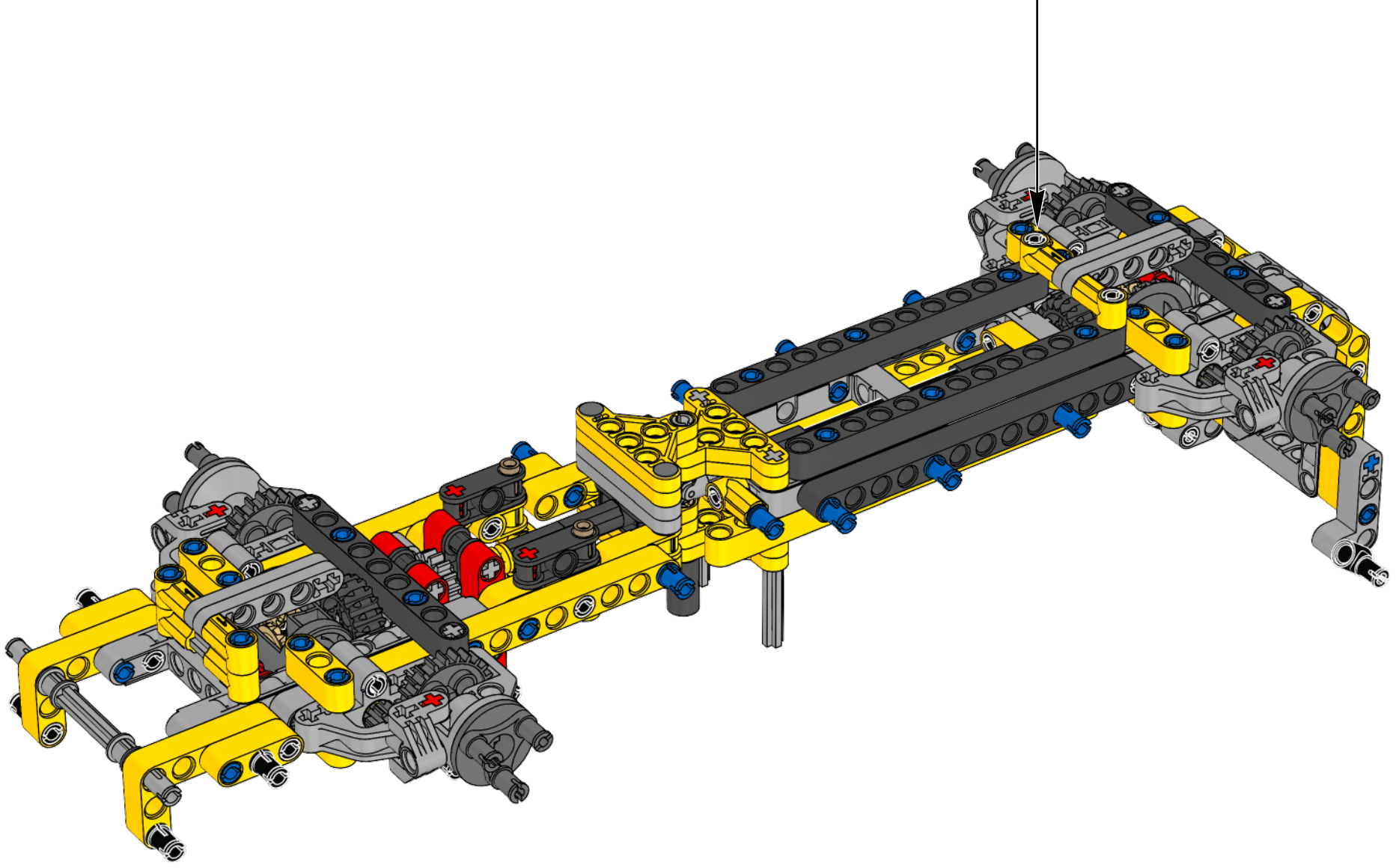
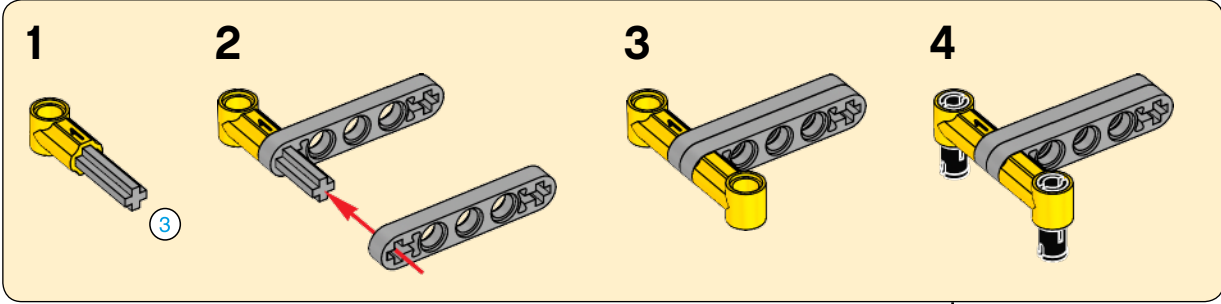

4x

38

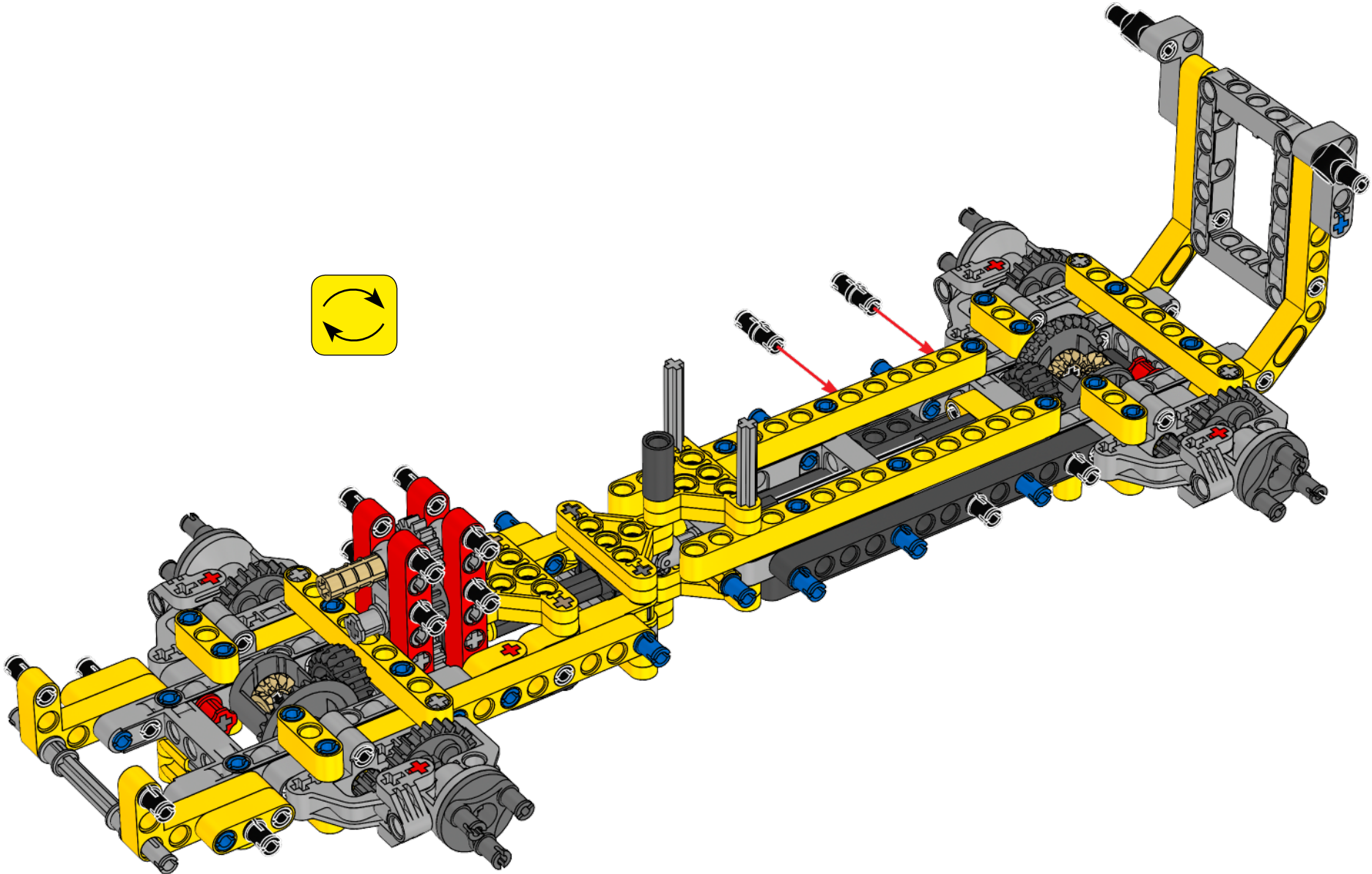
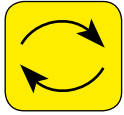

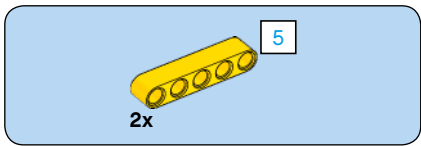

39

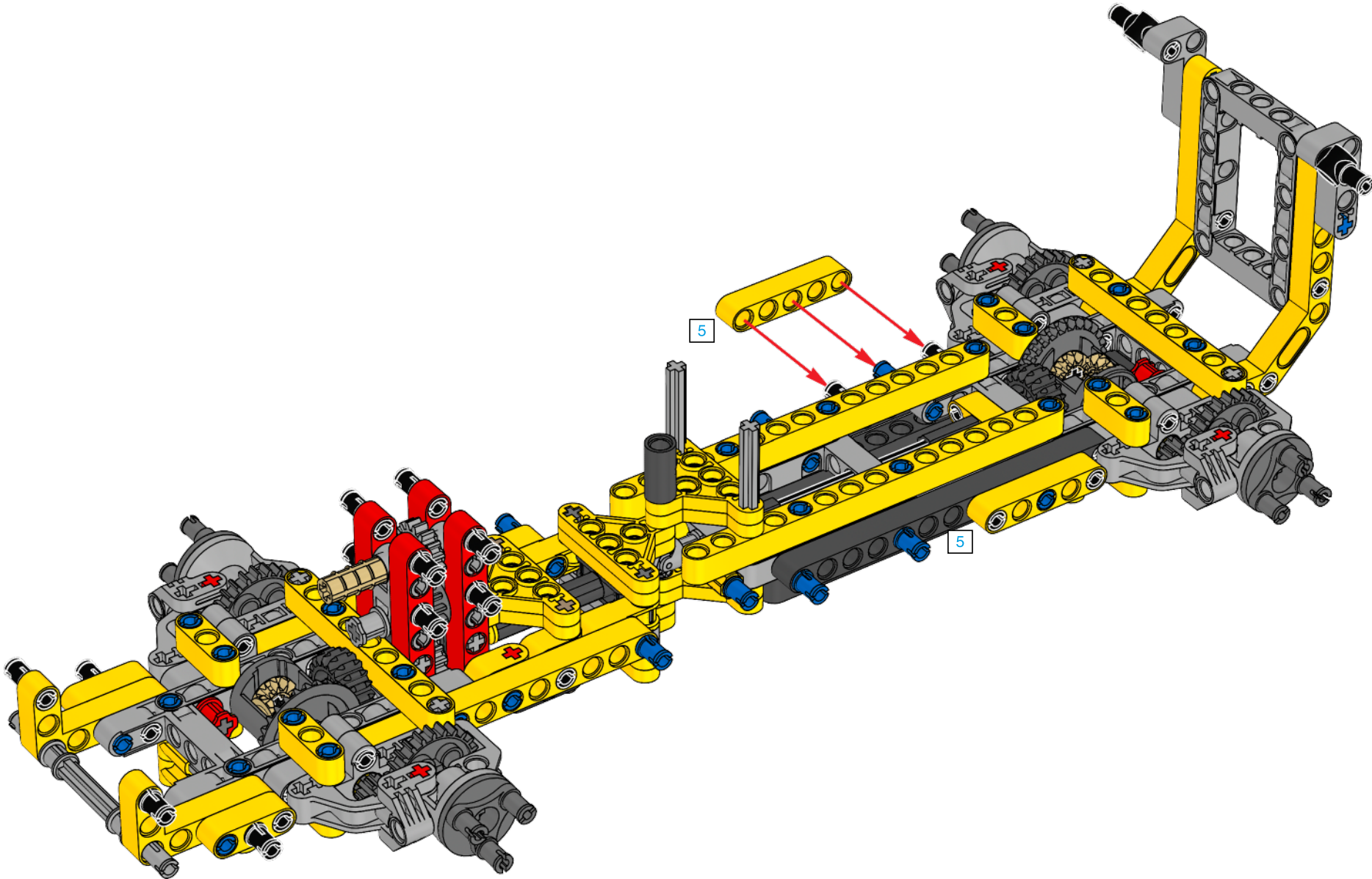

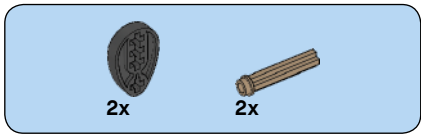
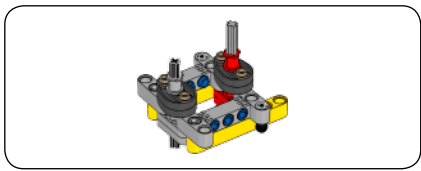

1

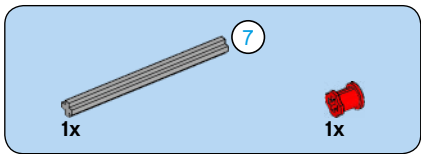
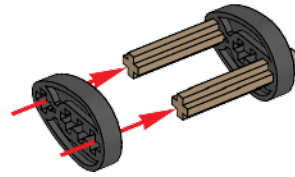

2

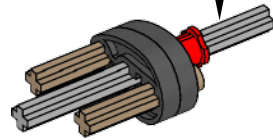
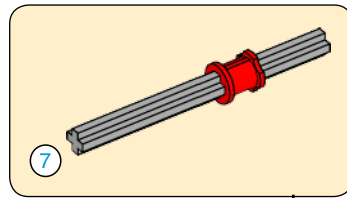

3

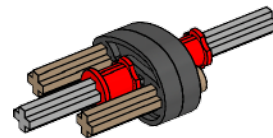

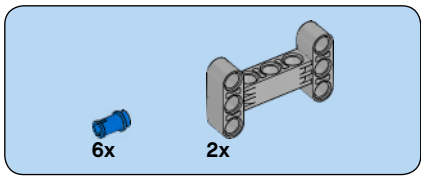

4

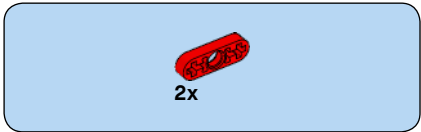
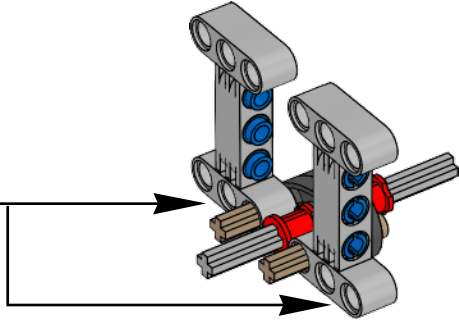
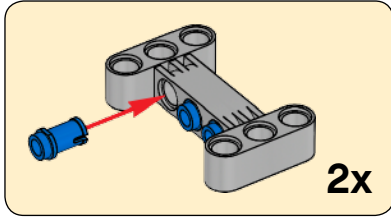

5

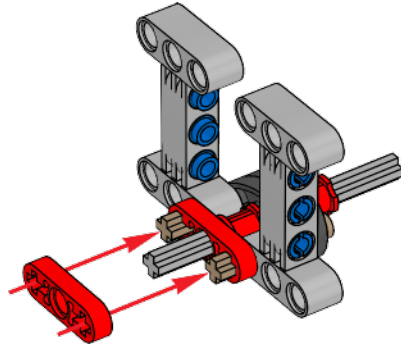

6

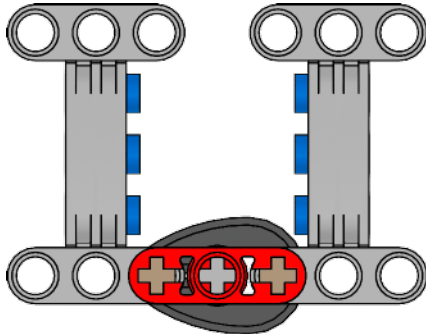

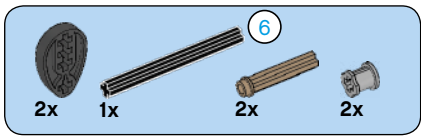

7

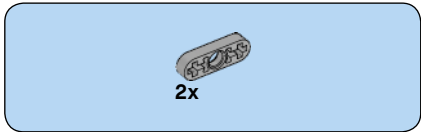
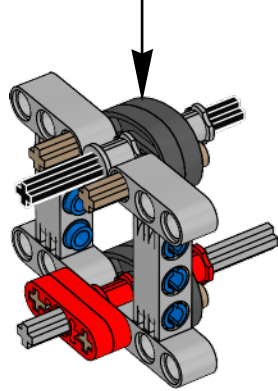
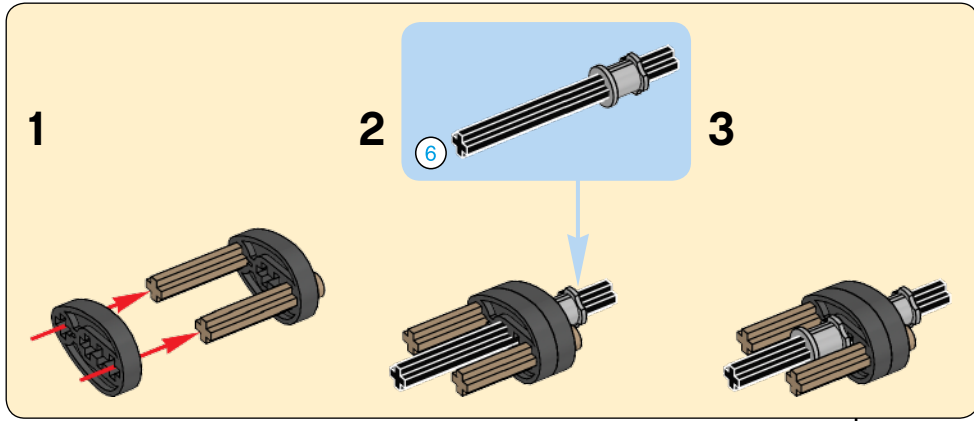

8

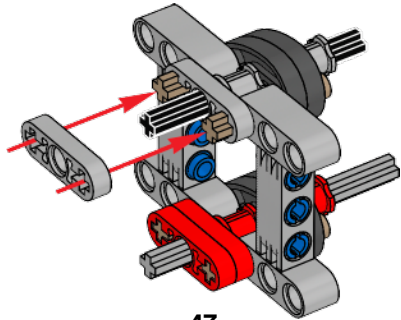

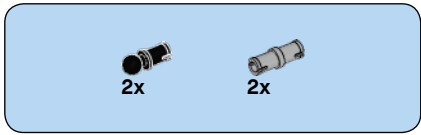

9

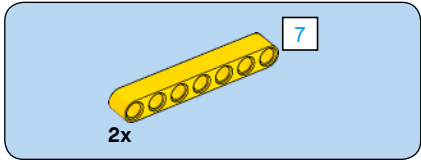
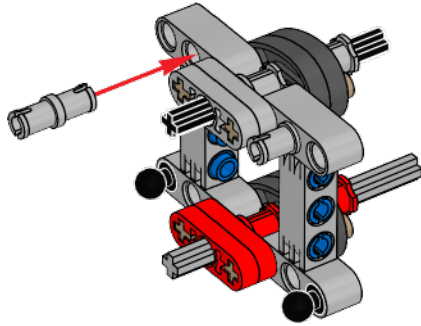

10

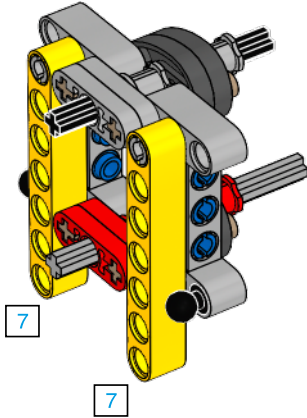

11

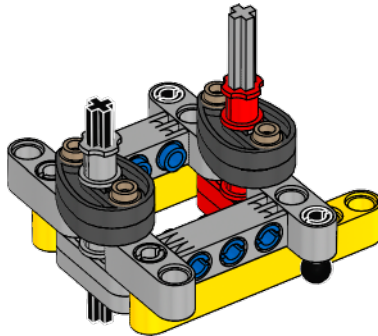

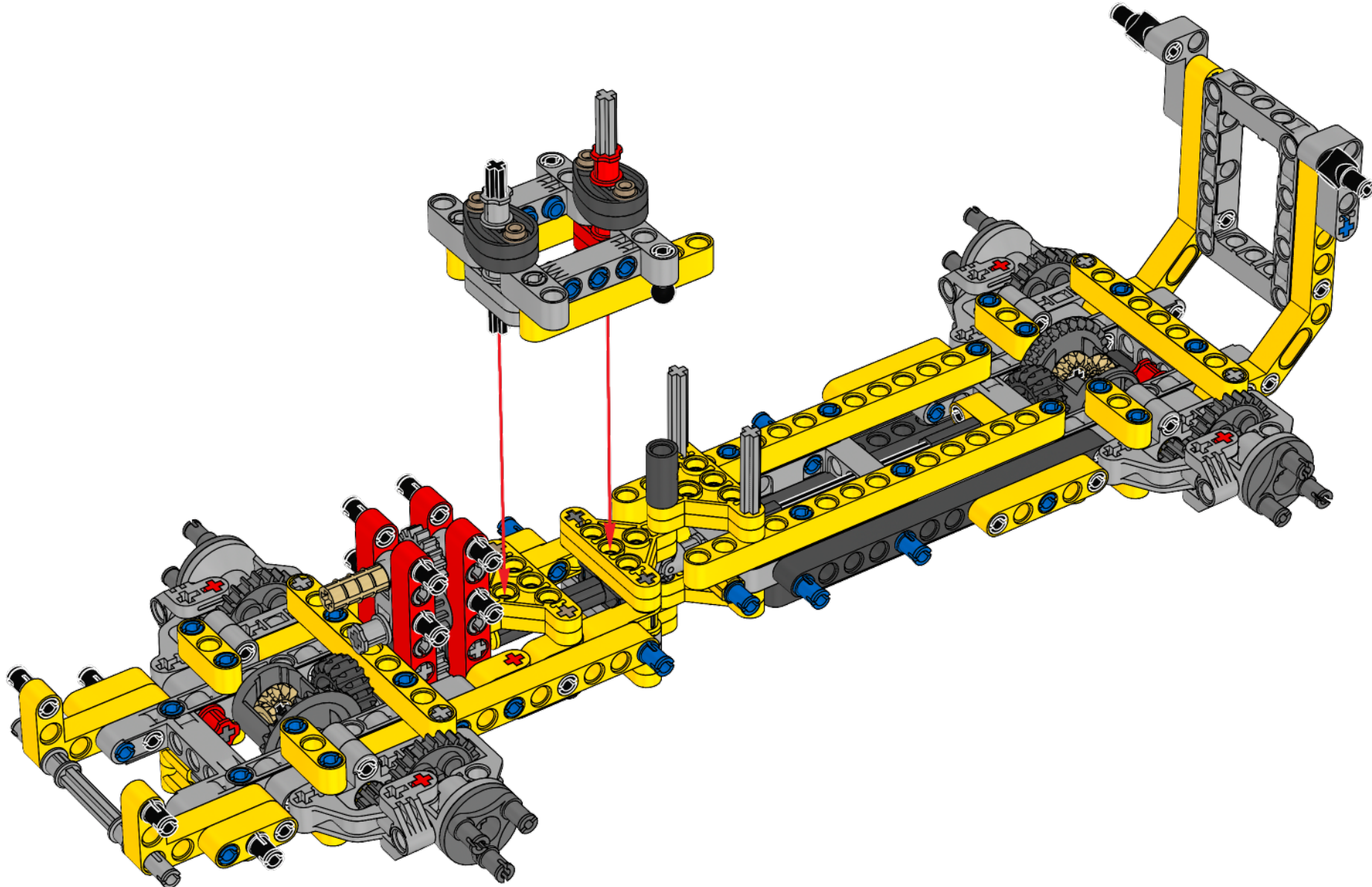

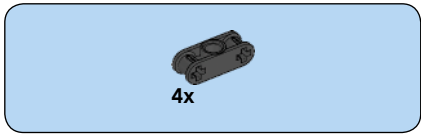

41

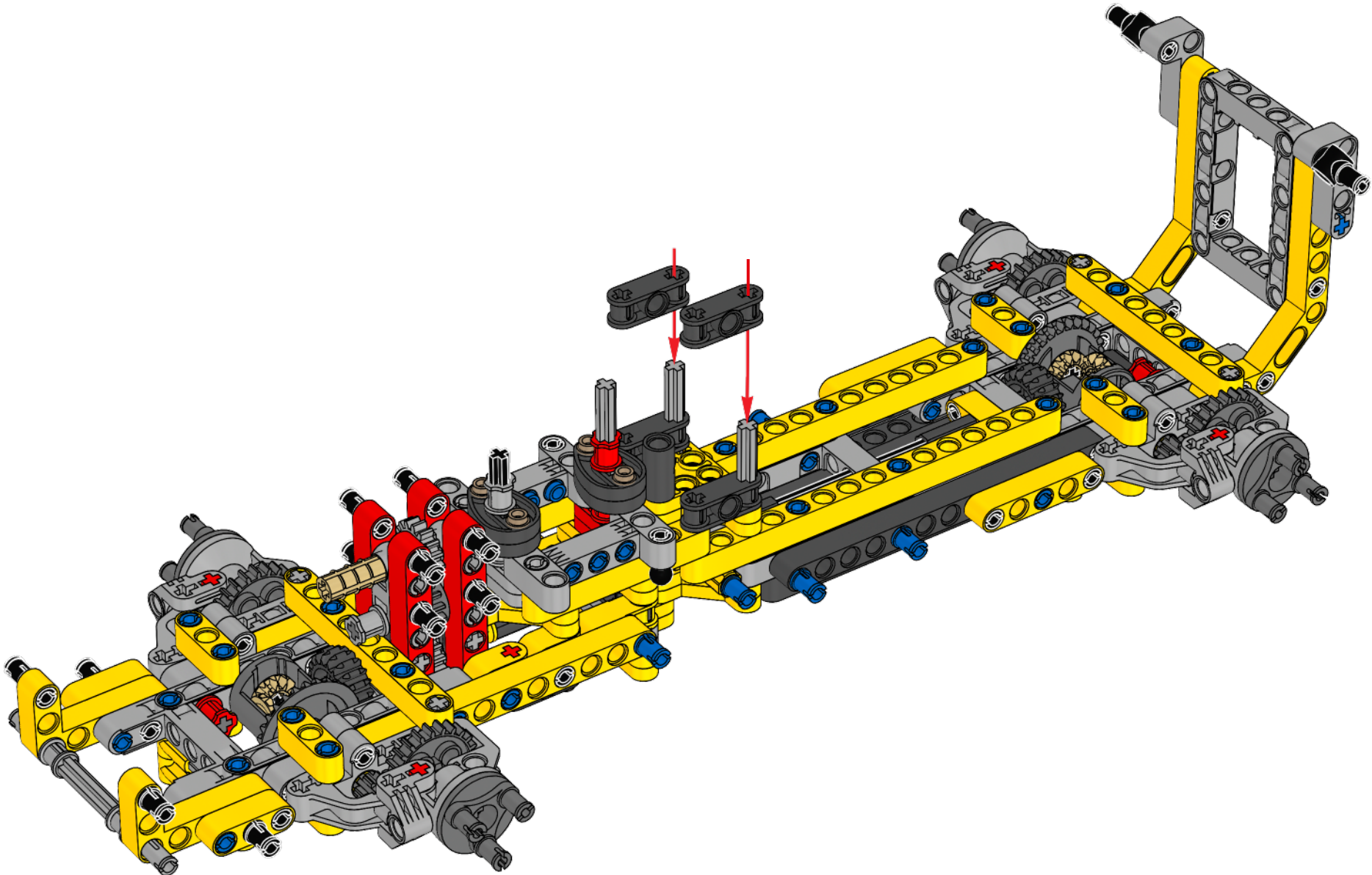

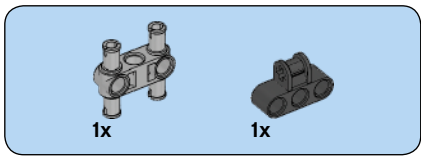

42

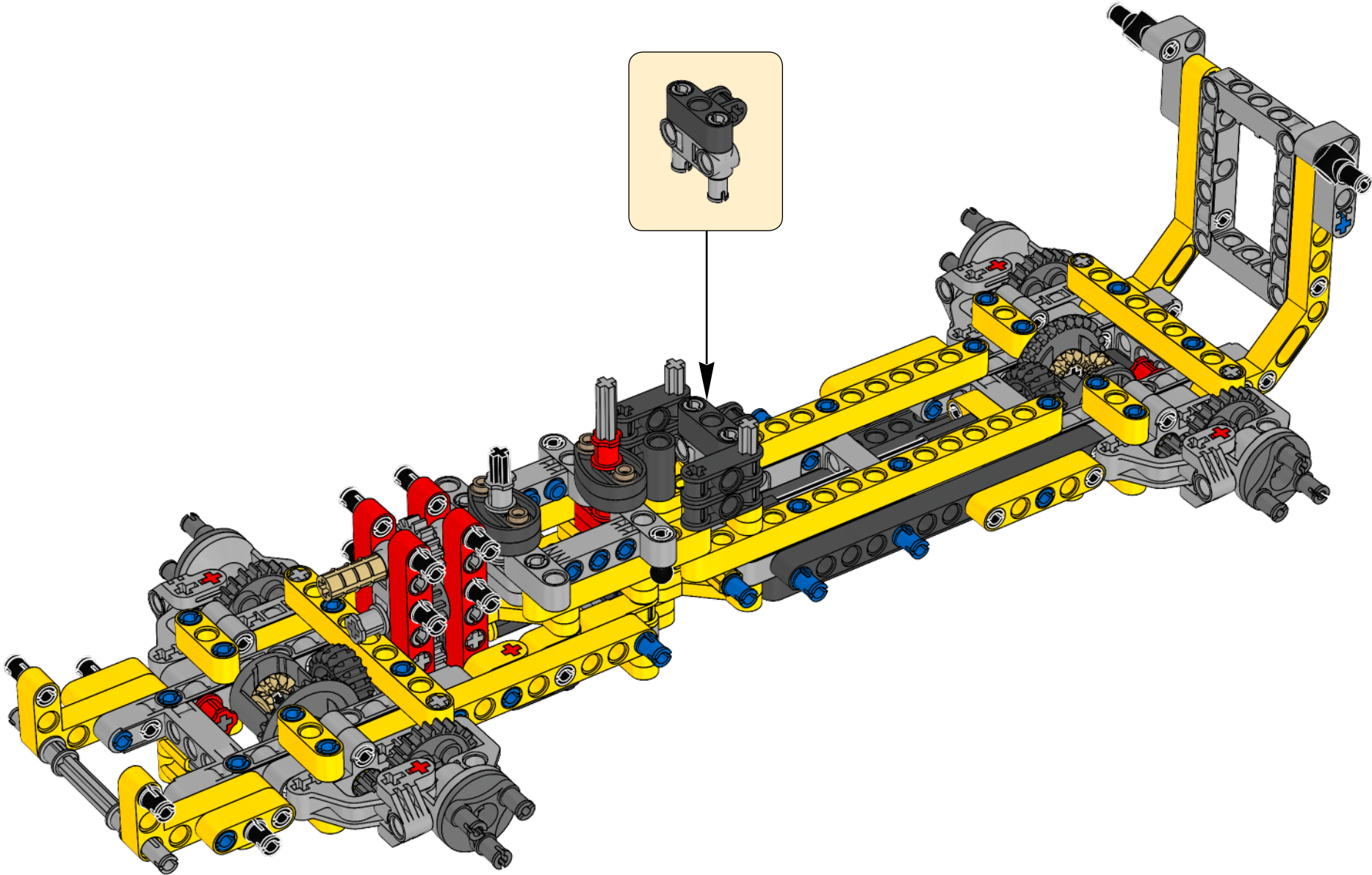

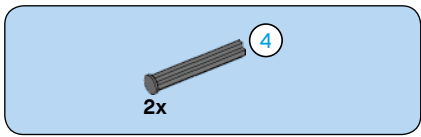

43

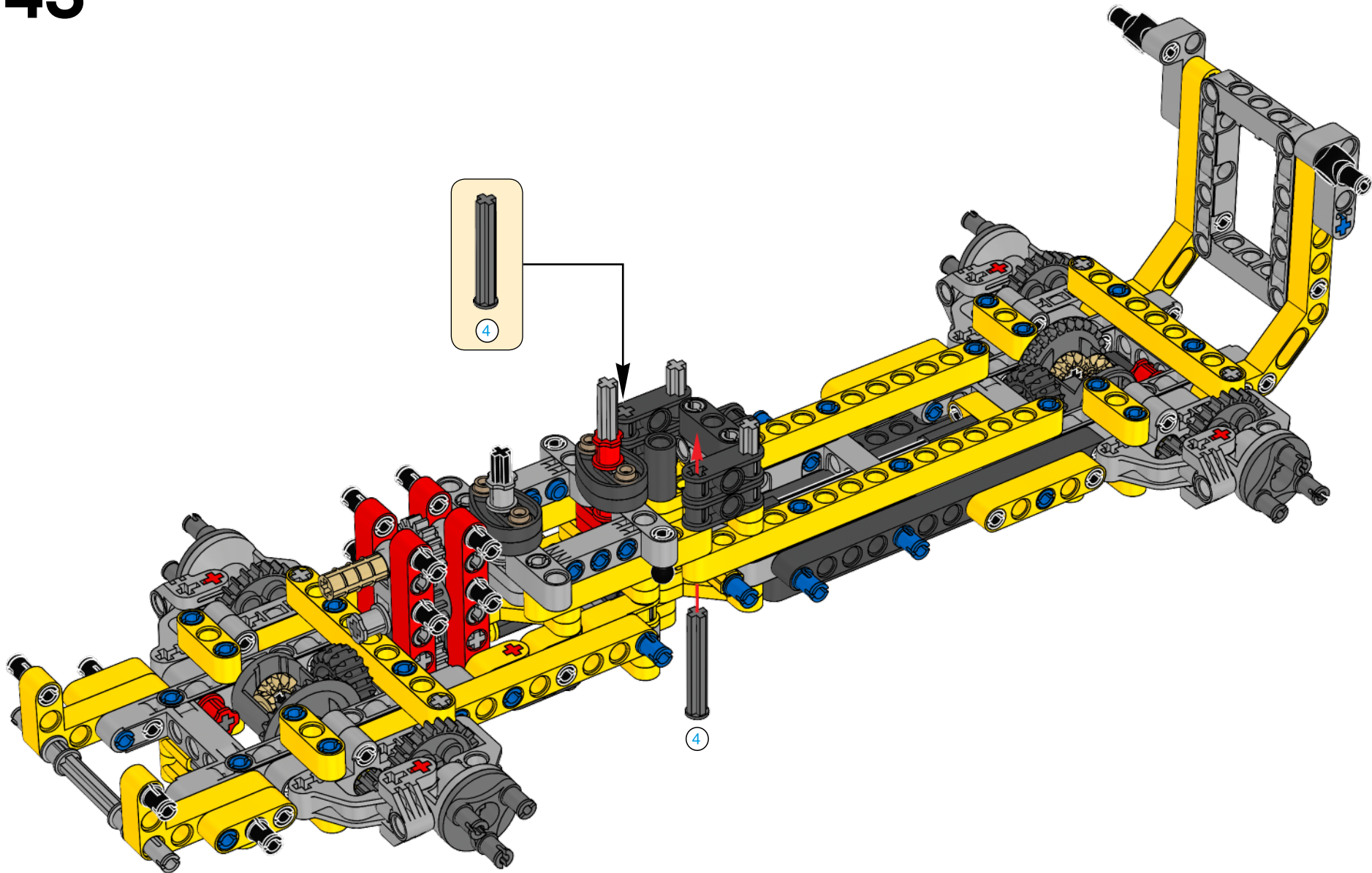

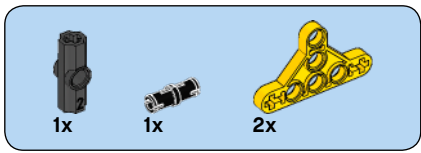

44

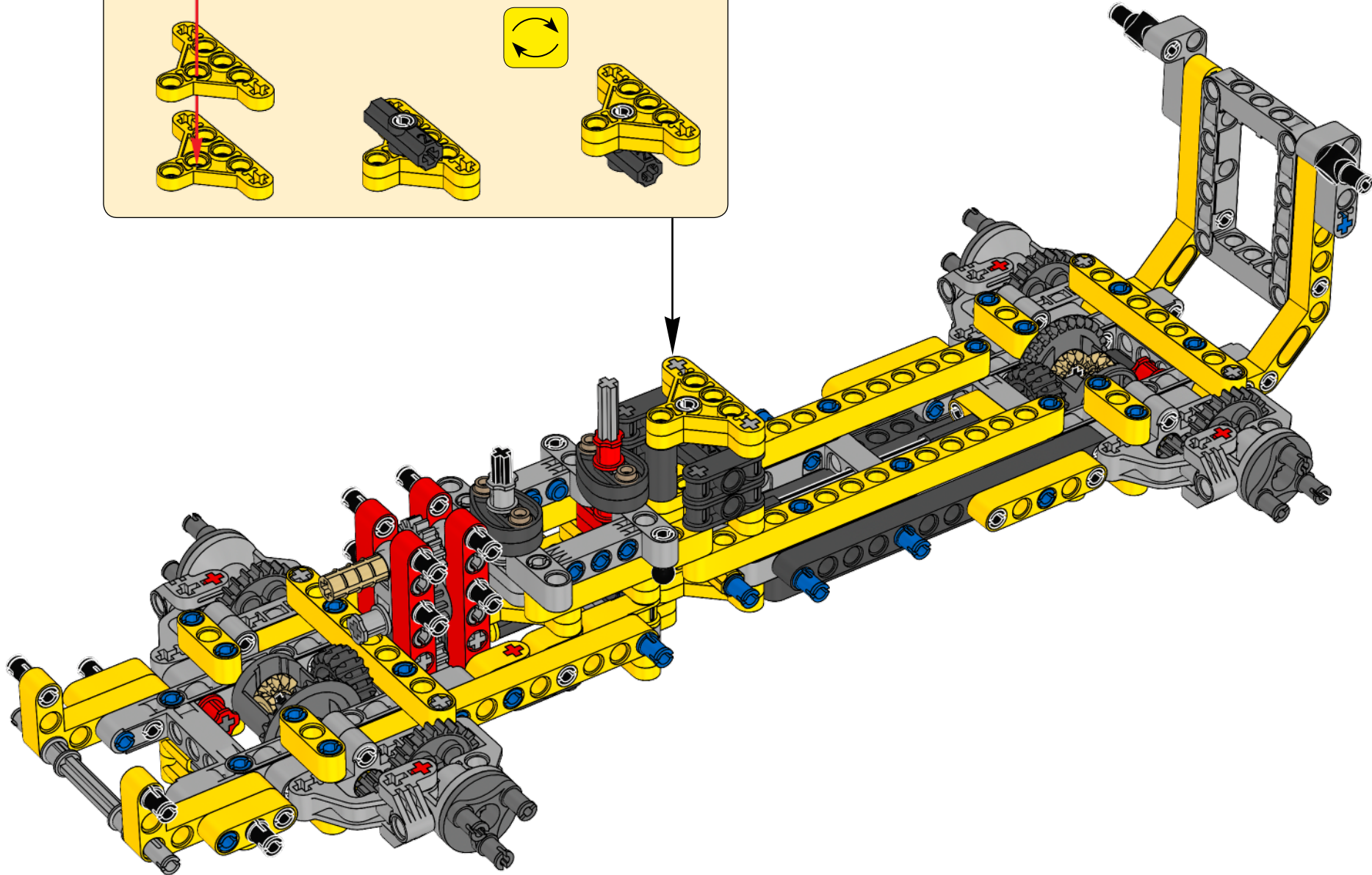
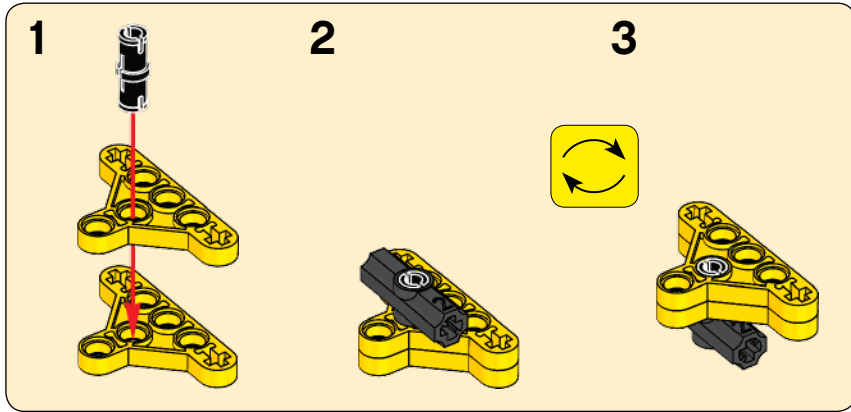

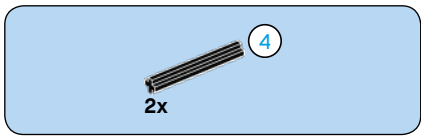

45

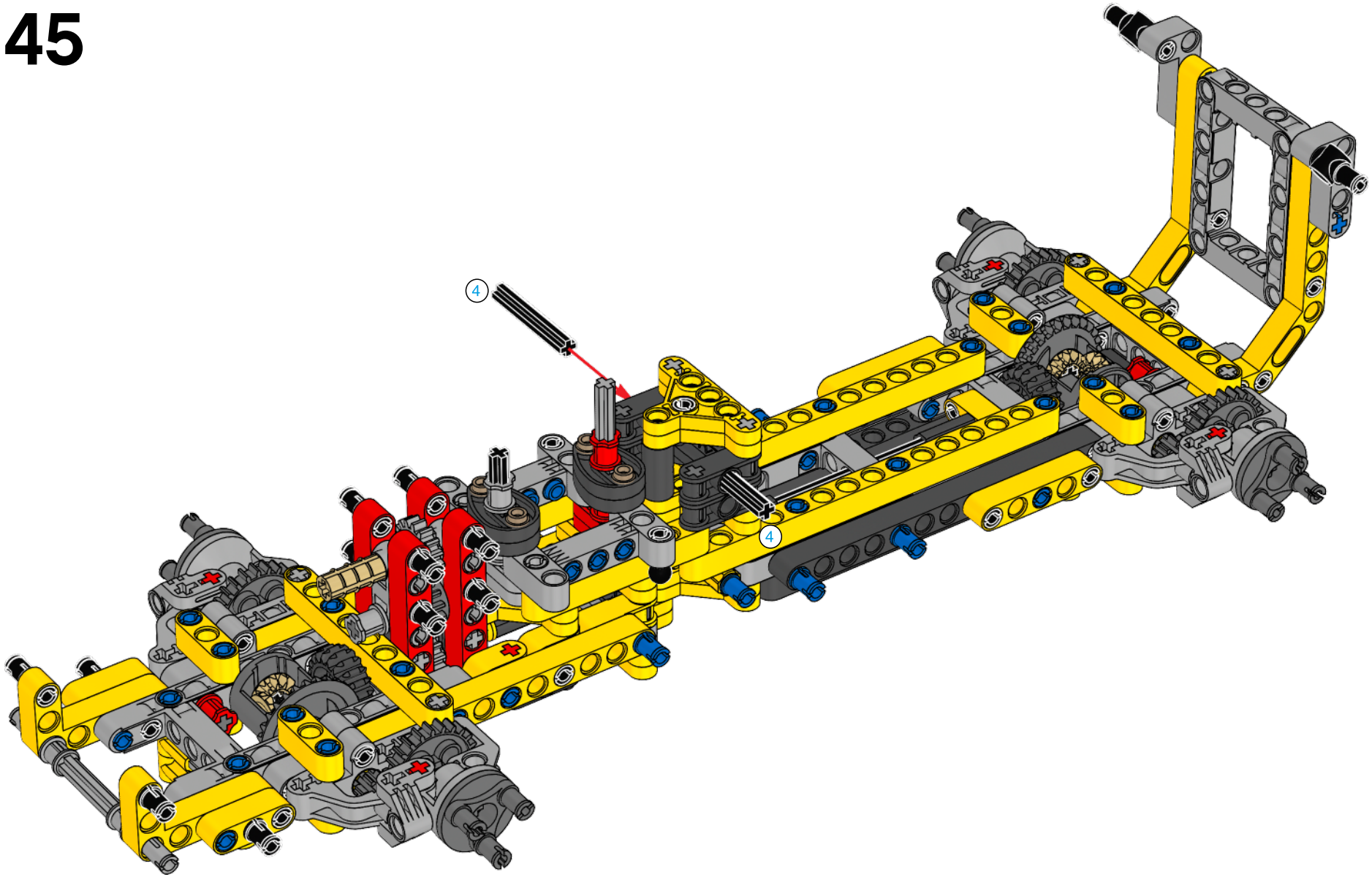

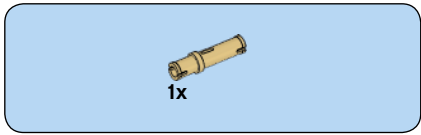

46

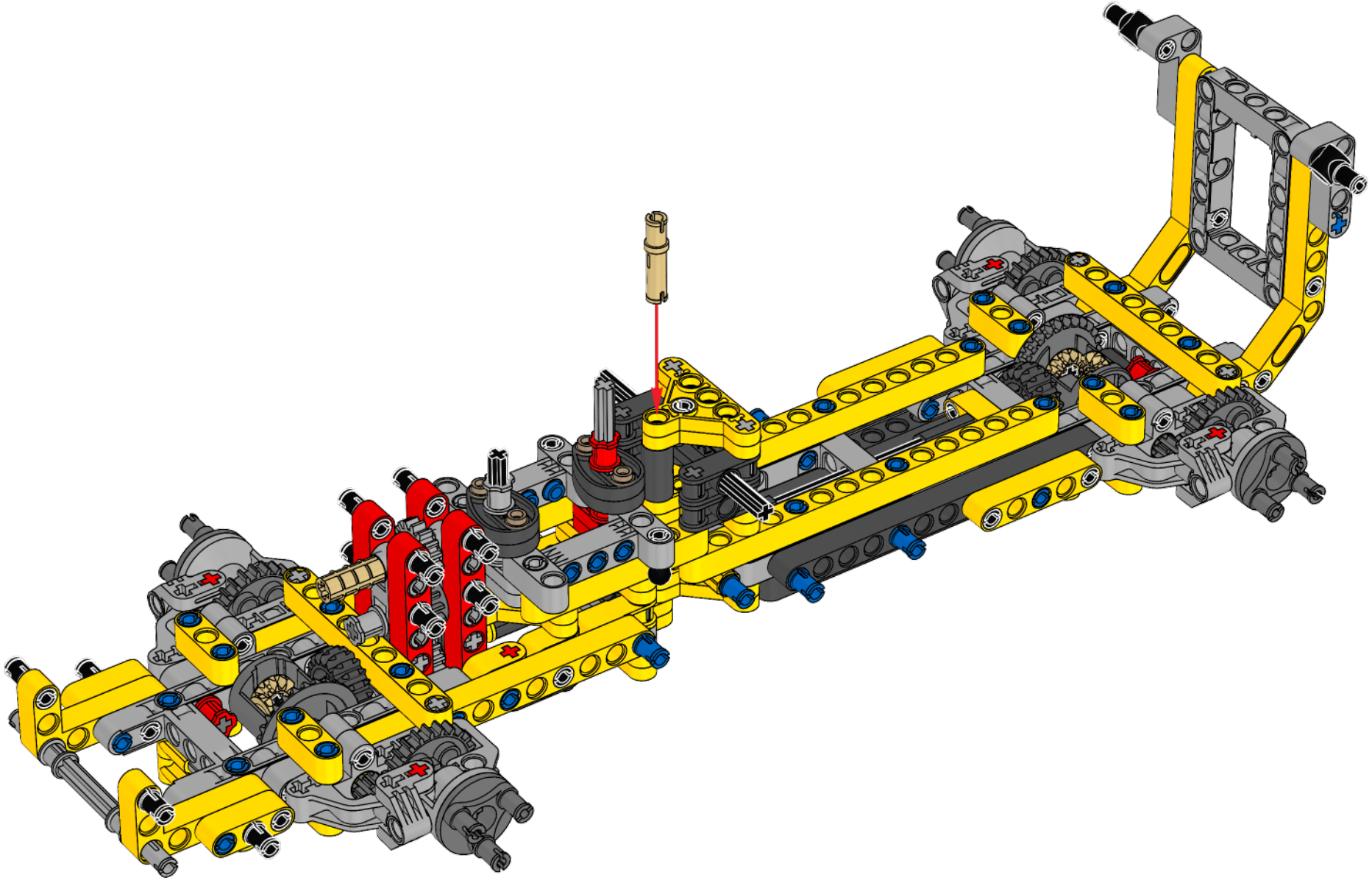

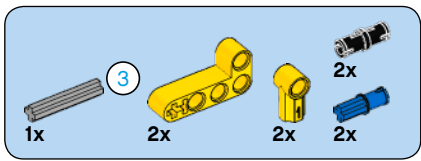

47

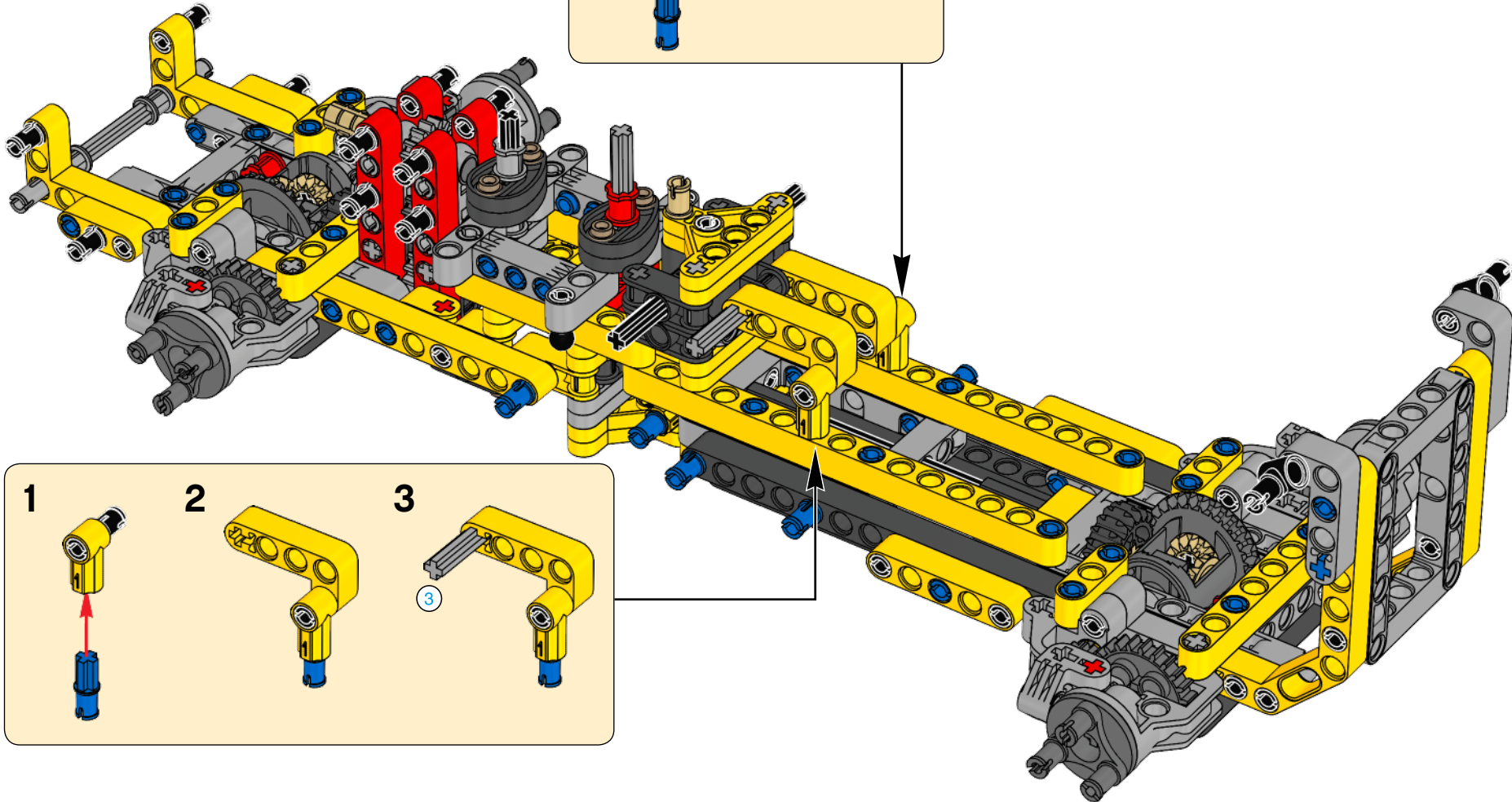
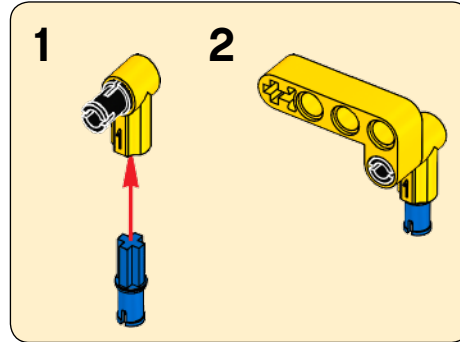

48

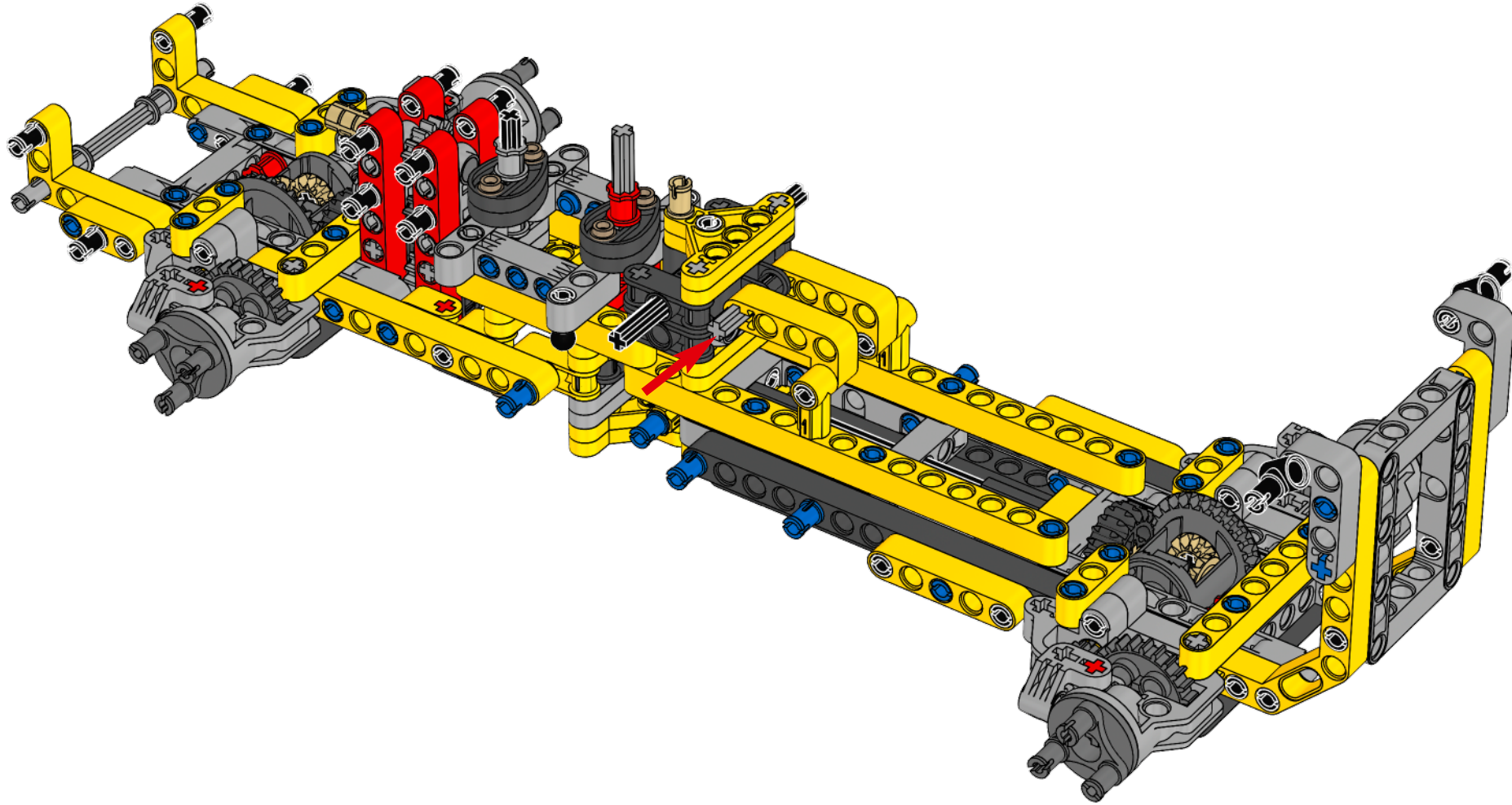

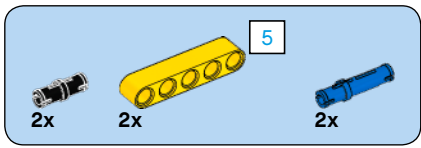

49

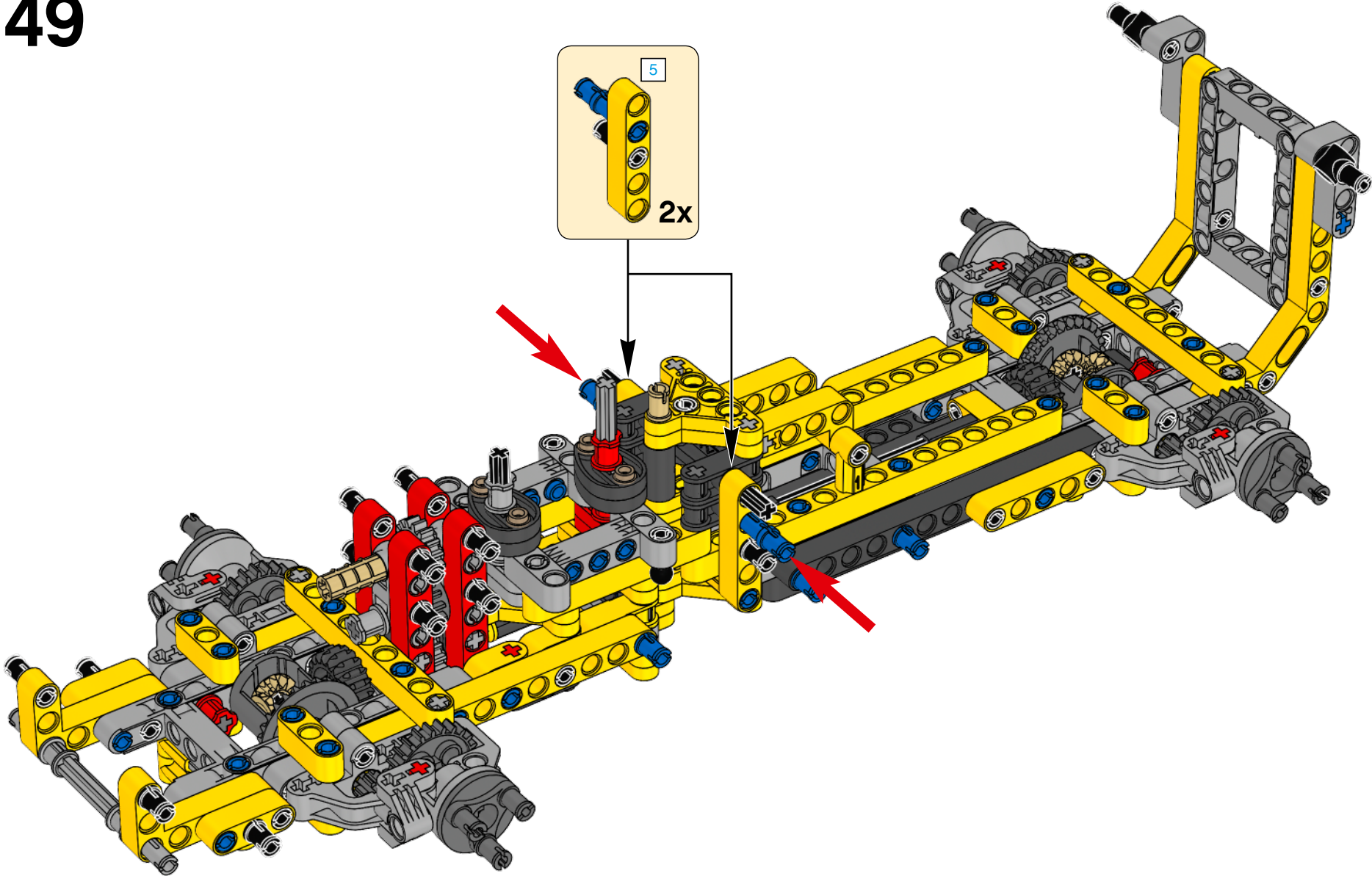

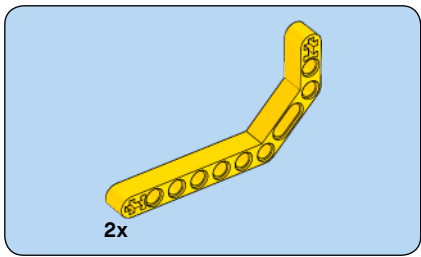

50

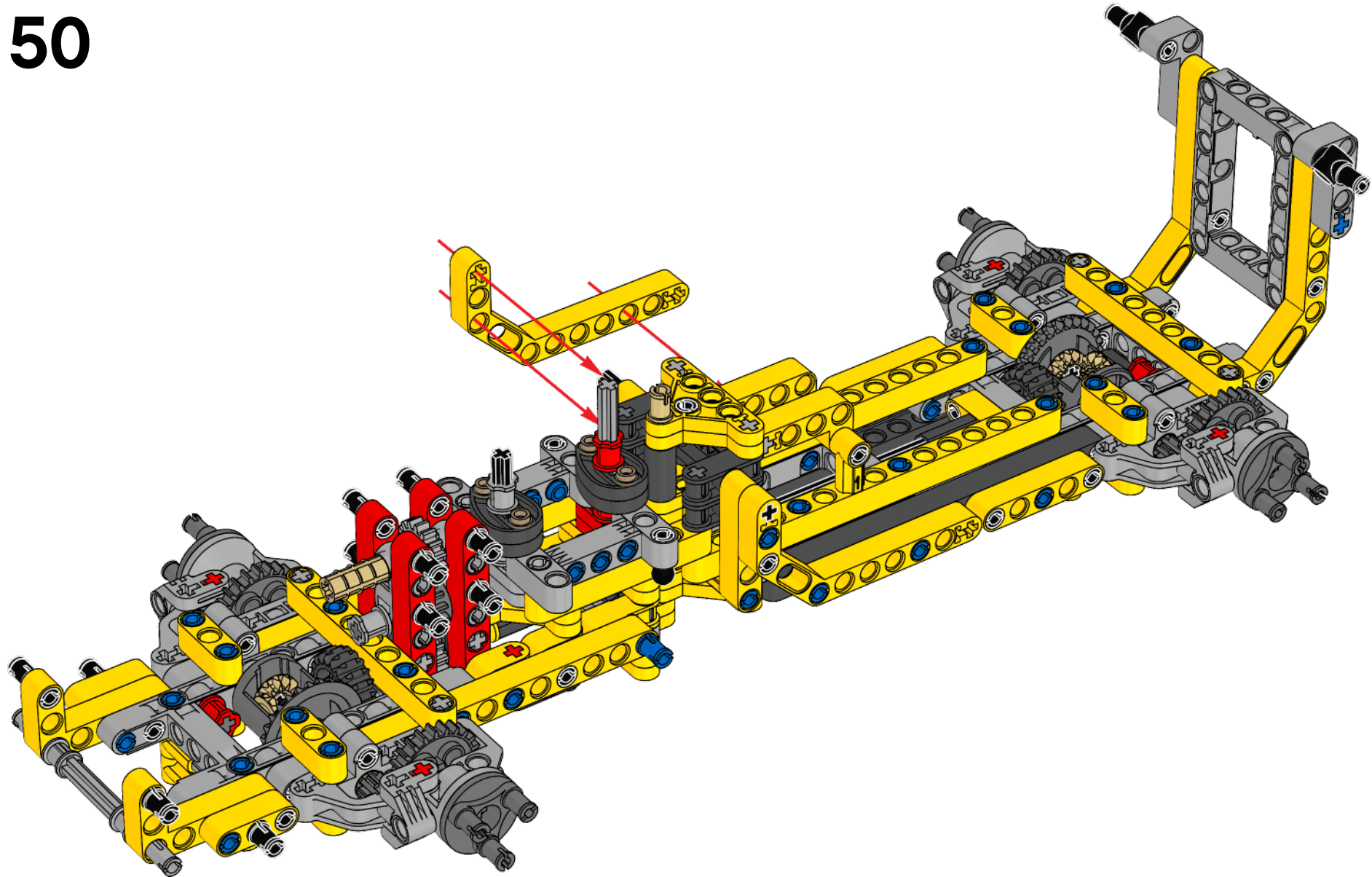

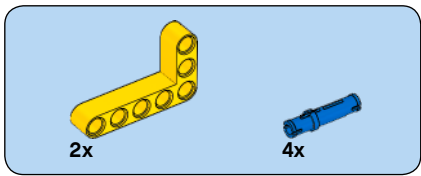

51

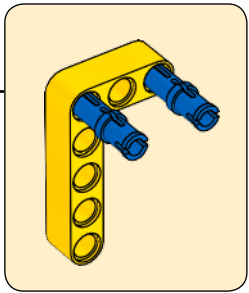
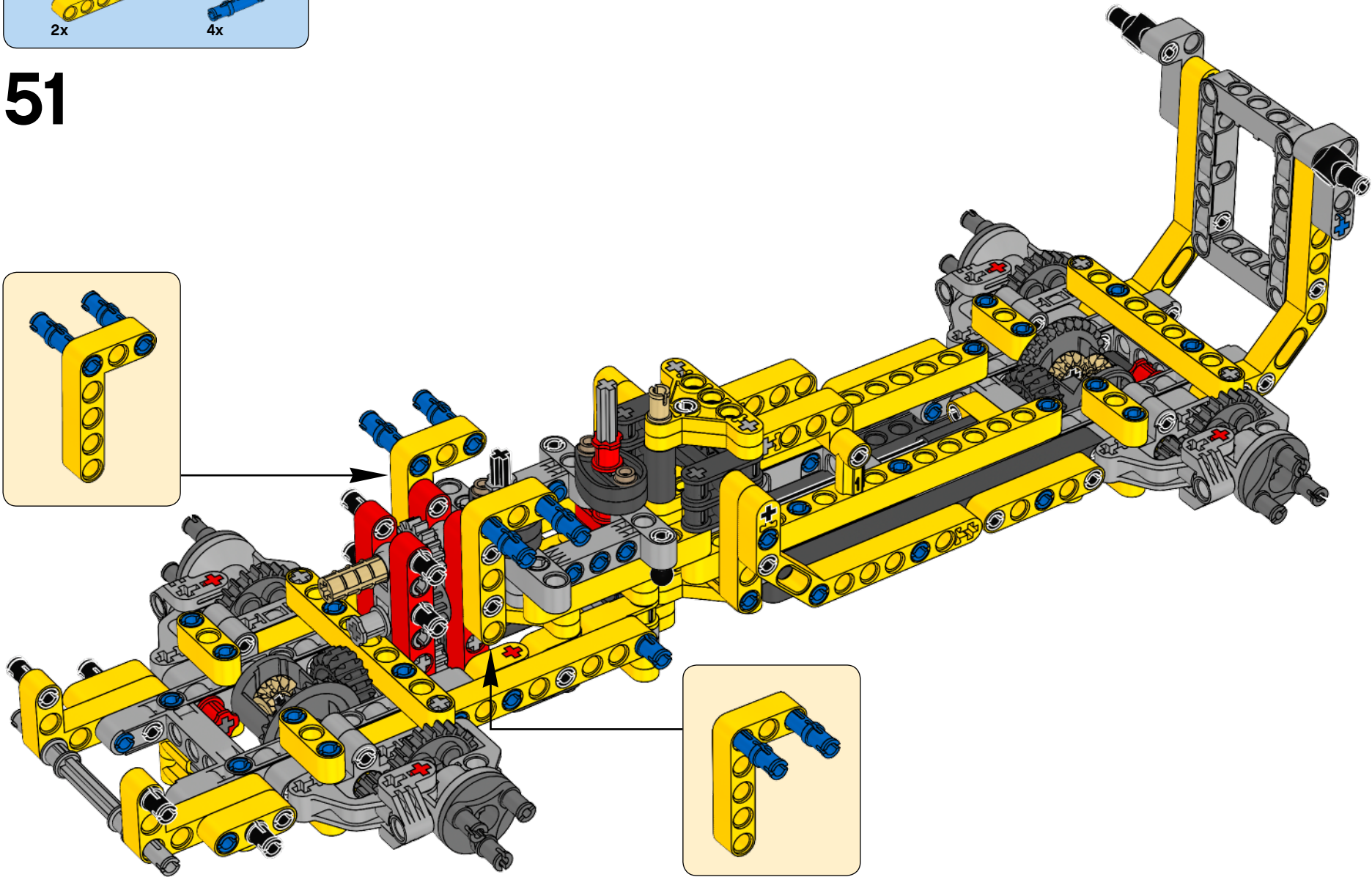
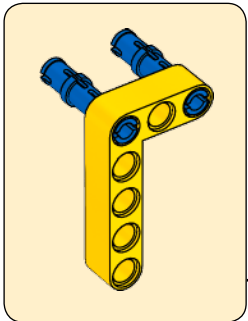

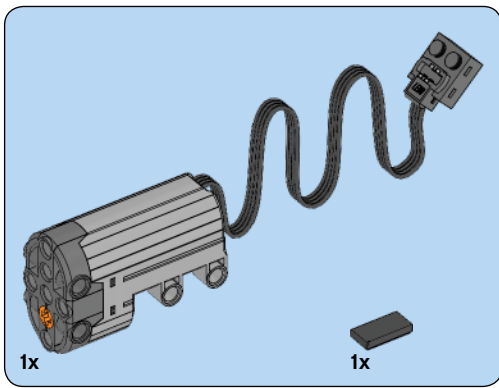

52

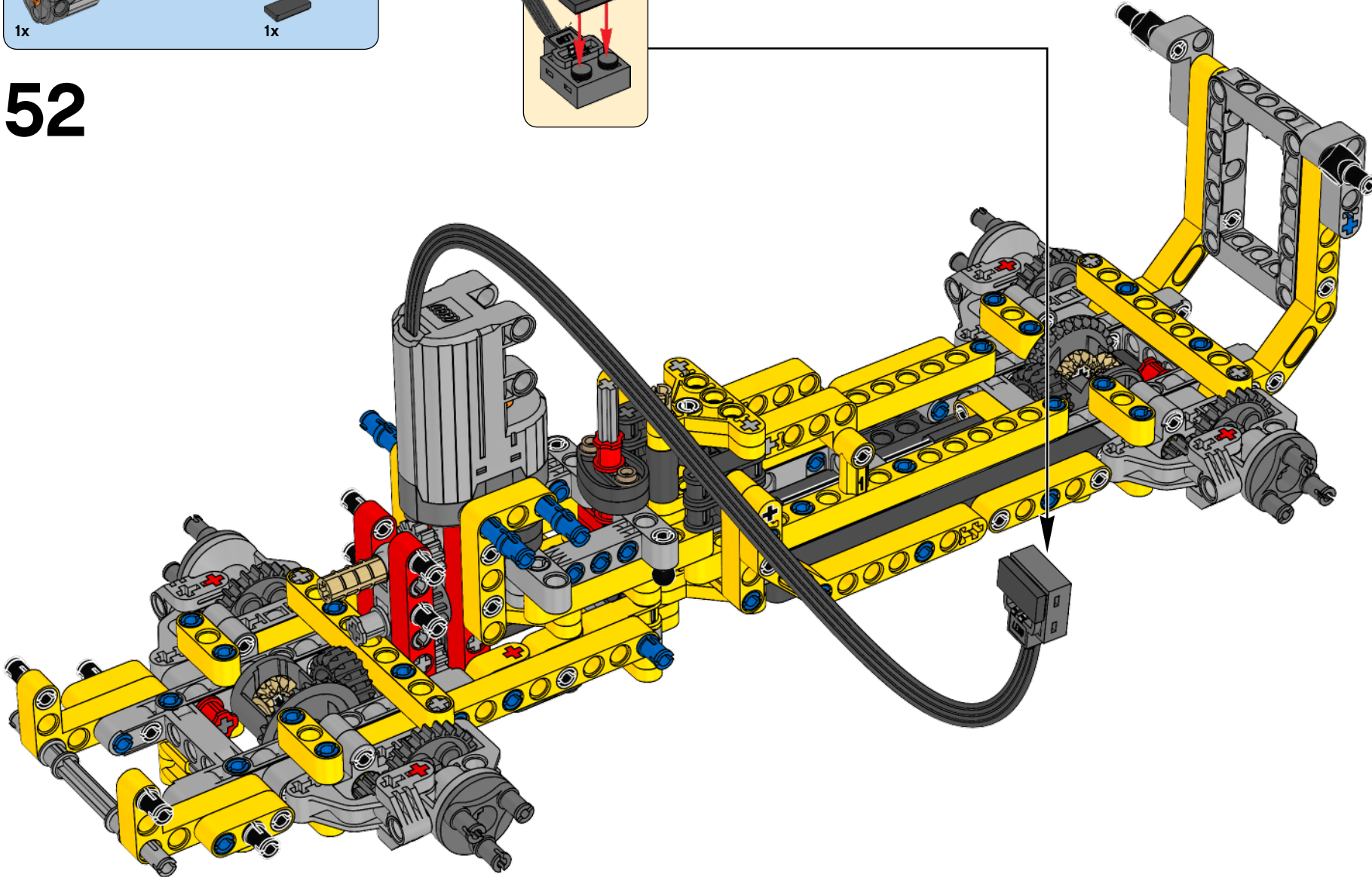
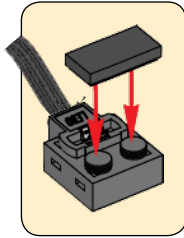

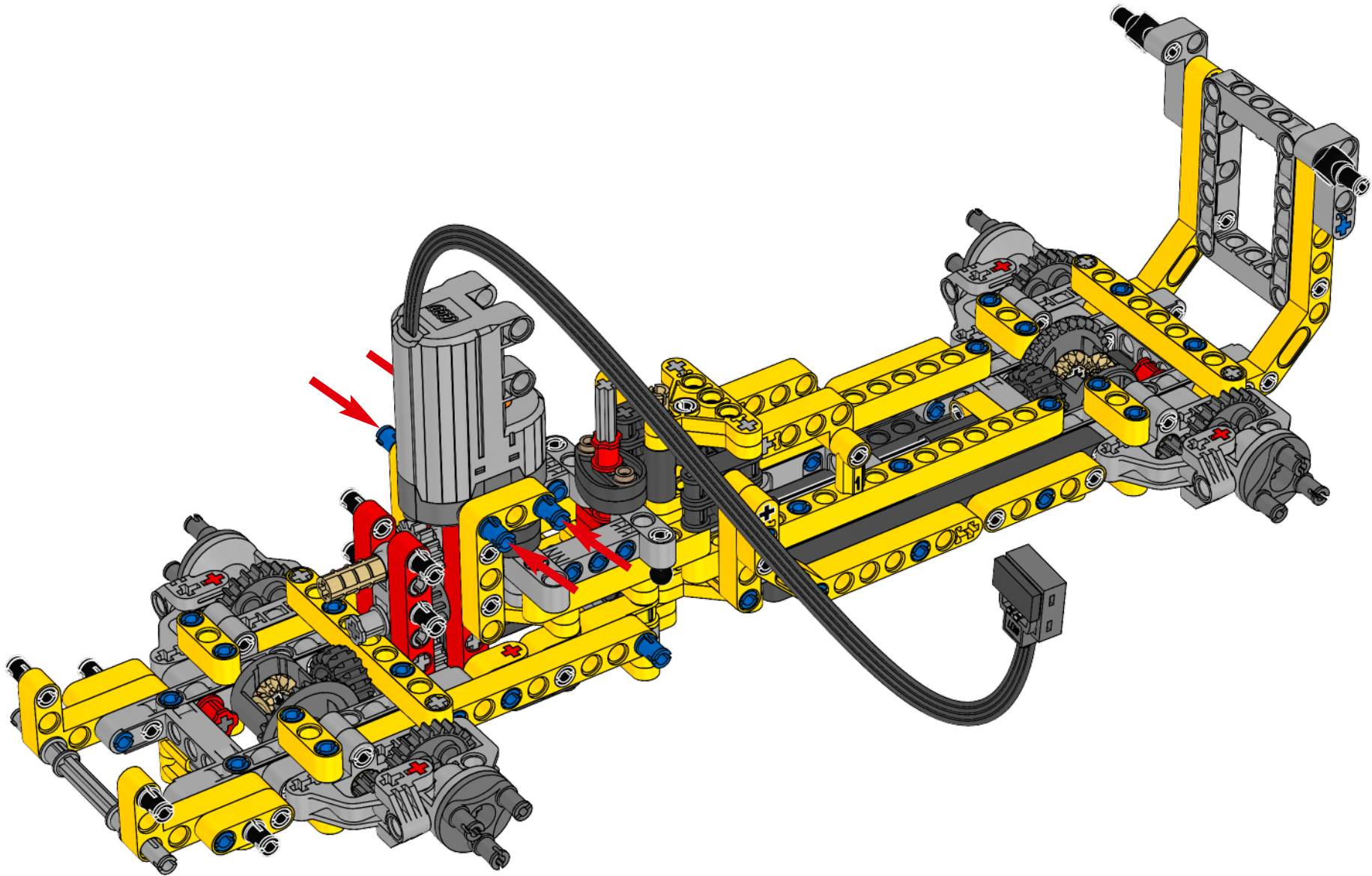

16

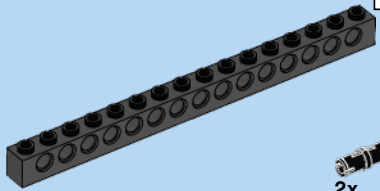

54

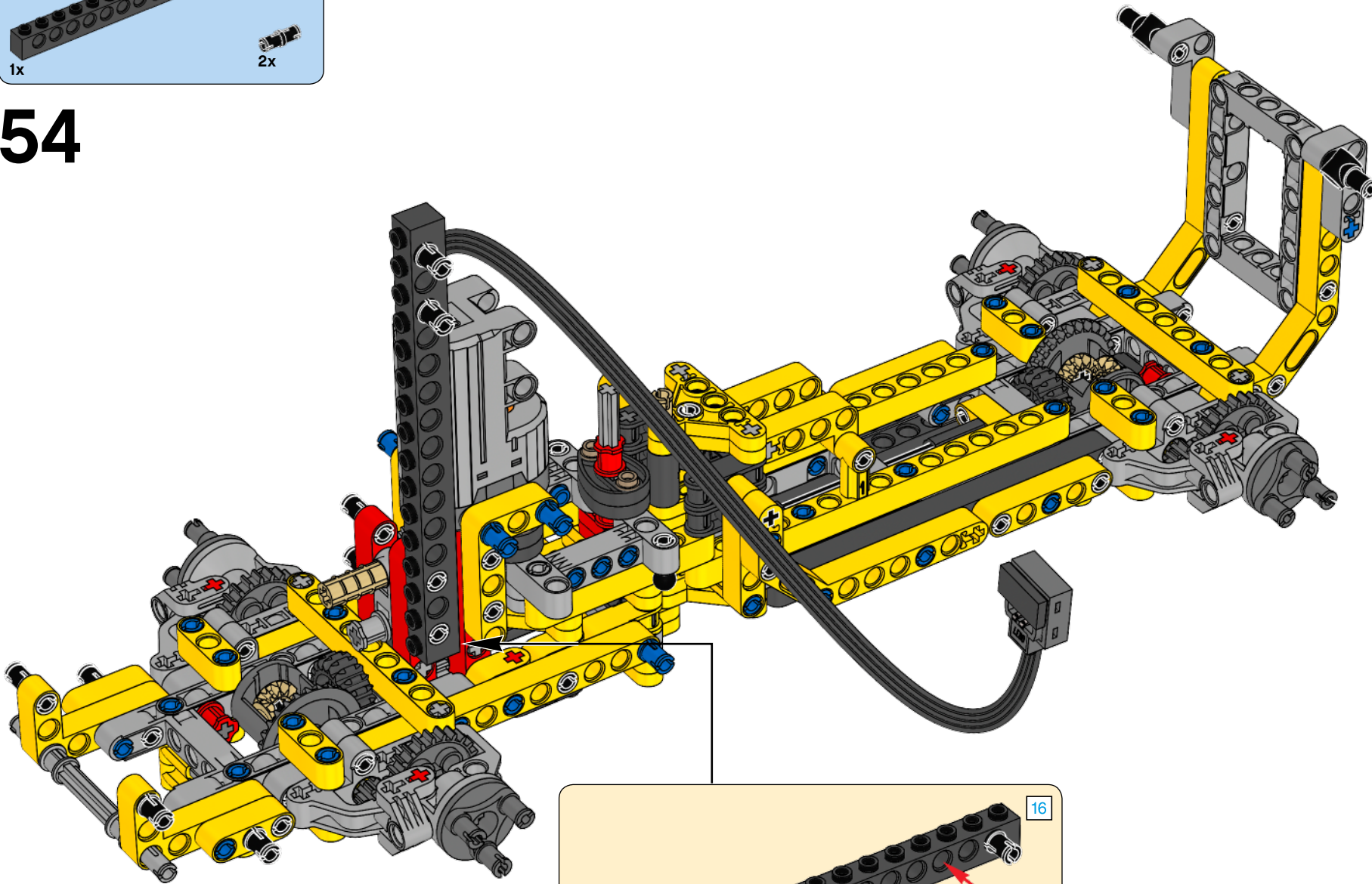

16

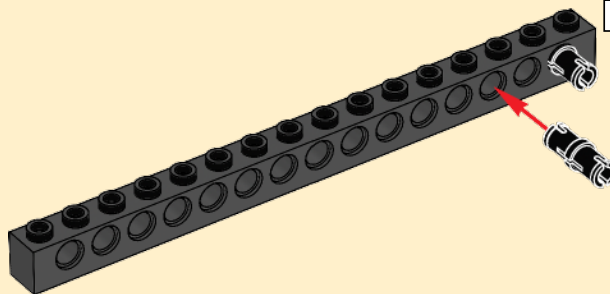

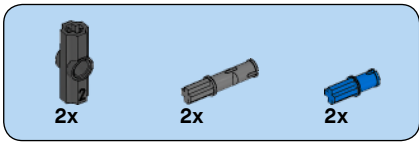

55

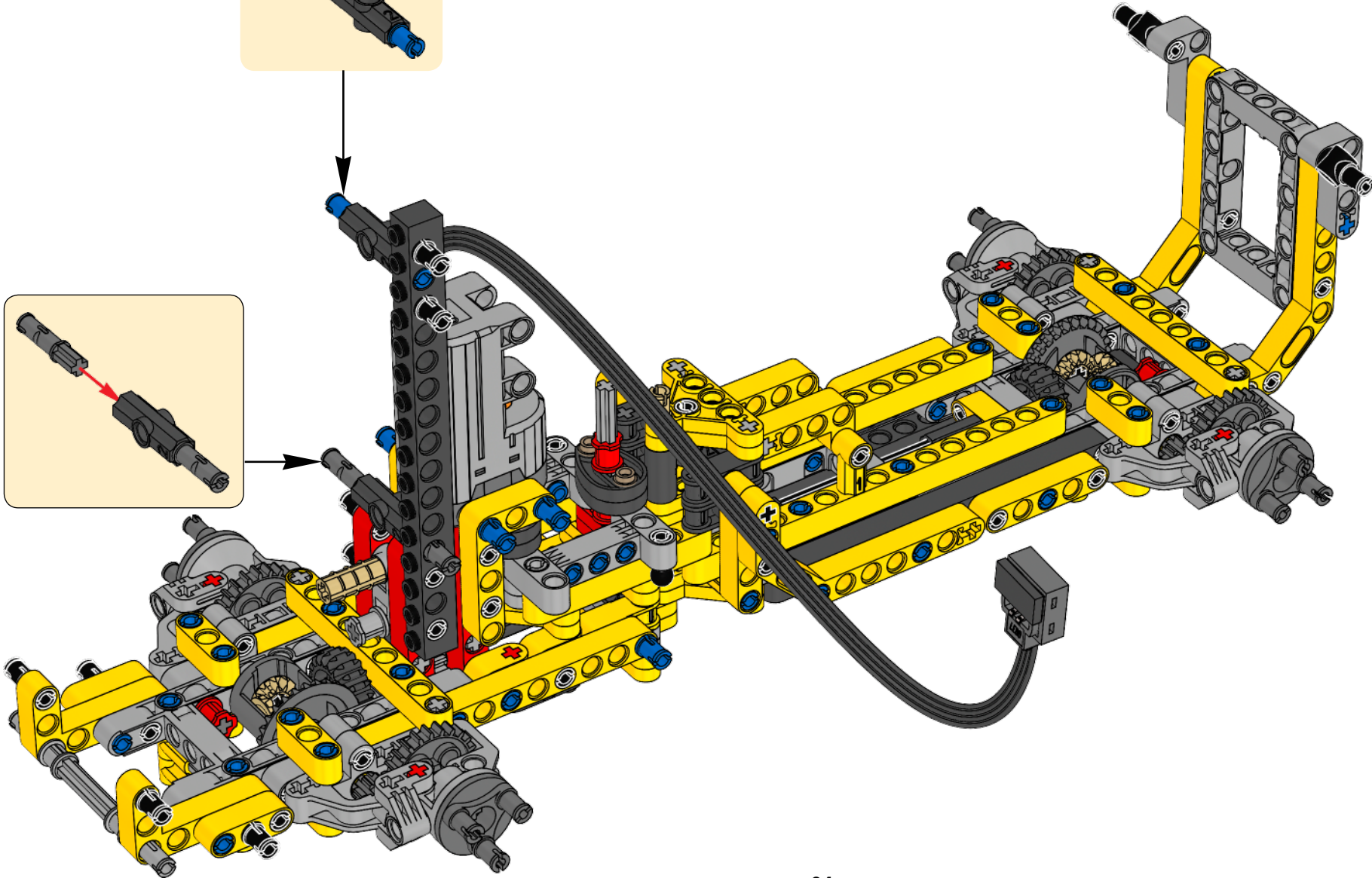
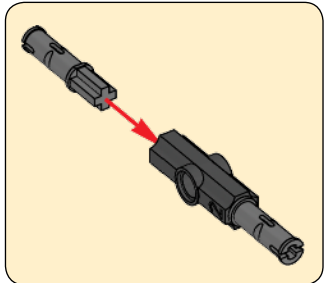
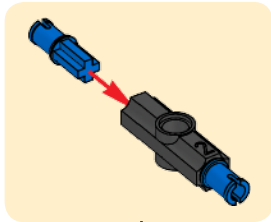

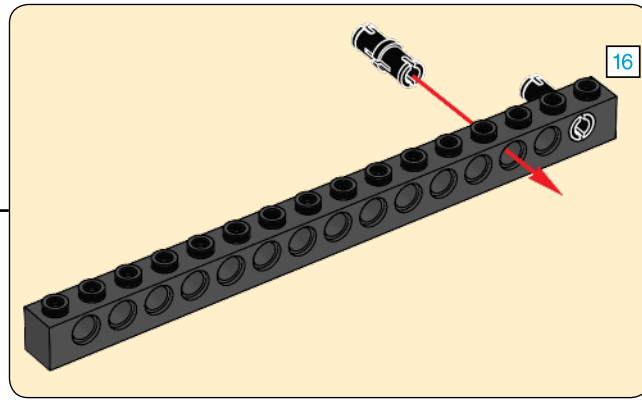
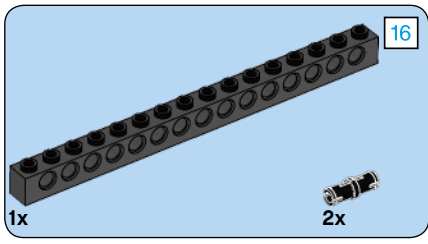

56

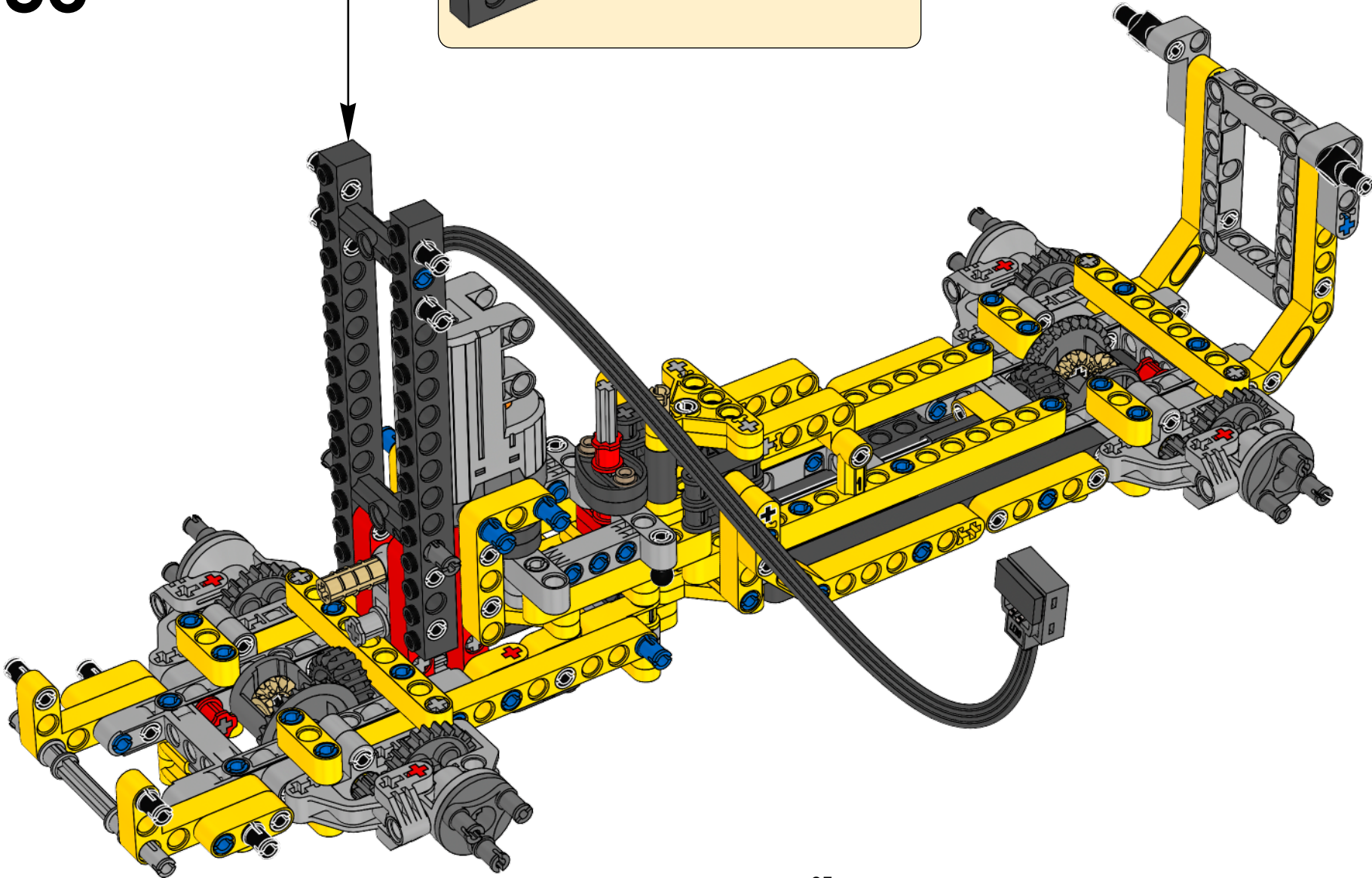

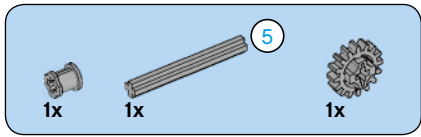

57

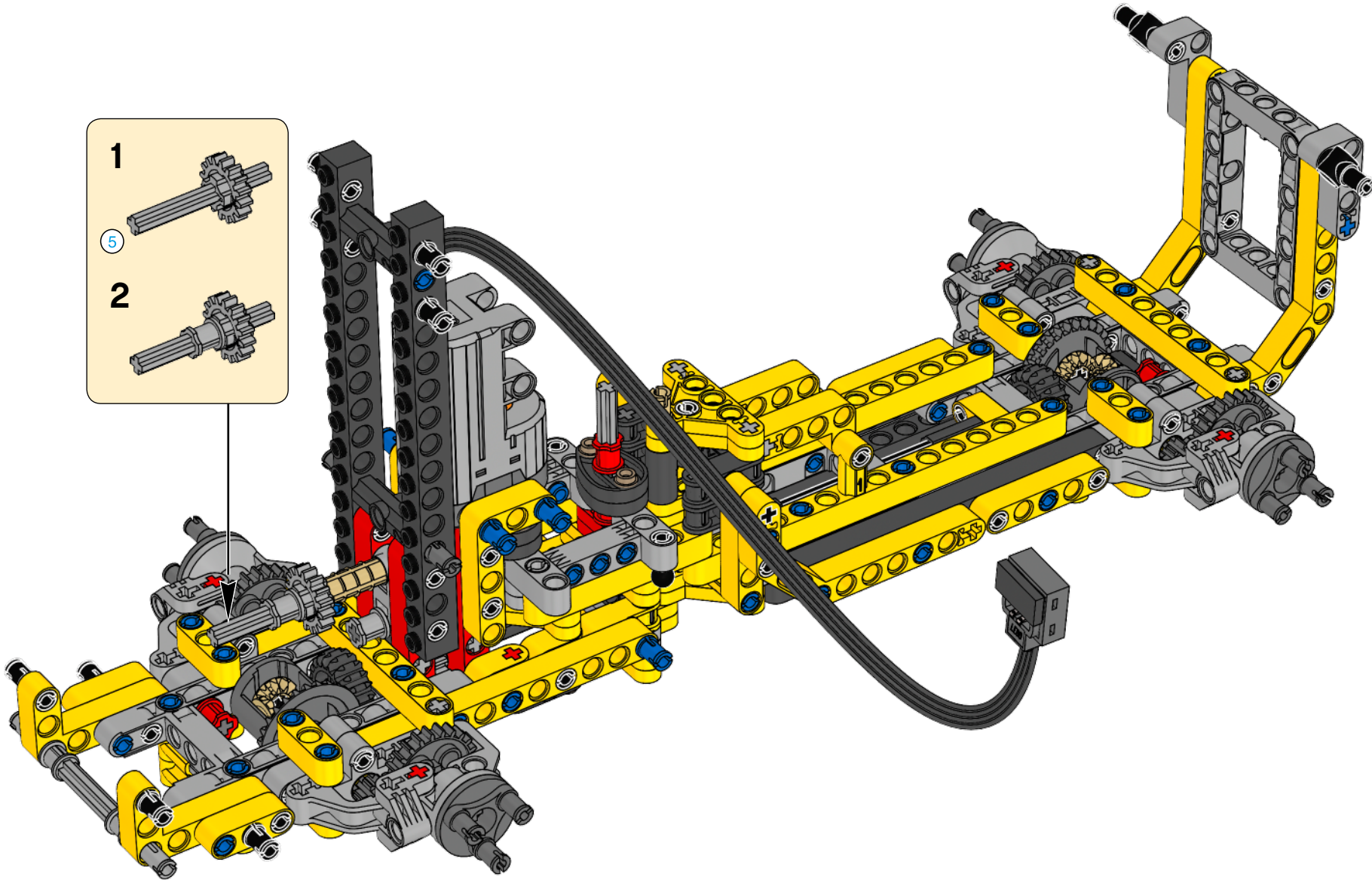
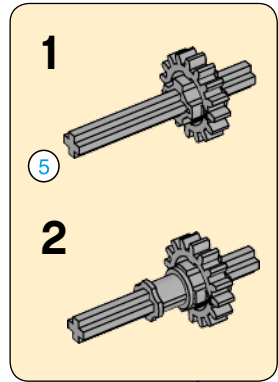

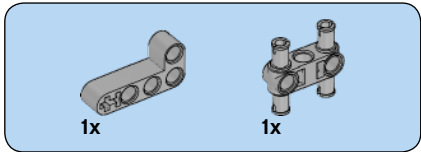
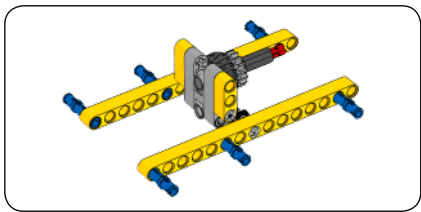

1

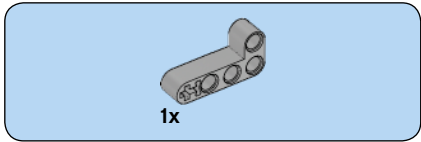
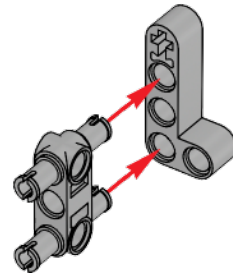

2

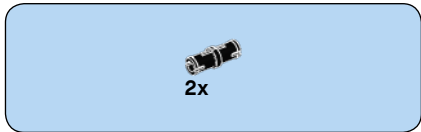
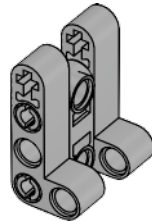

3

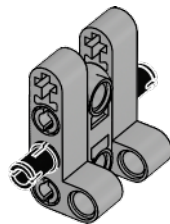

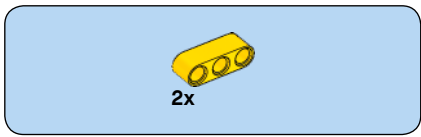

4

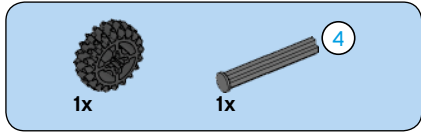
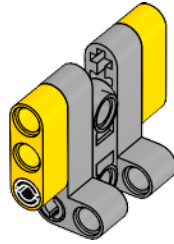

5

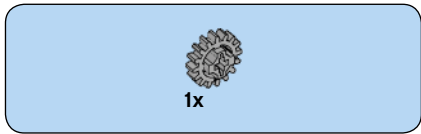
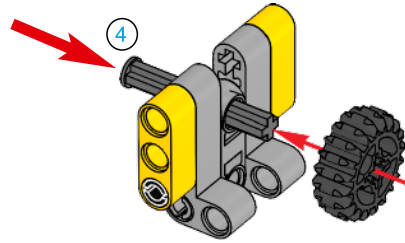

6

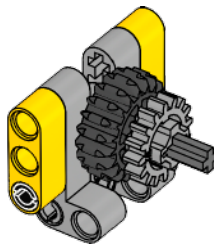

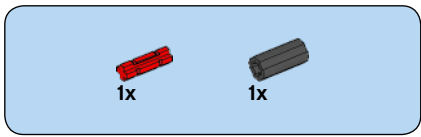

7

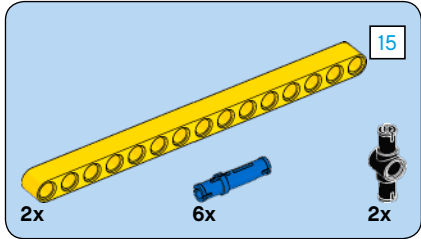
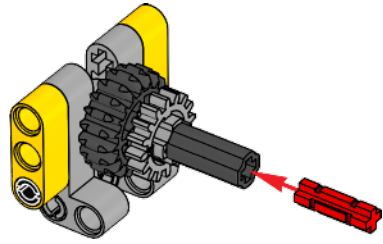

8

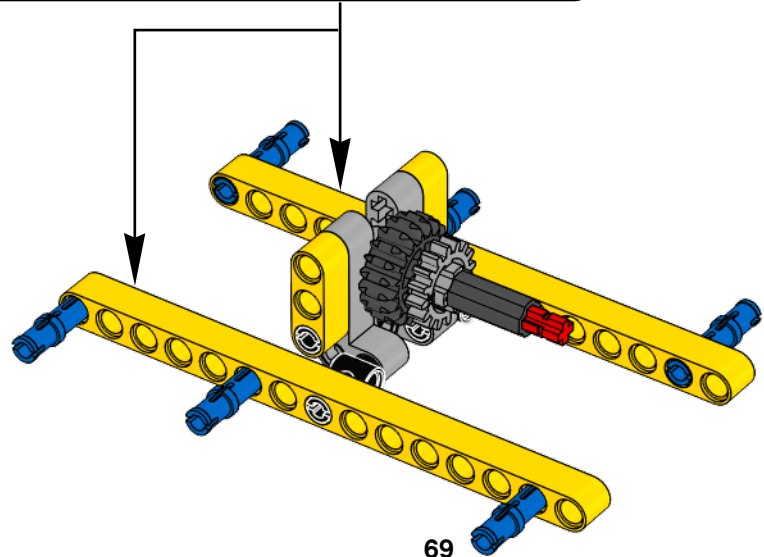
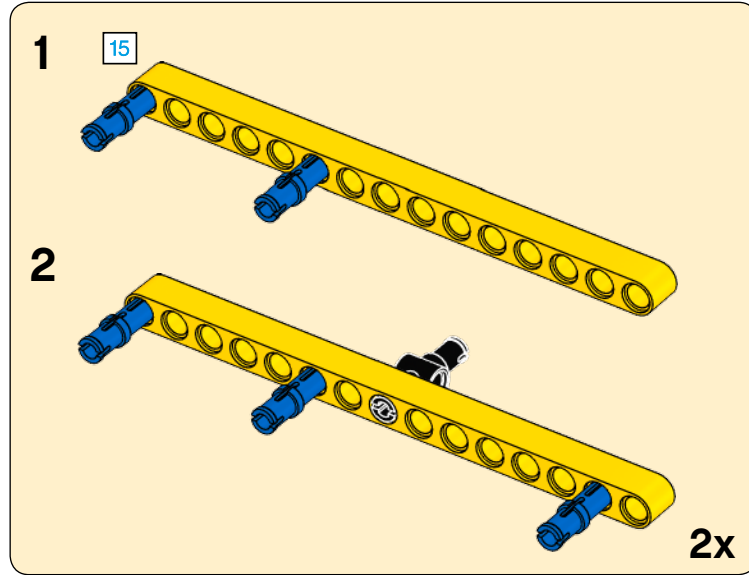

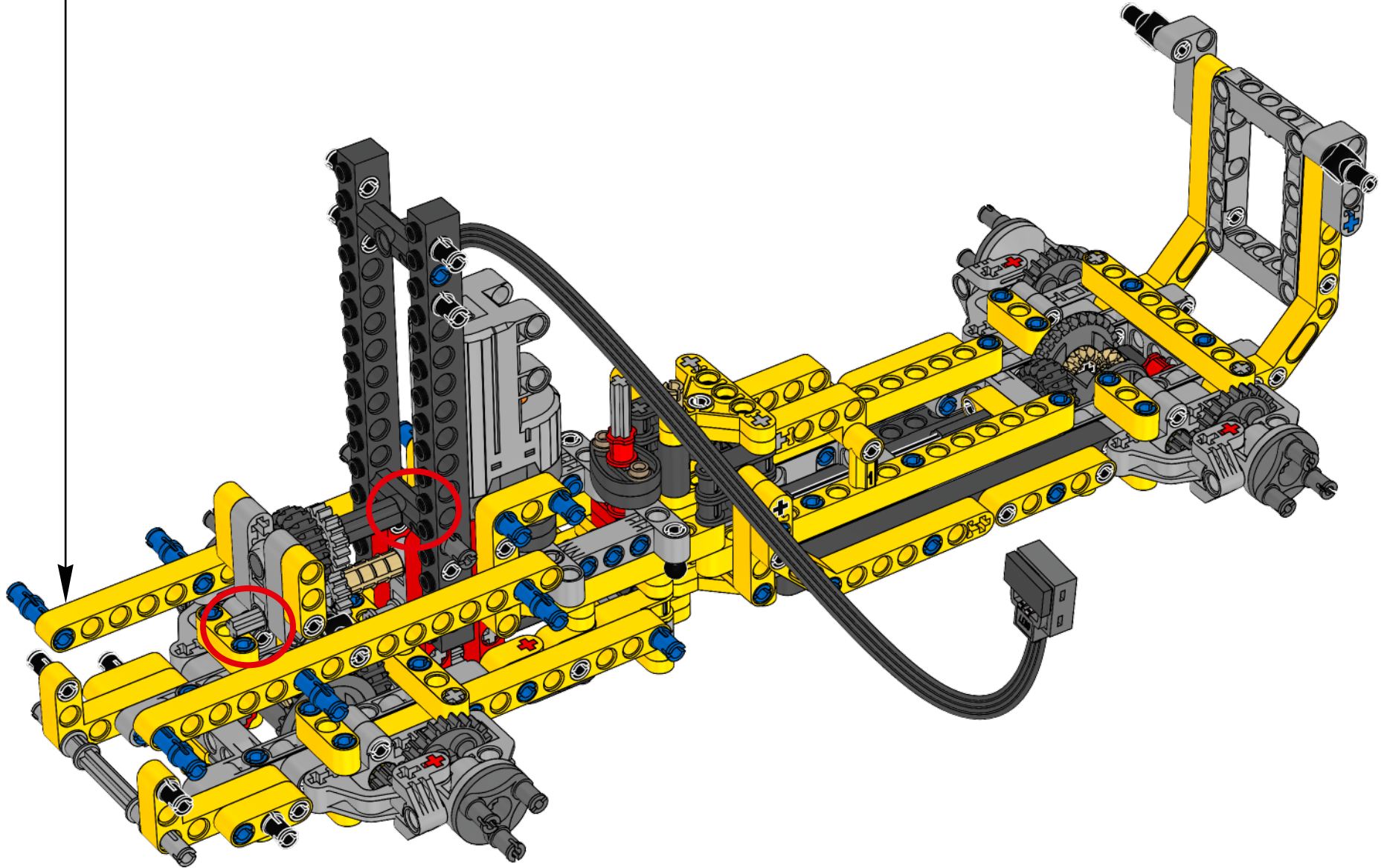

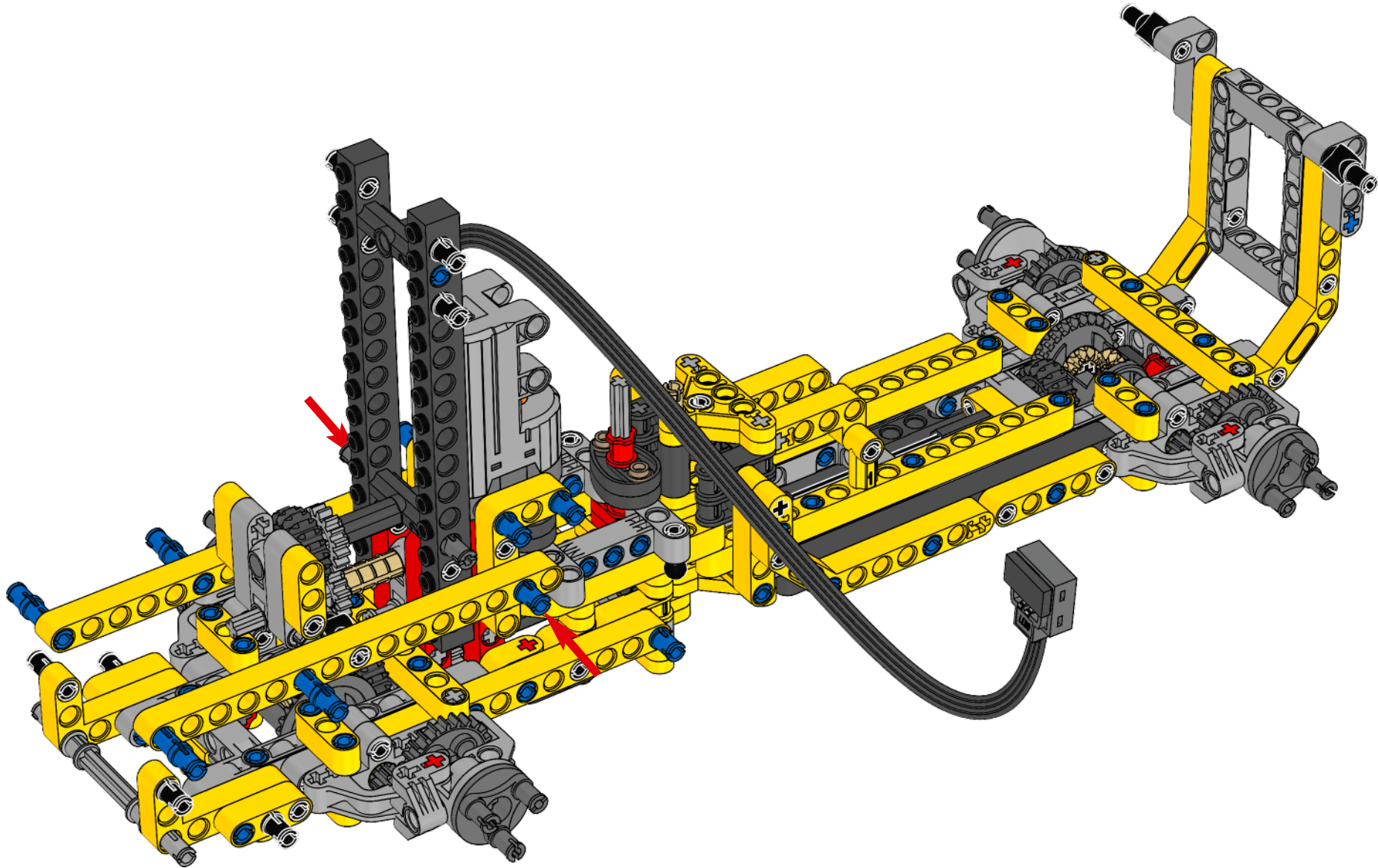

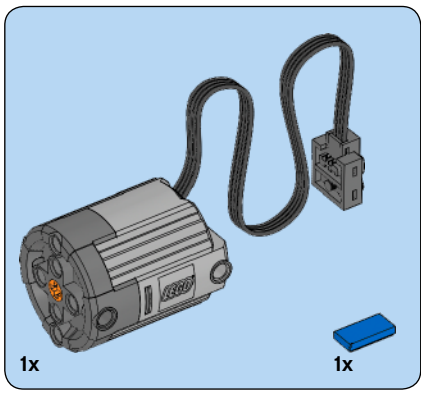

60

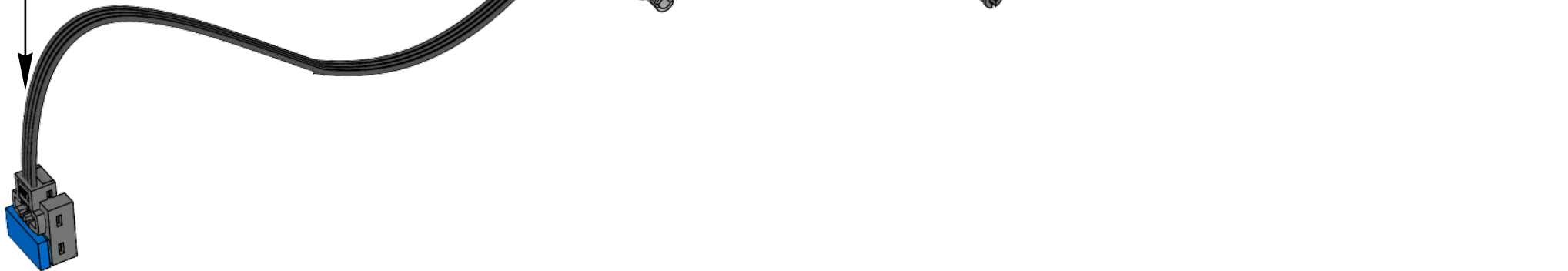
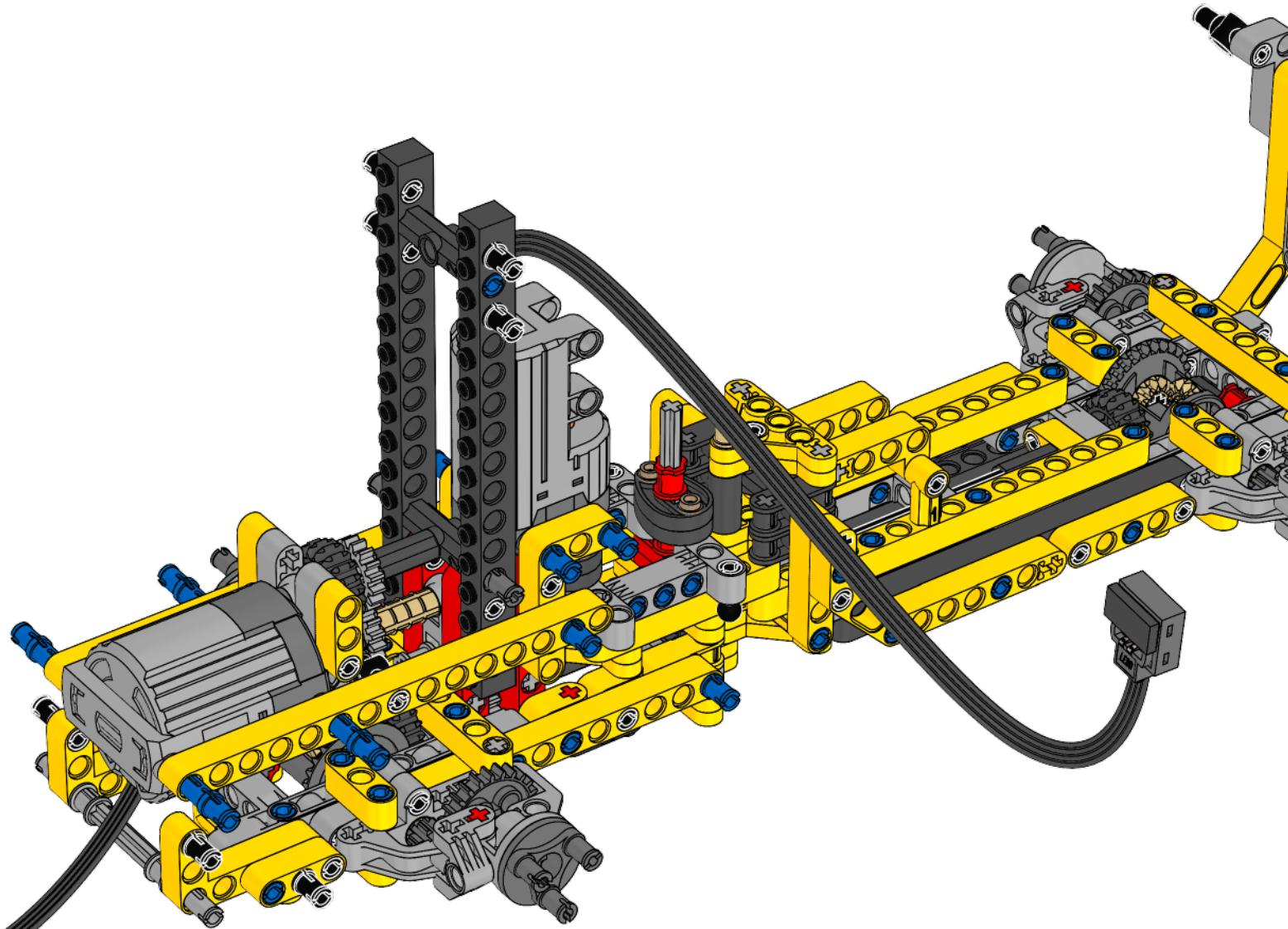
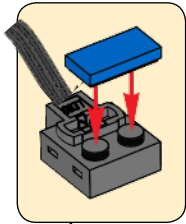

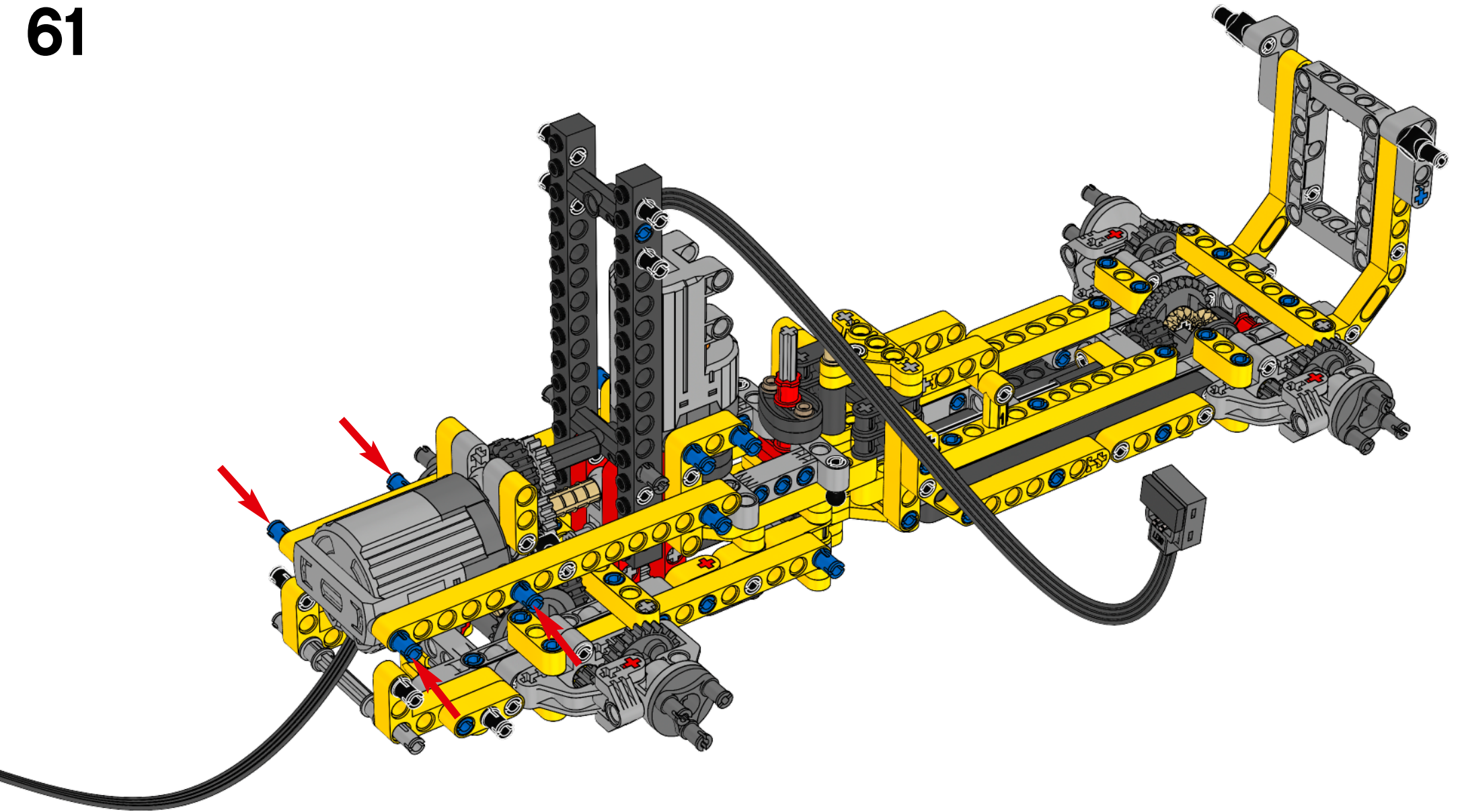

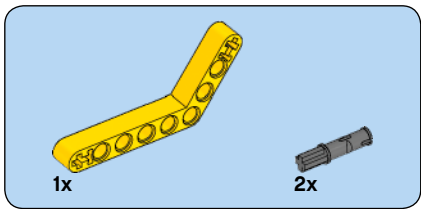

62

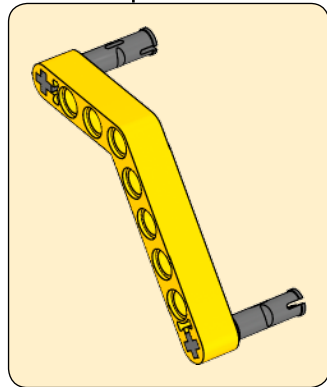
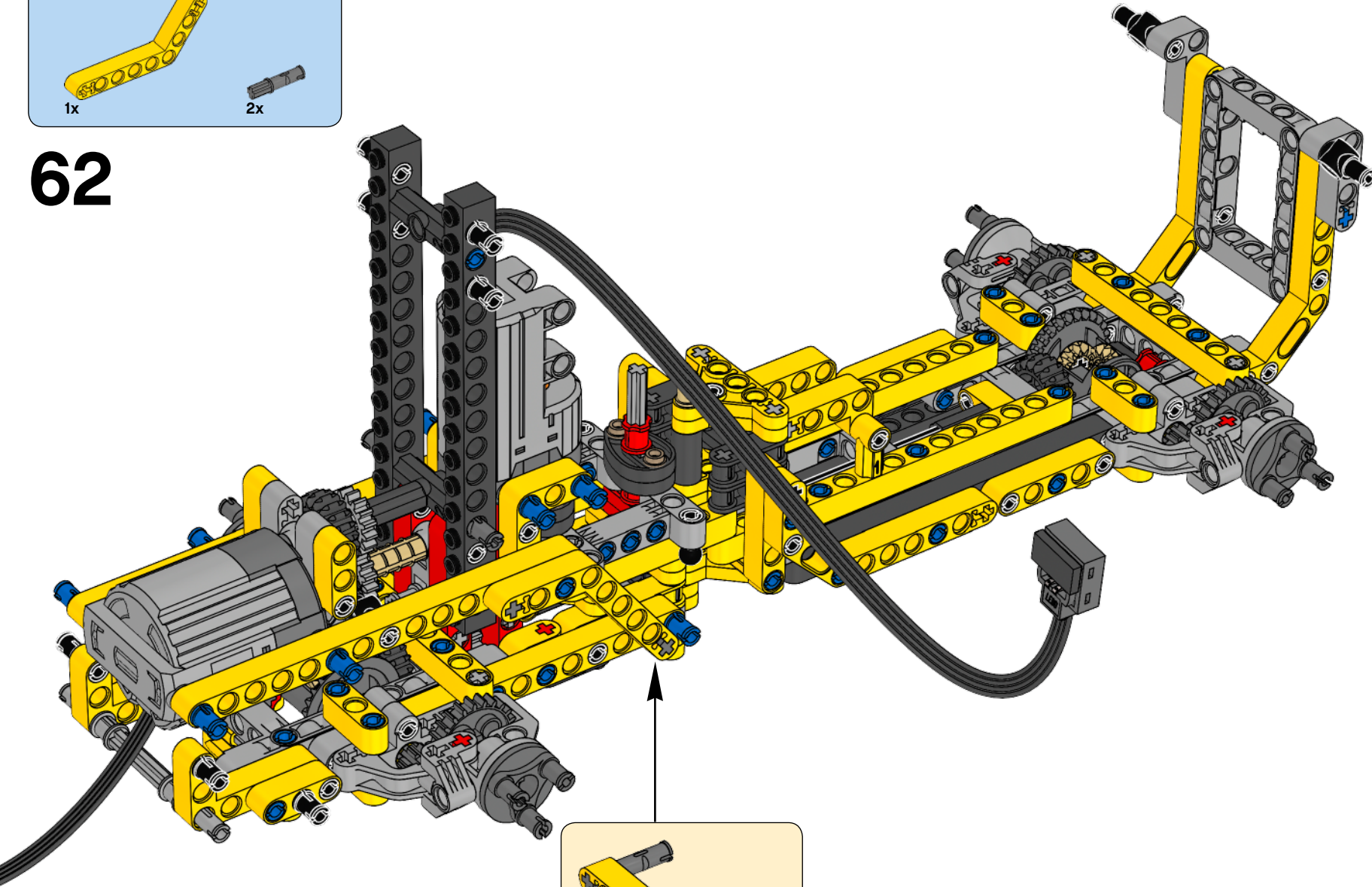

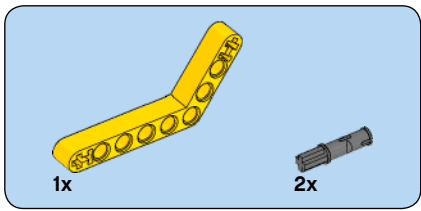

63

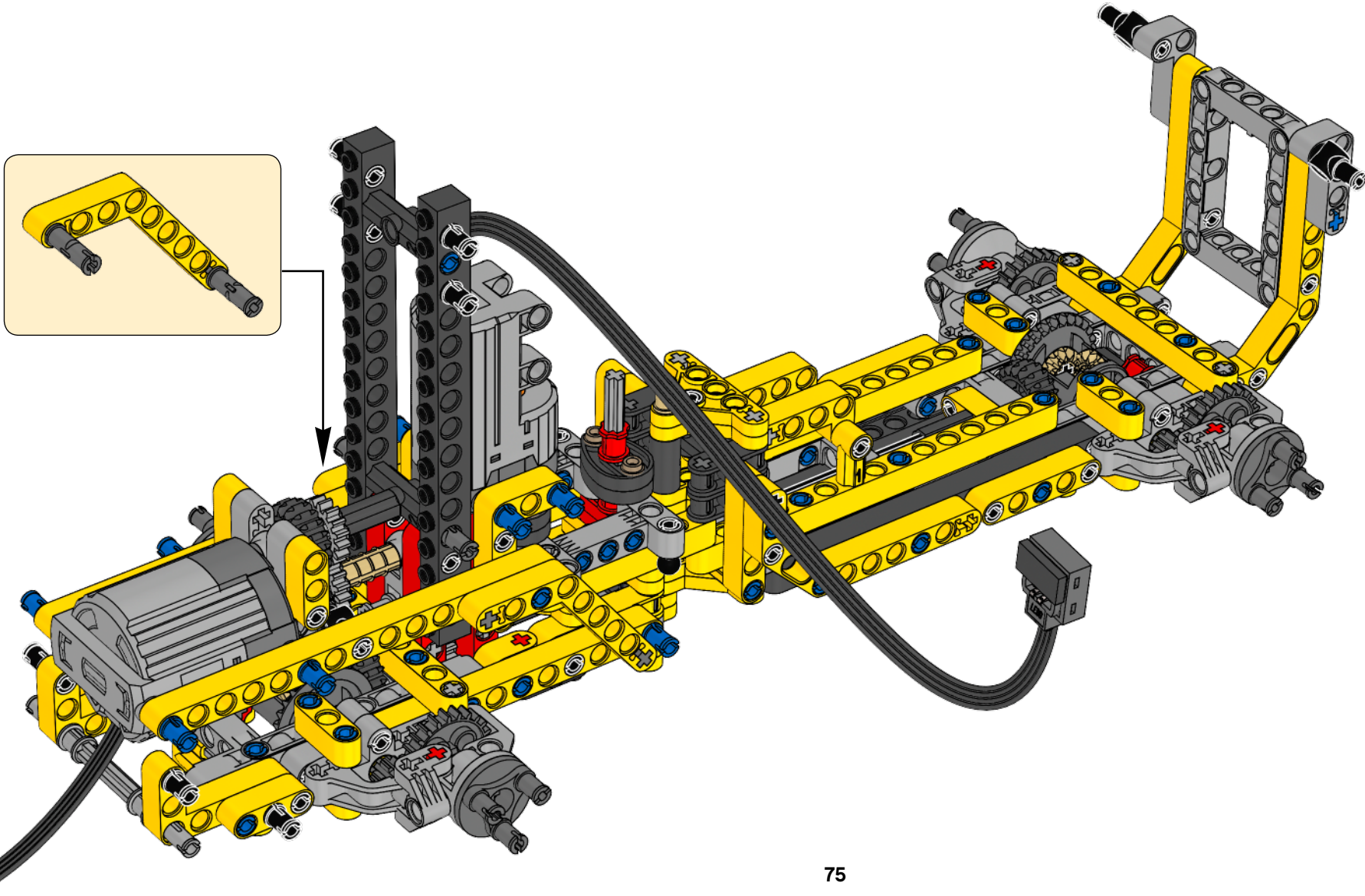

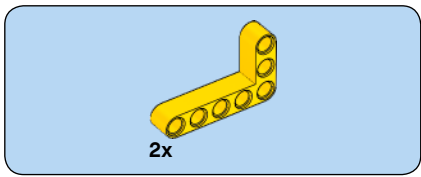

64

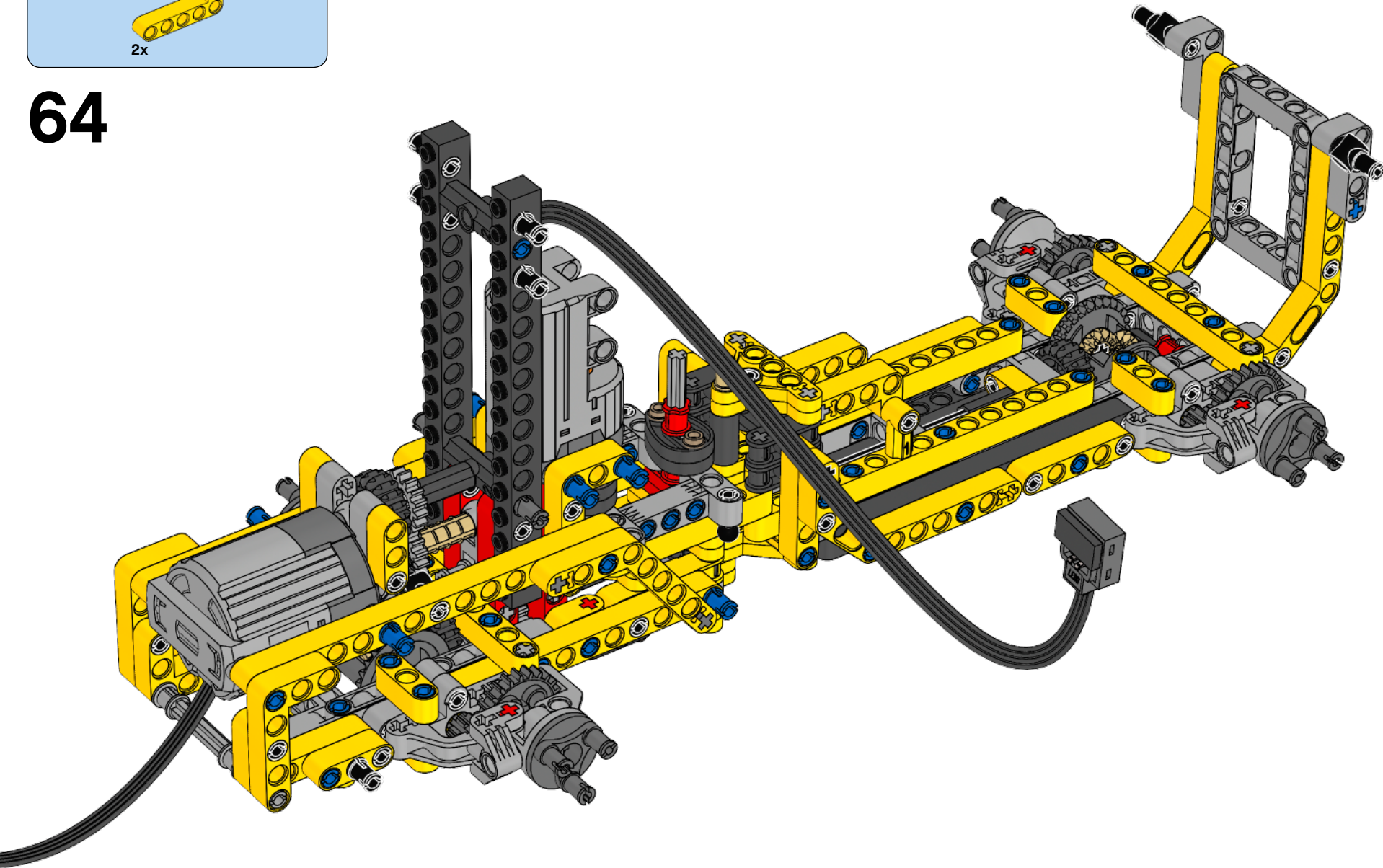

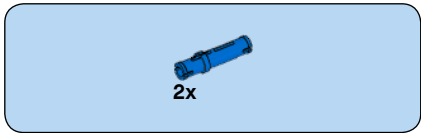

65

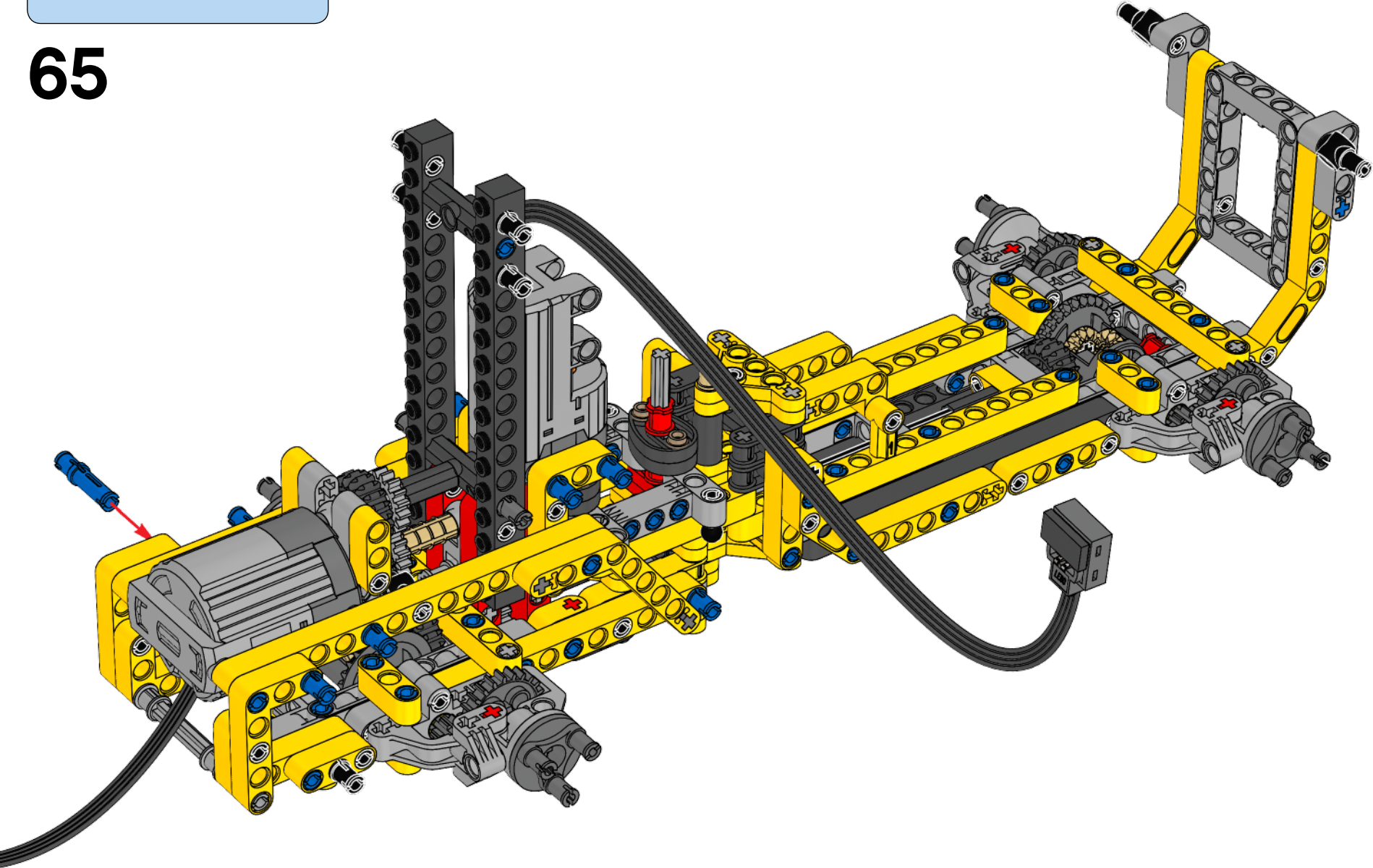

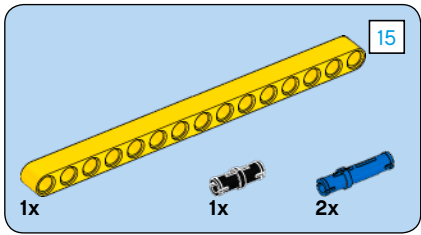

66

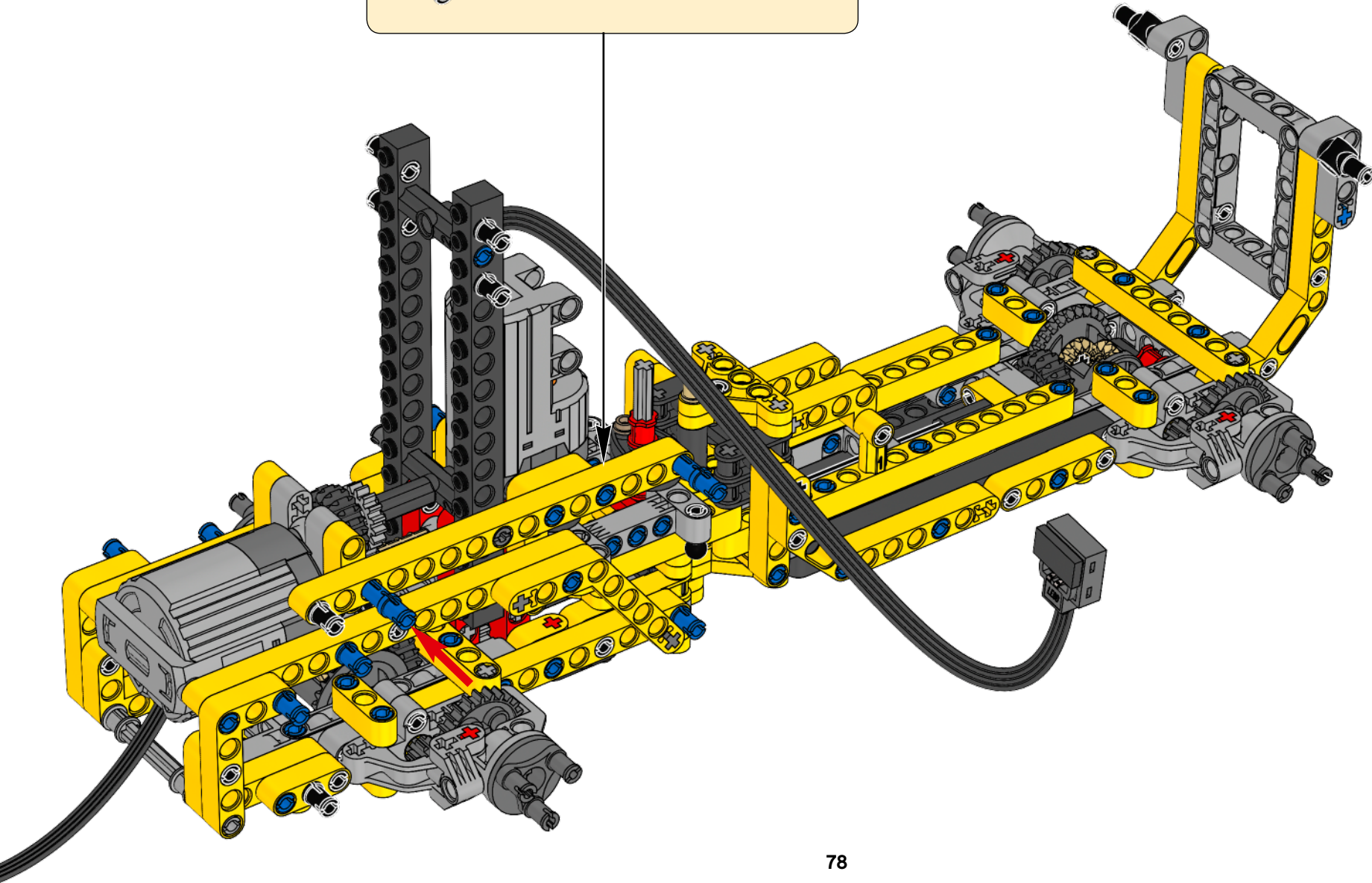
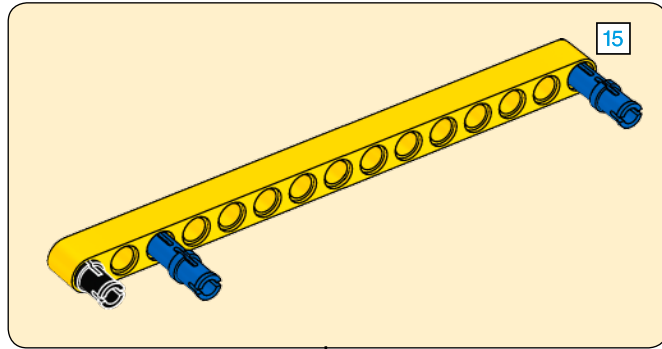

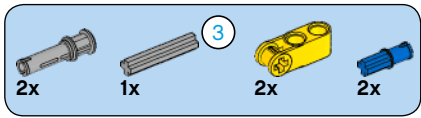

67

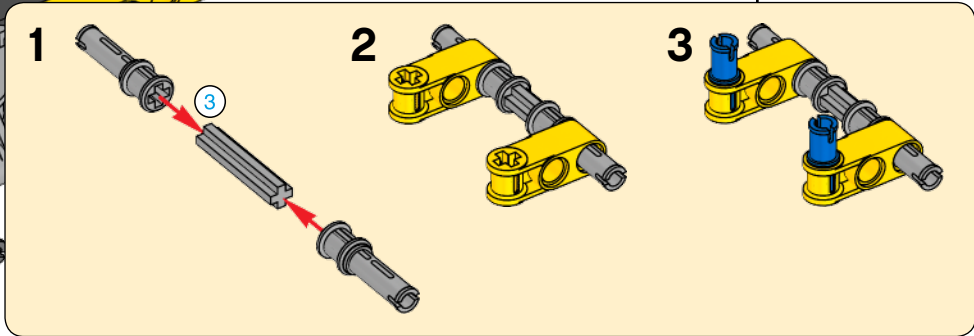
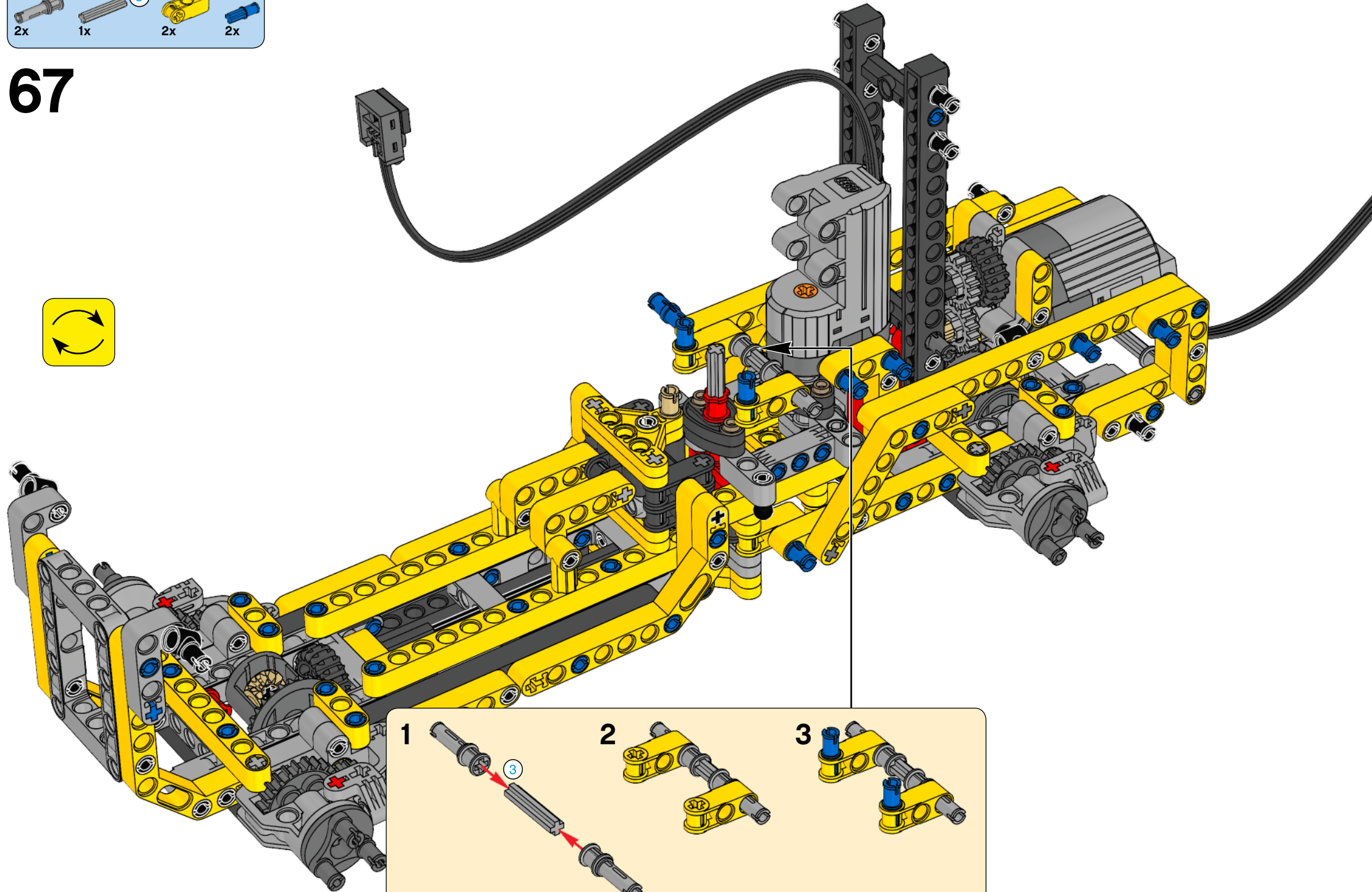

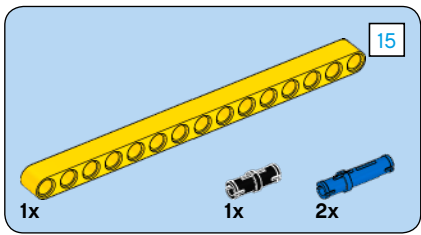

68

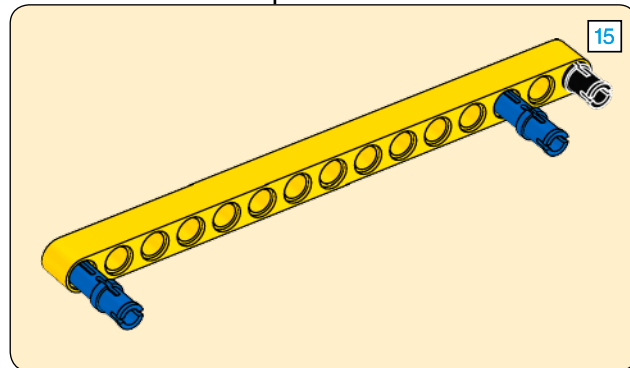
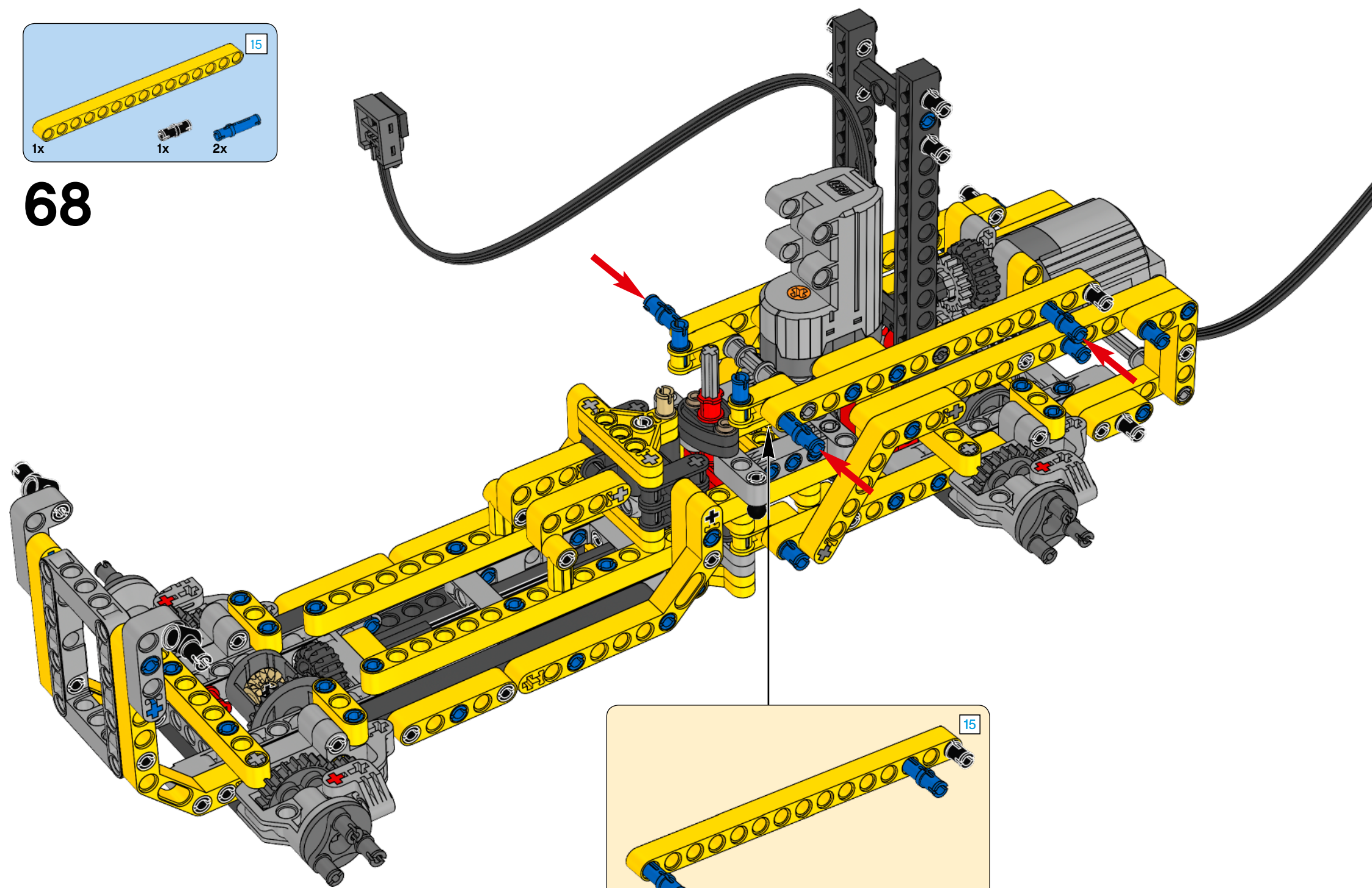

80

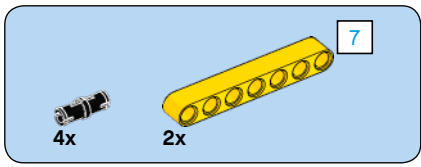

69

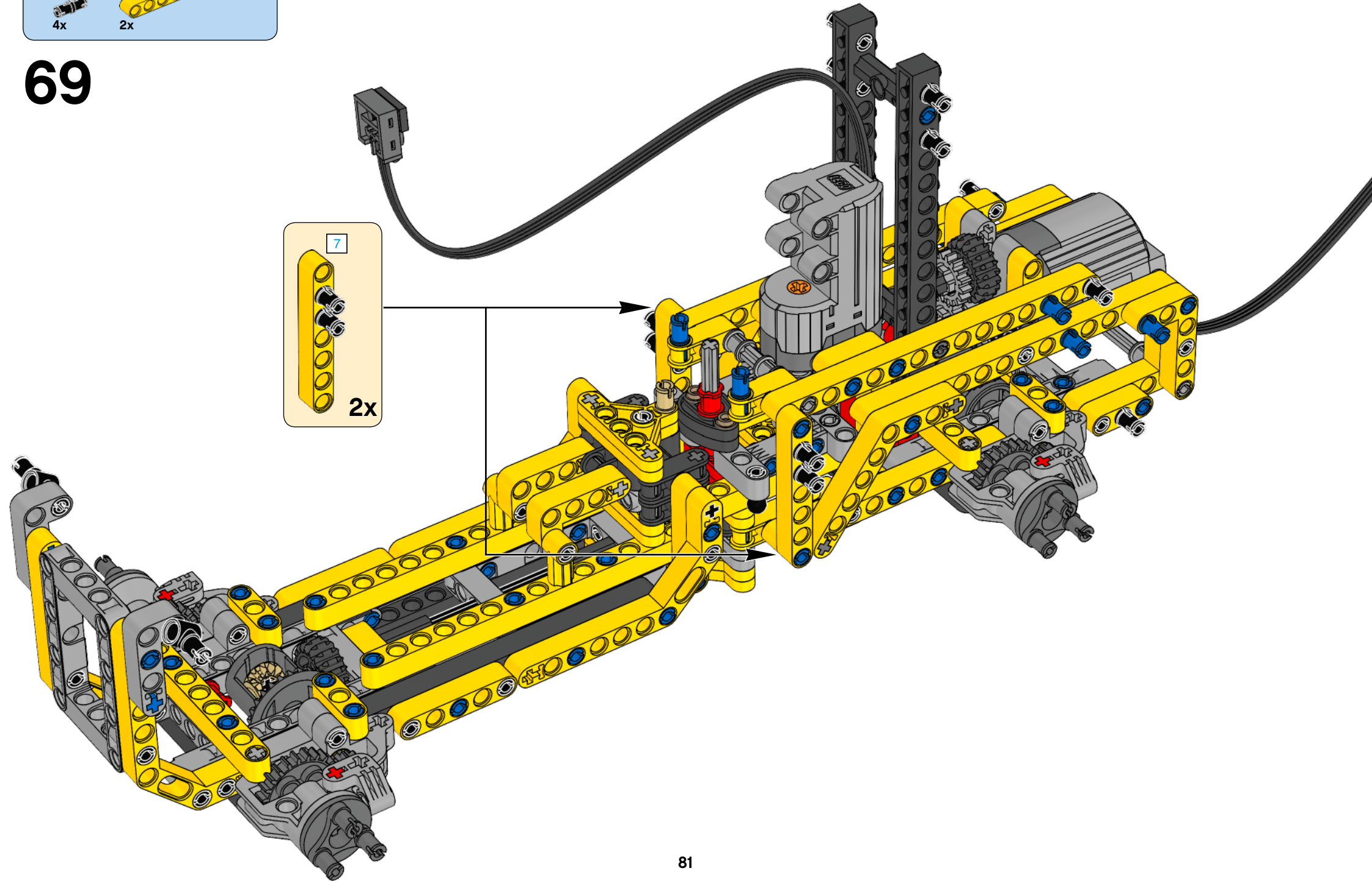
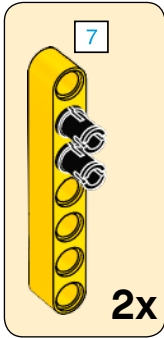

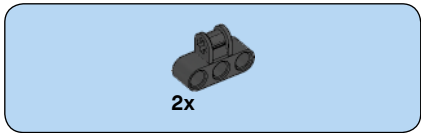

70

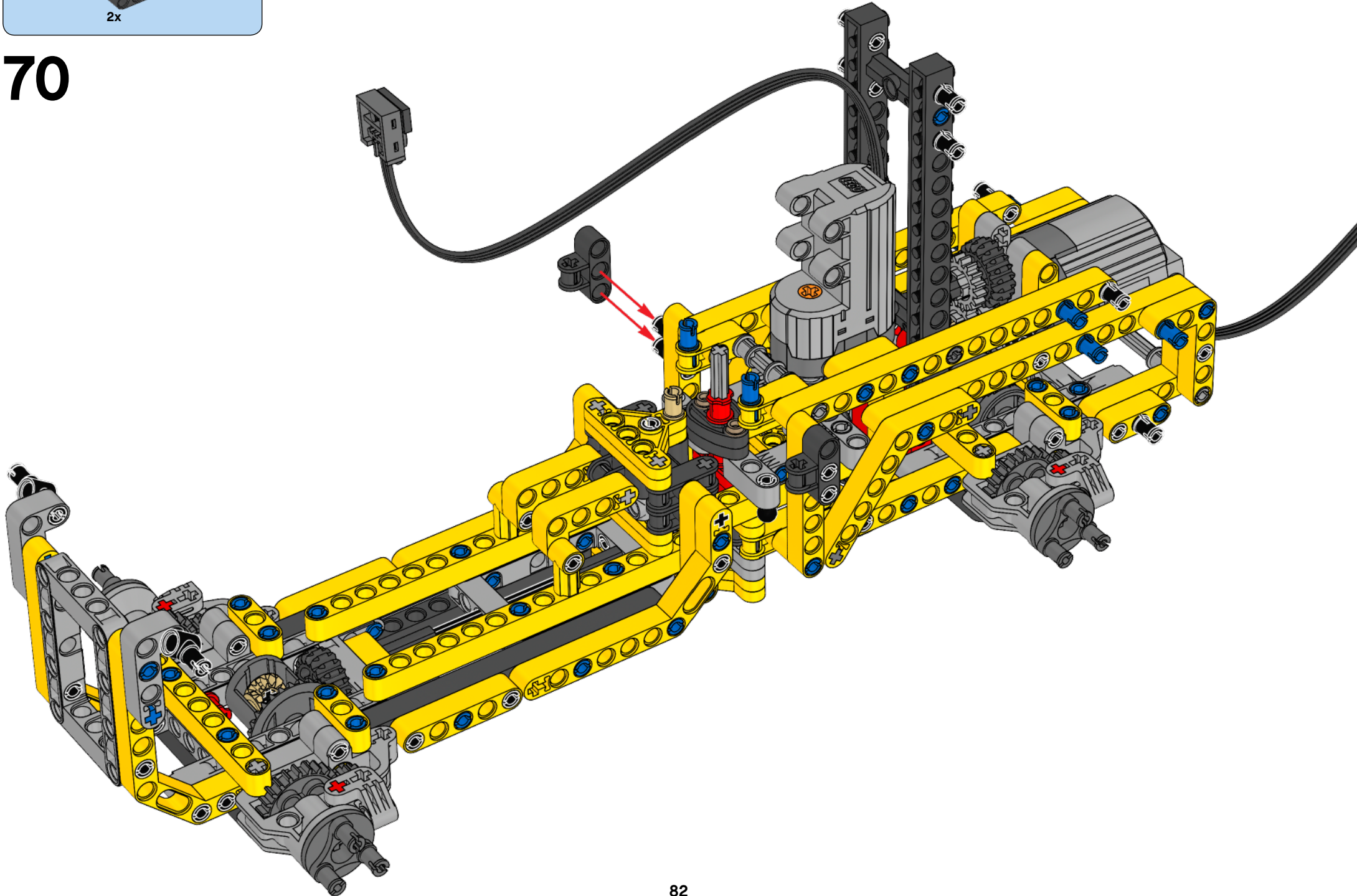

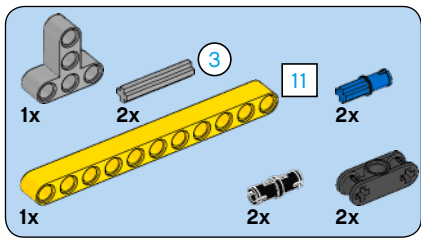

71

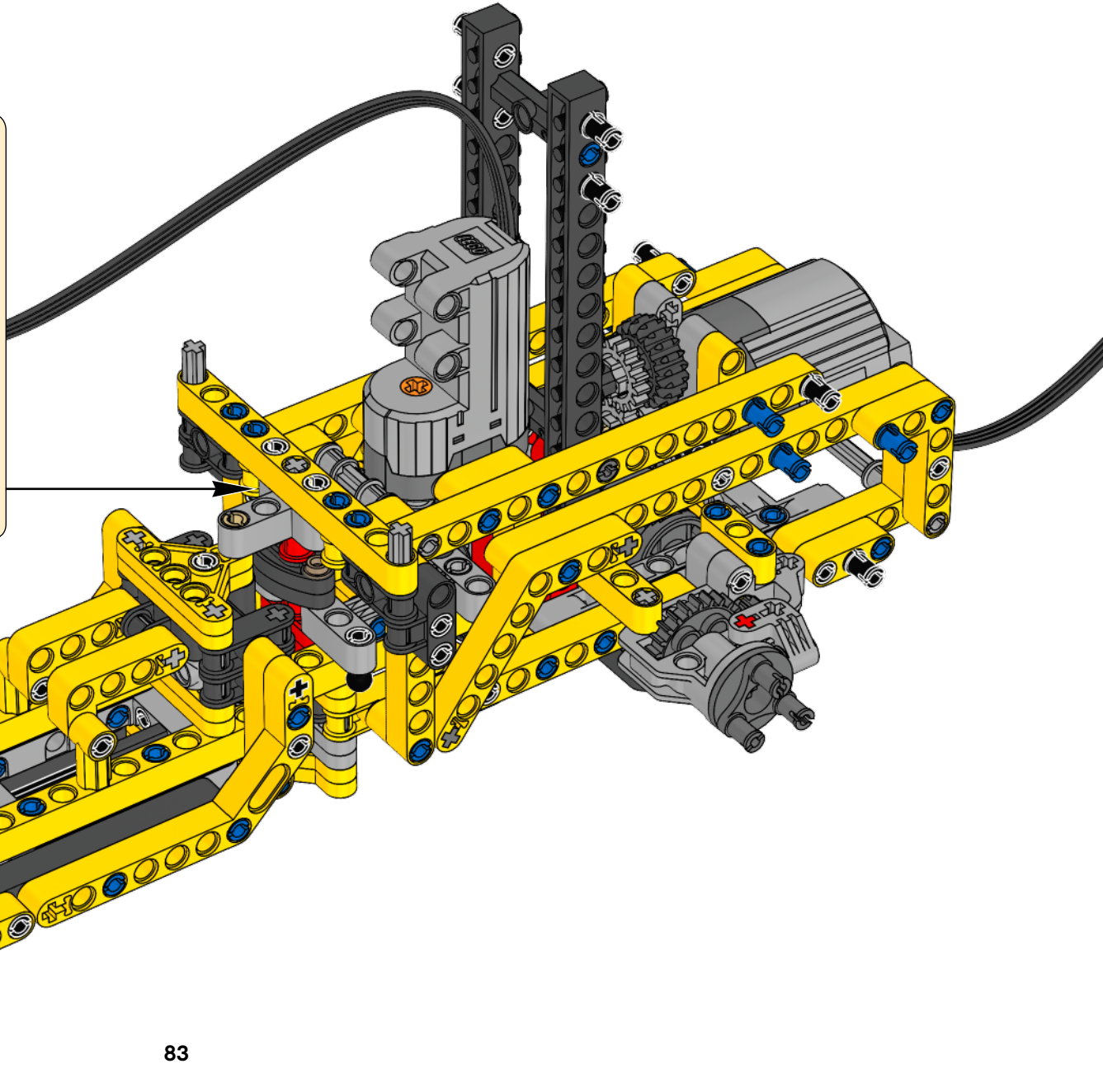
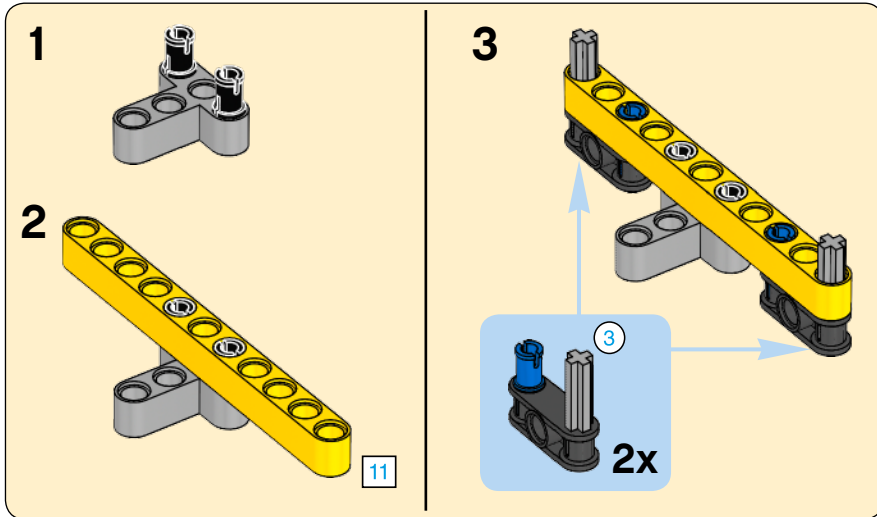

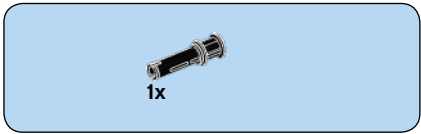

72

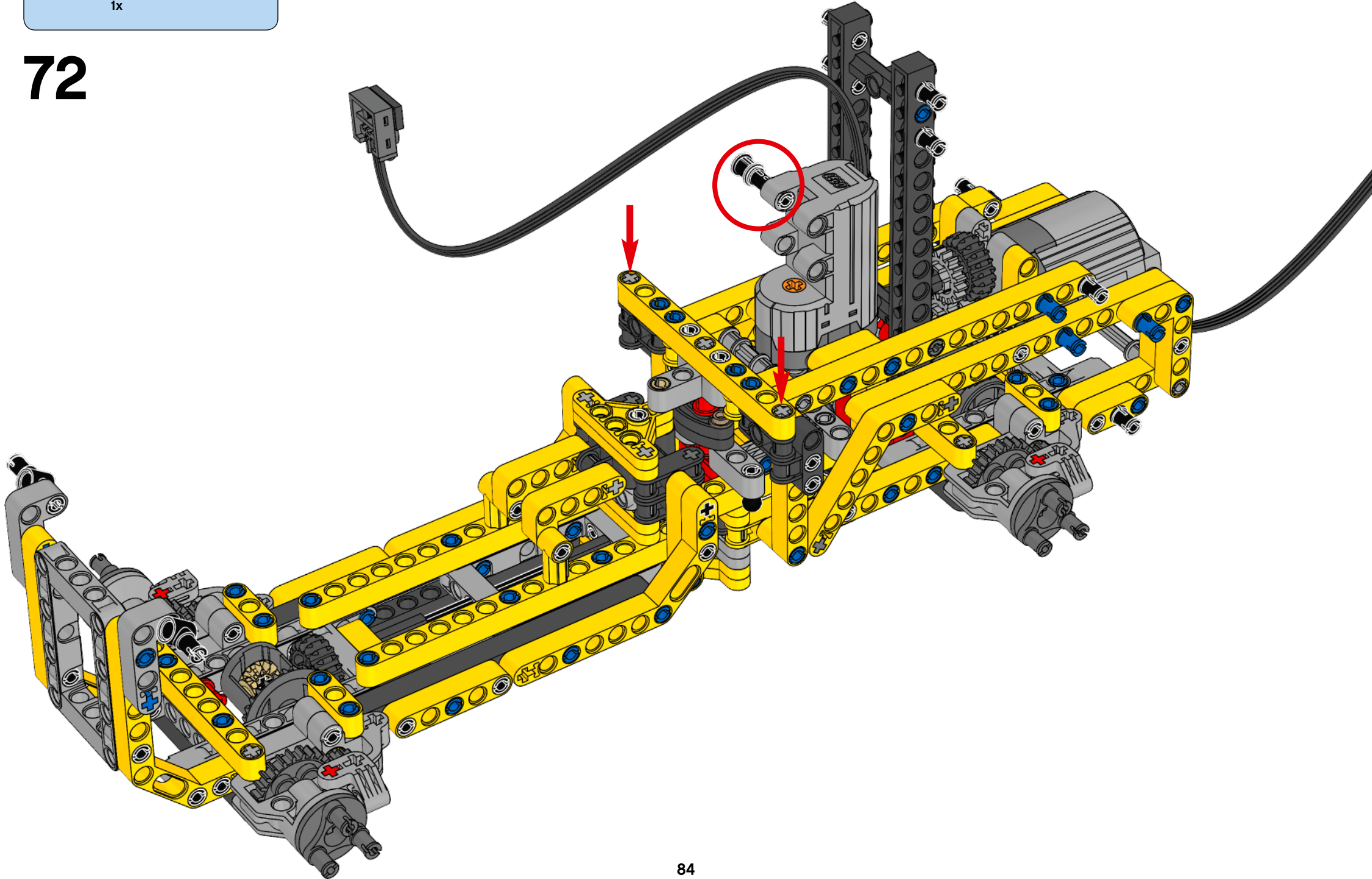

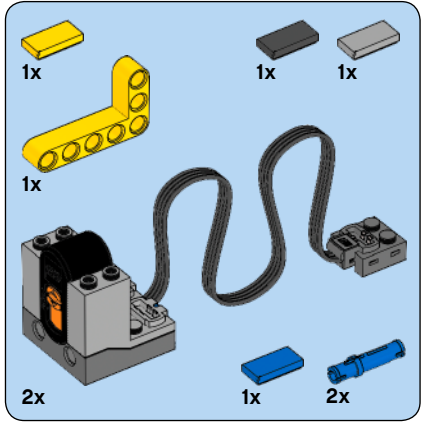
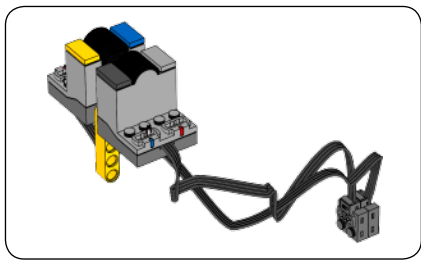

73

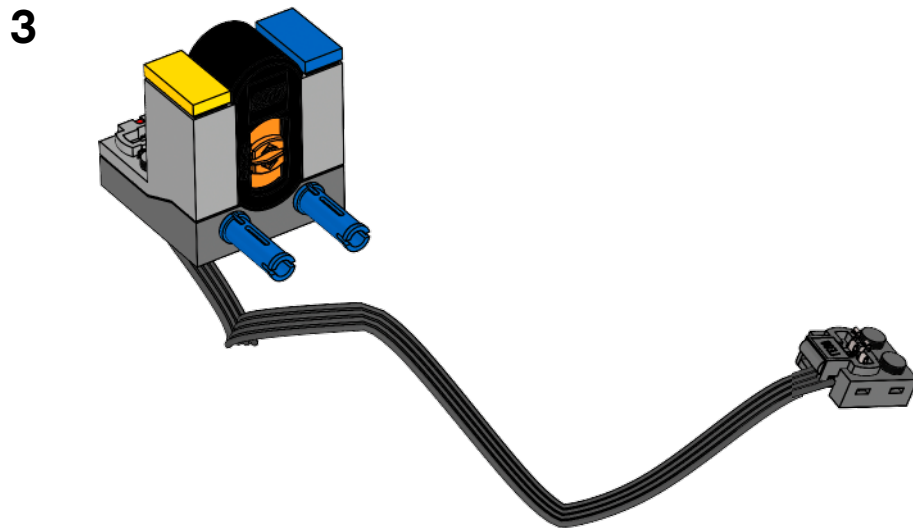
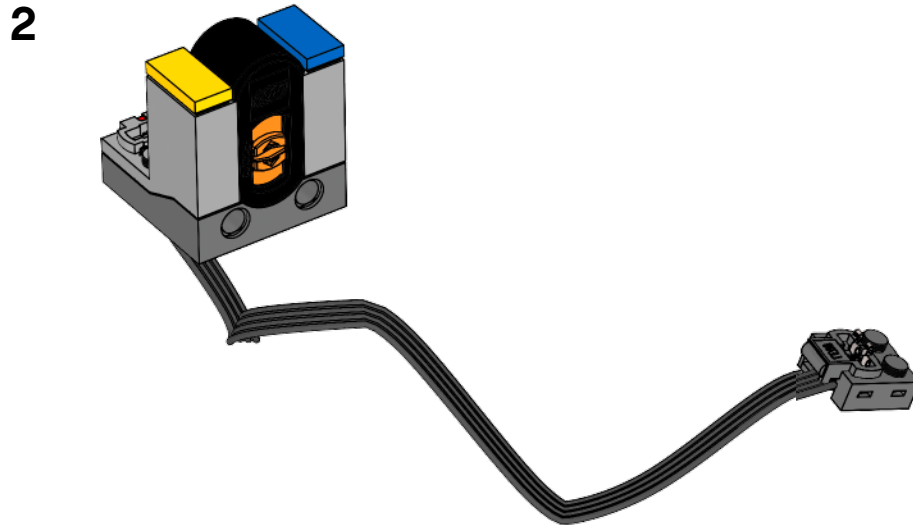
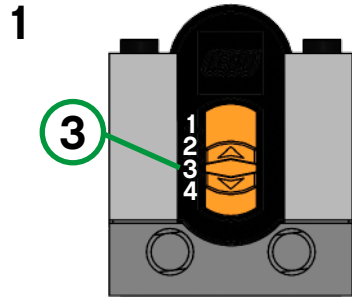

4

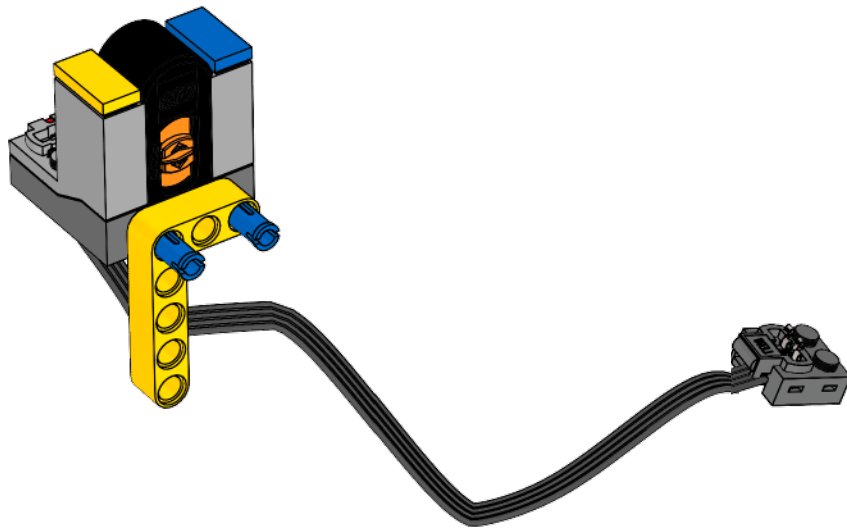

5

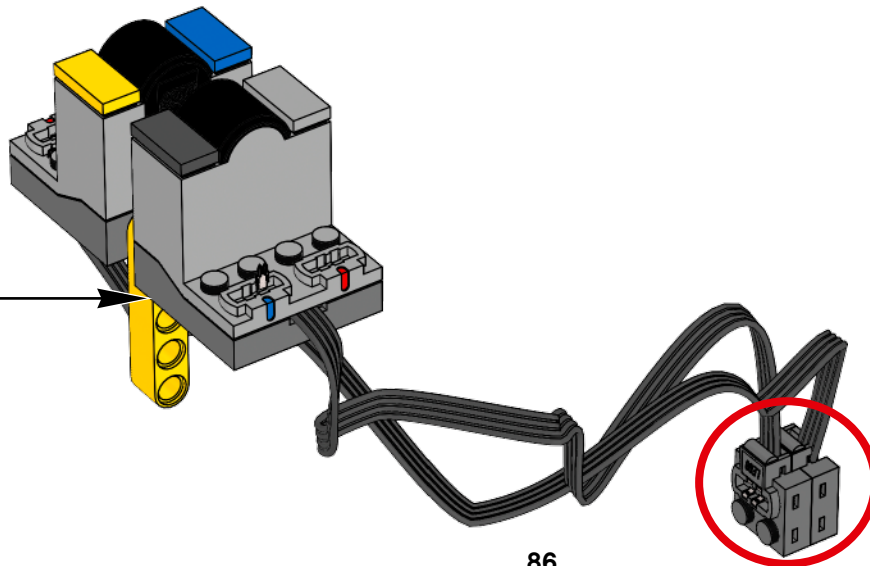
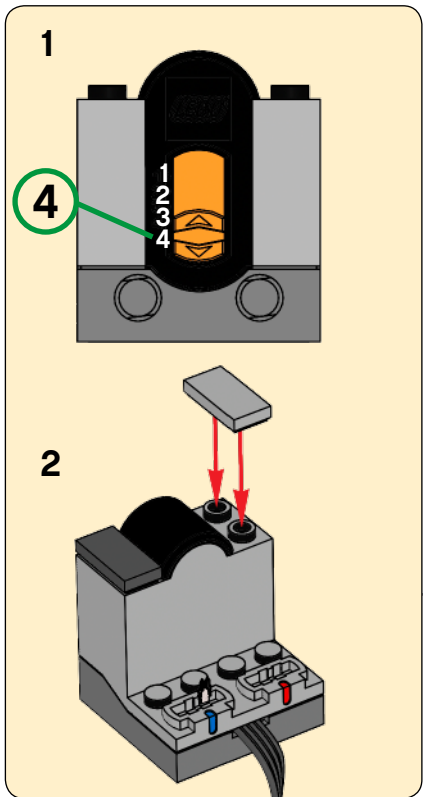

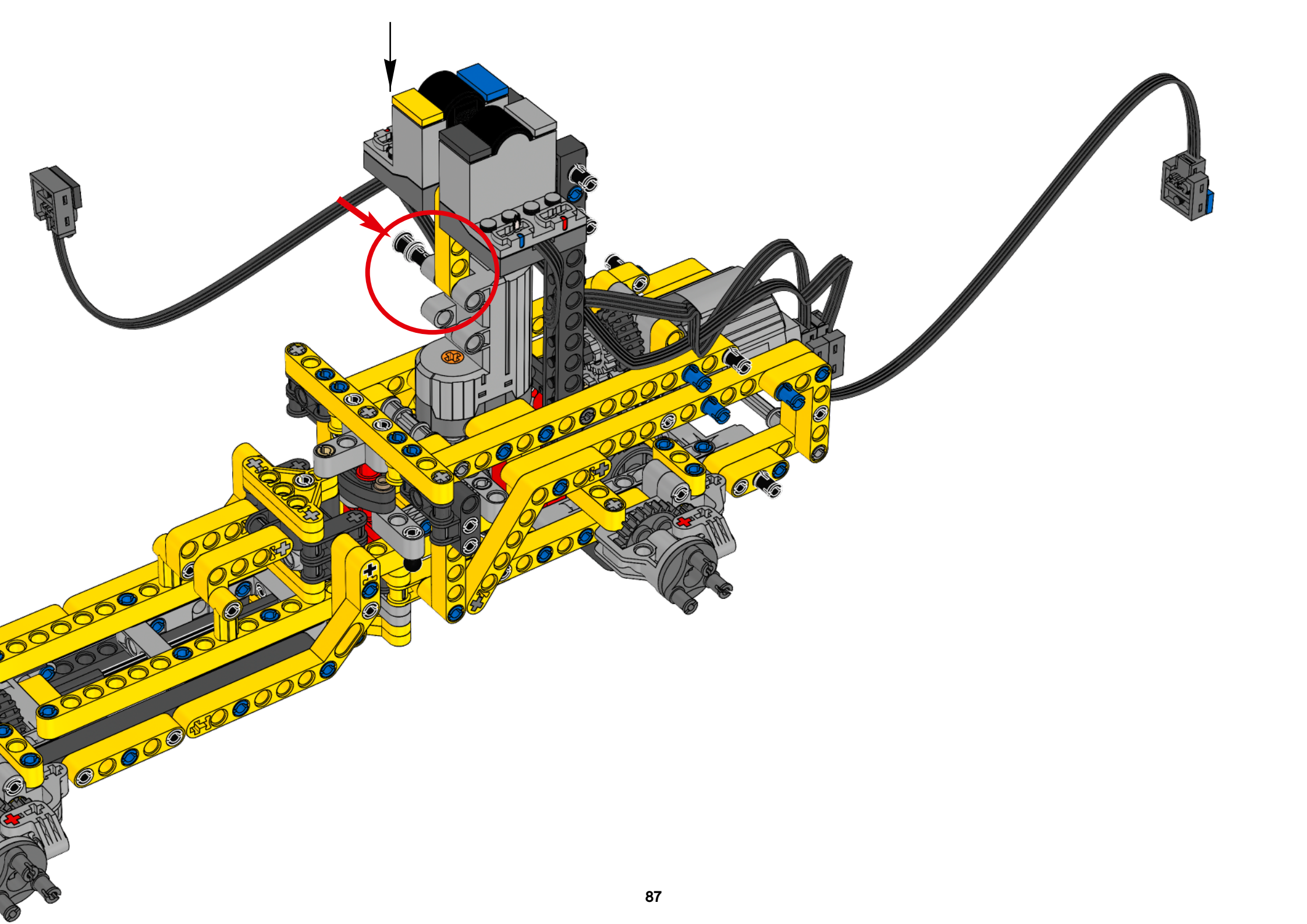

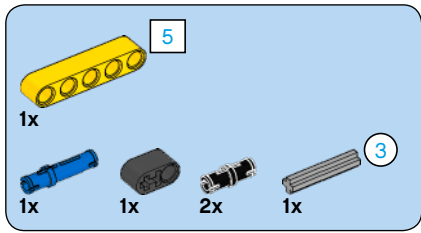

74

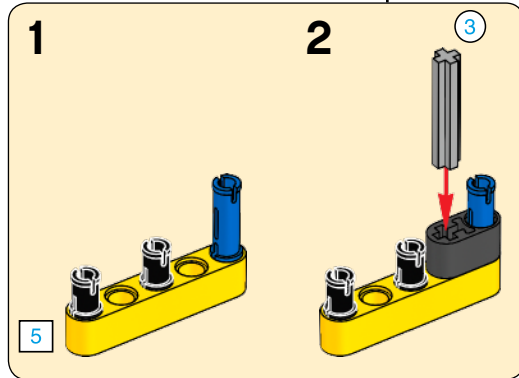
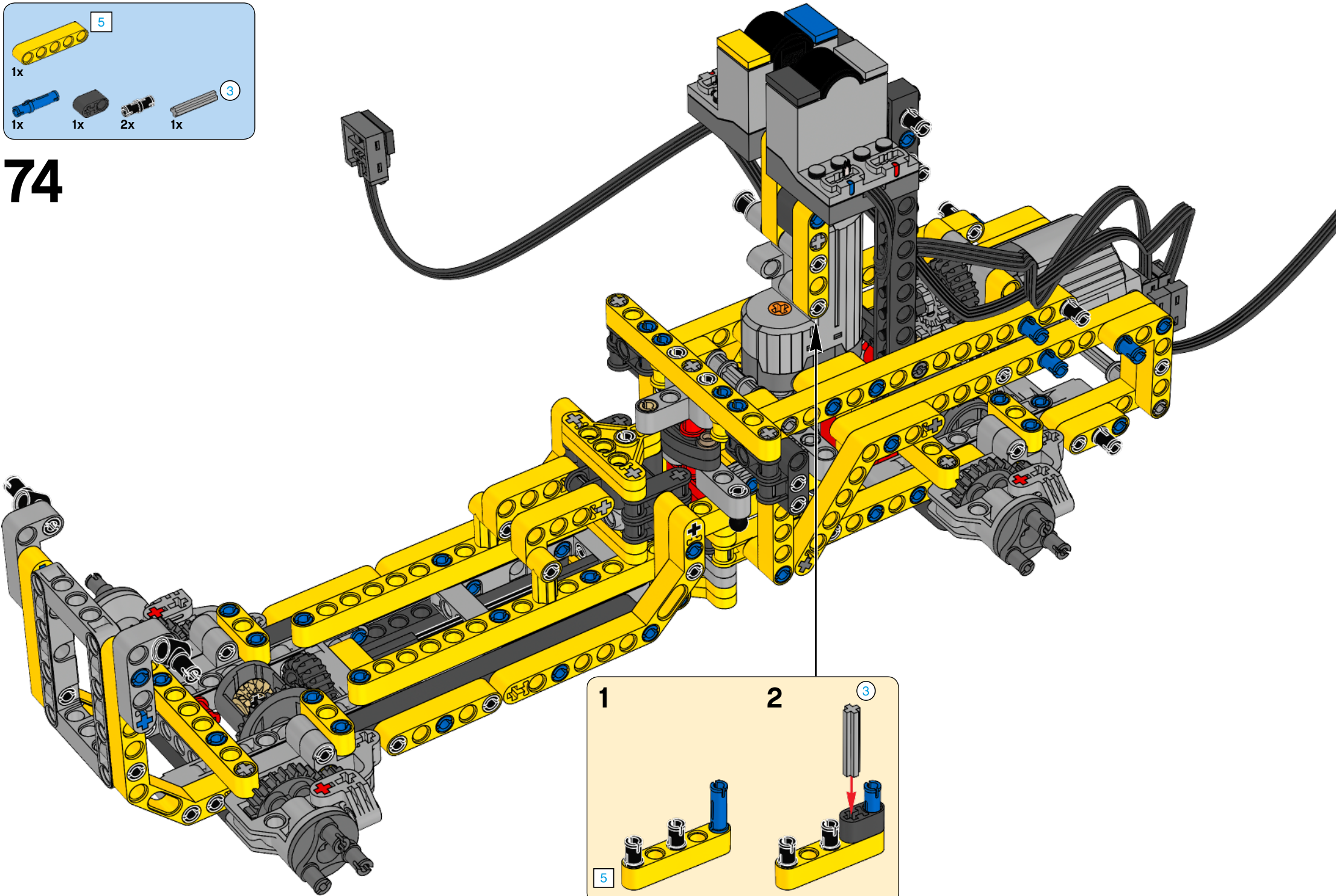

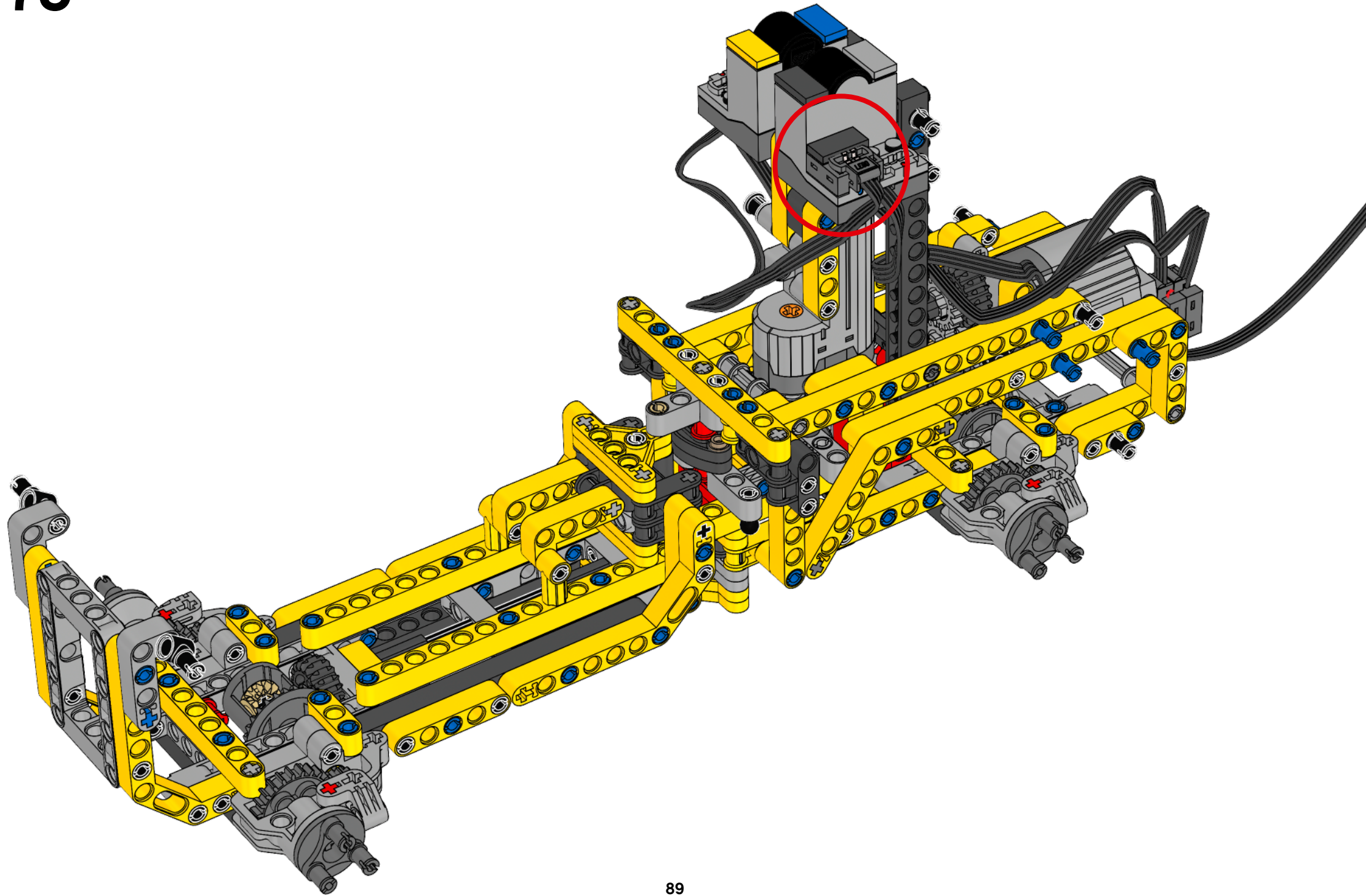

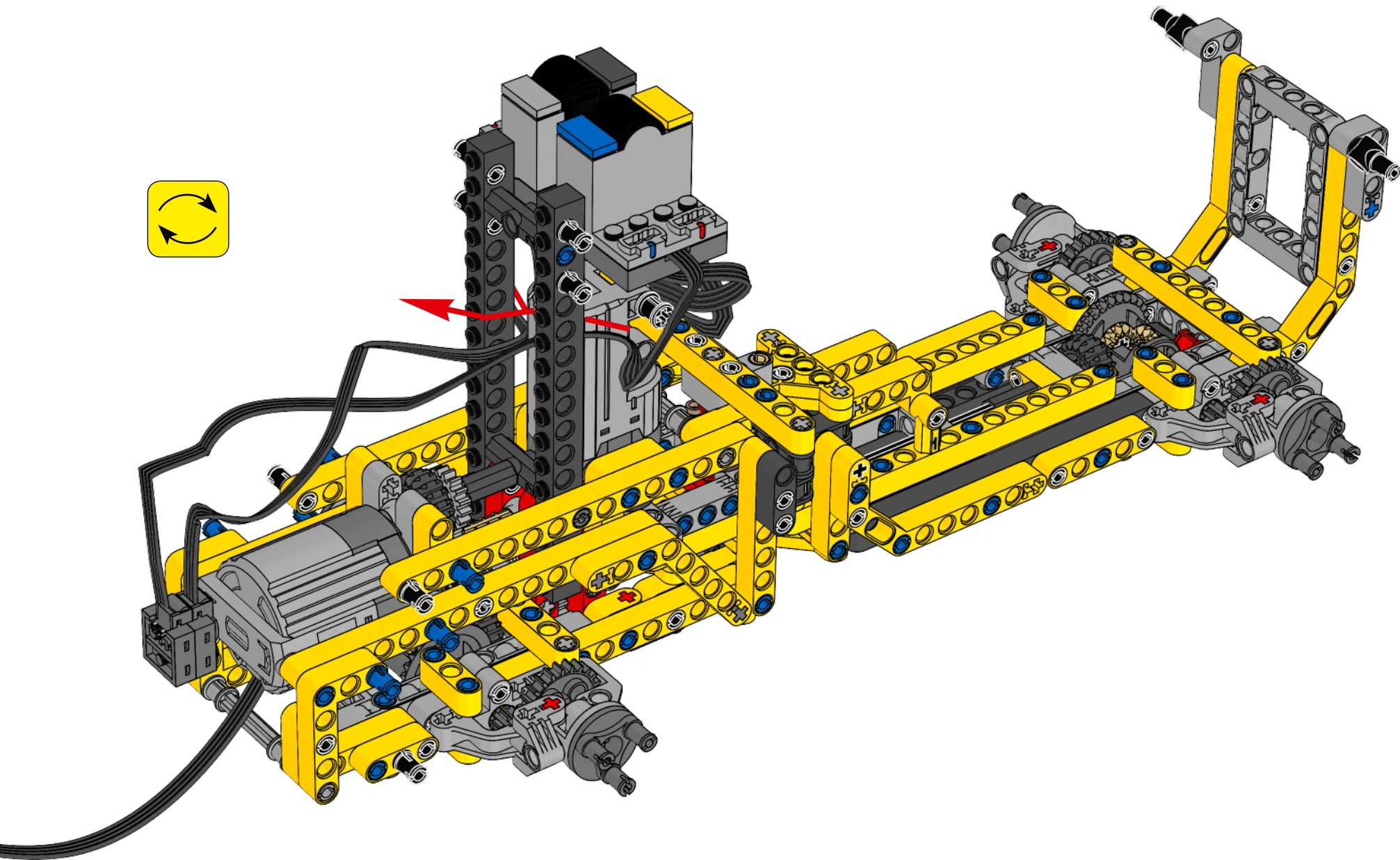

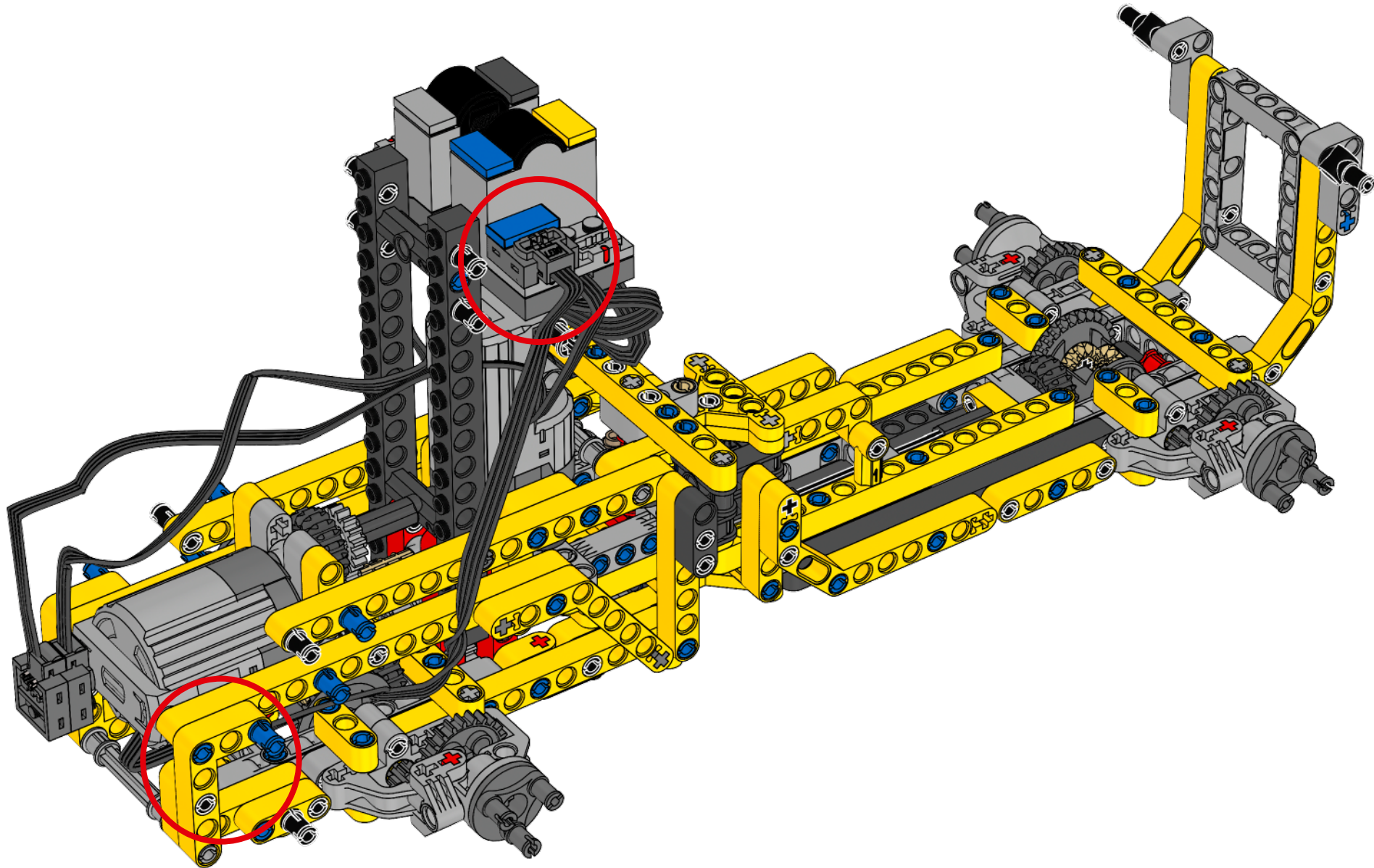

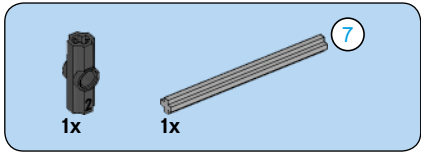
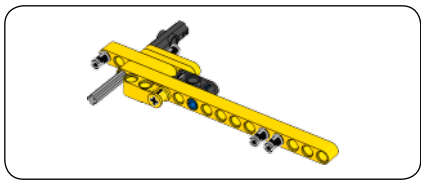

1

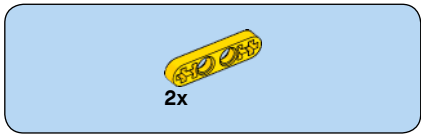
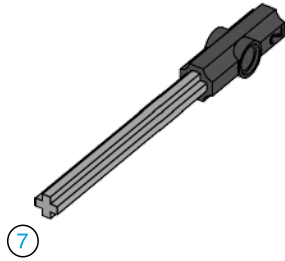

2

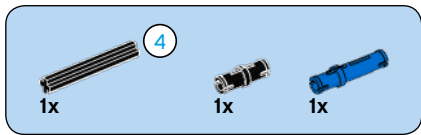
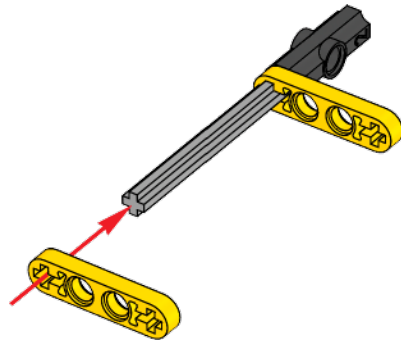

3

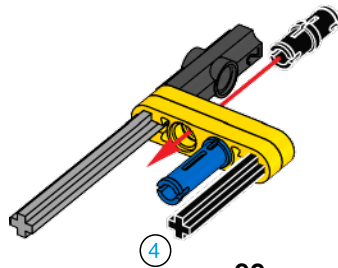

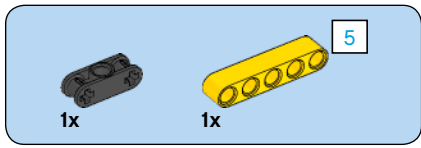

4

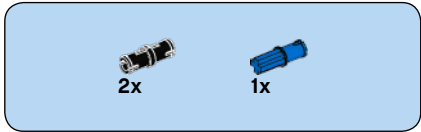
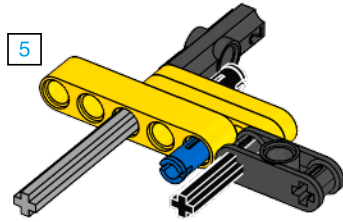

5

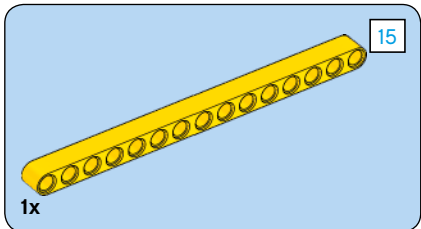
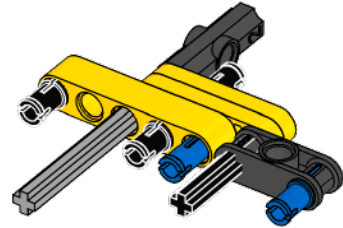

6

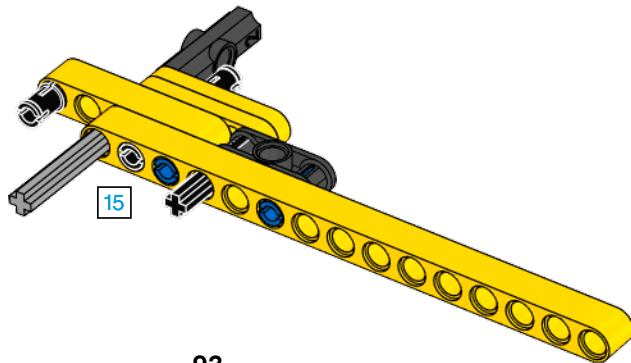

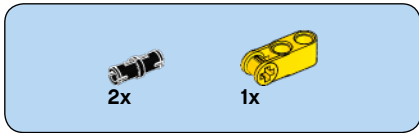

7

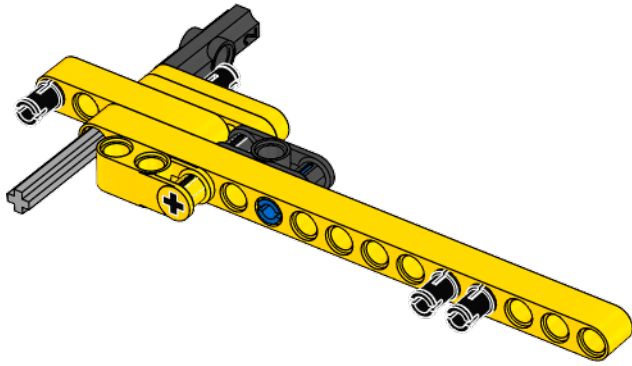

78

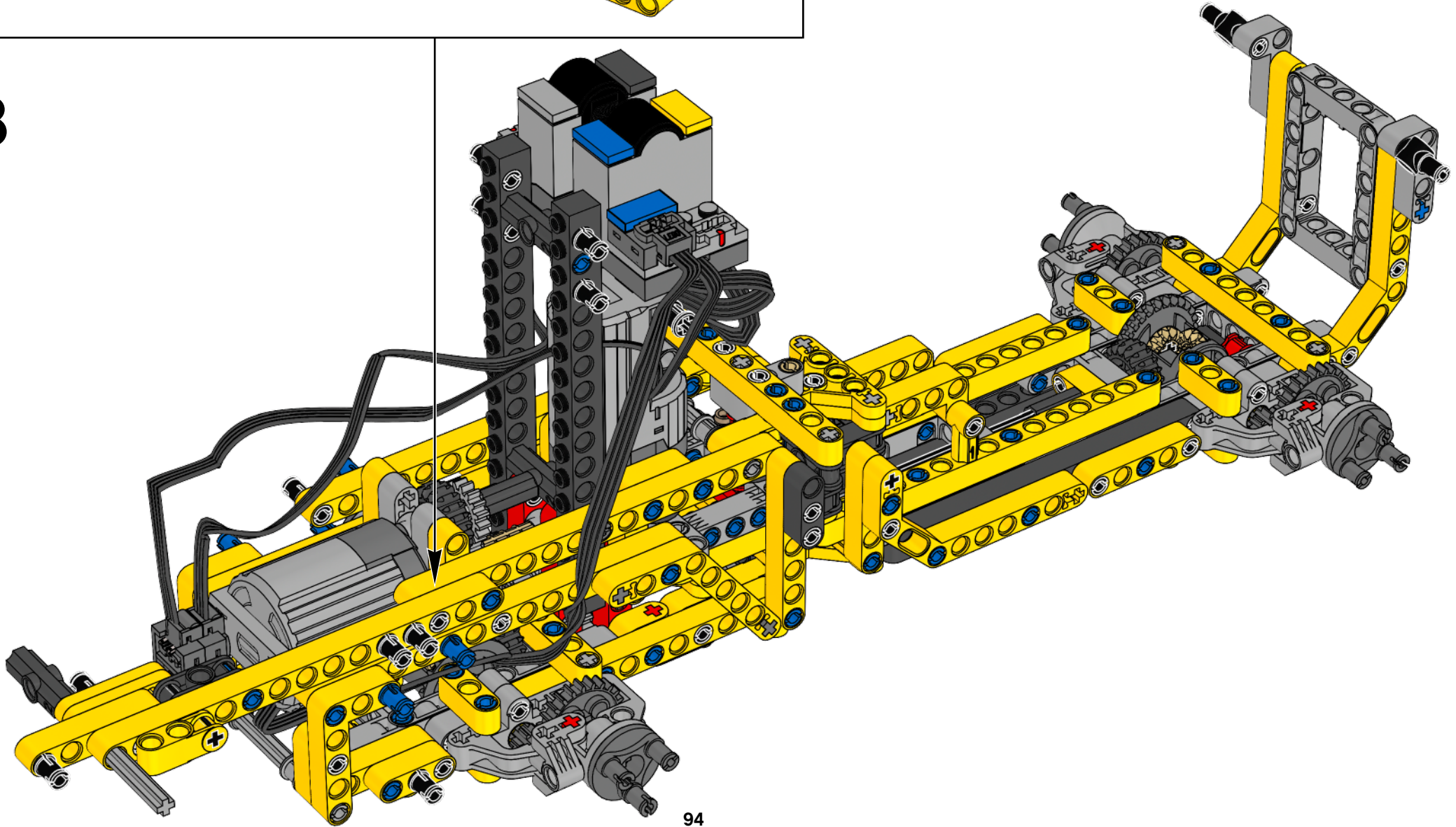

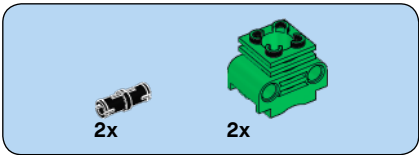
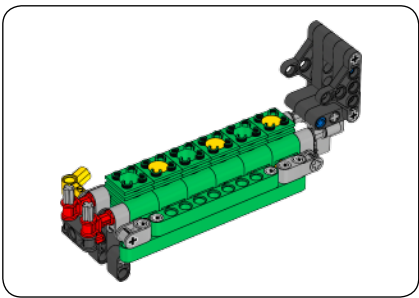

1

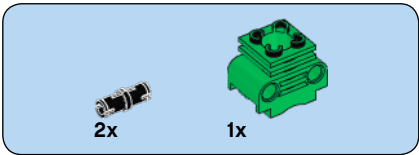
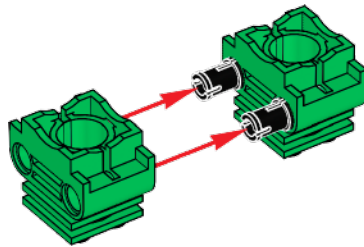

2

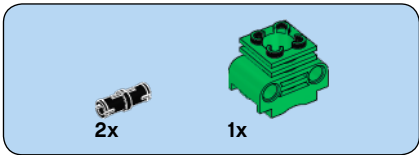
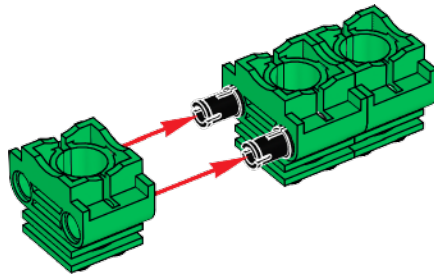

3

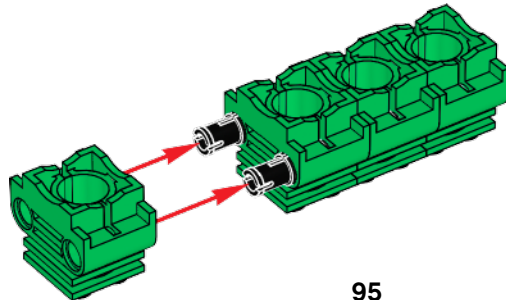

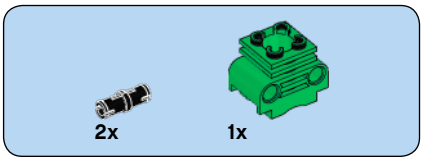

4

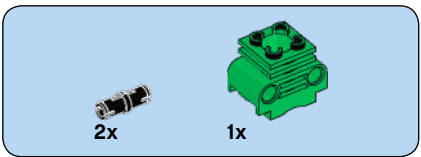
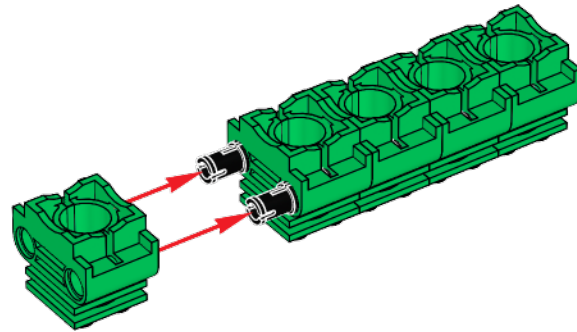

5

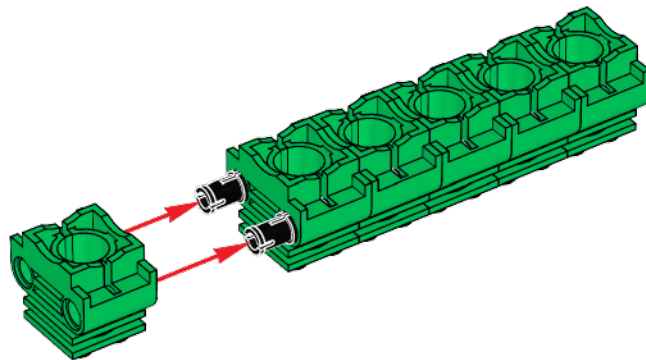

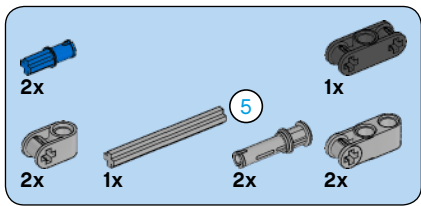

6

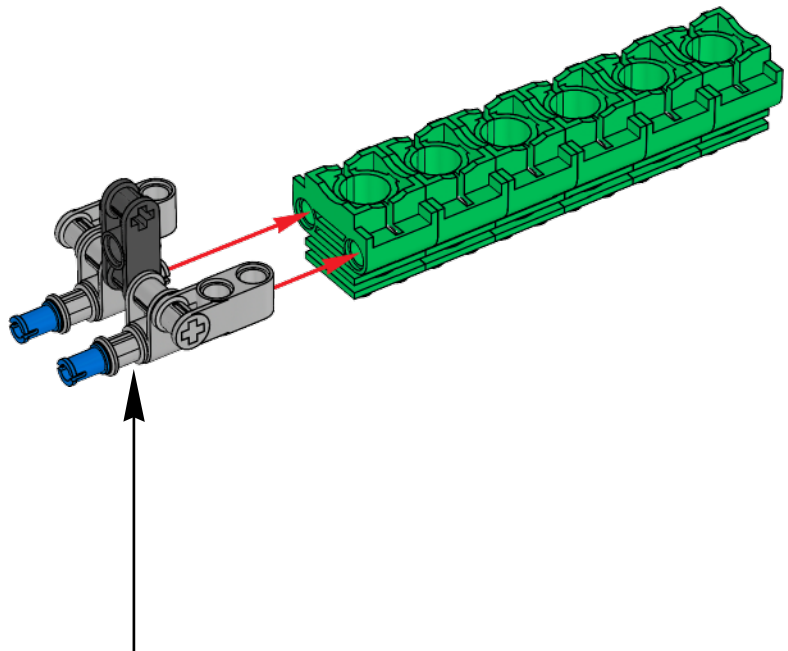
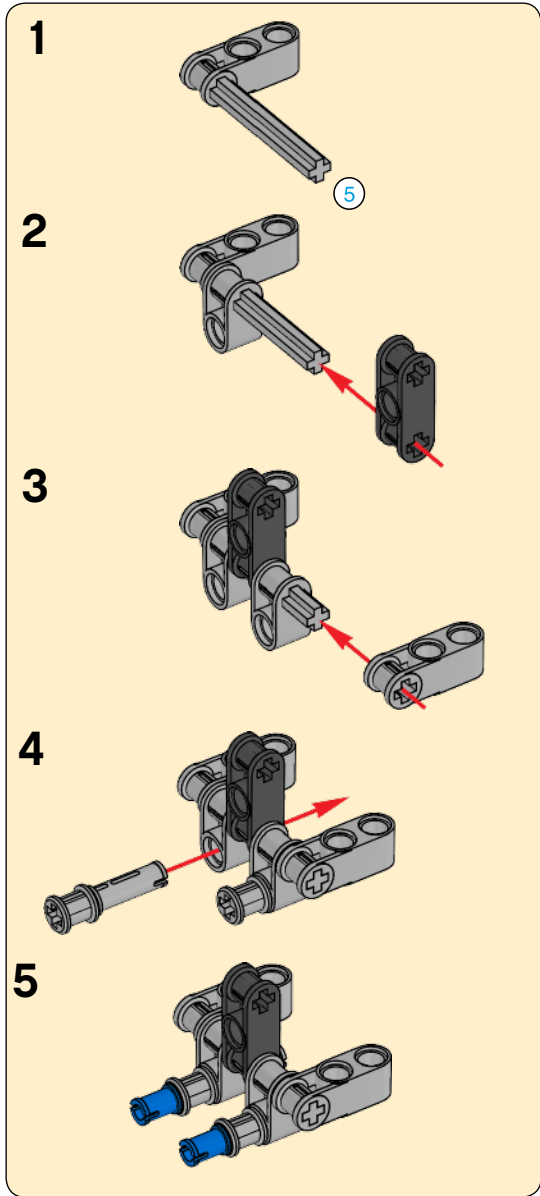

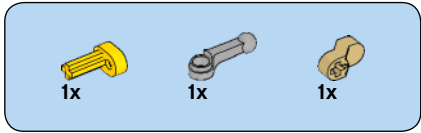
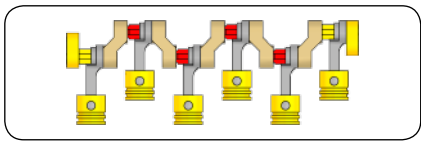

1

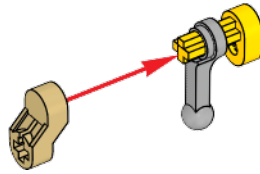

2

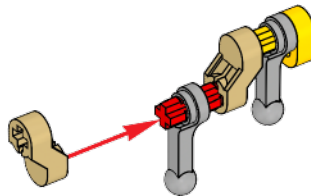

3

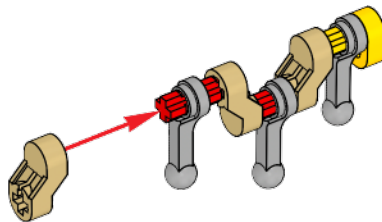

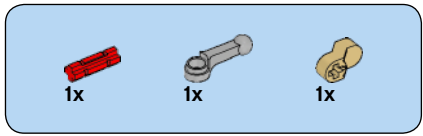

4

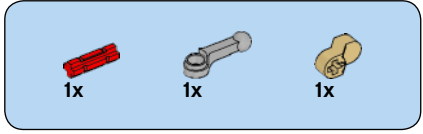
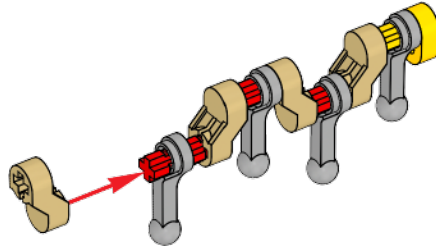

5

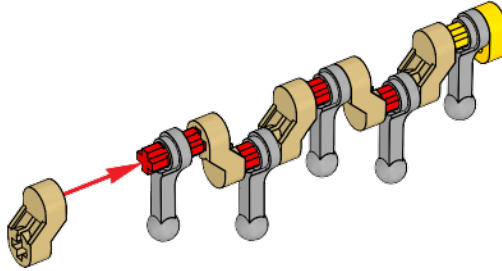

6

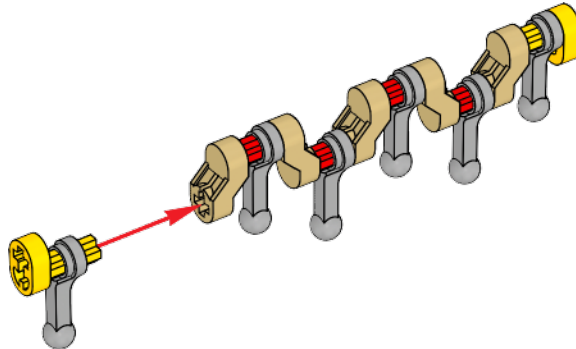

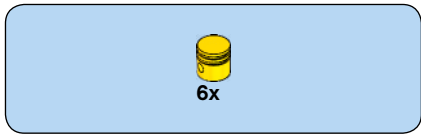

7

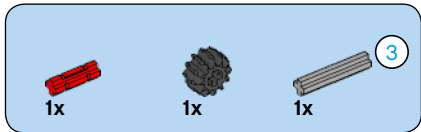
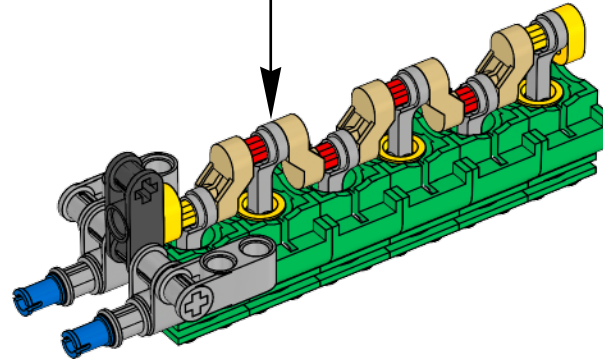
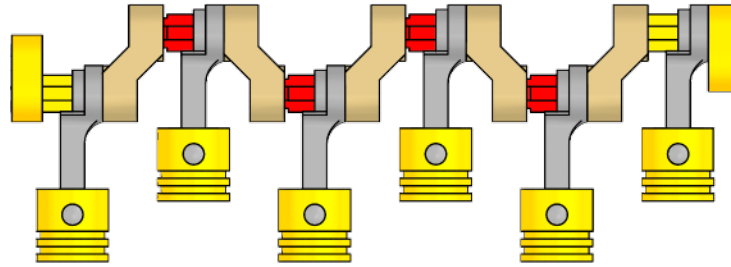

8

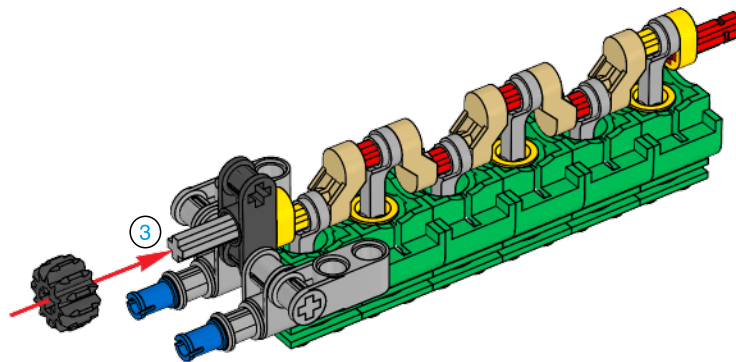

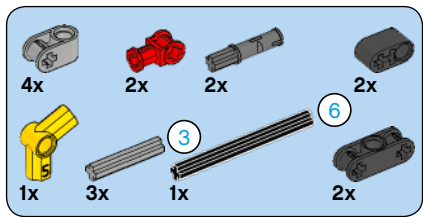

9

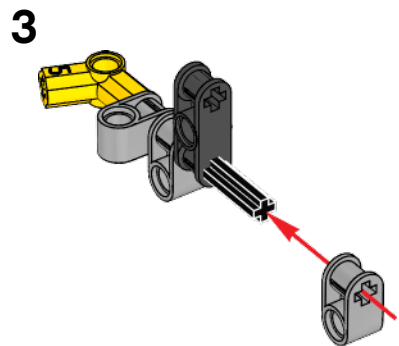
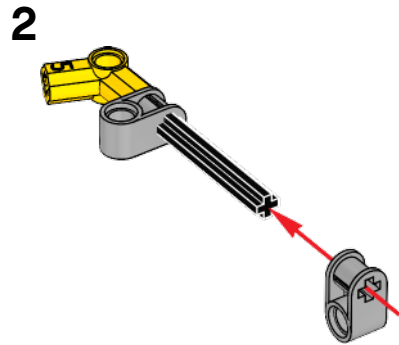

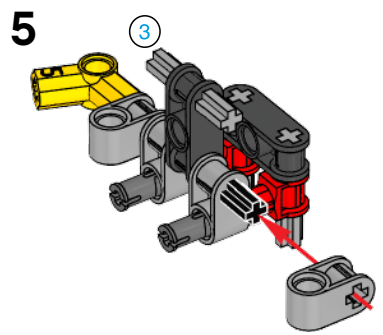
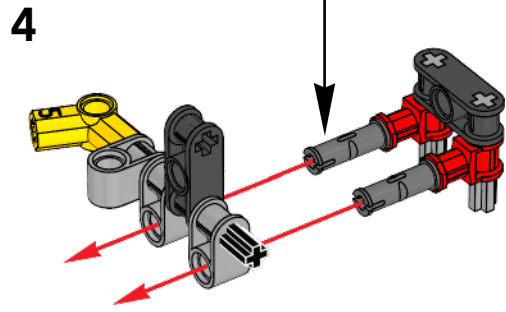
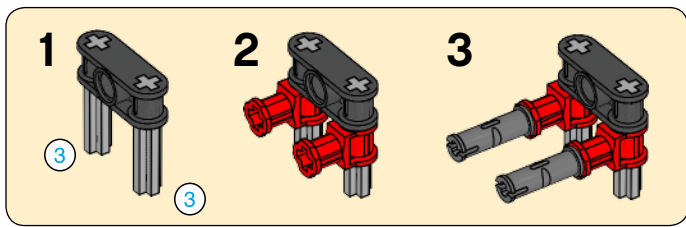

6

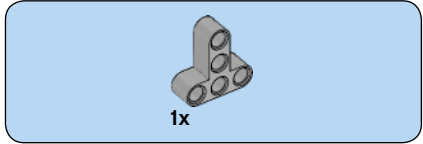
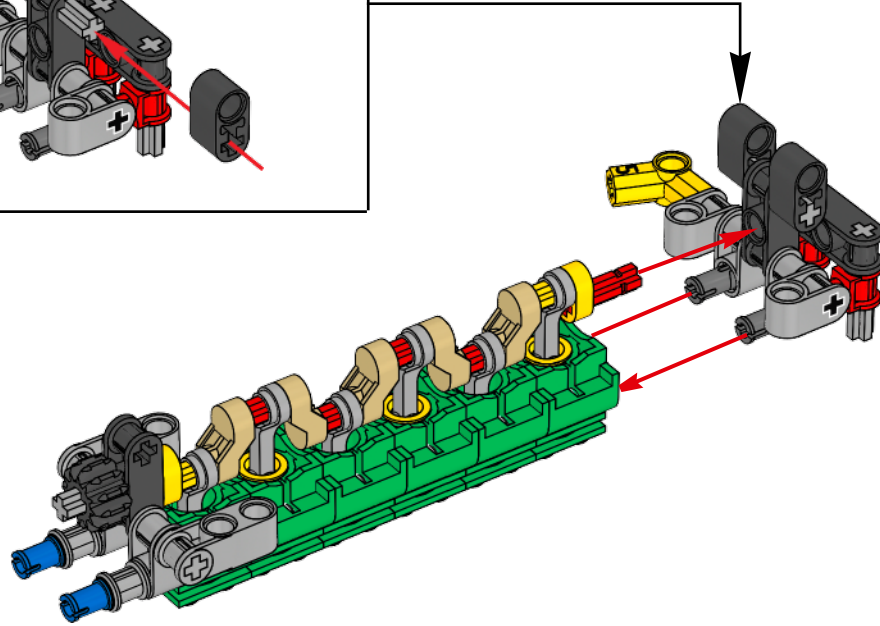
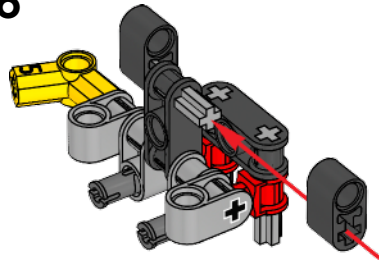

10

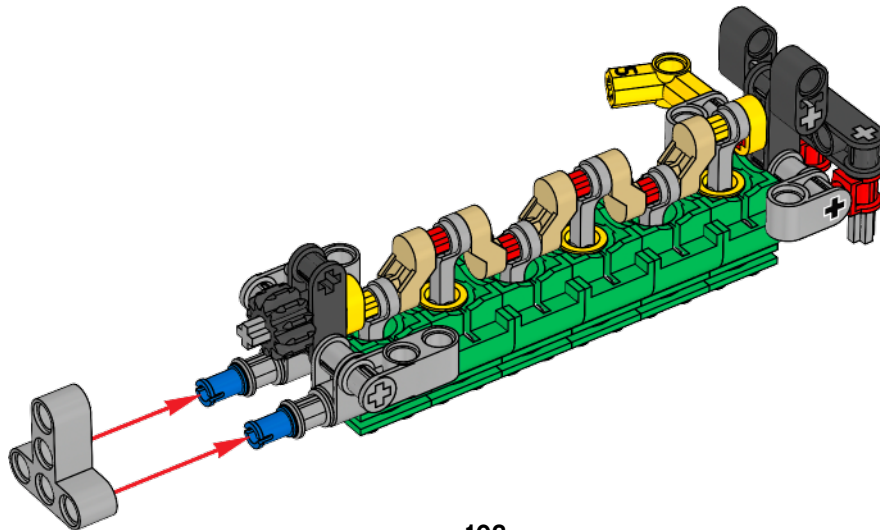

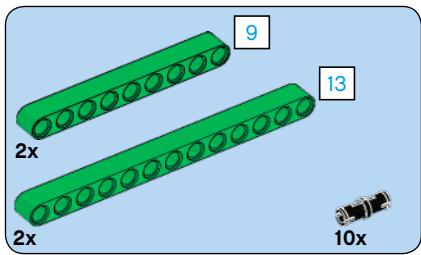

11

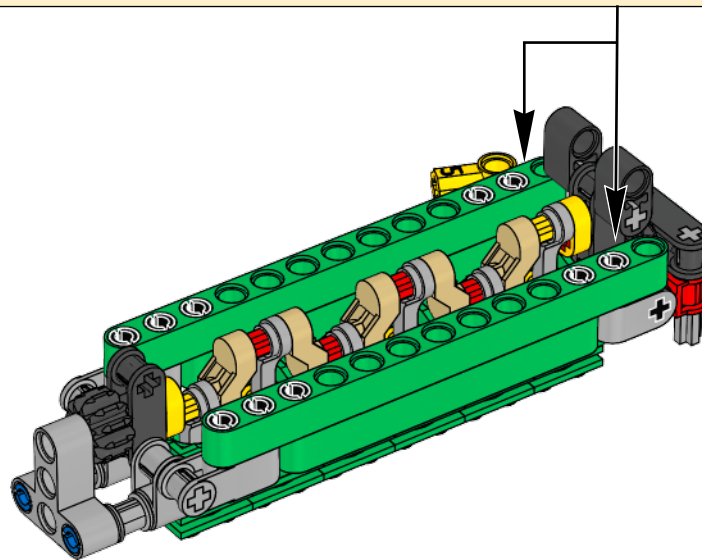
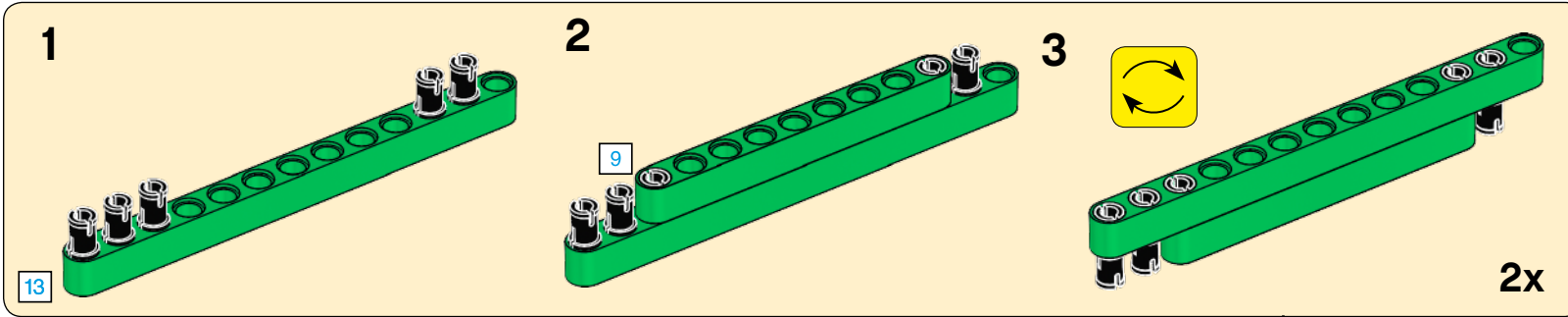

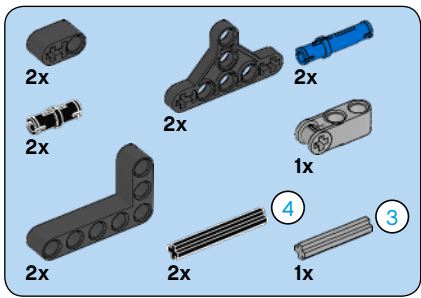

12

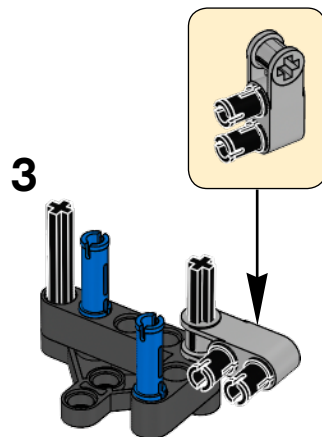
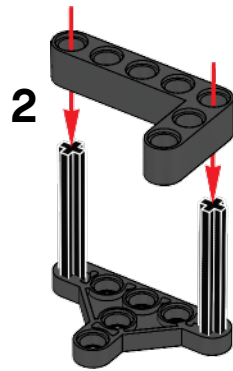
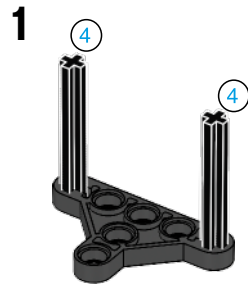

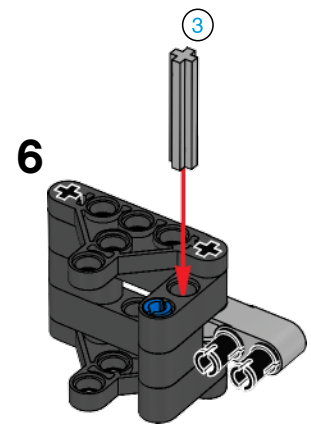
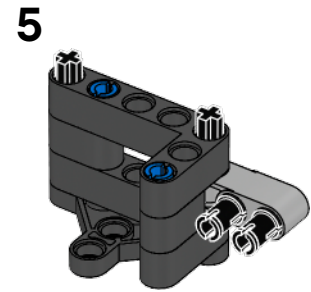
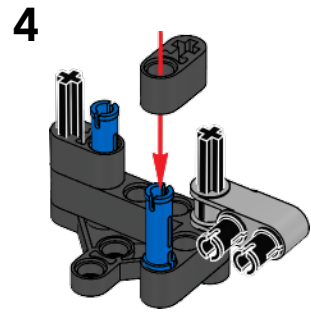

7

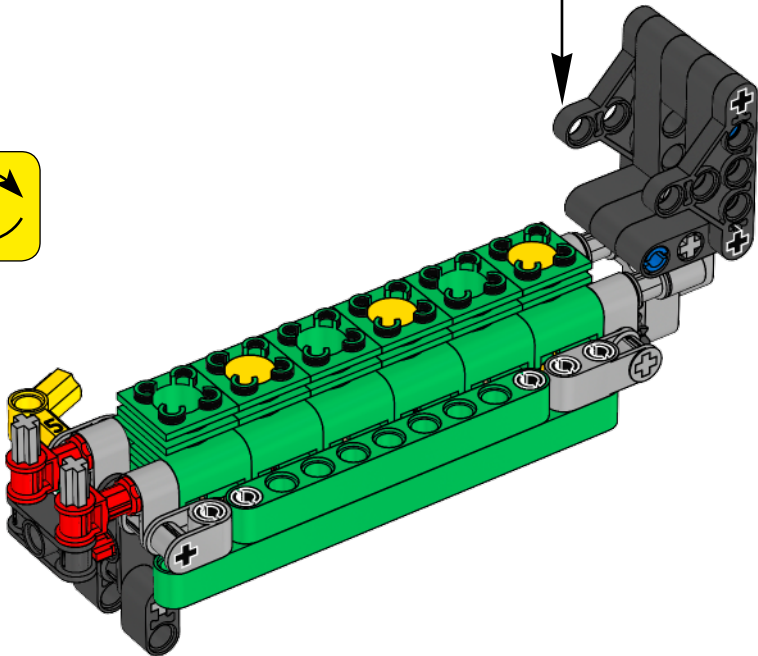
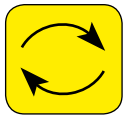
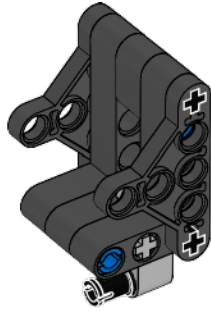
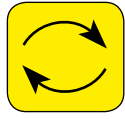

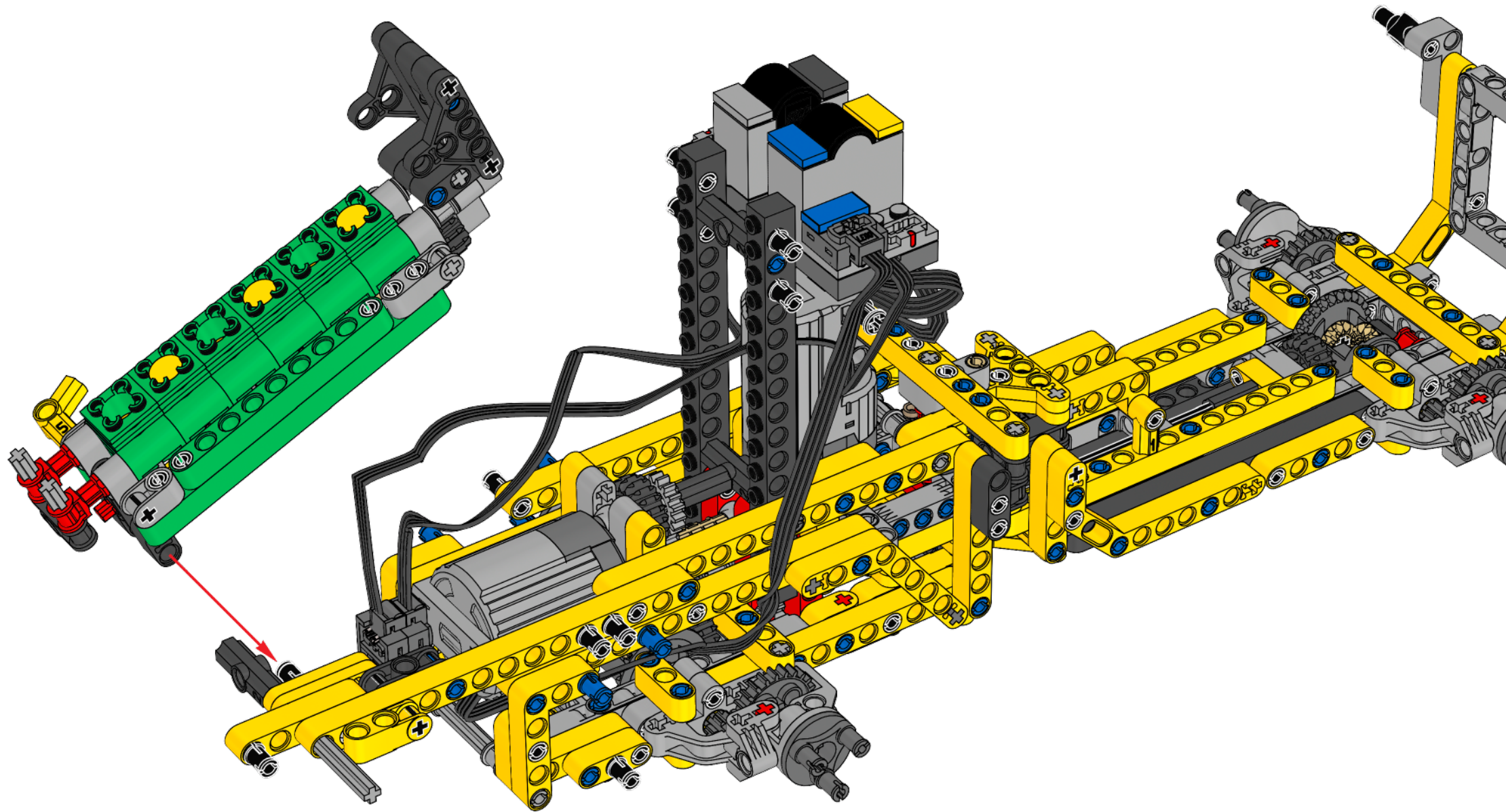

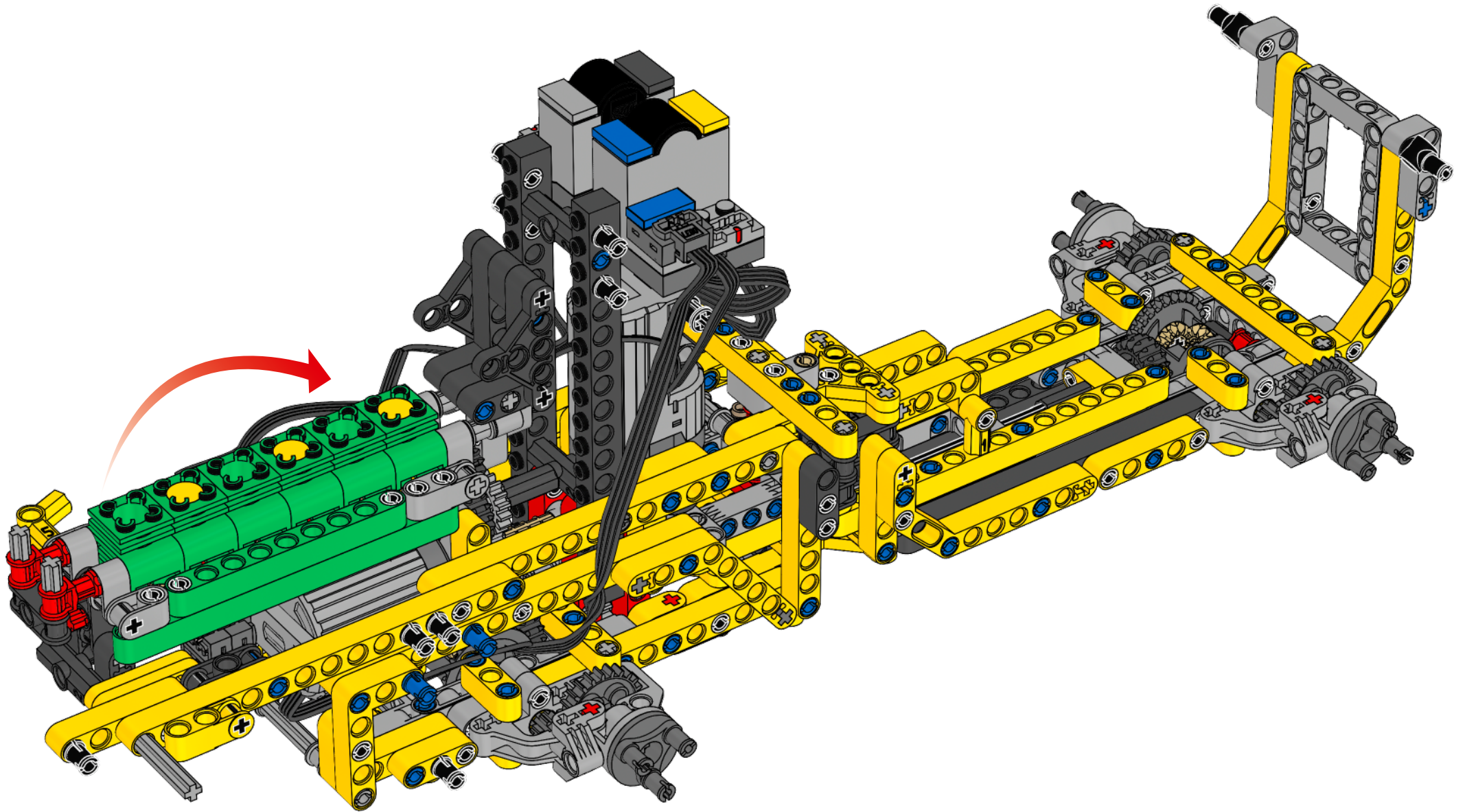

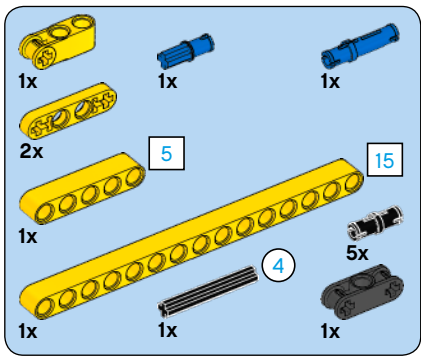

81

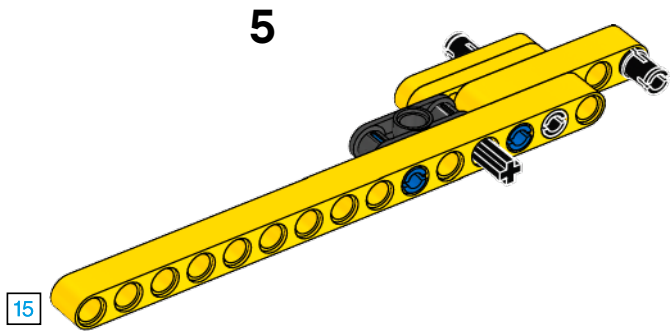
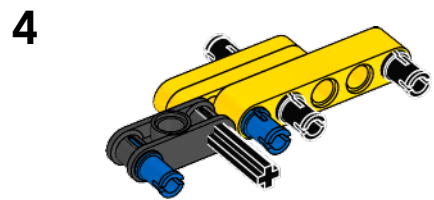
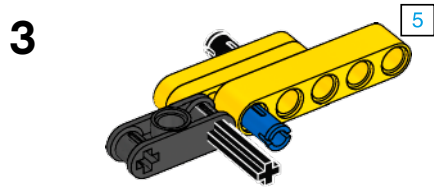
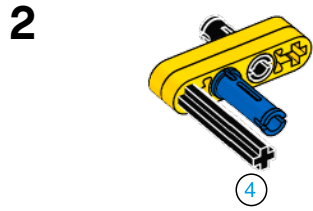
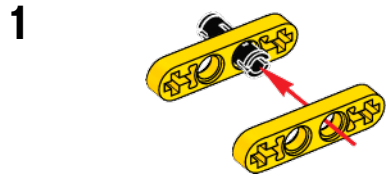

6

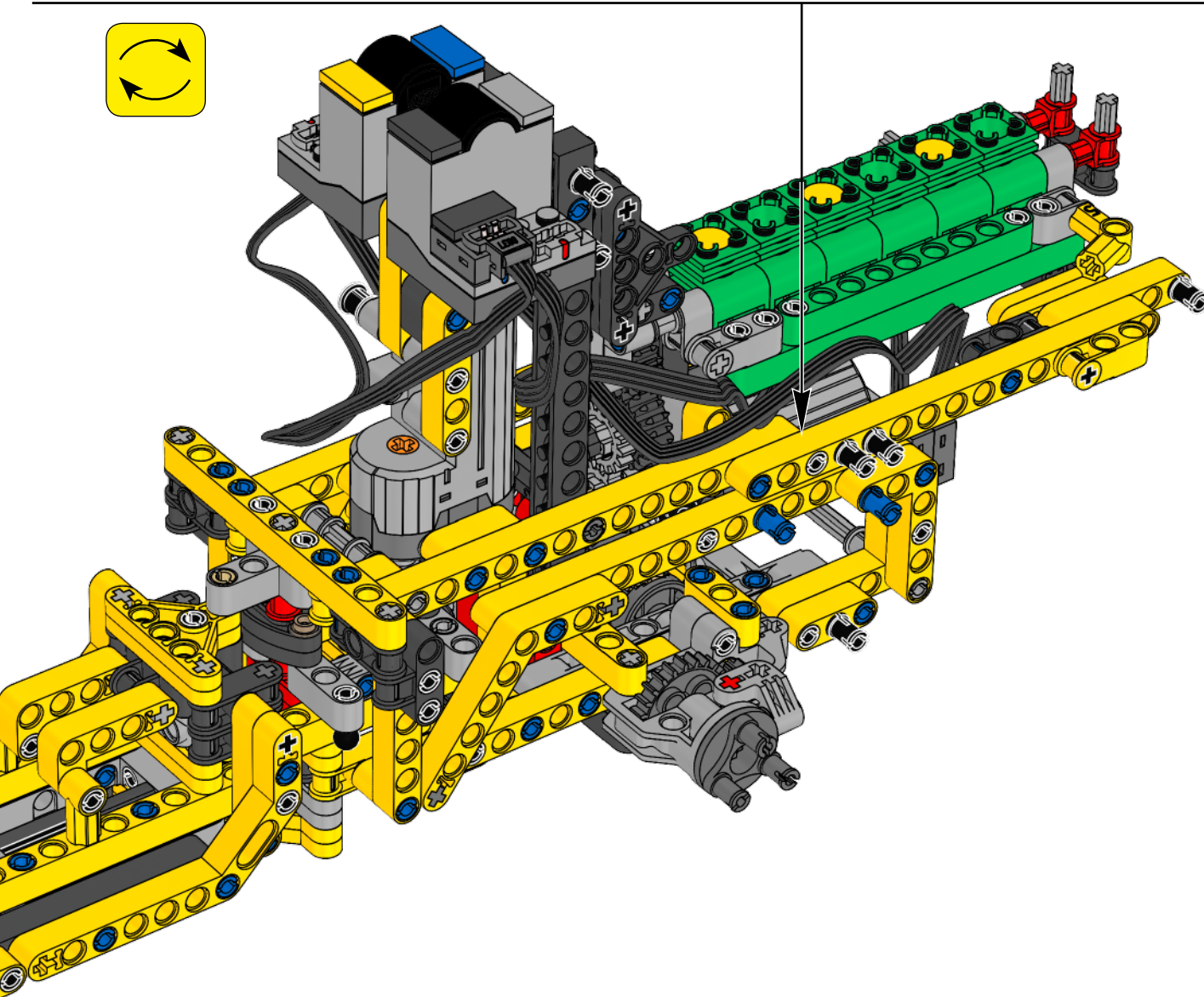
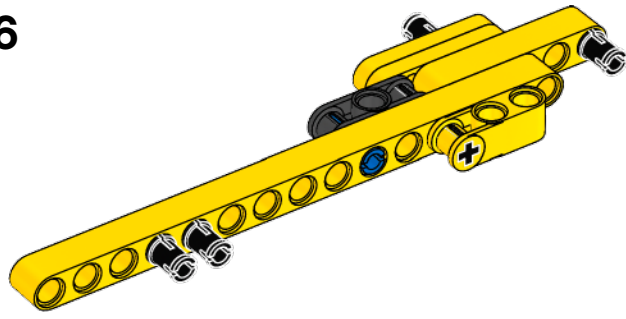

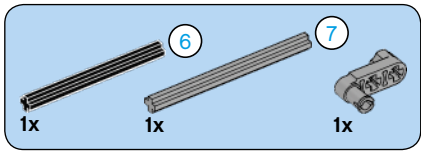

82

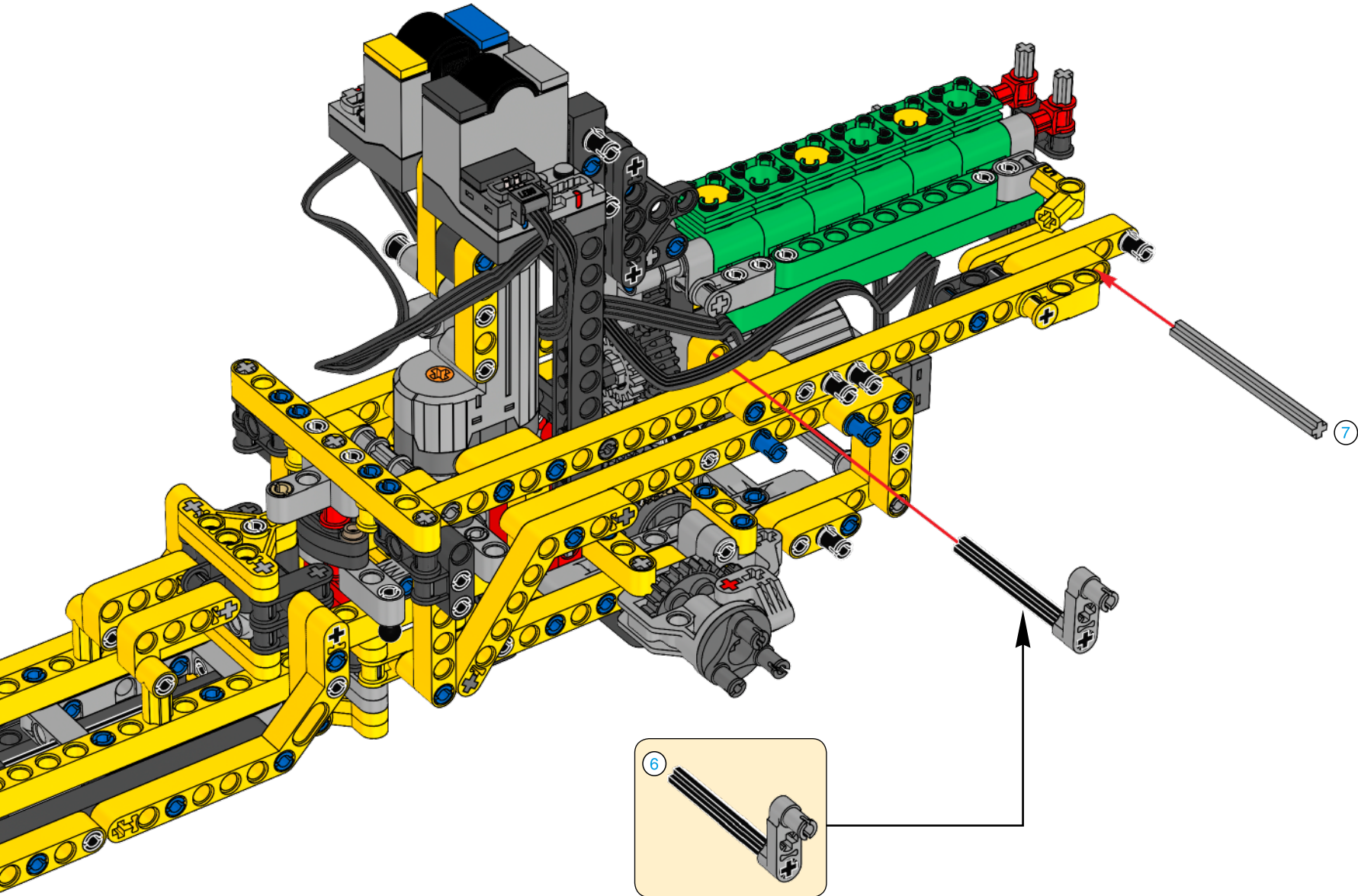

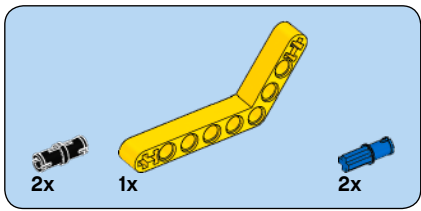

83

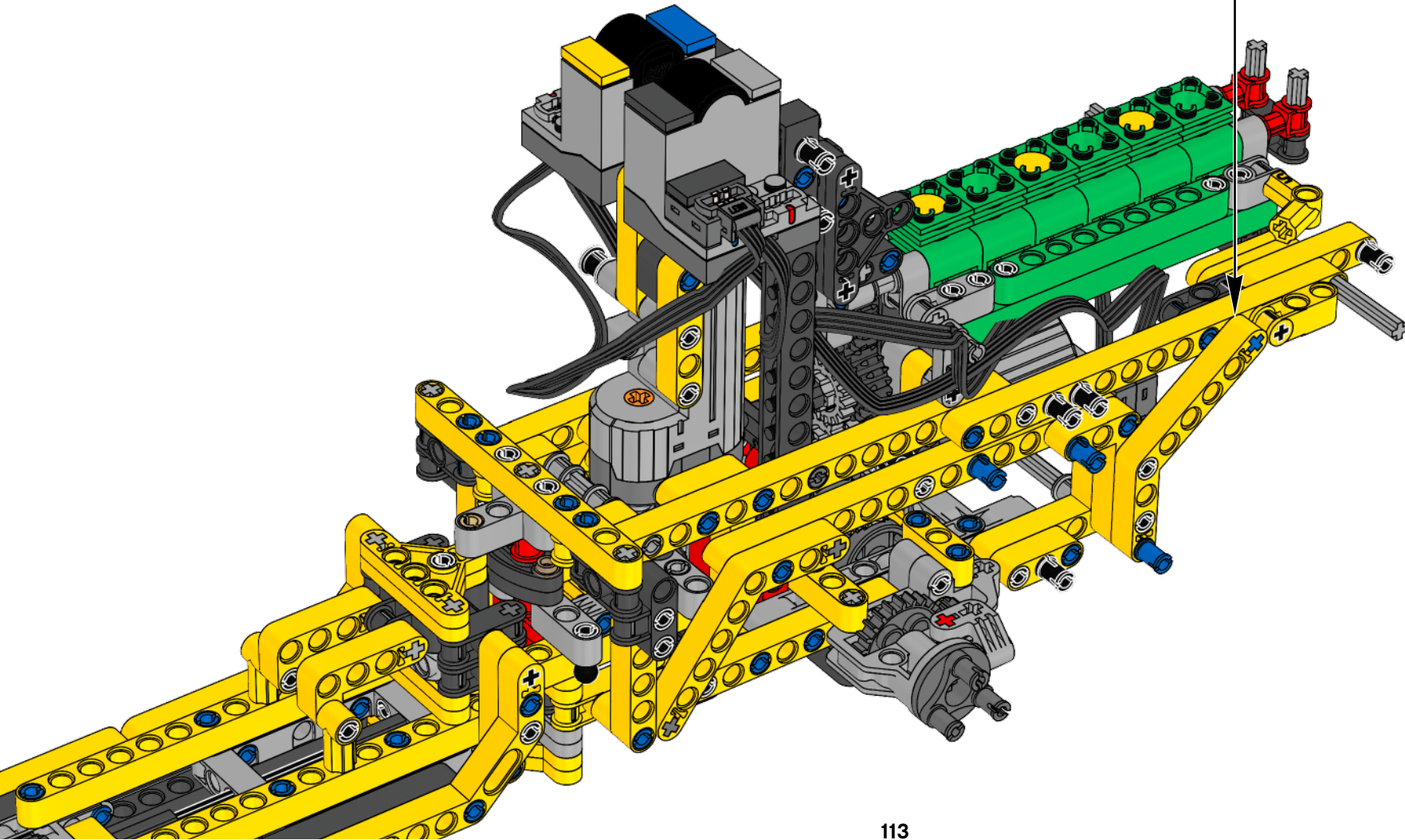
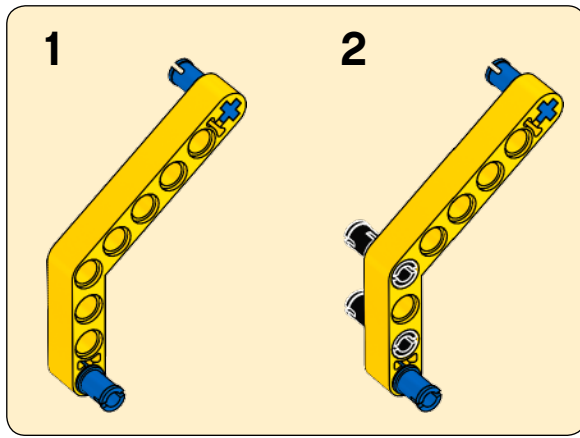

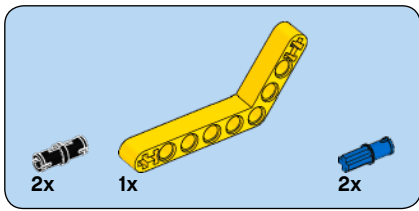

84

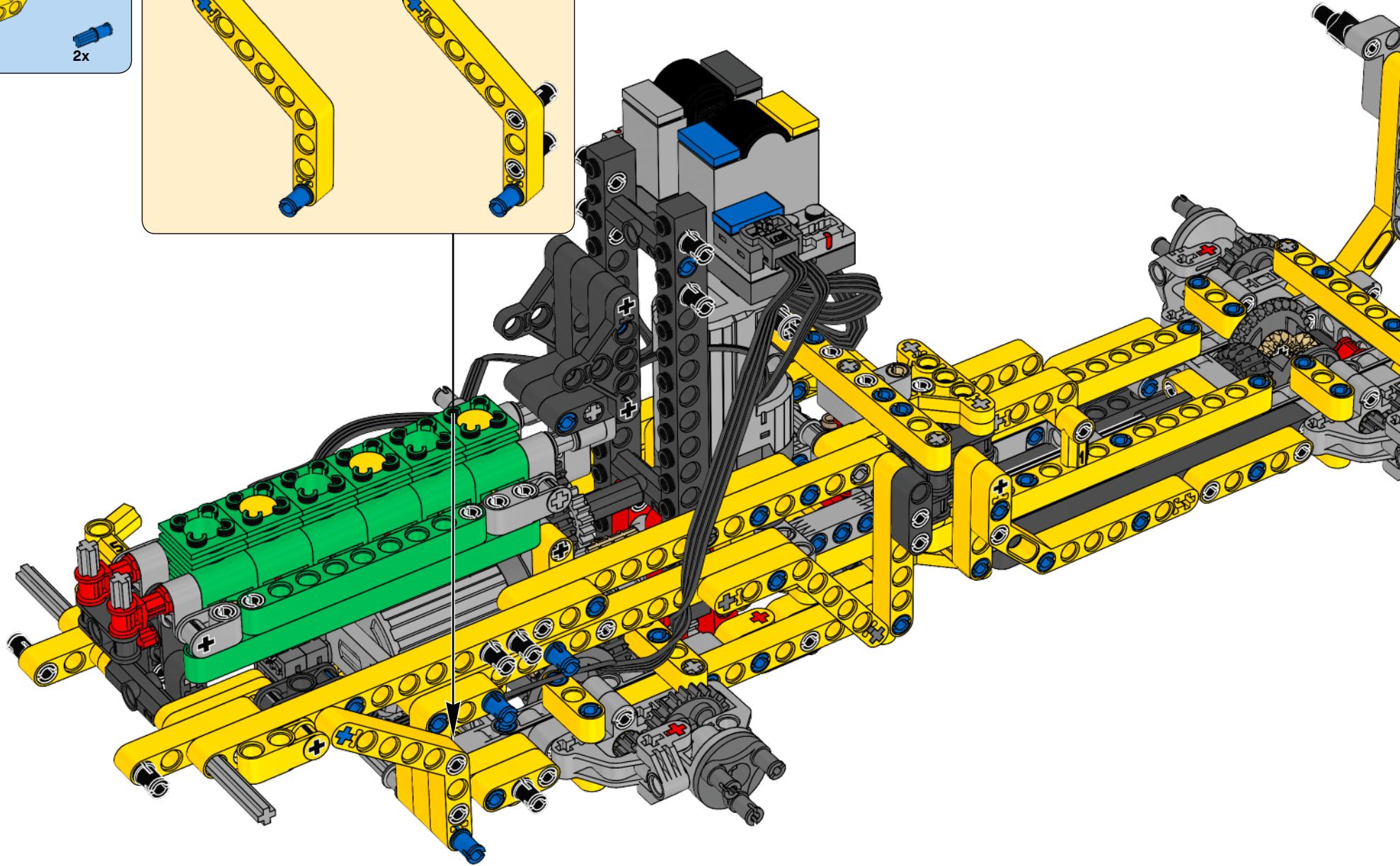
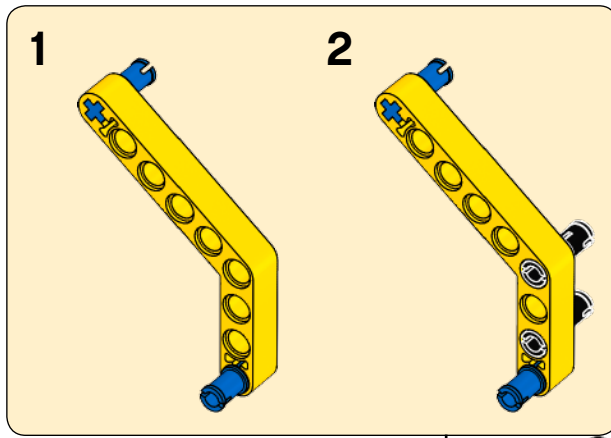

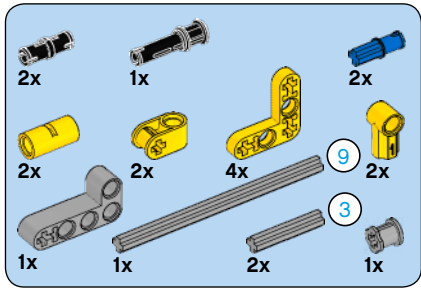
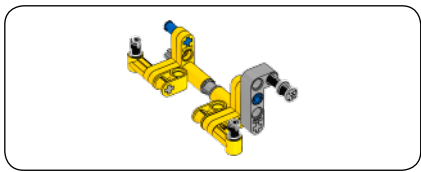

85

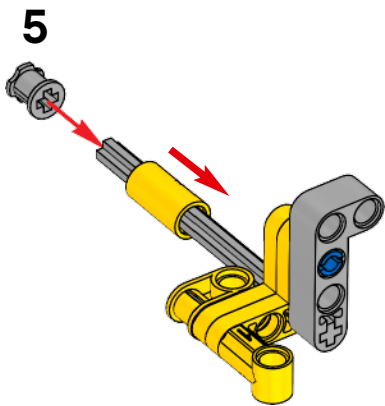
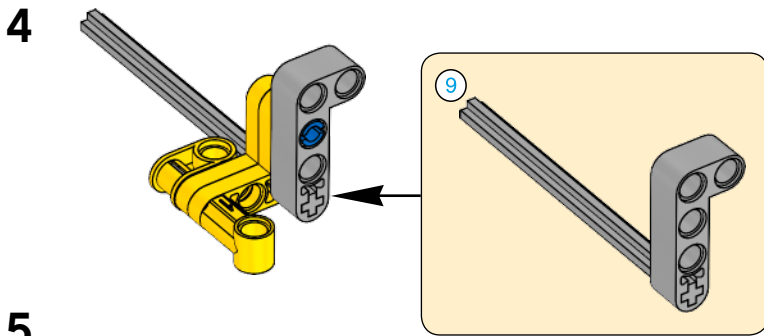
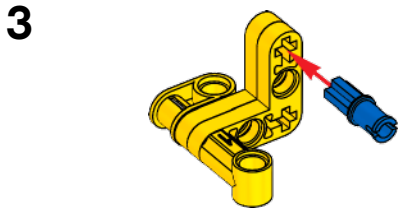
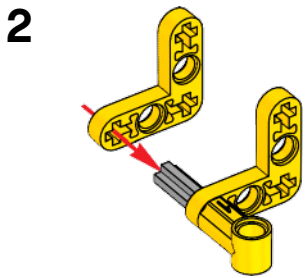
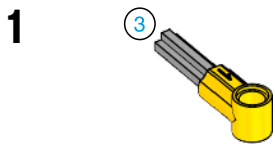

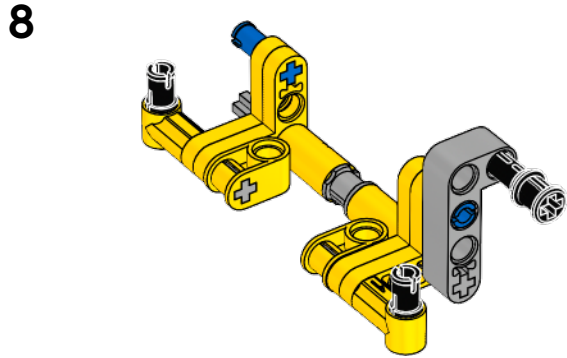
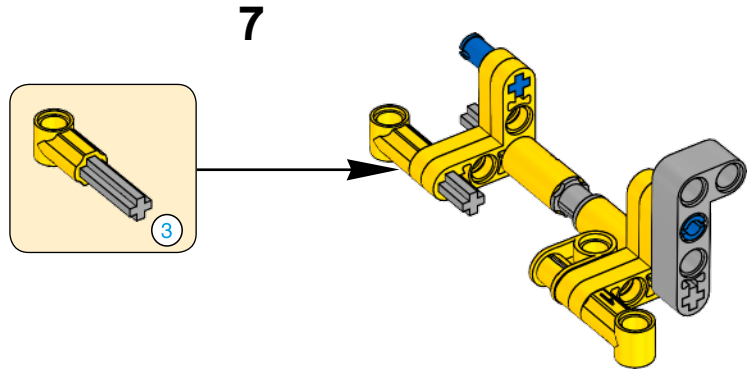
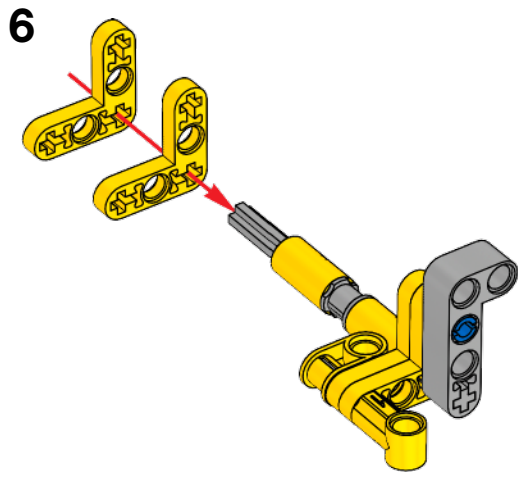

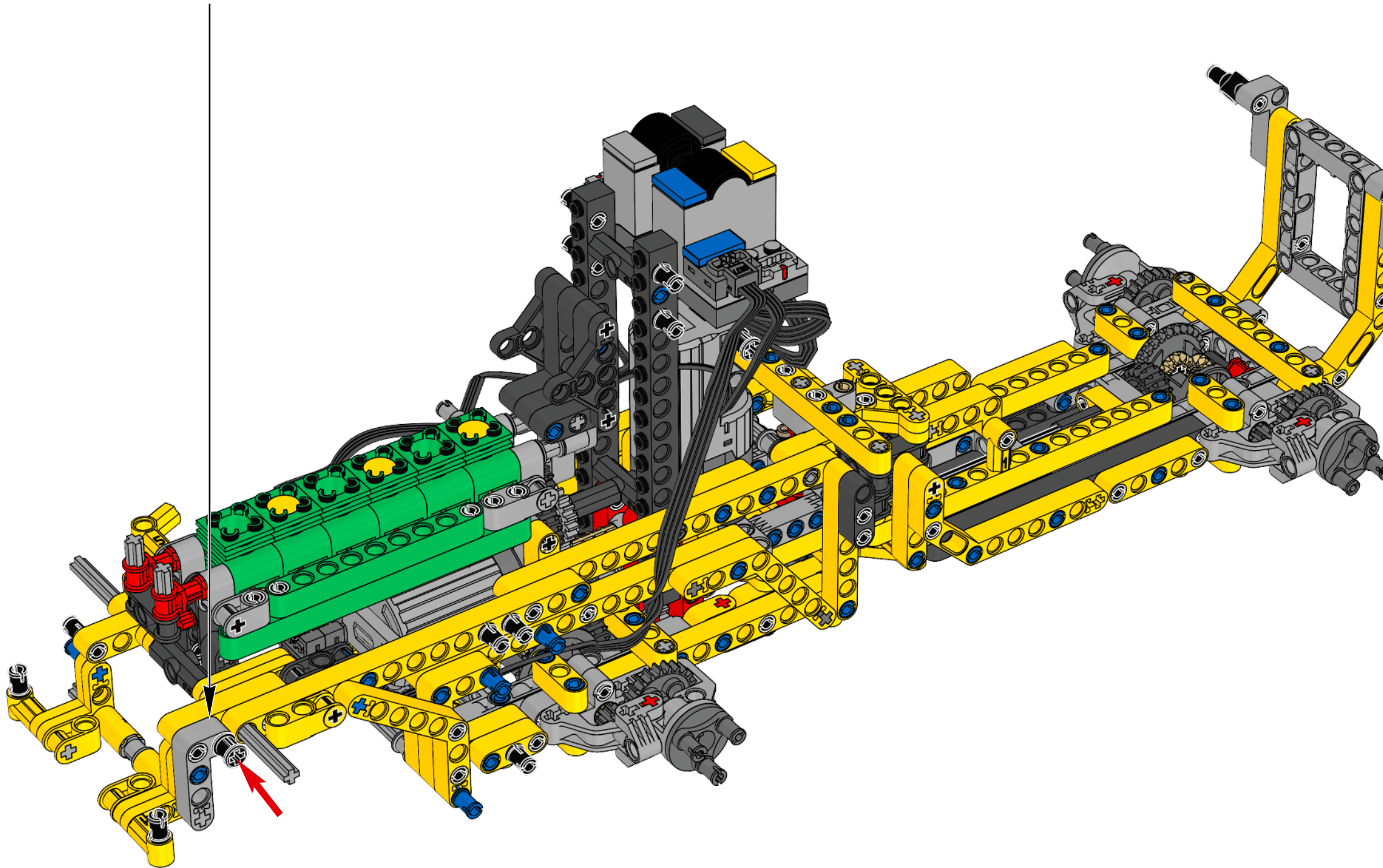

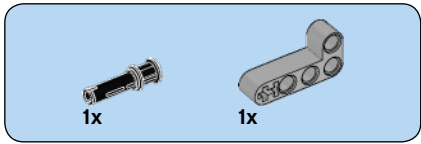

86

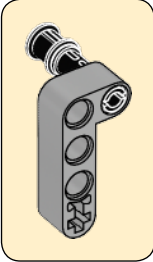
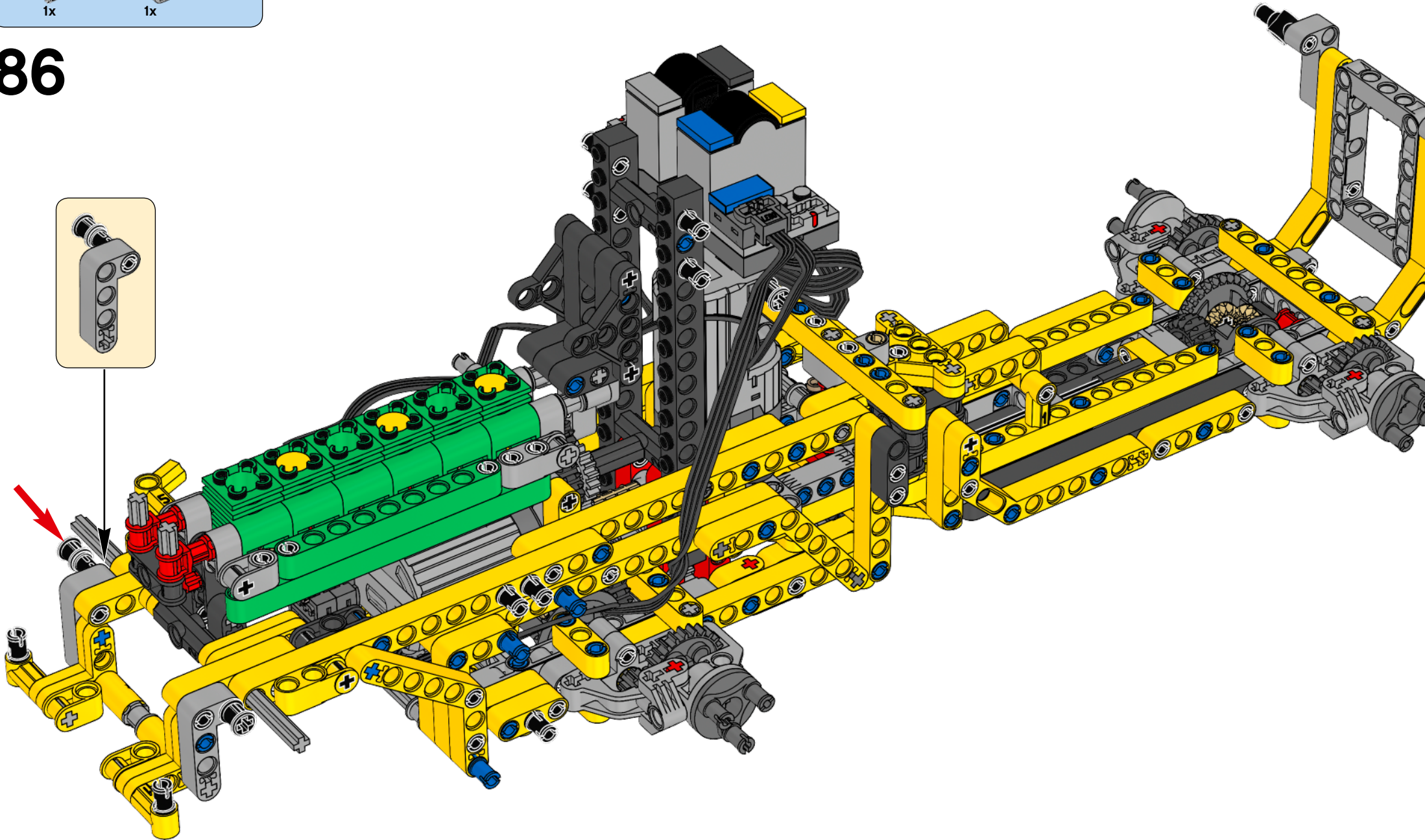

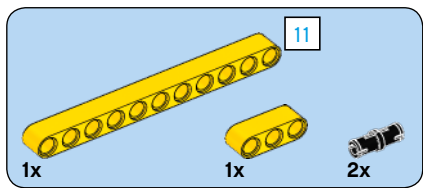

87

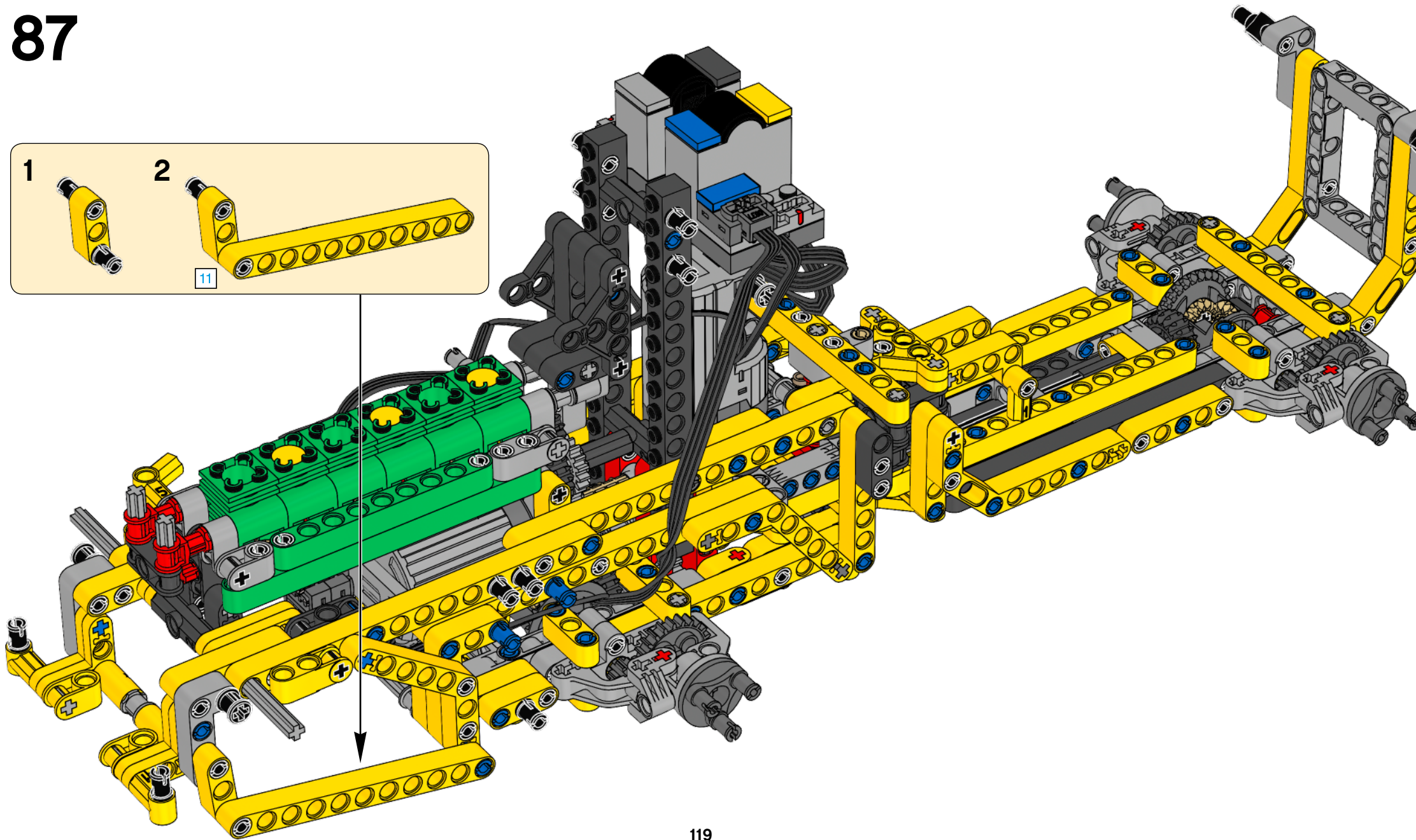
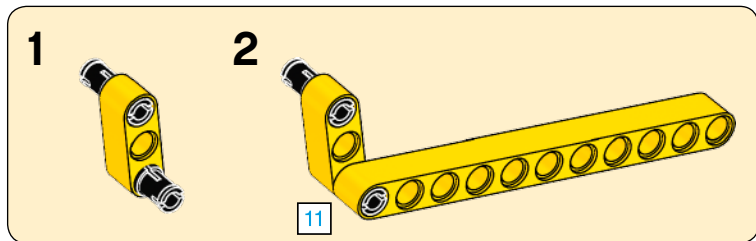

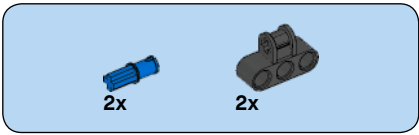

88

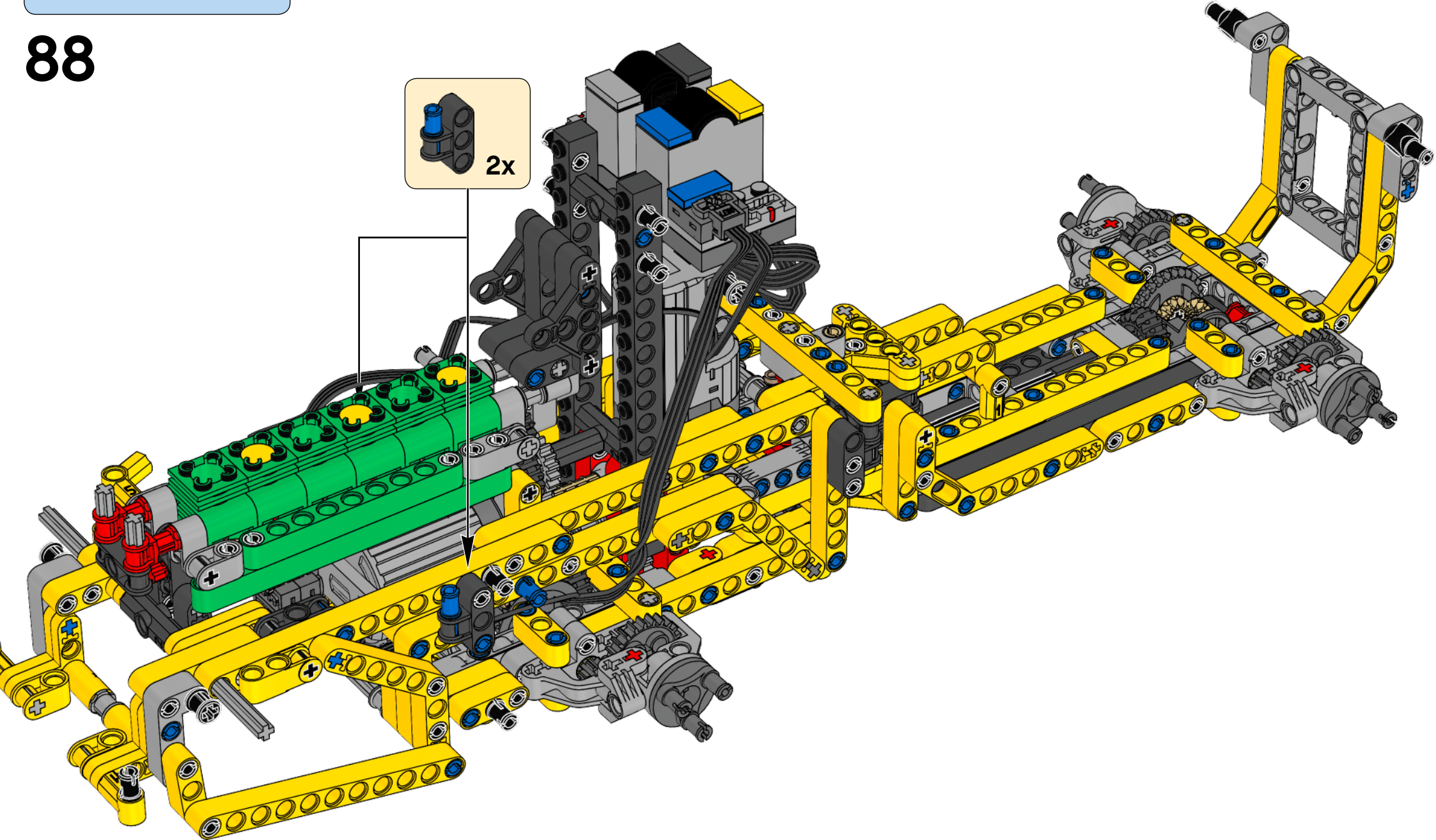

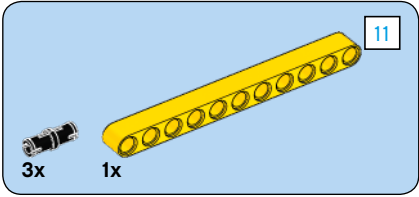
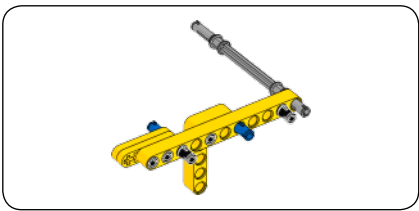

1

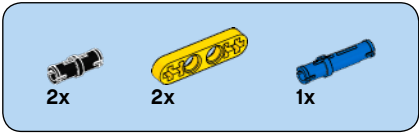
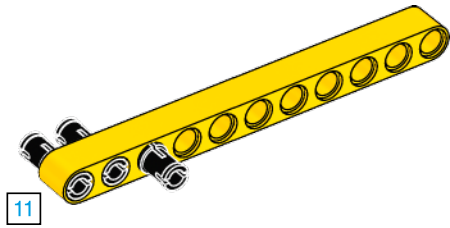

2

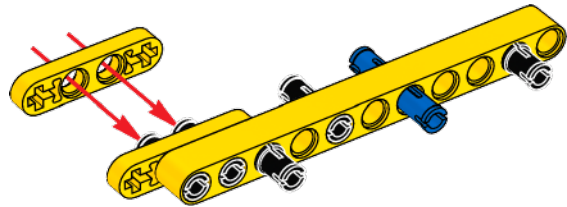

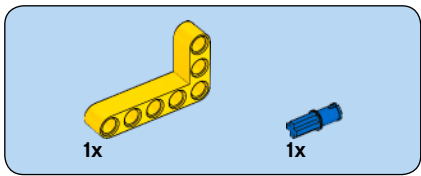

3

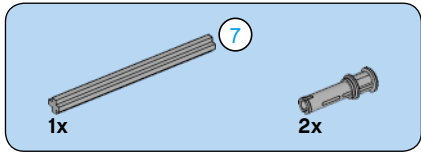
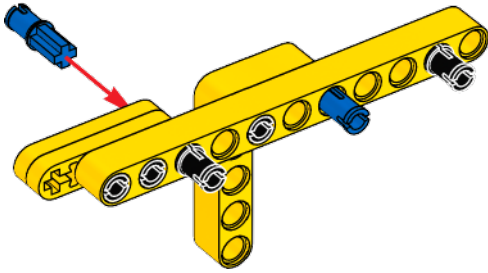

4

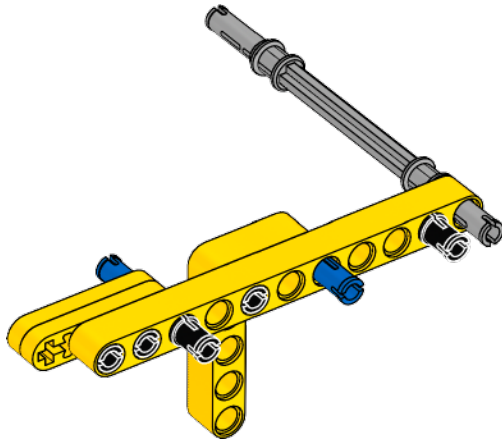
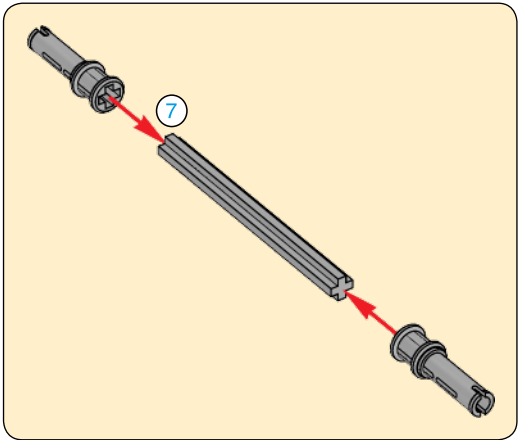

89

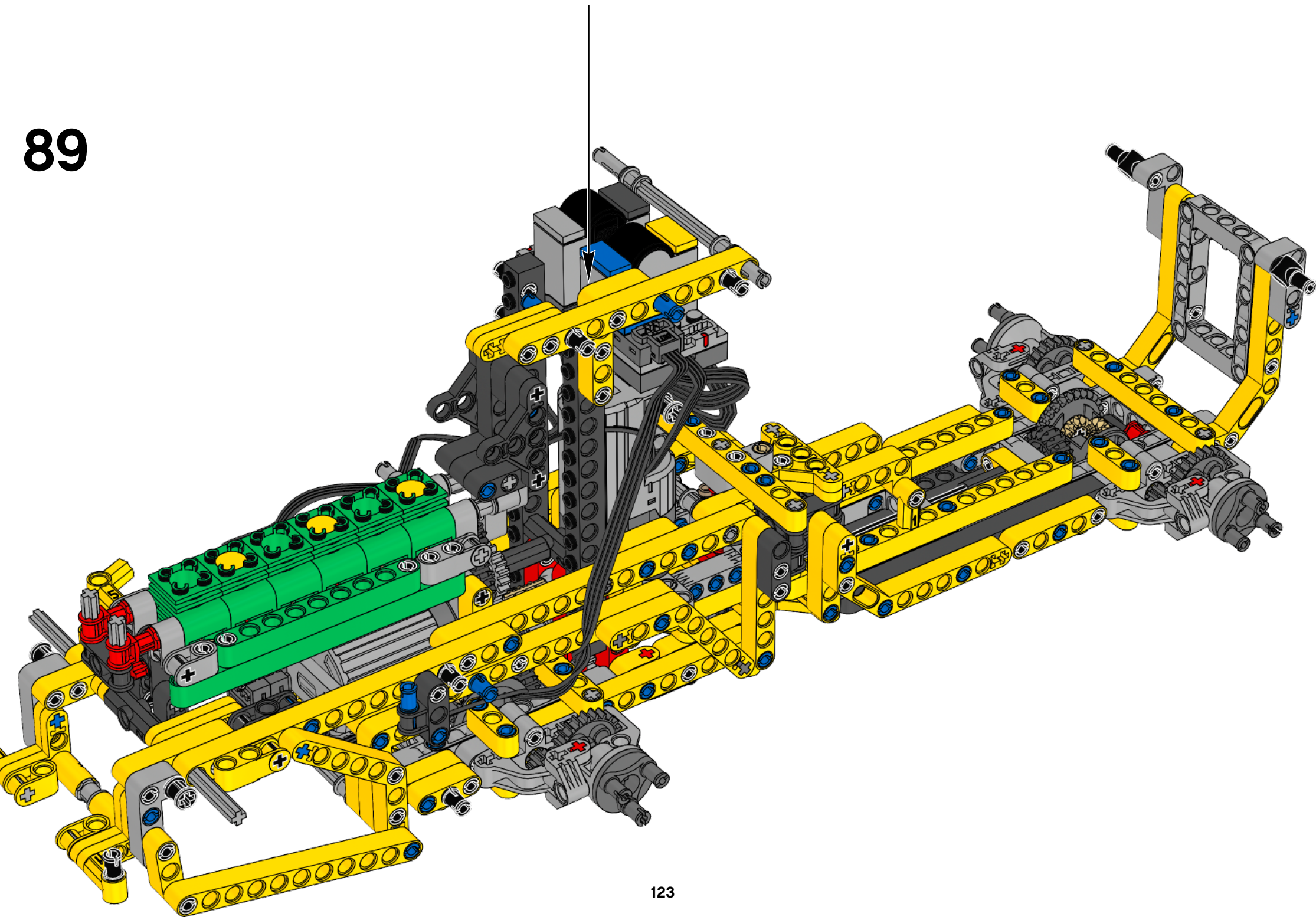

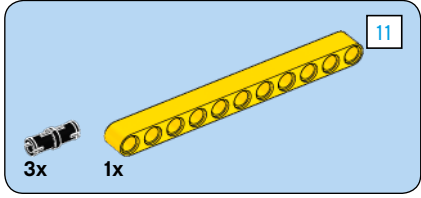
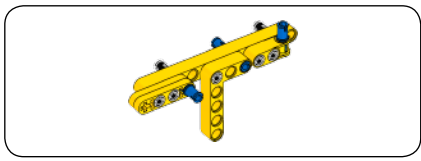

1

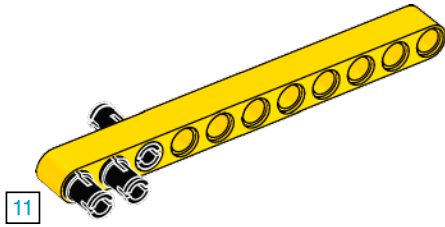

2

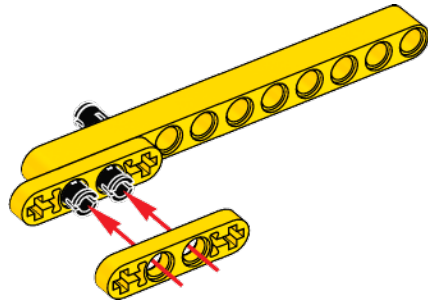

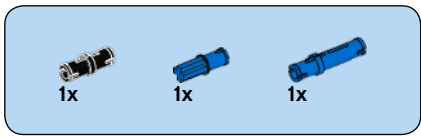

3

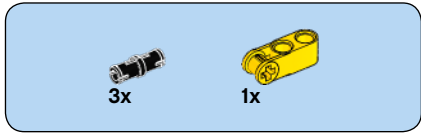
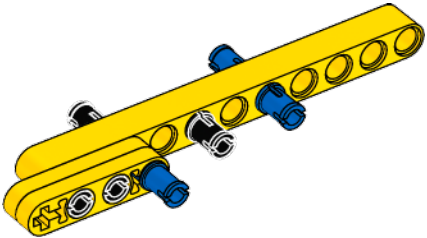

4

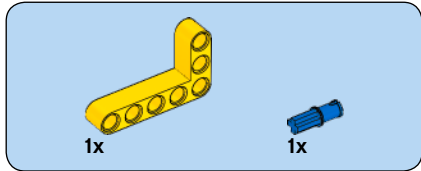
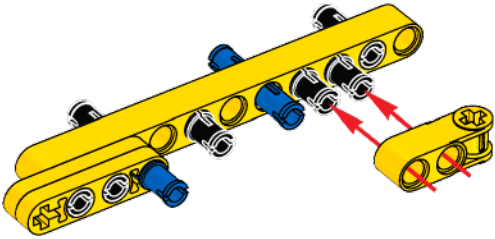

5

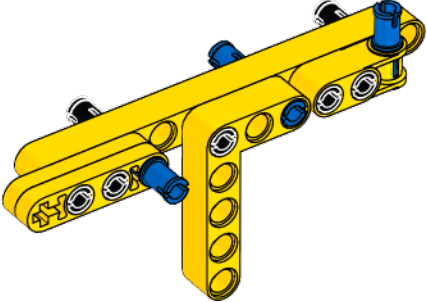

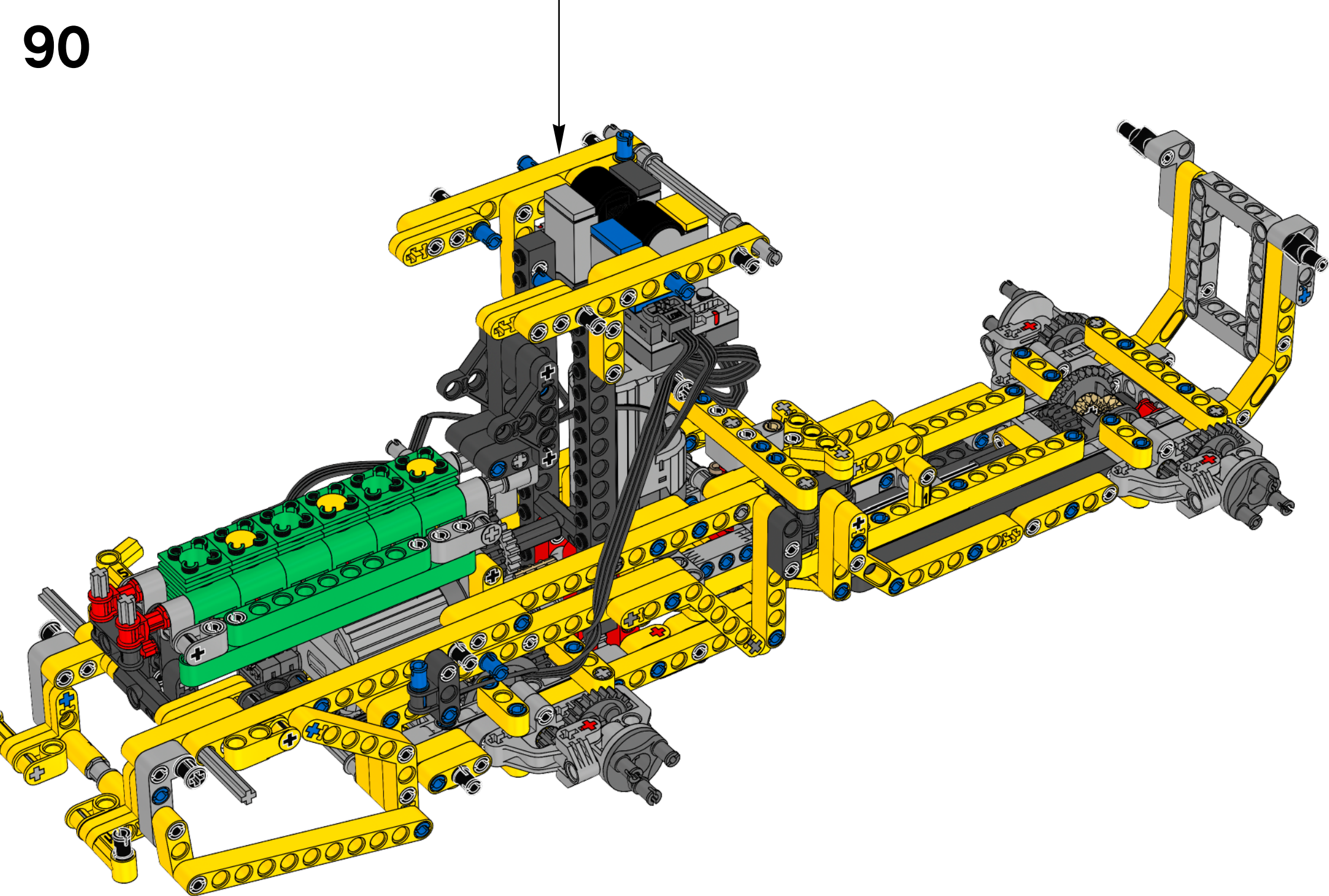

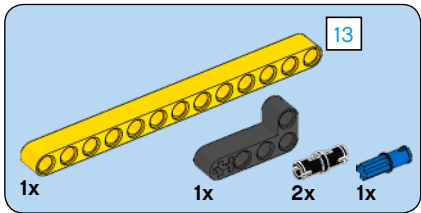

91

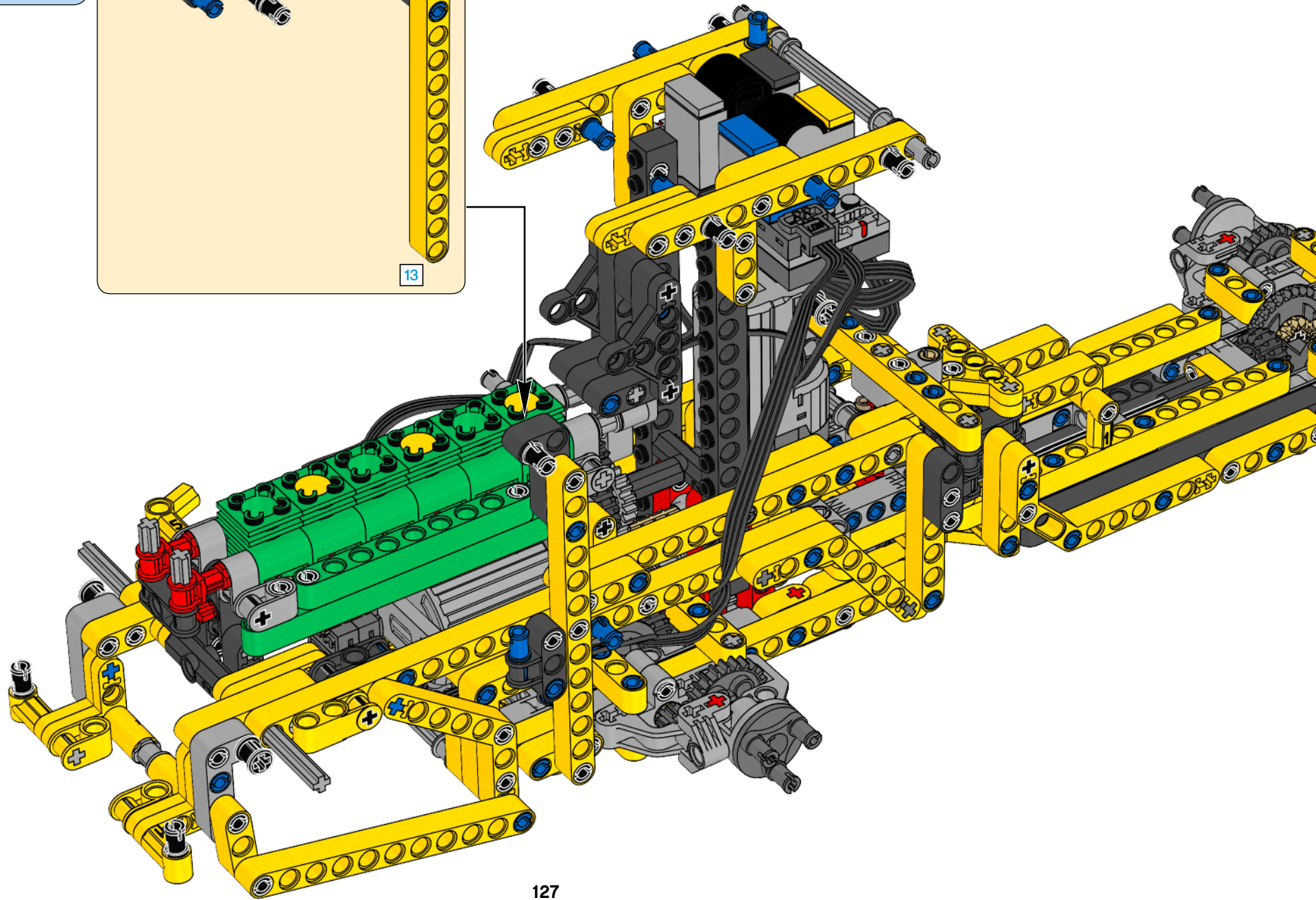
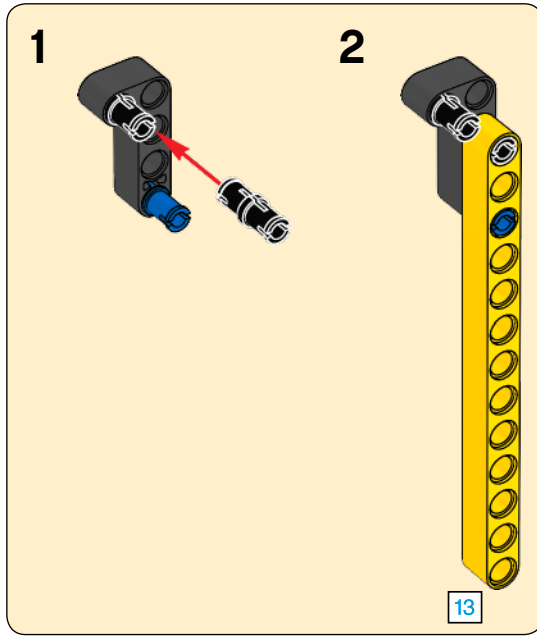

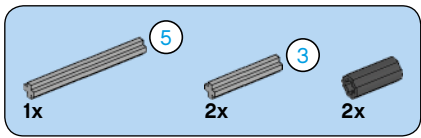

92

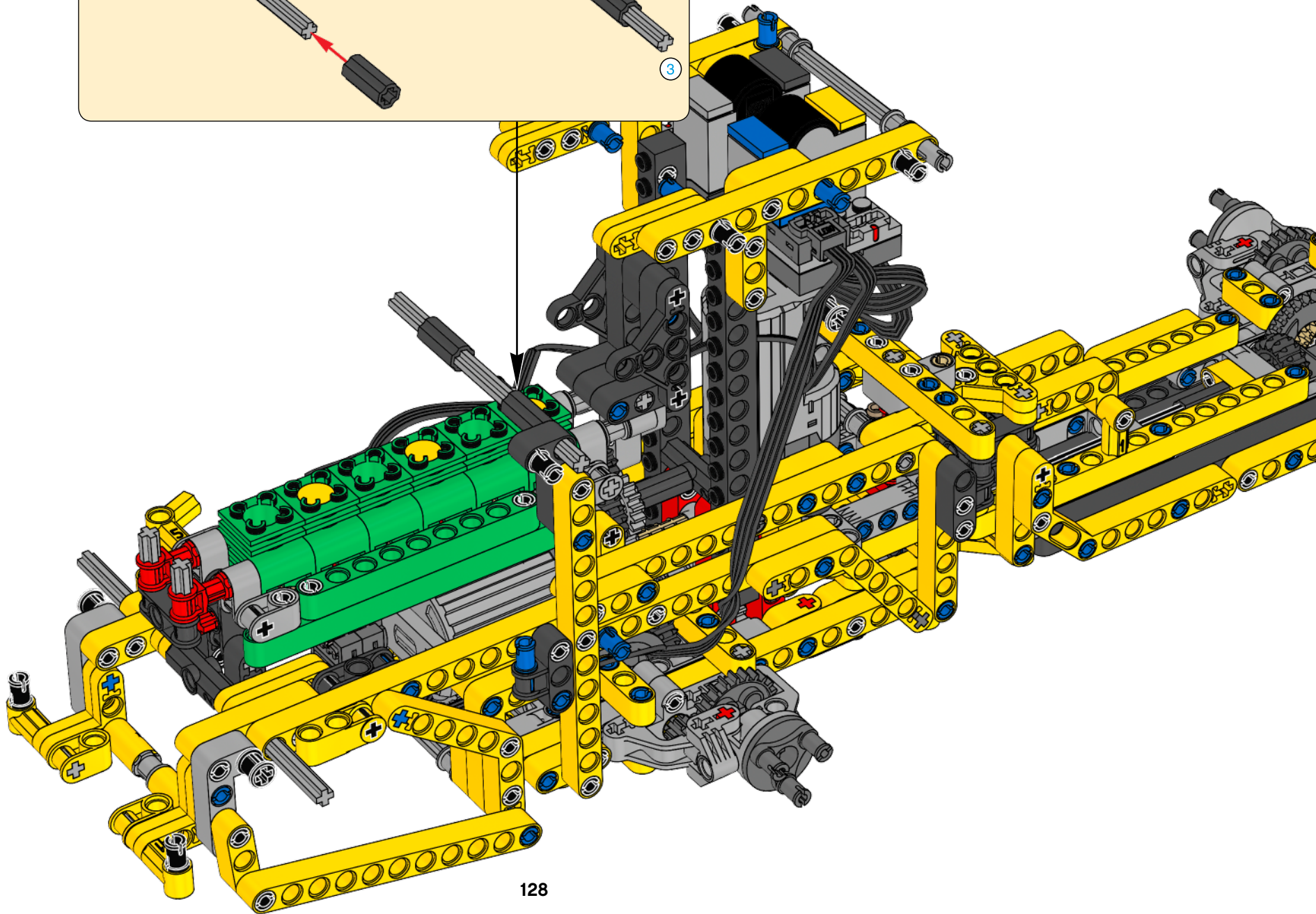
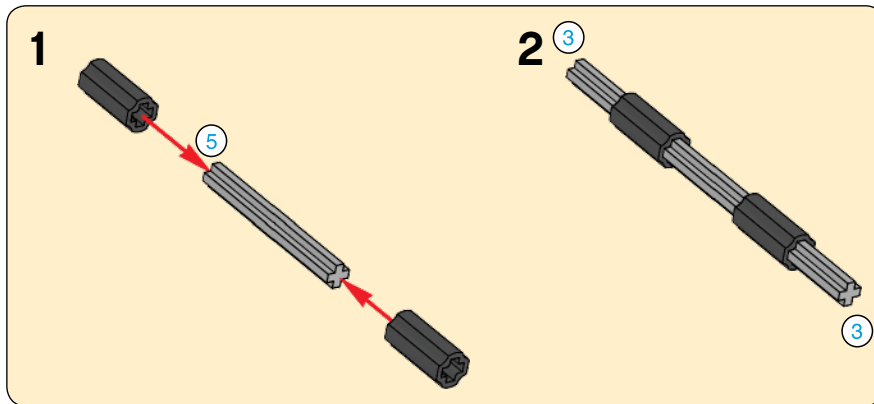

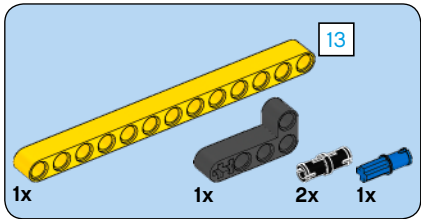

93

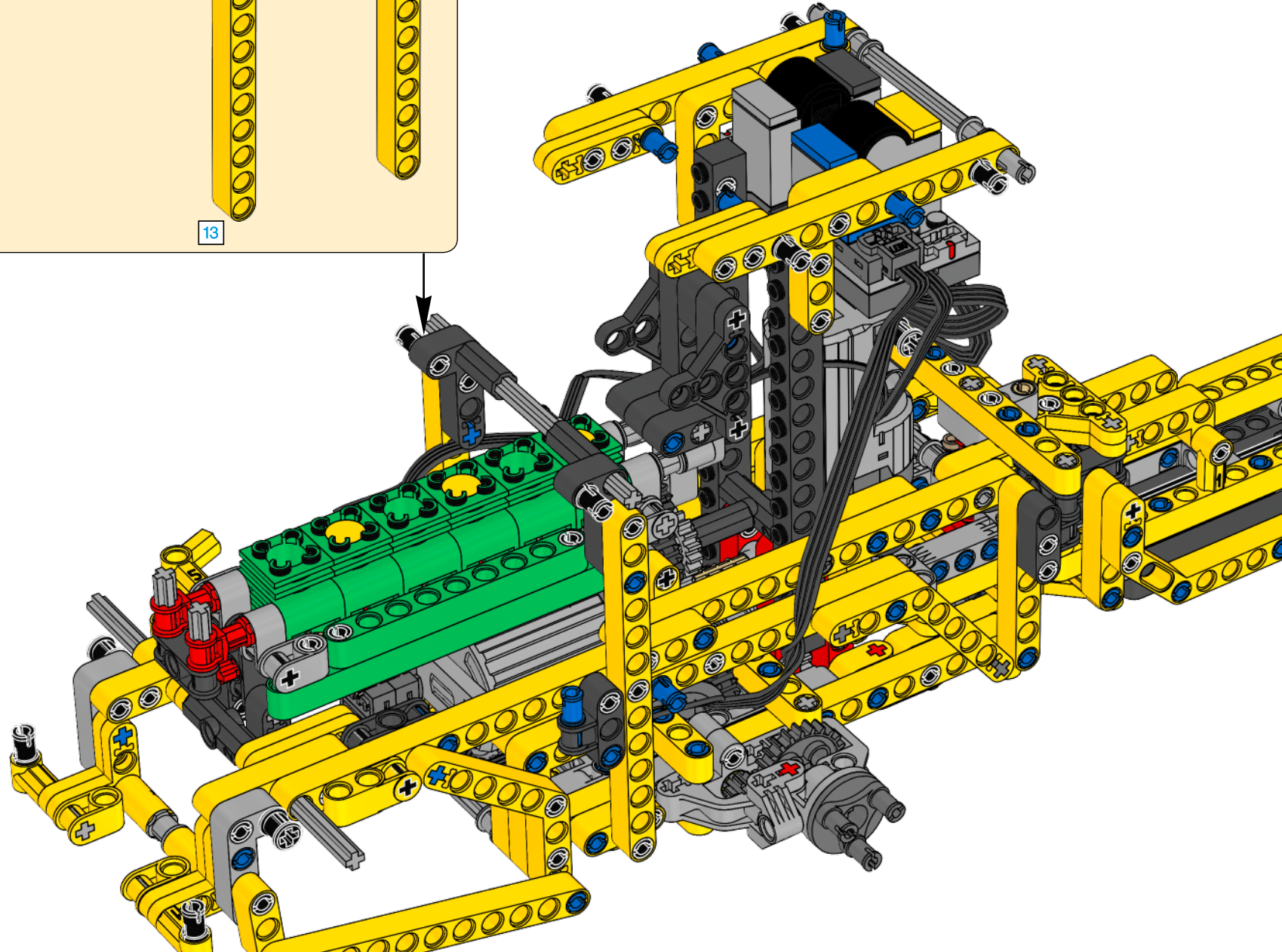
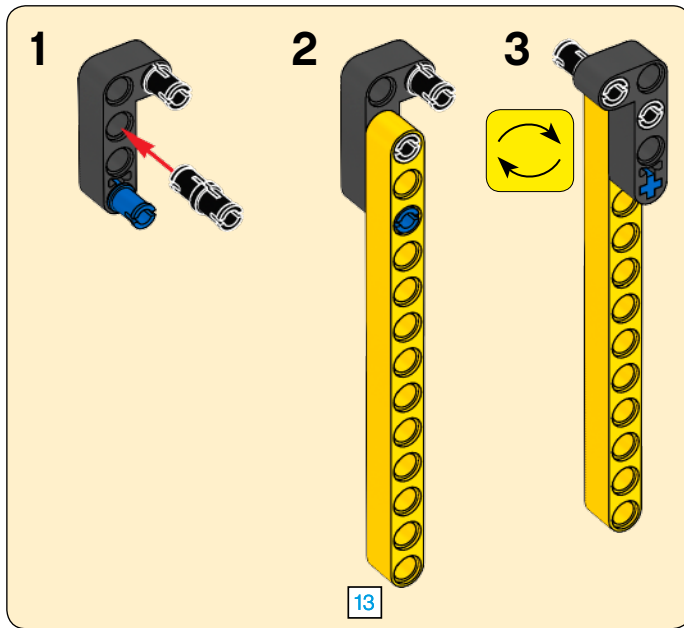



2x

94

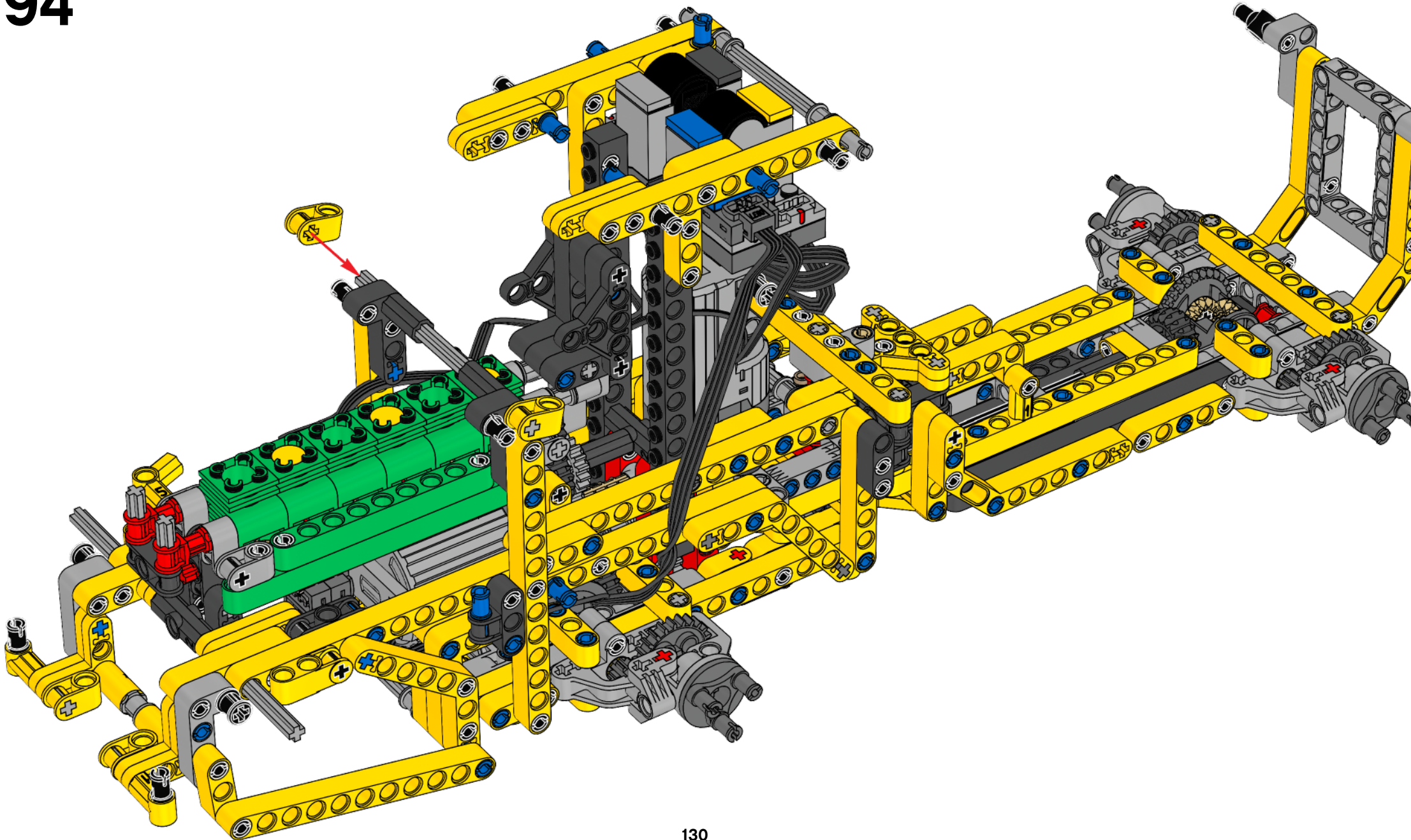

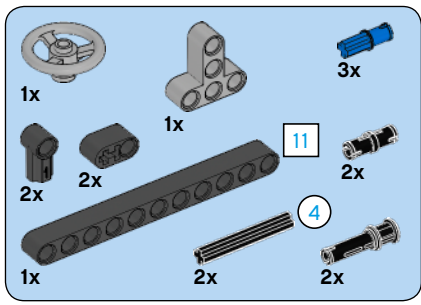

95

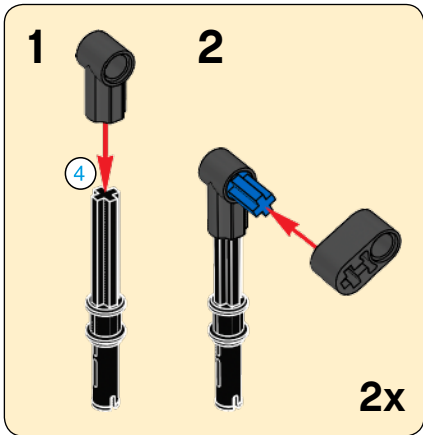
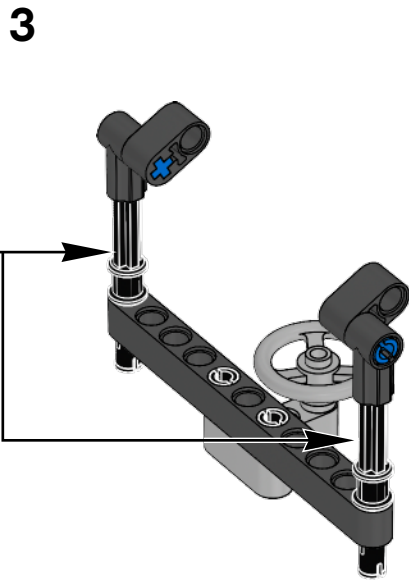
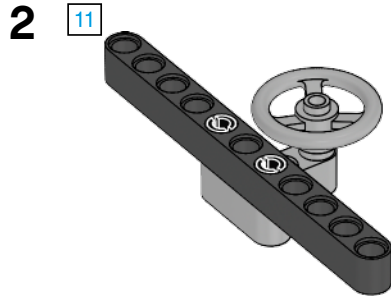
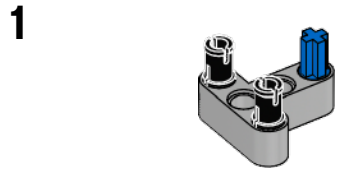

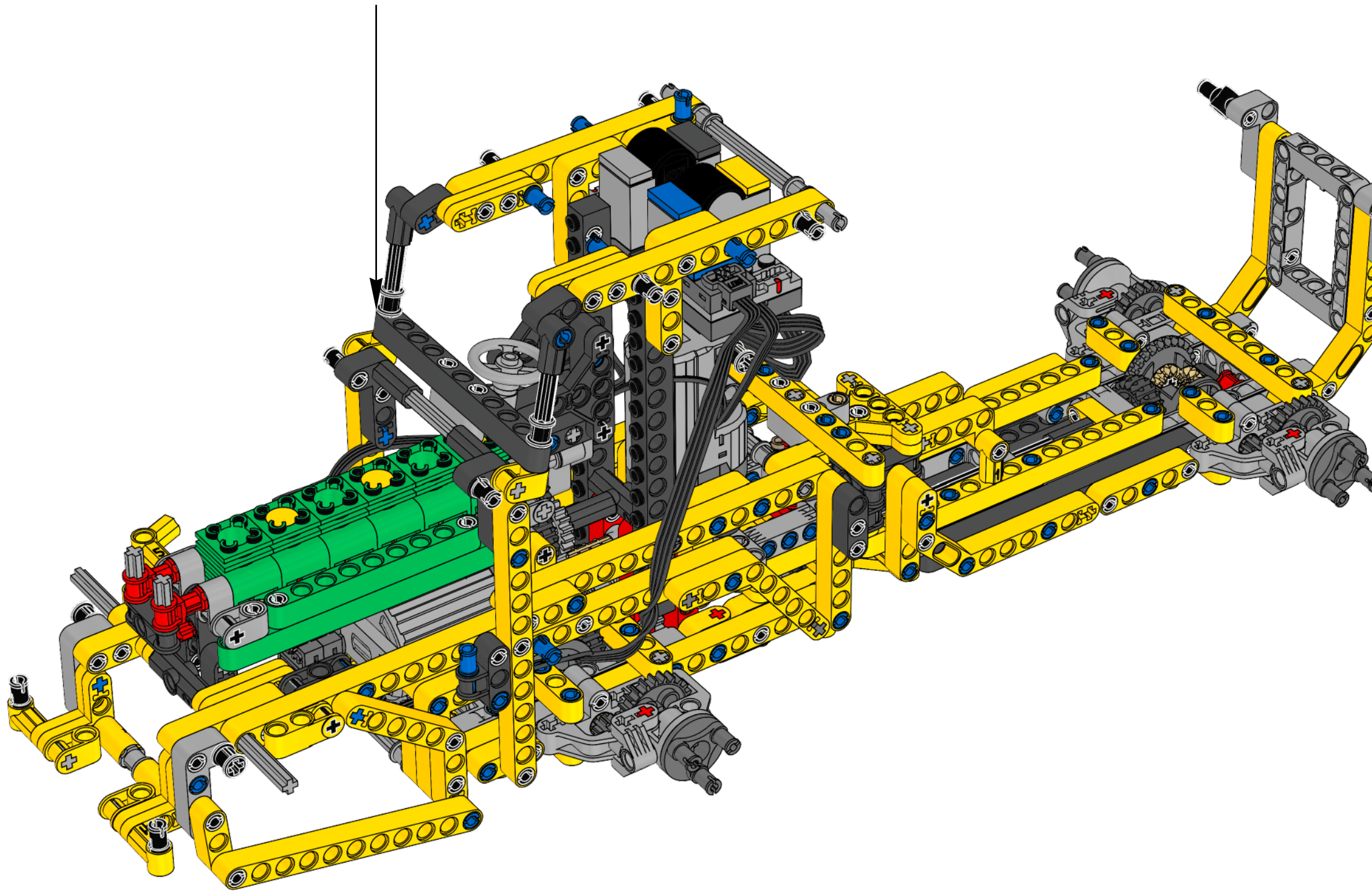

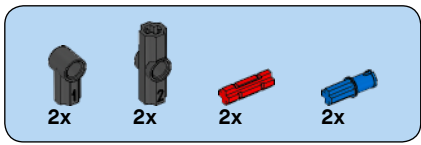

96

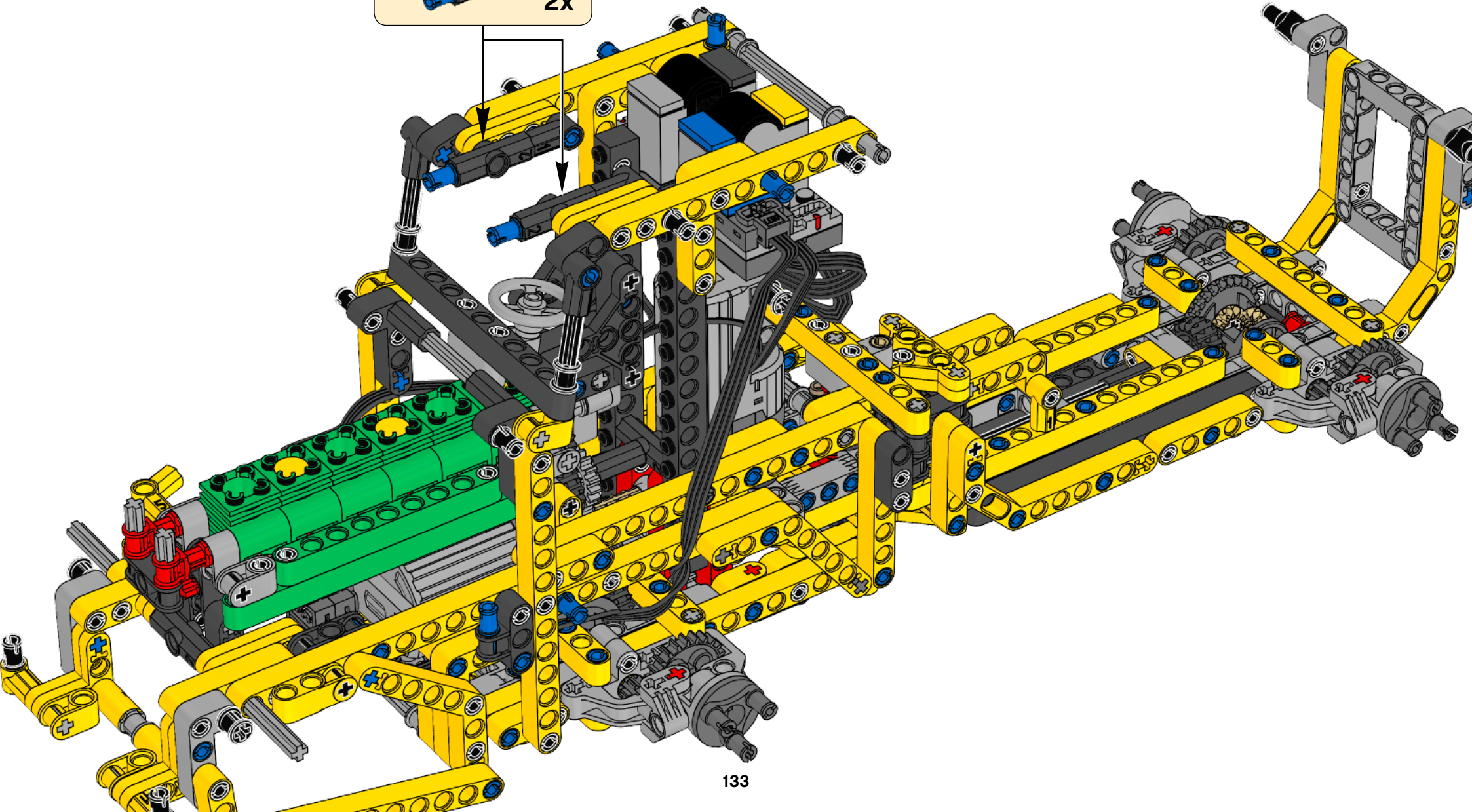
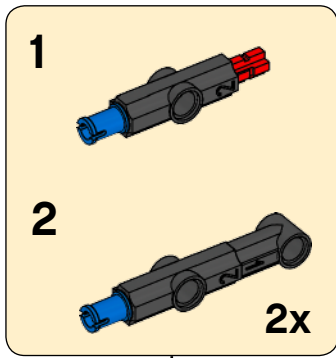

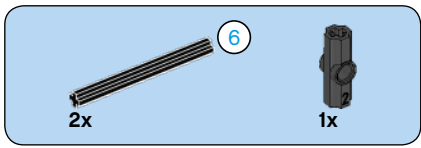

97

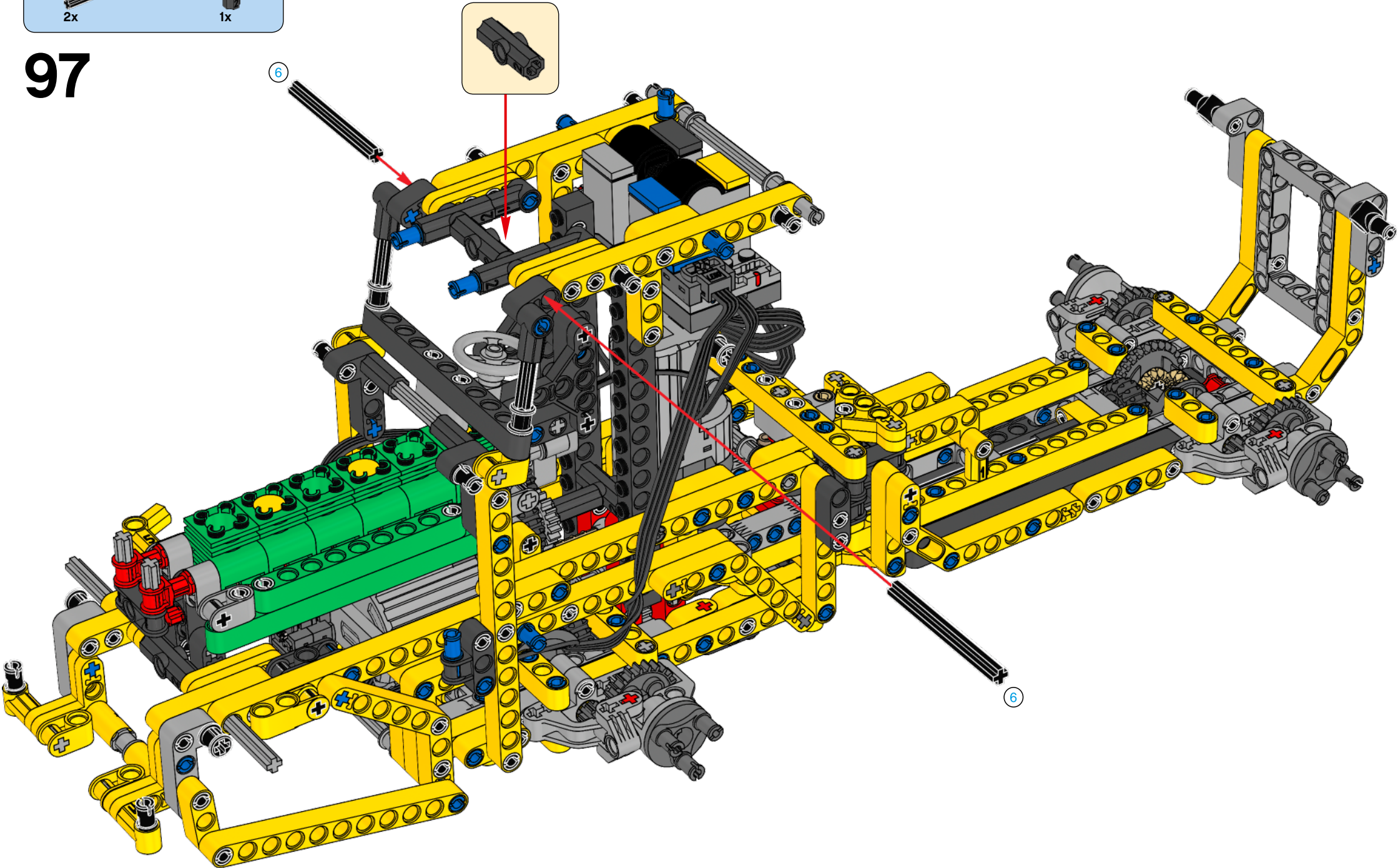

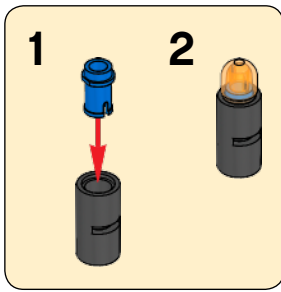
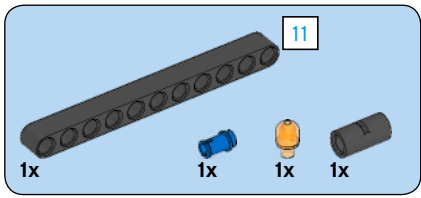

98

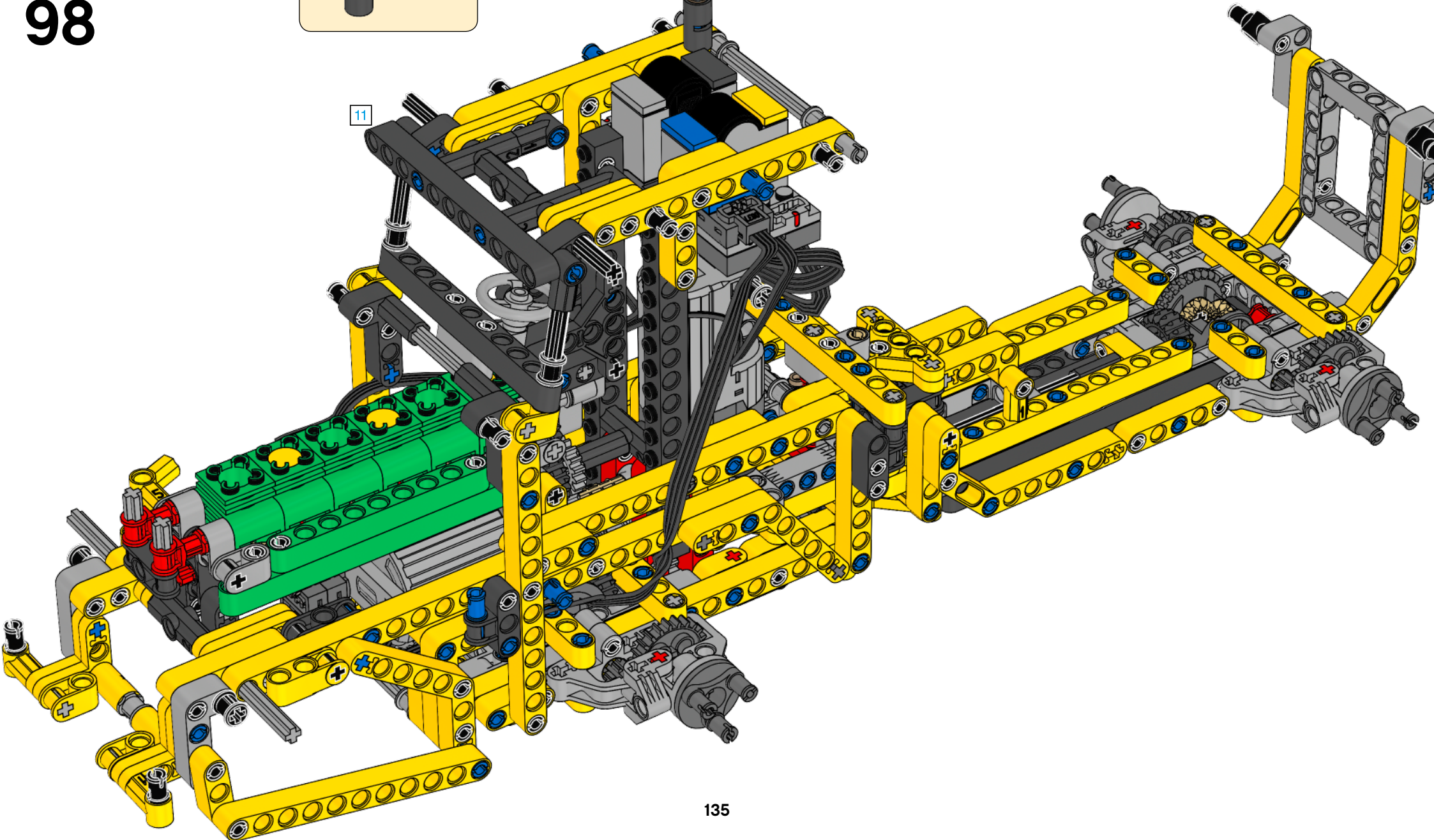

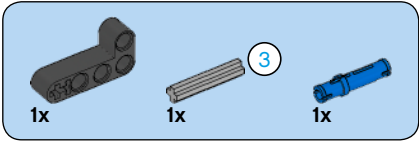
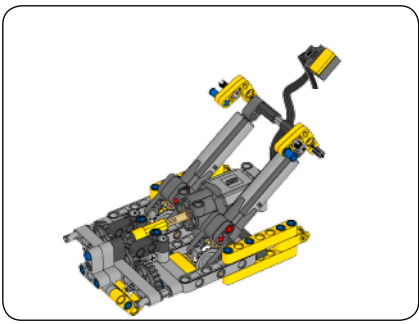

1

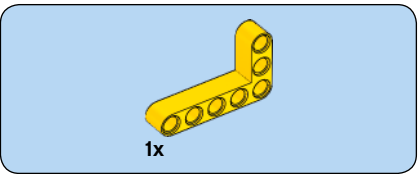

2

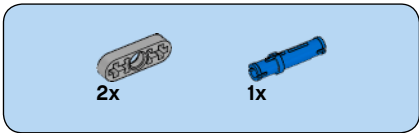

3

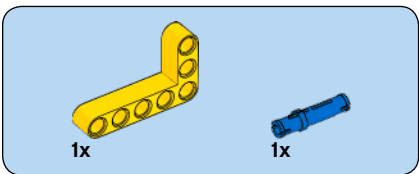

4

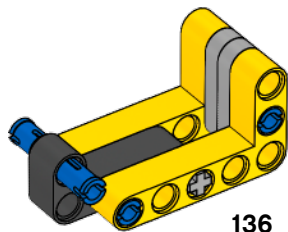
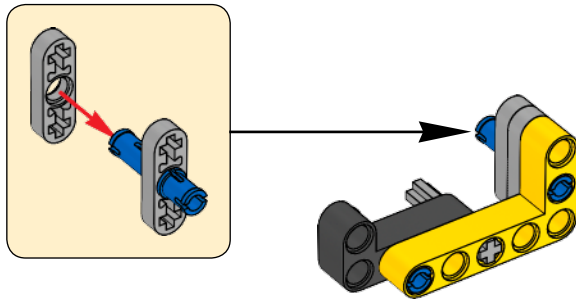
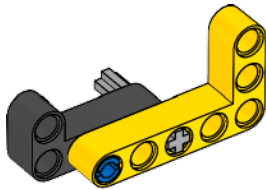
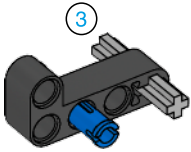

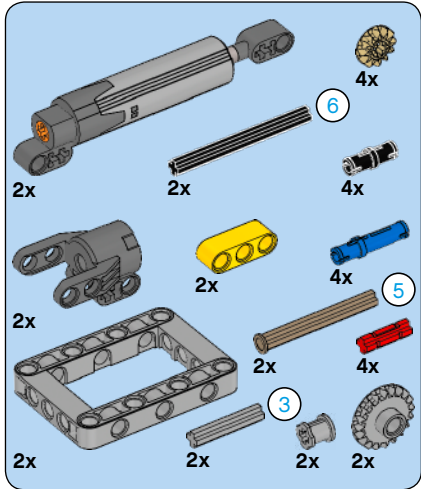
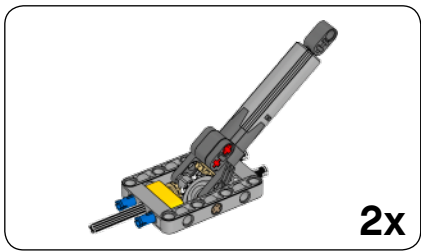

5

1

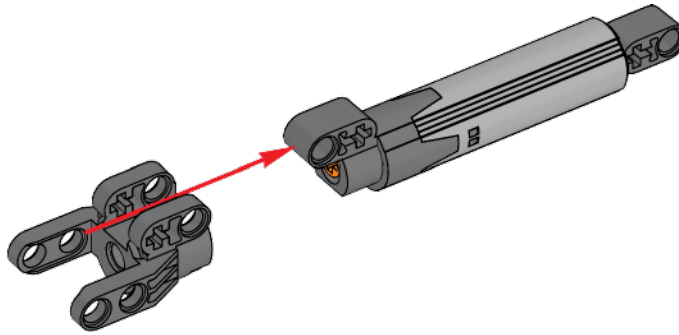

2

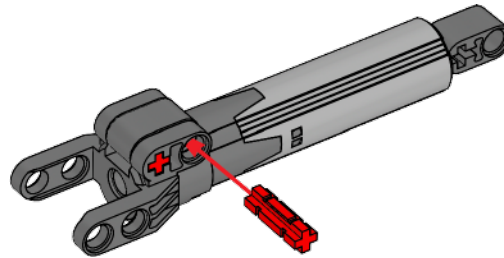

3

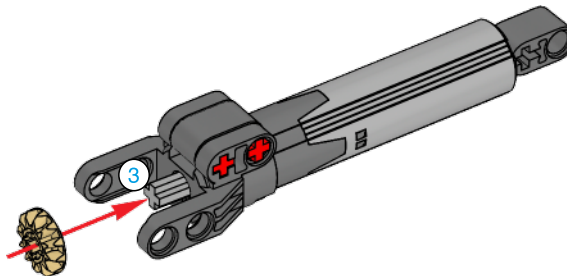

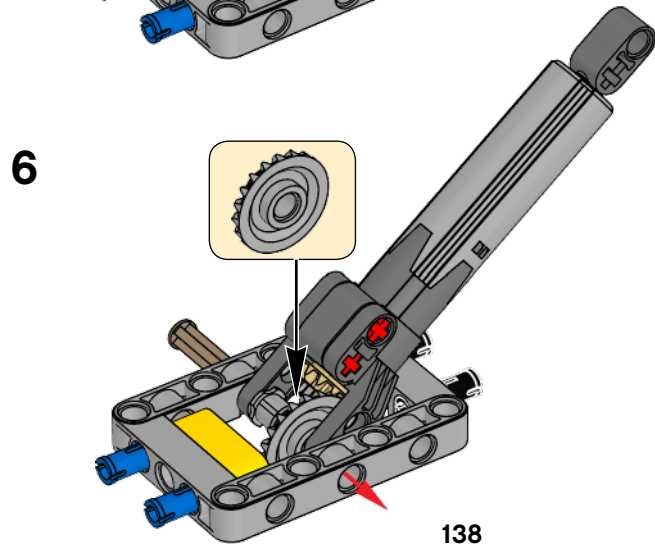
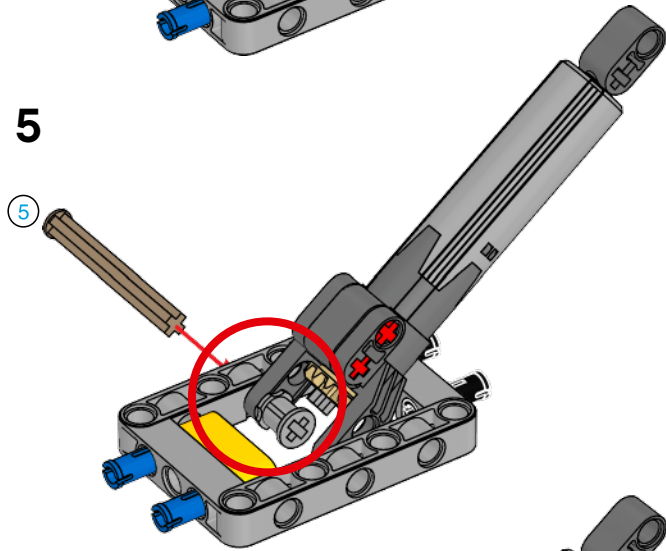
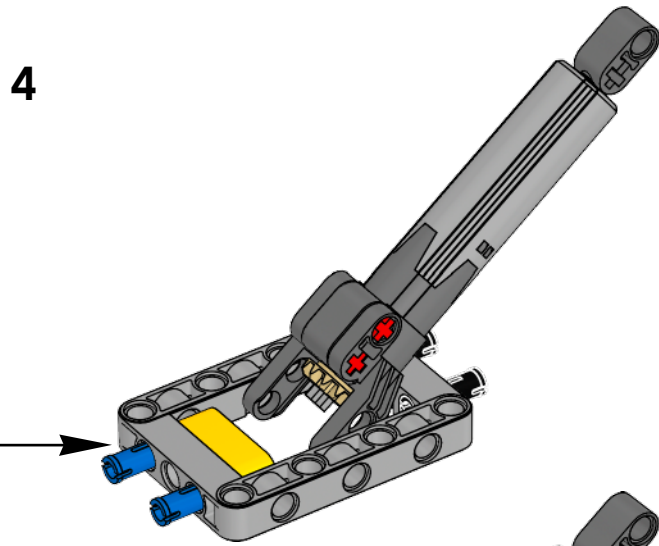
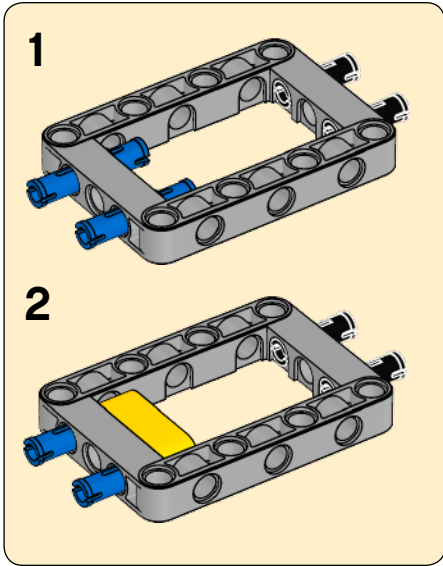

7

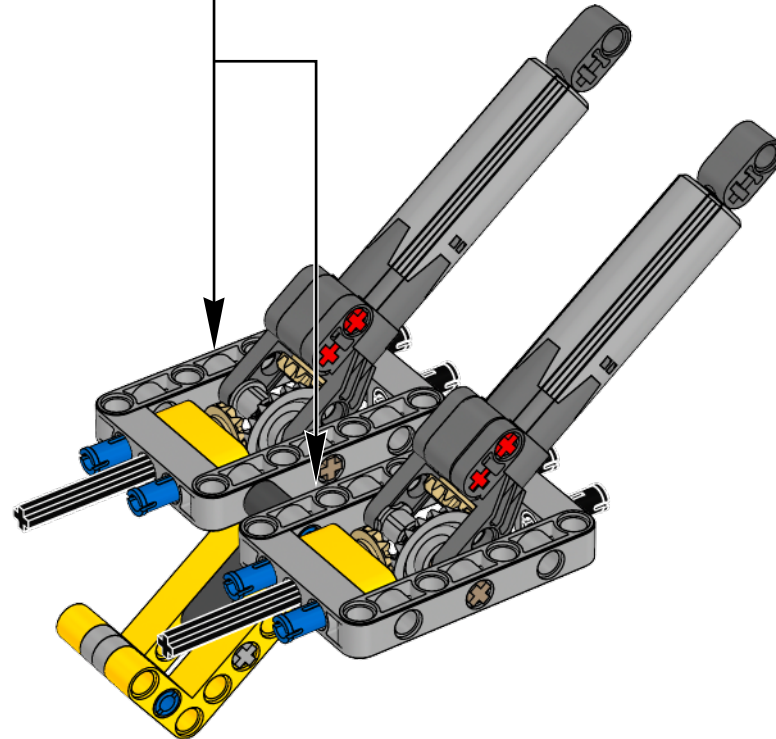
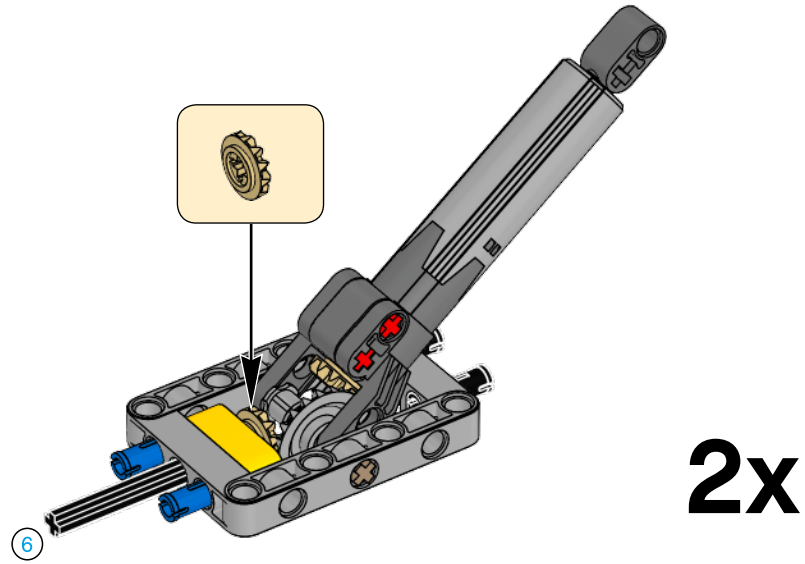

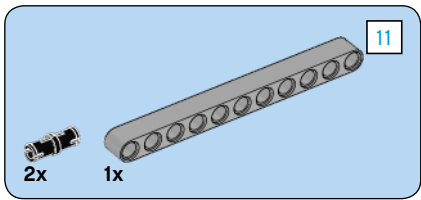

6

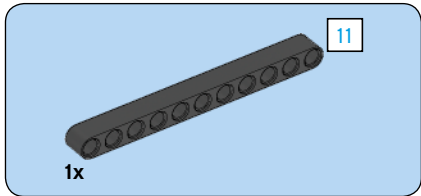
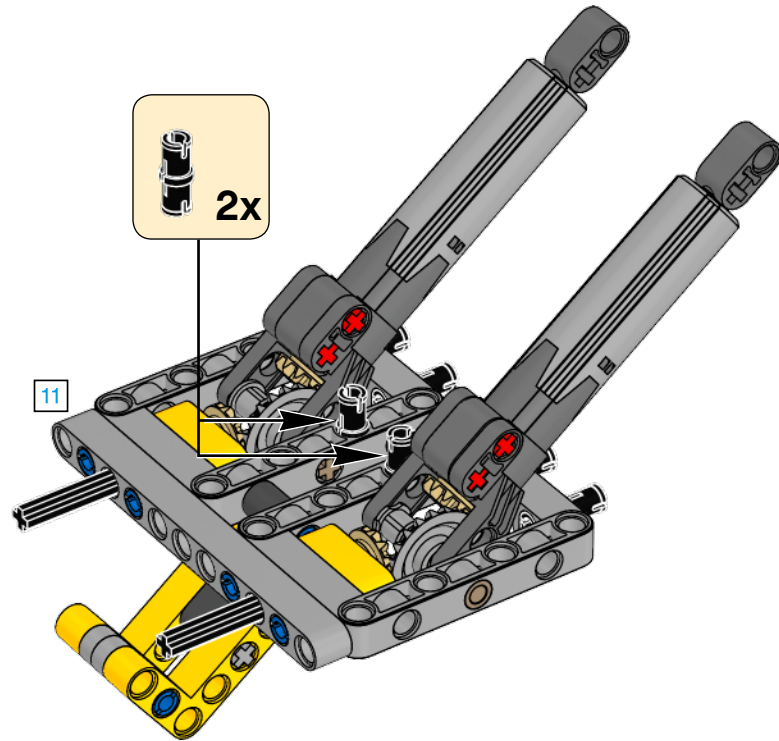

7

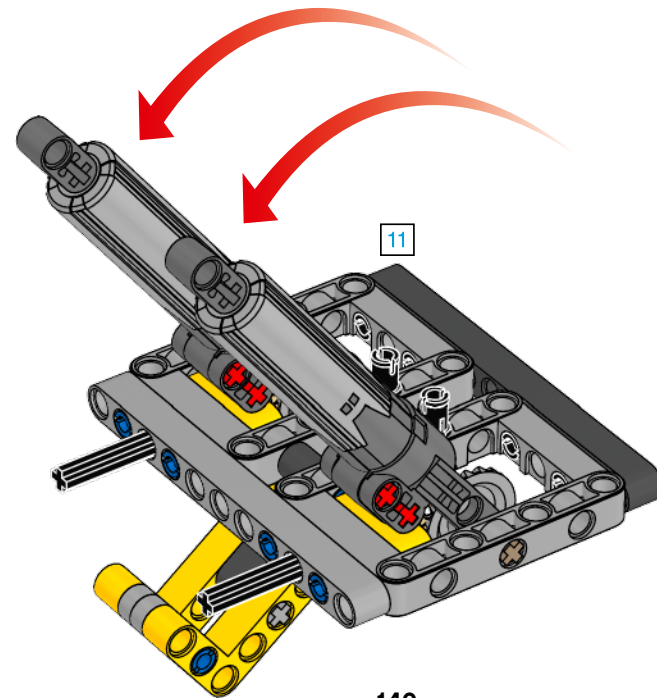

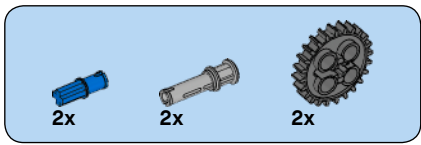

8

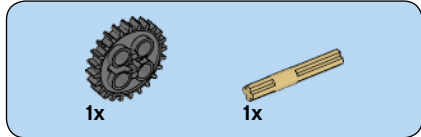
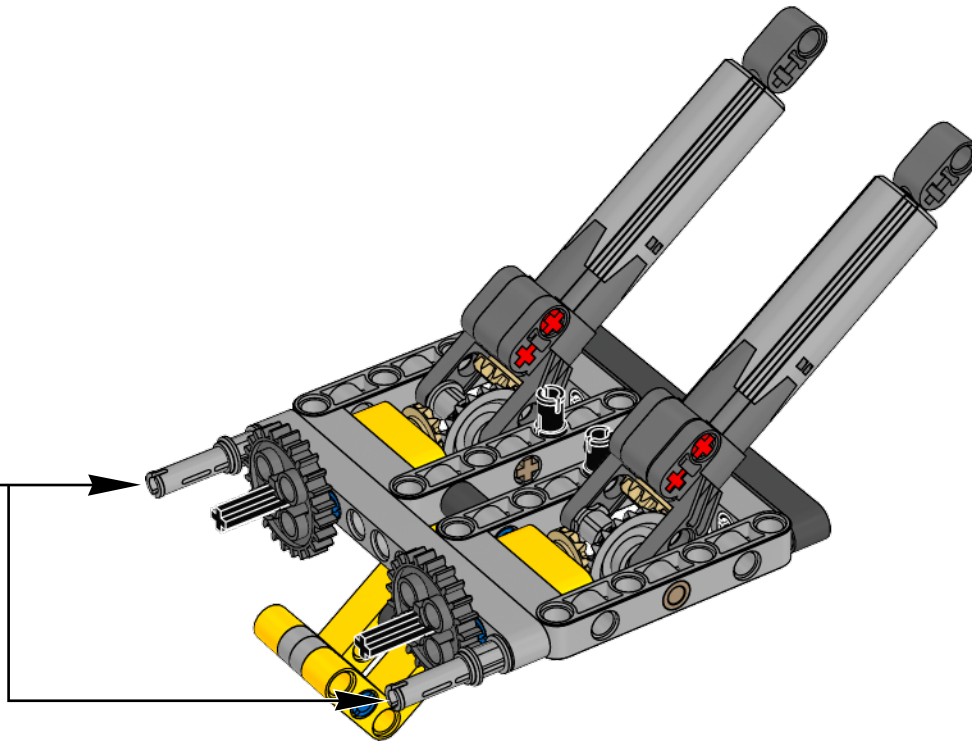
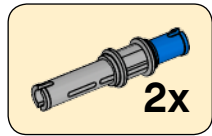

9

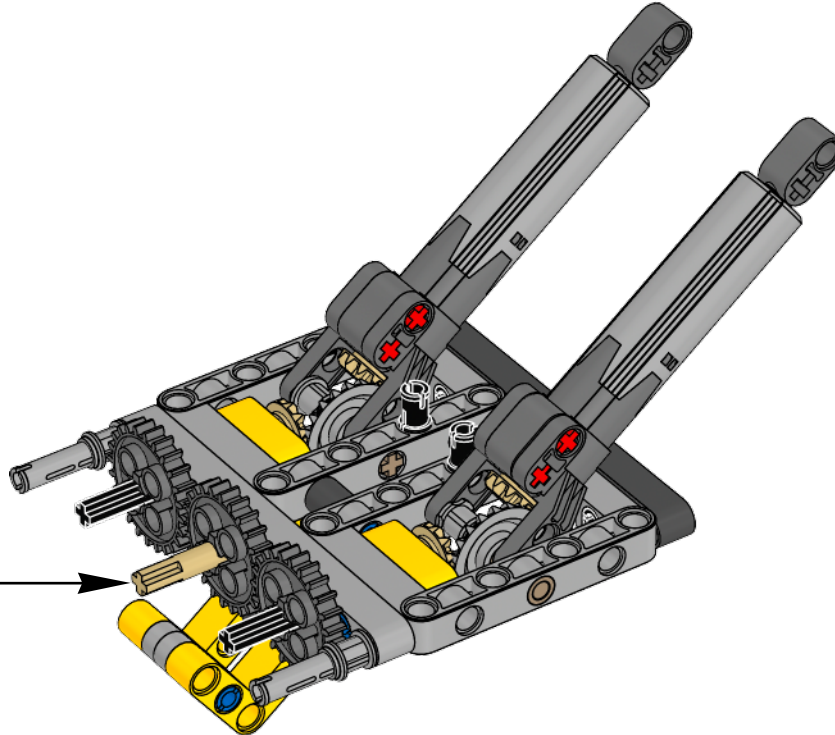
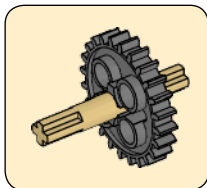

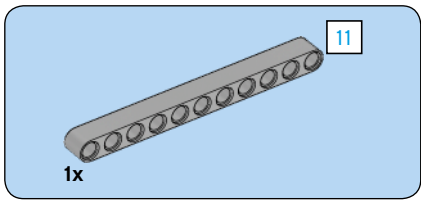

10

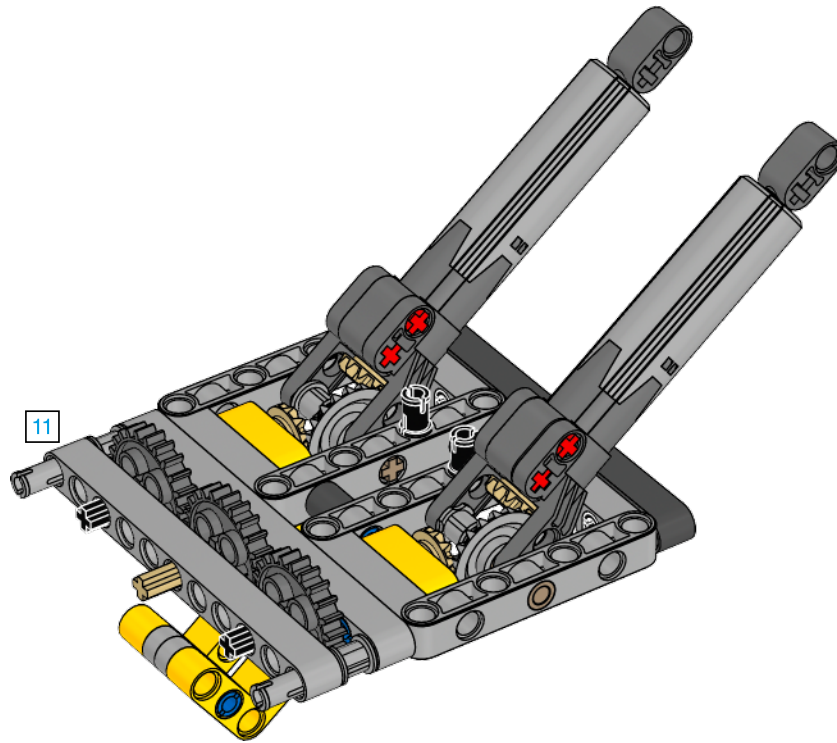

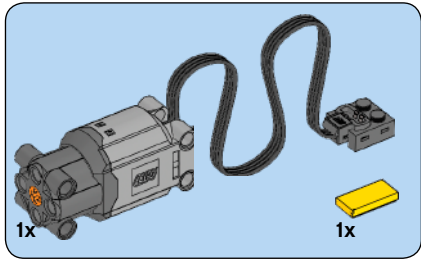
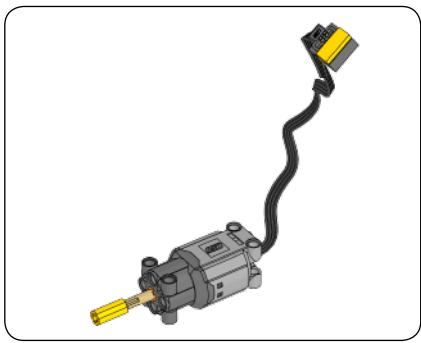

1

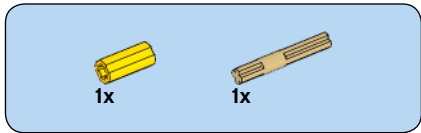

2

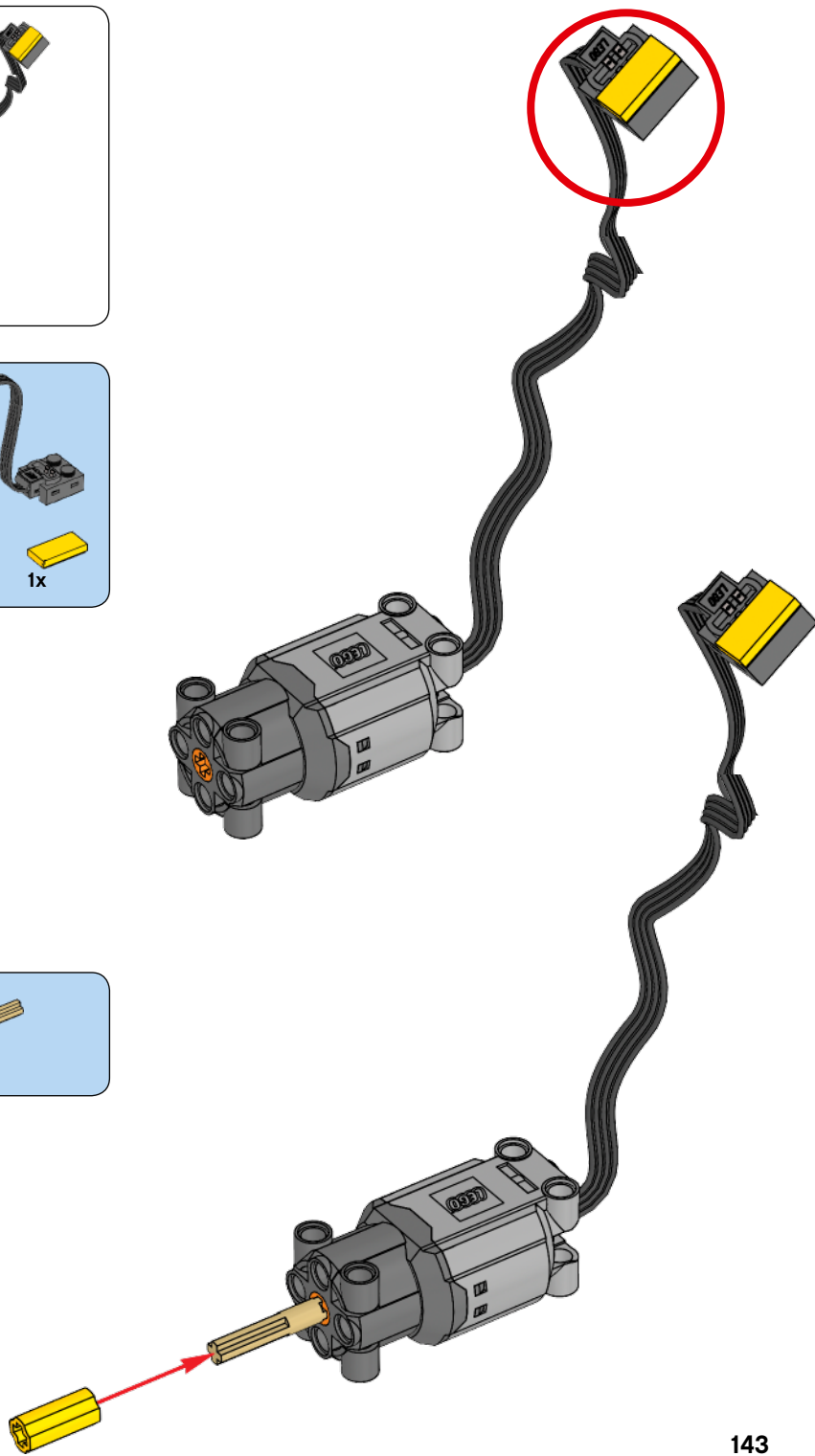

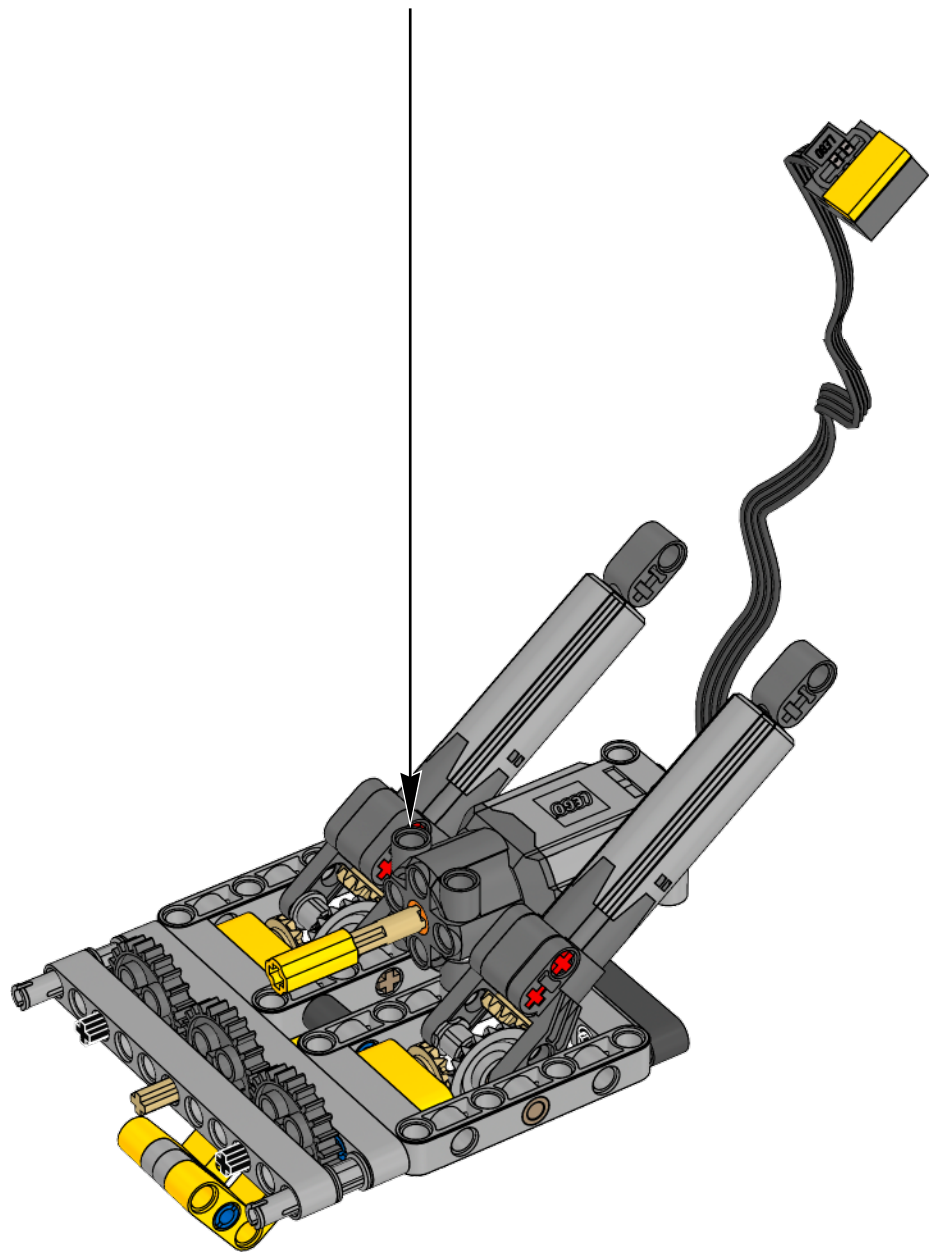

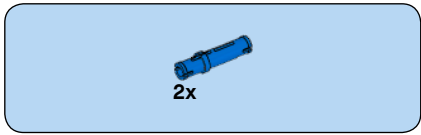

12

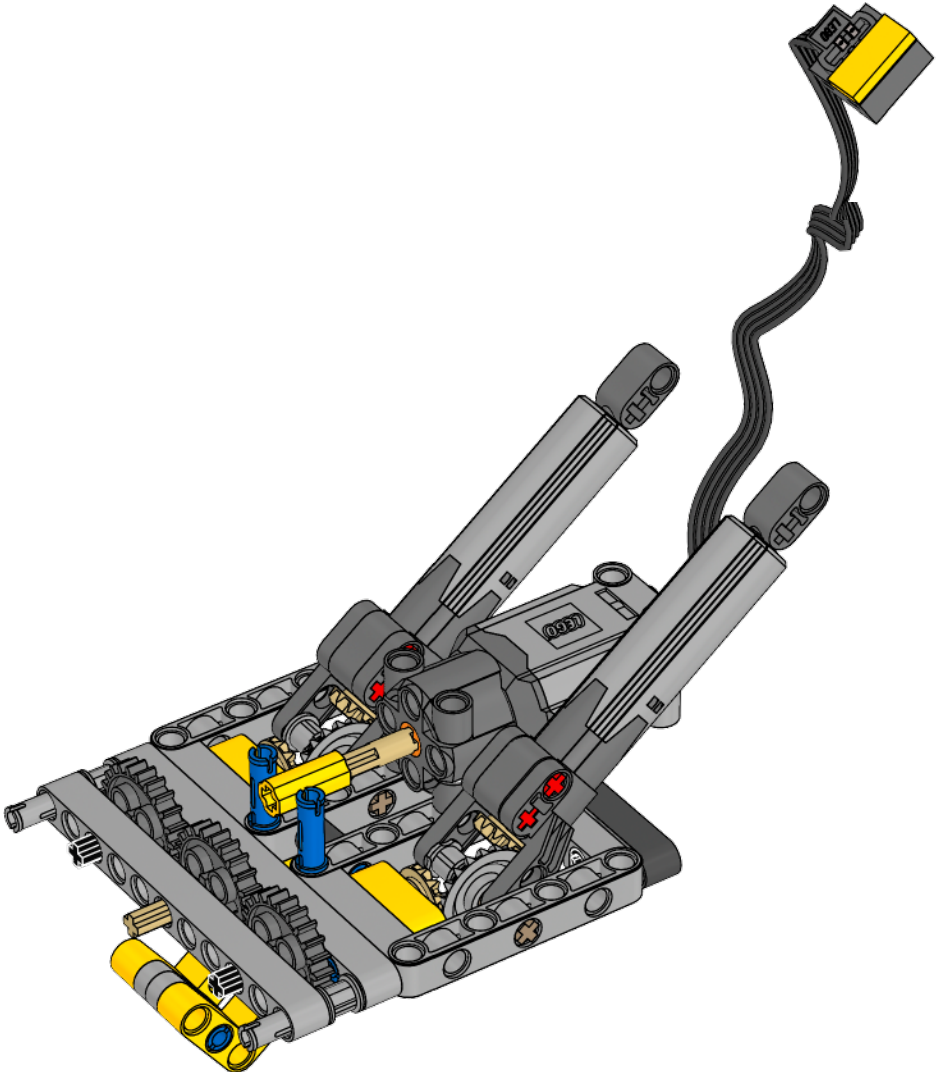

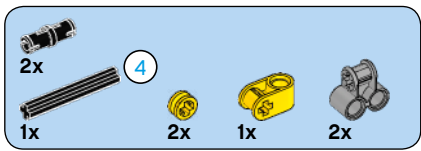

13

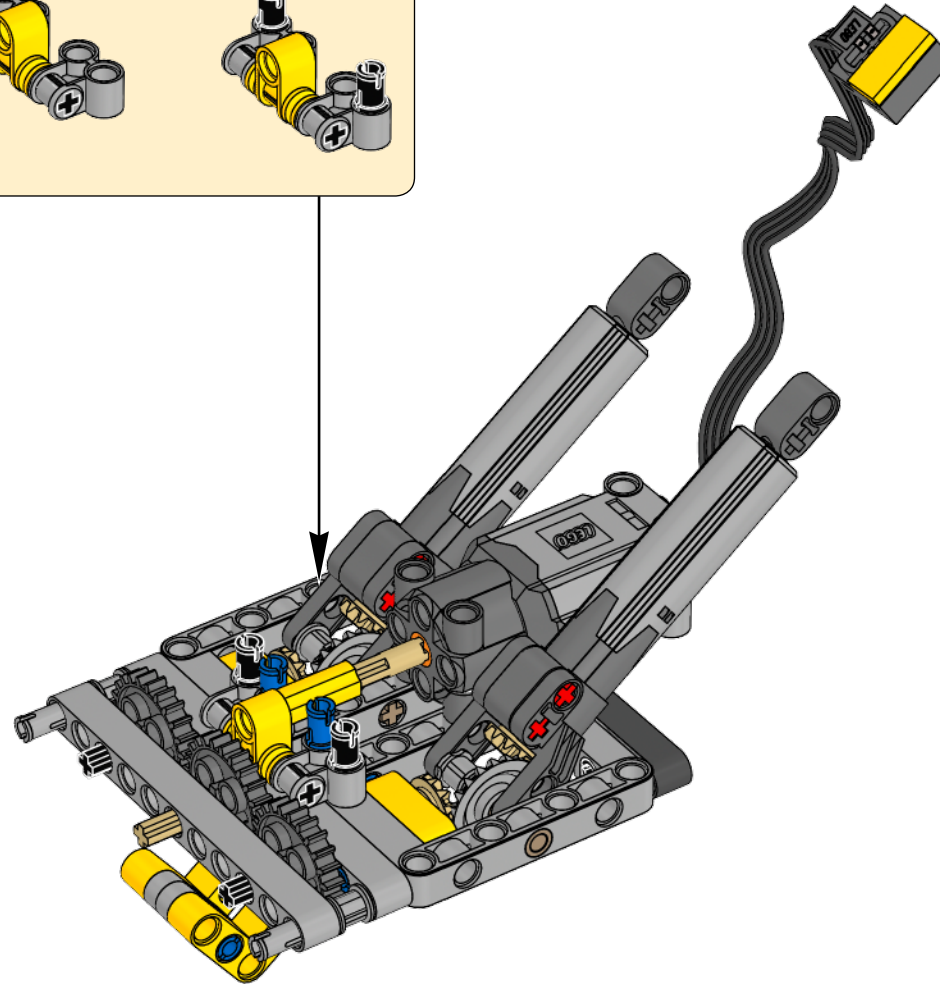
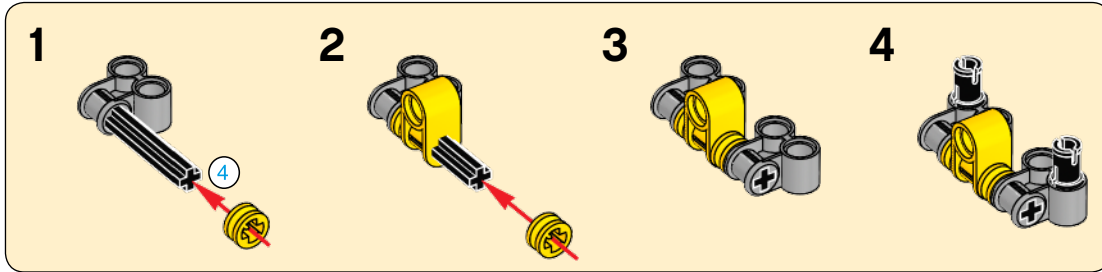

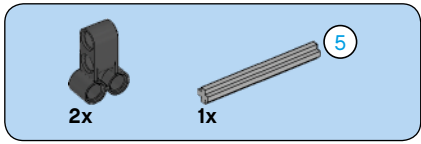

14

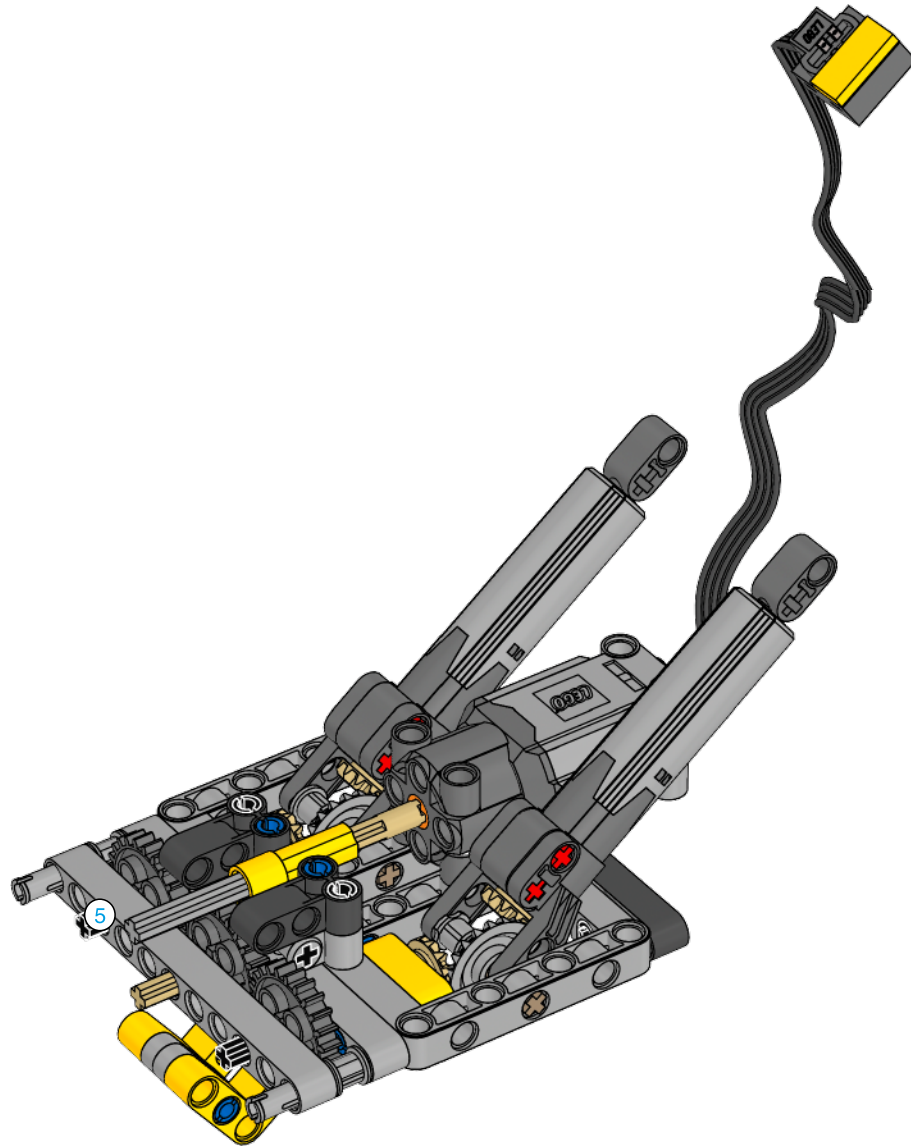

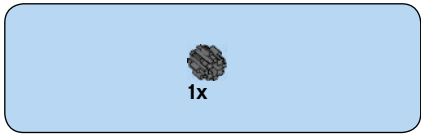

15

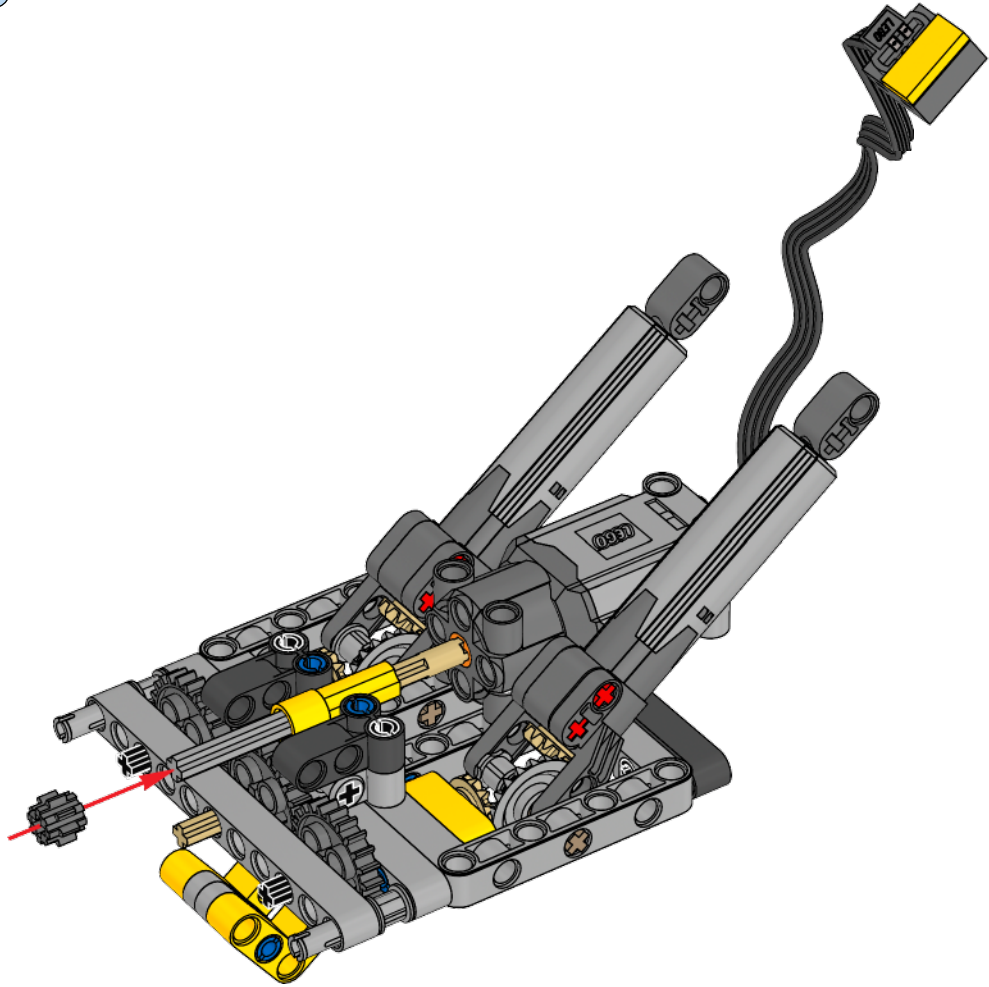

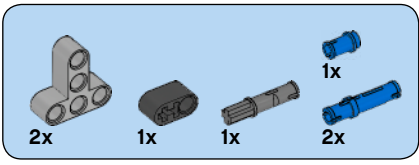

16

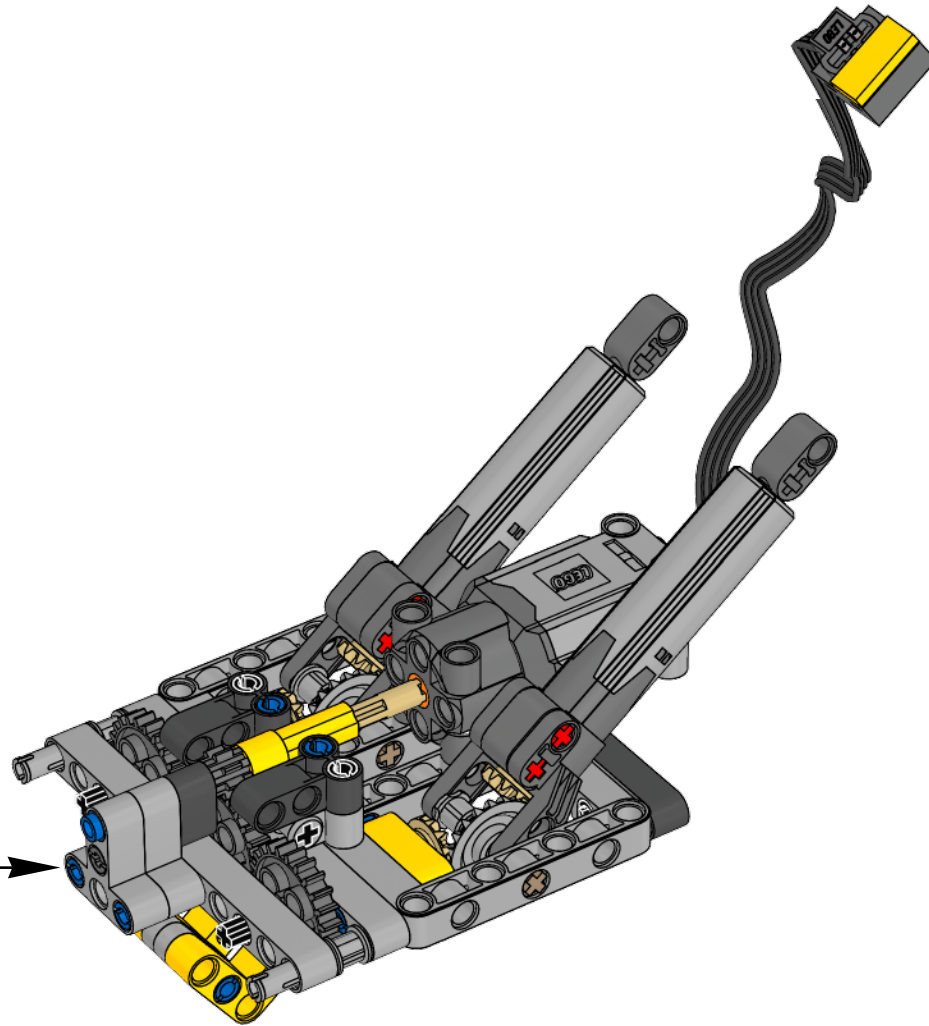
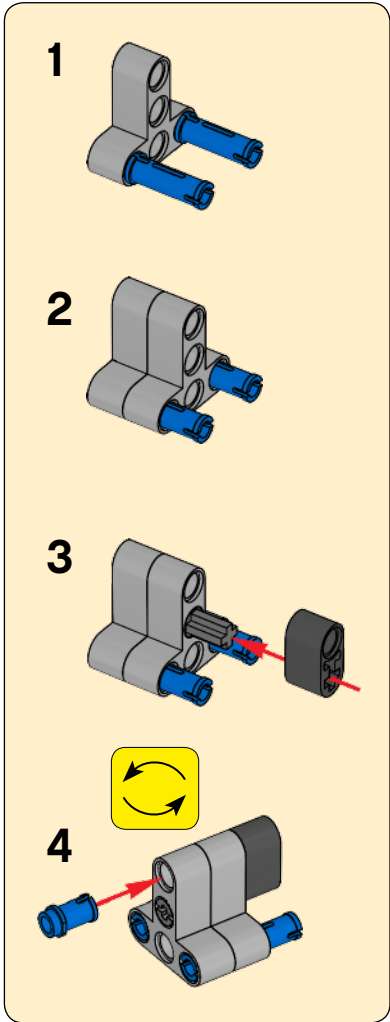

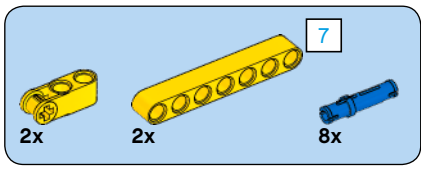

17

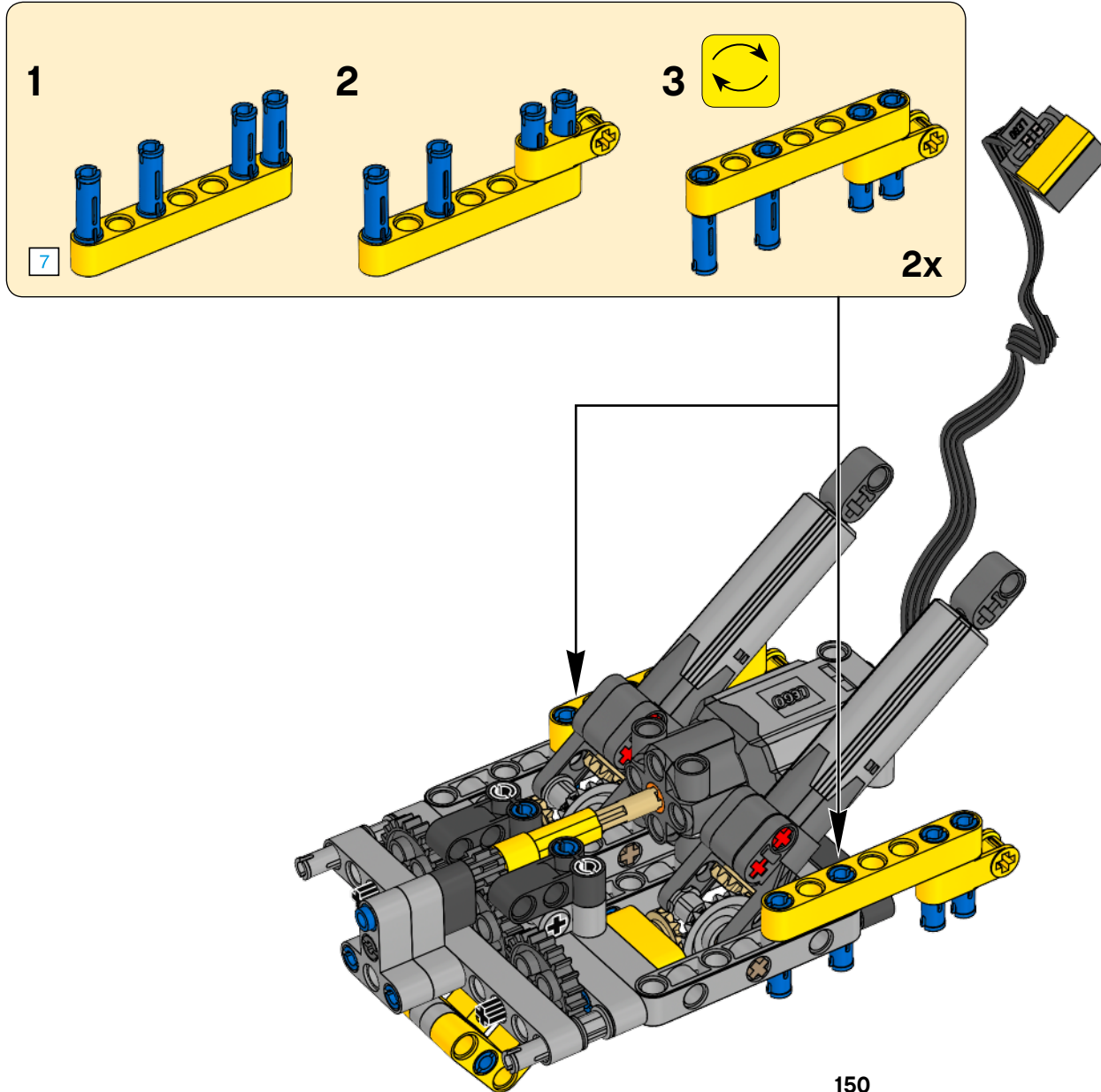

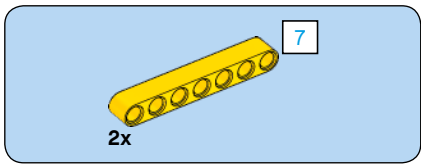

18

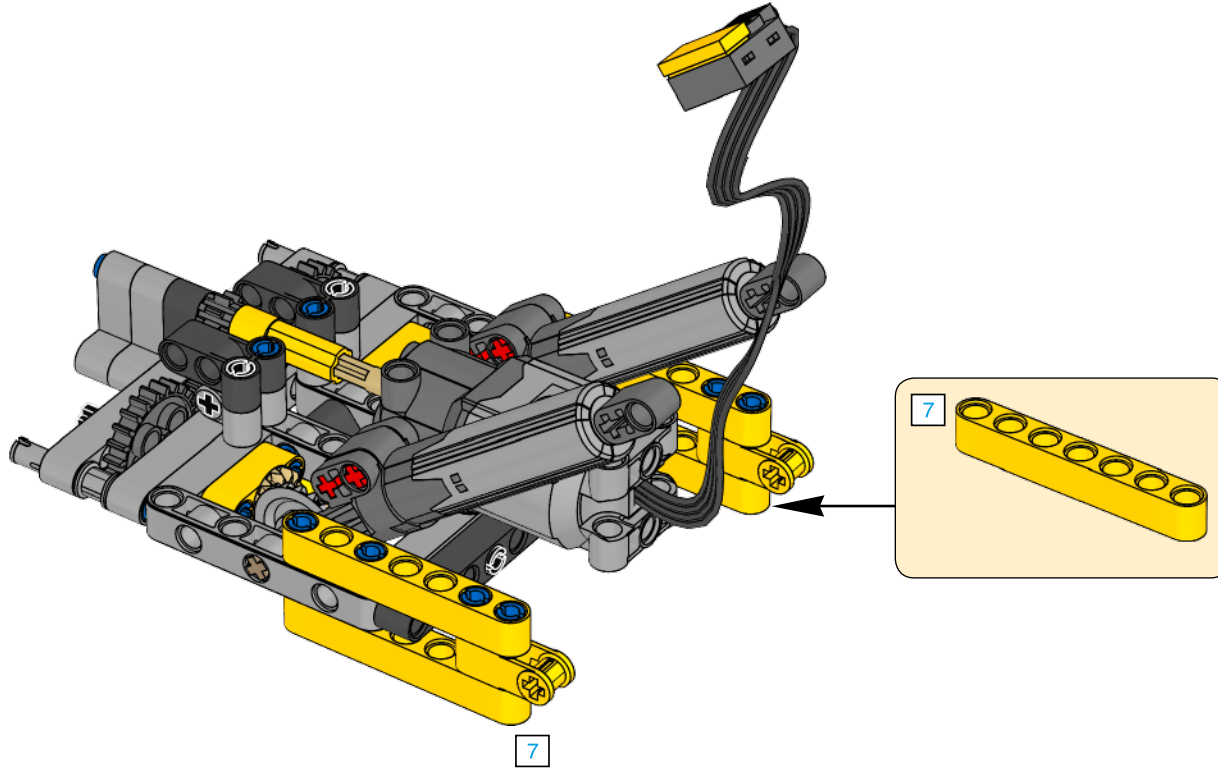

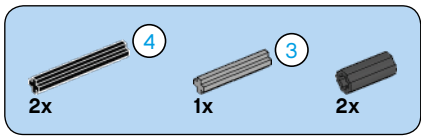

19

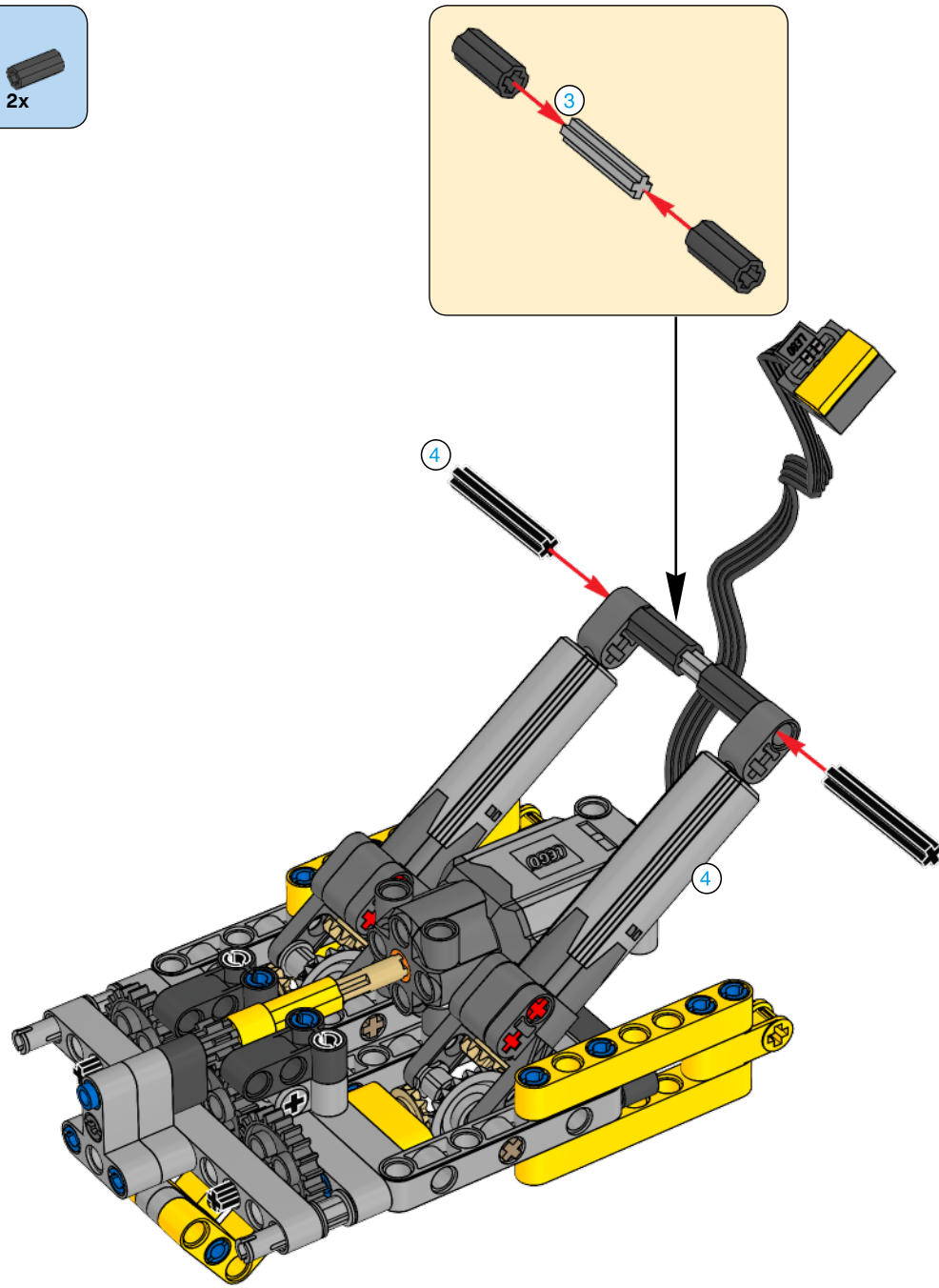

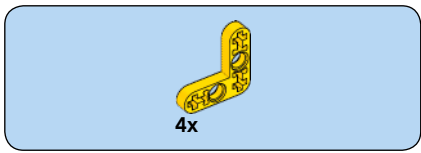

20

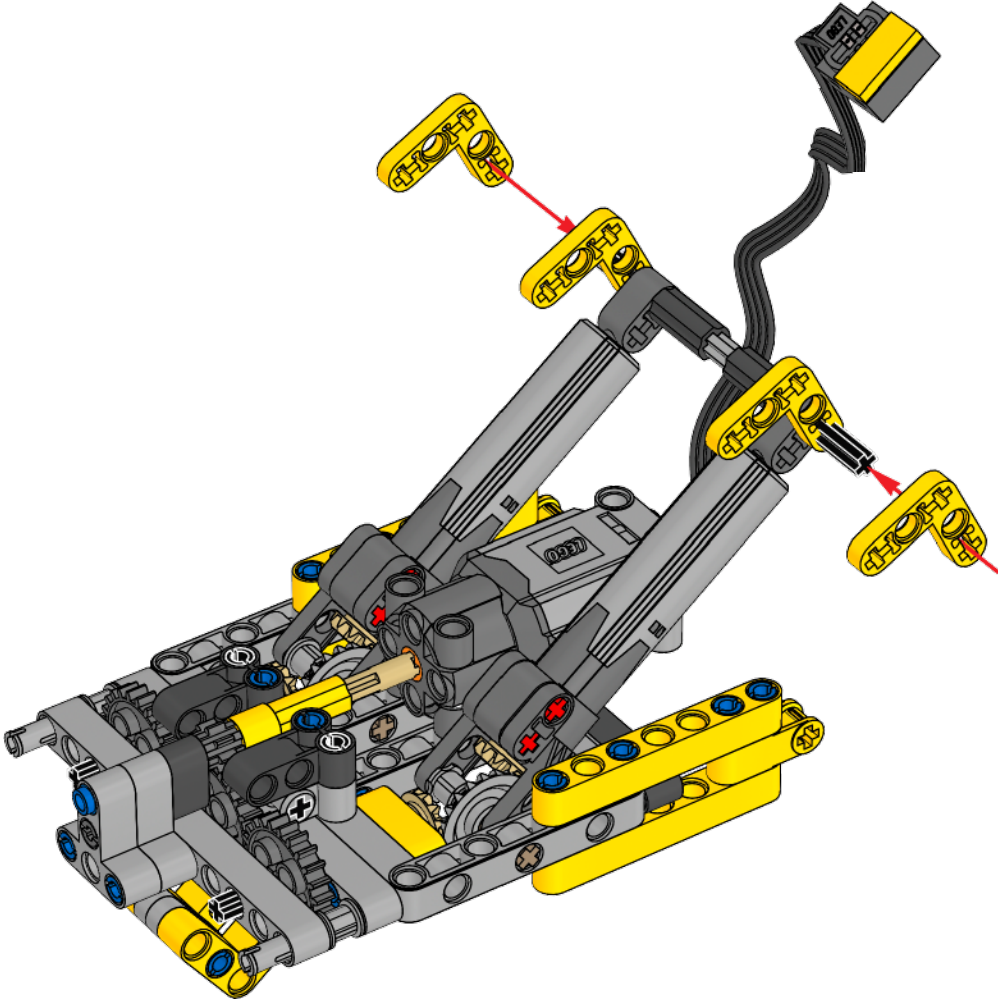

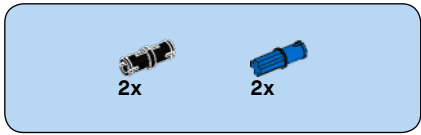

21

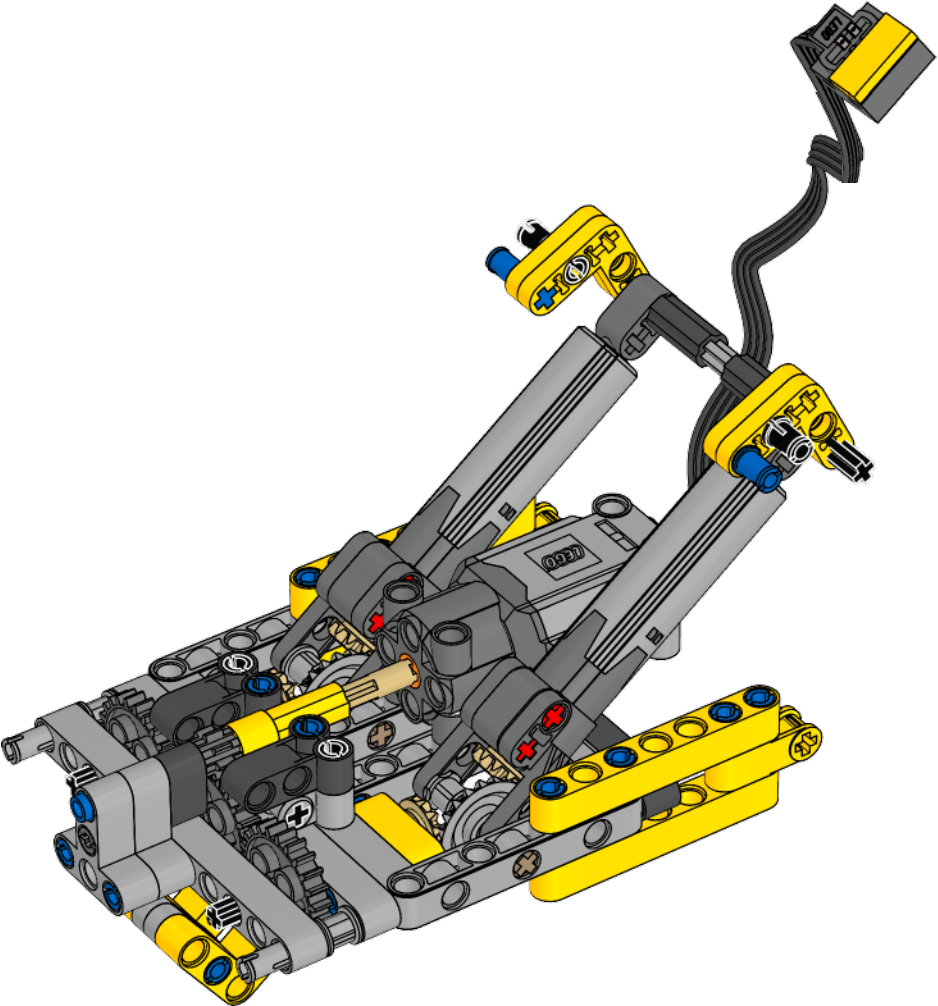

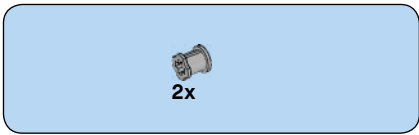

22

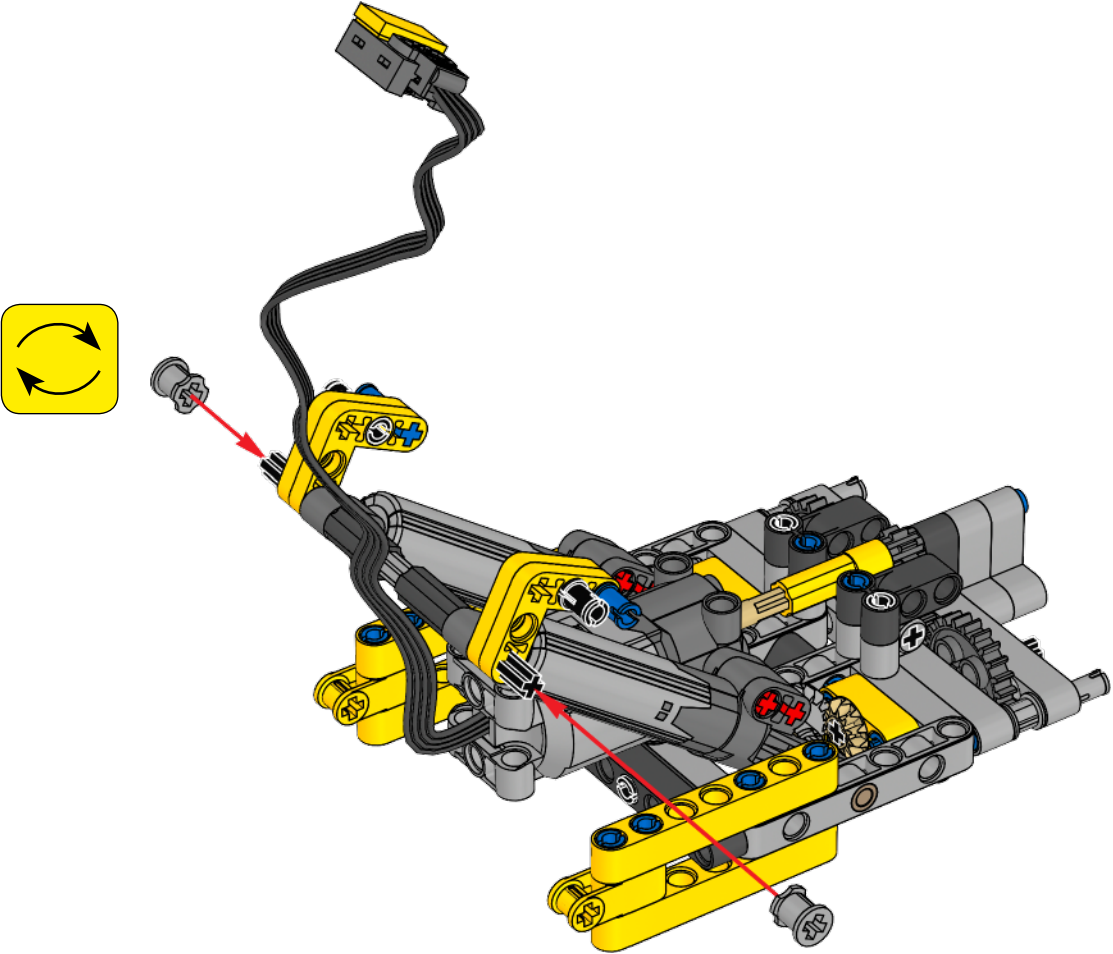

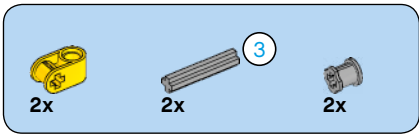

23

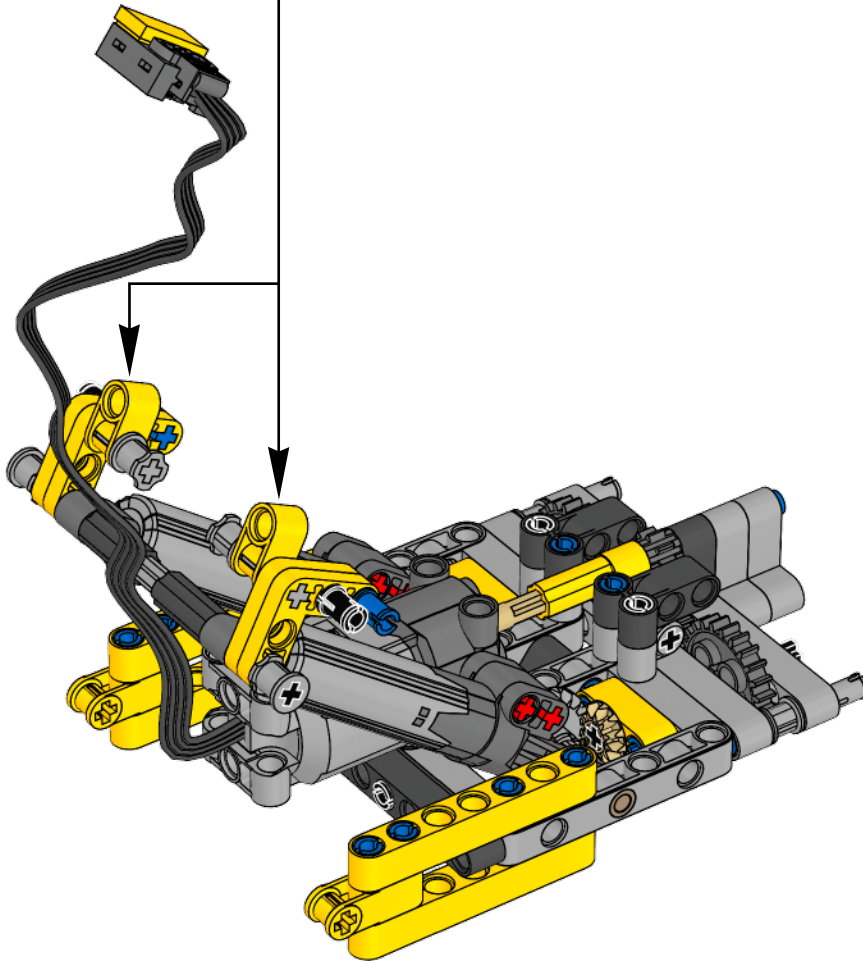
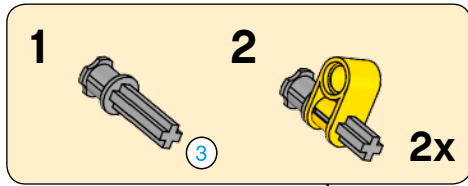

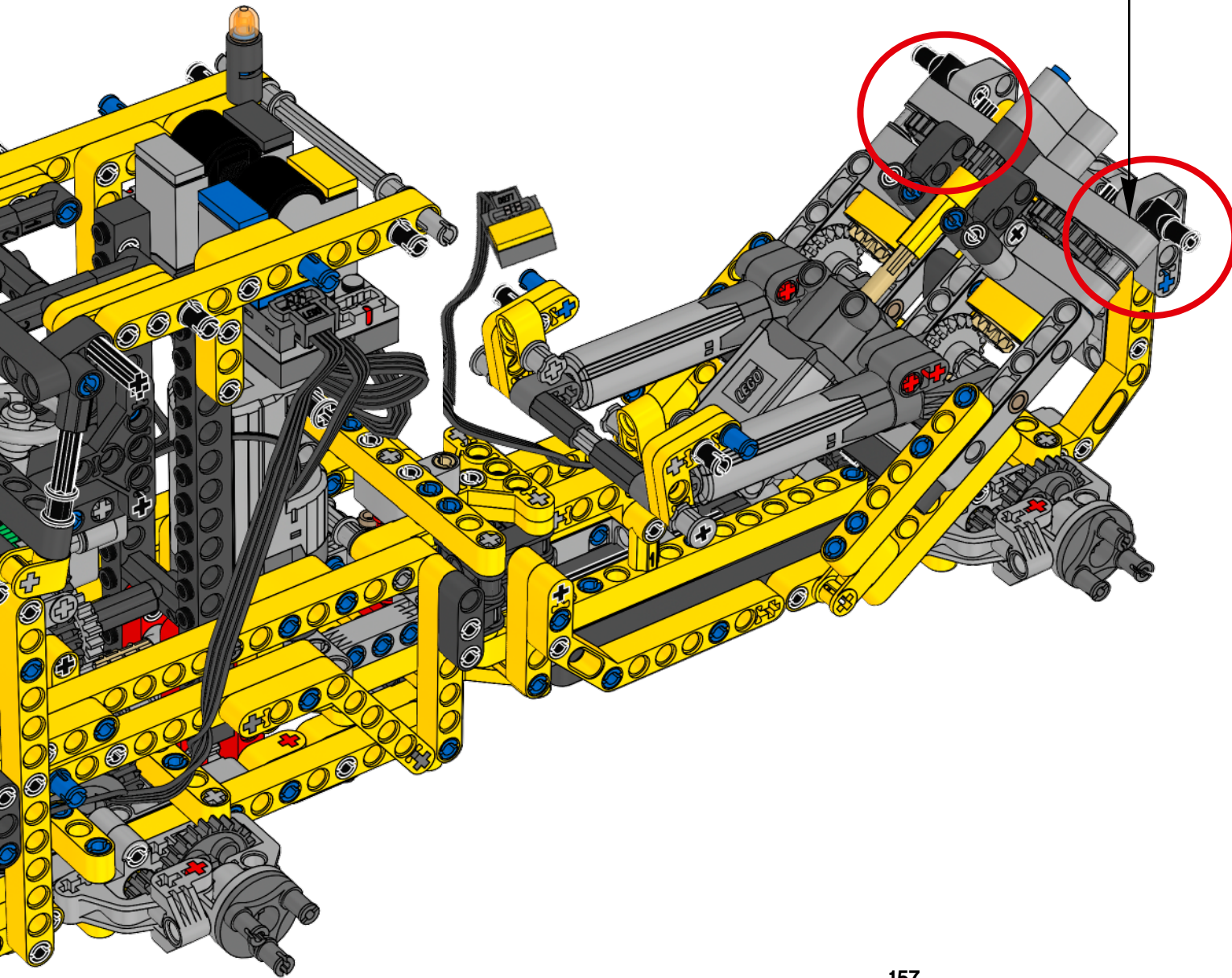

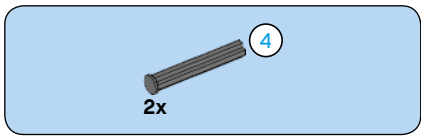

100

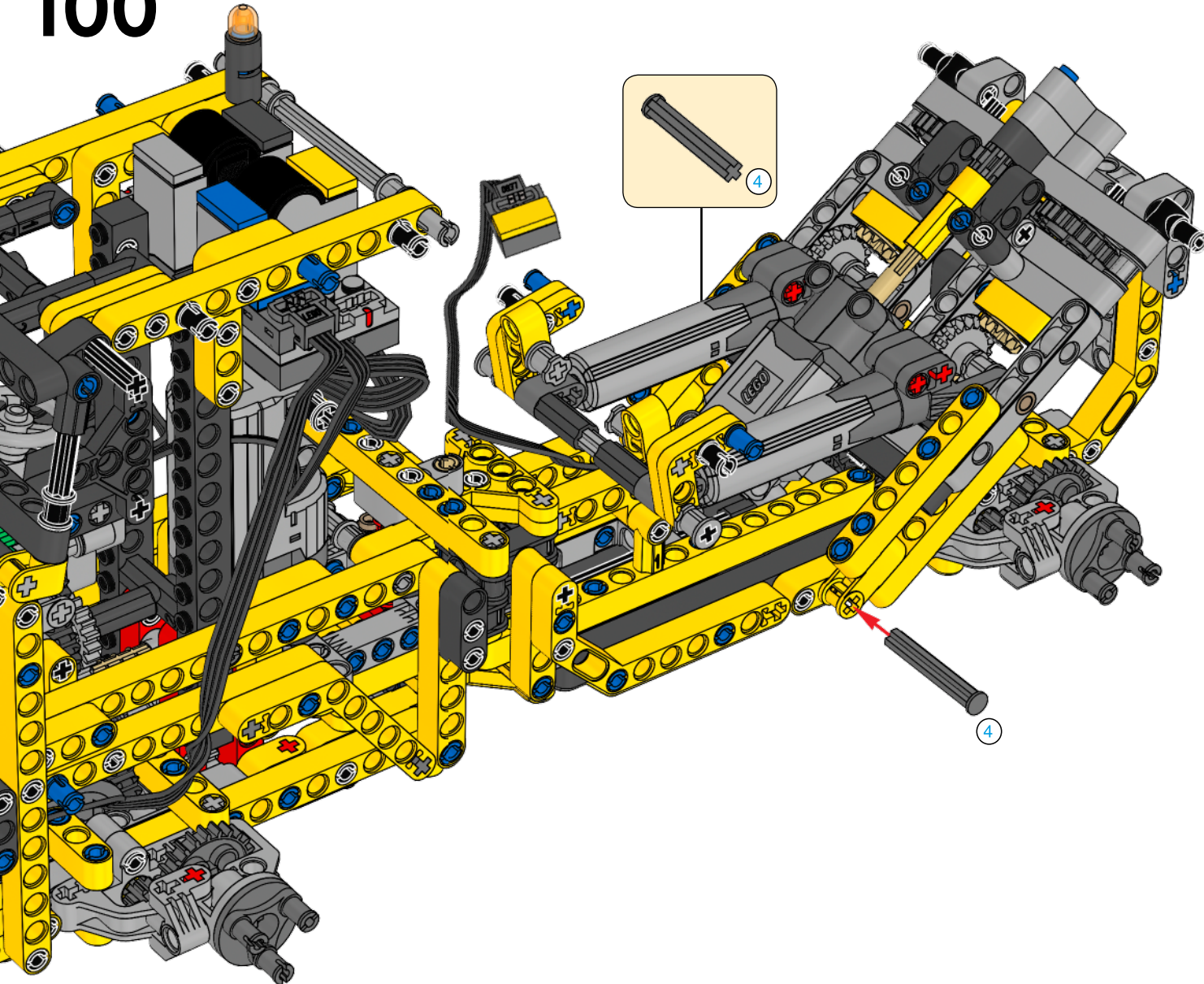

101

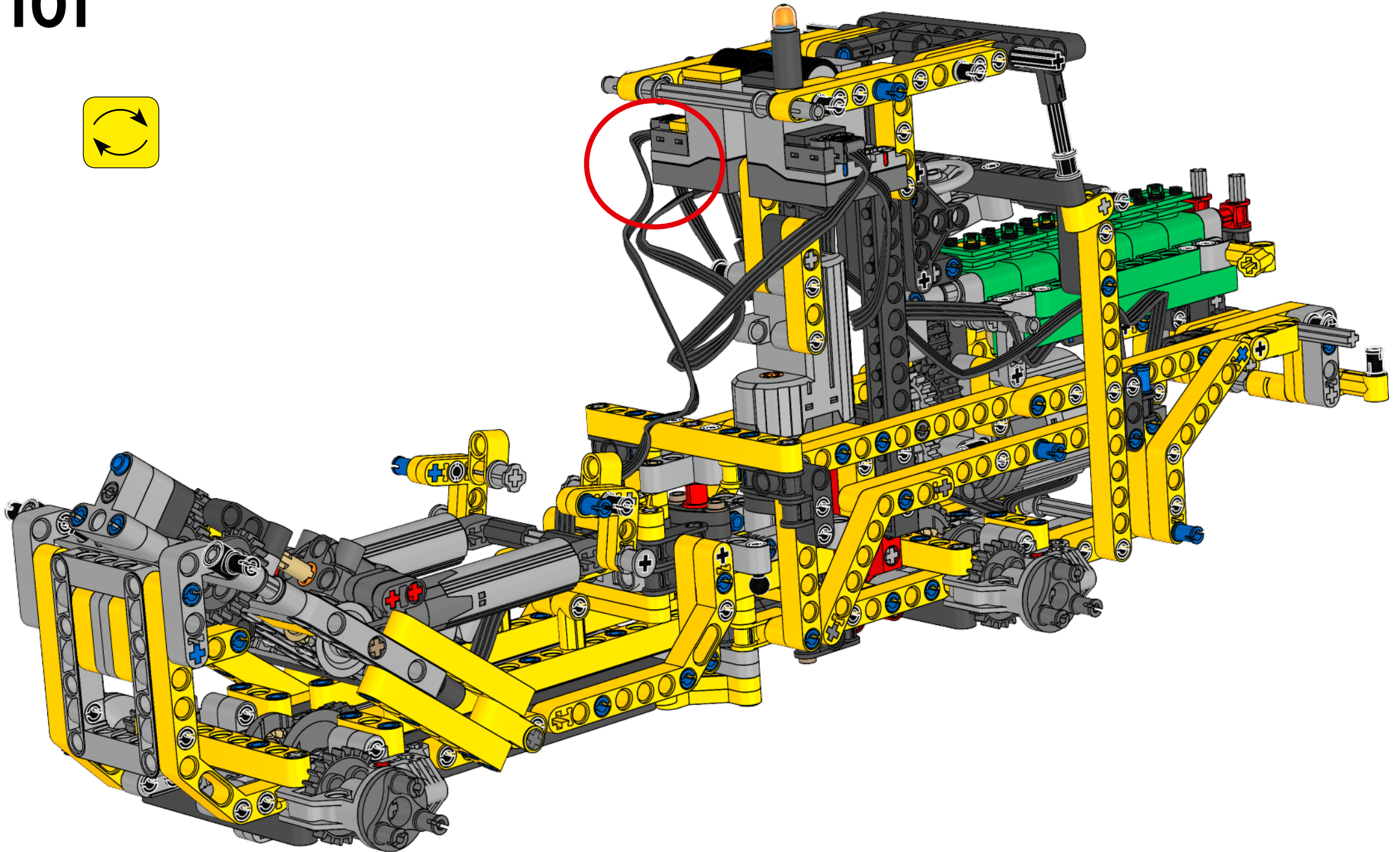

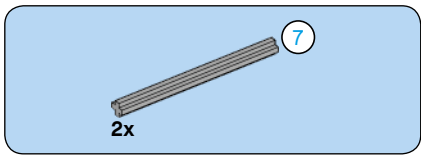

102

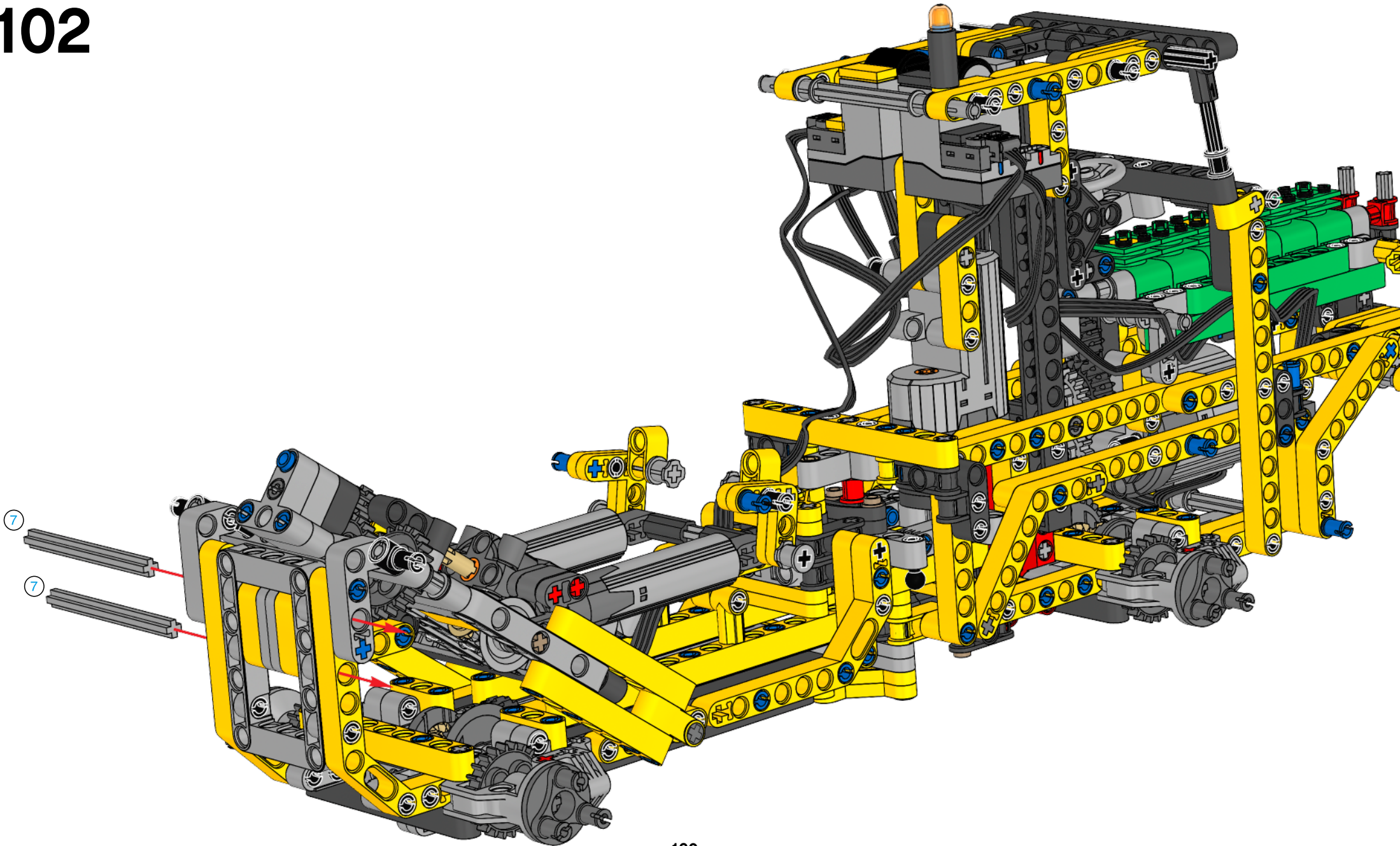

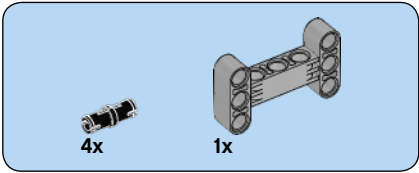
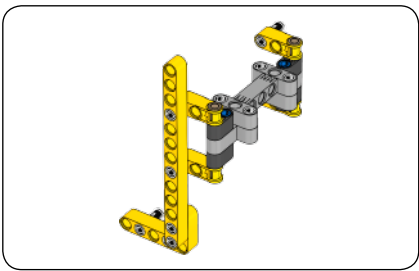

1

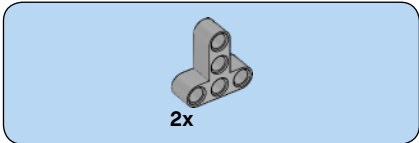
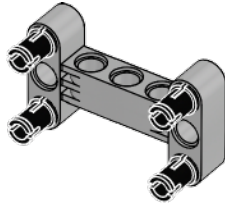

2

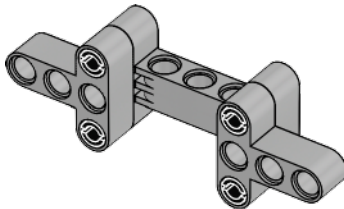

3

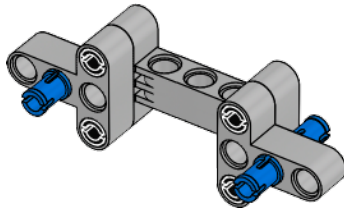

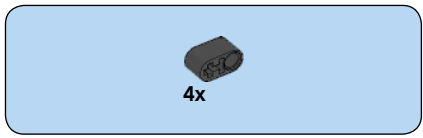

4

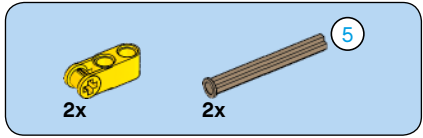
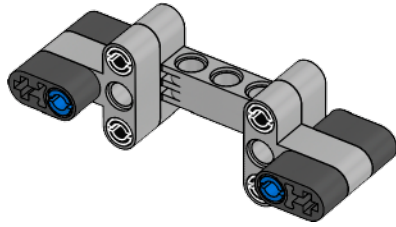

5

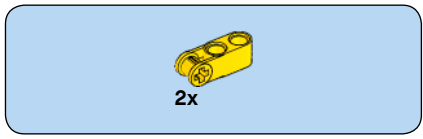
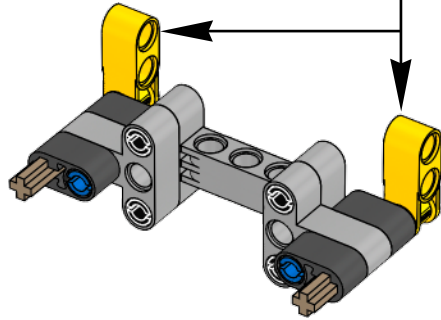
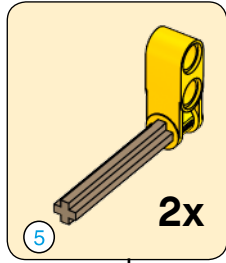

6

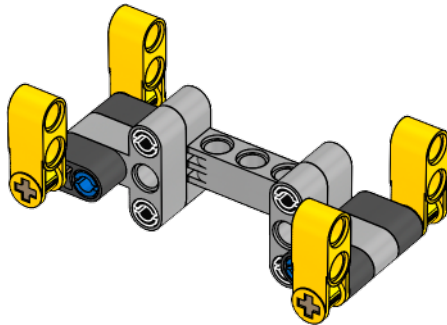



7

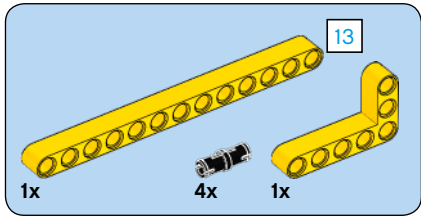
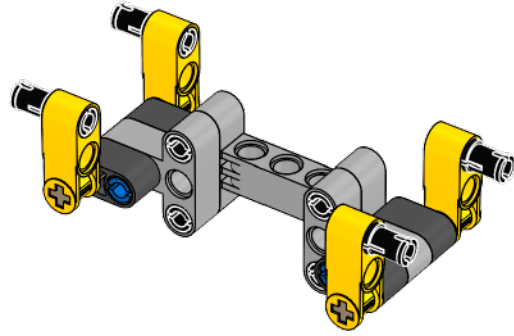

8

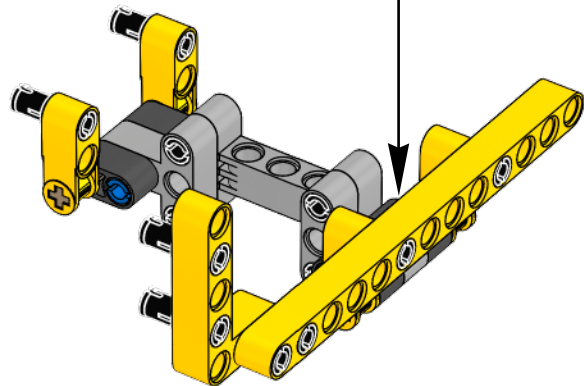
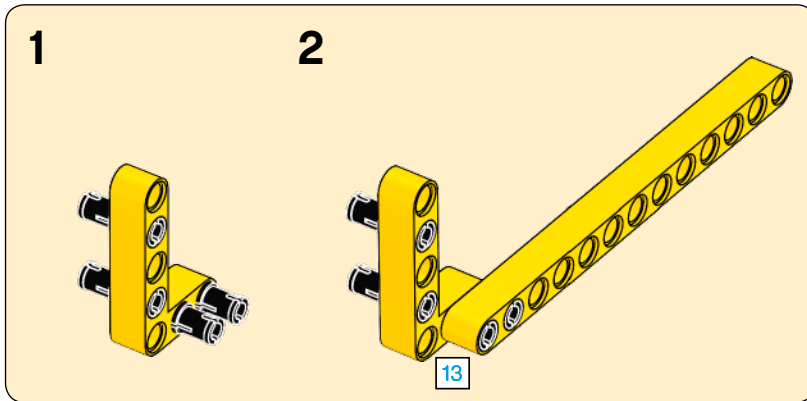

9

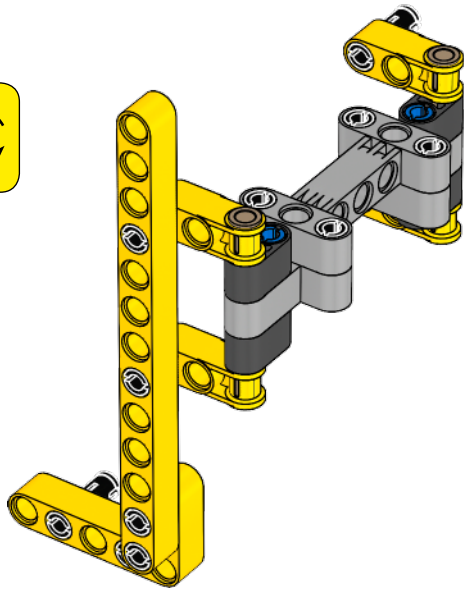
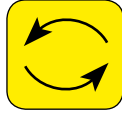

103

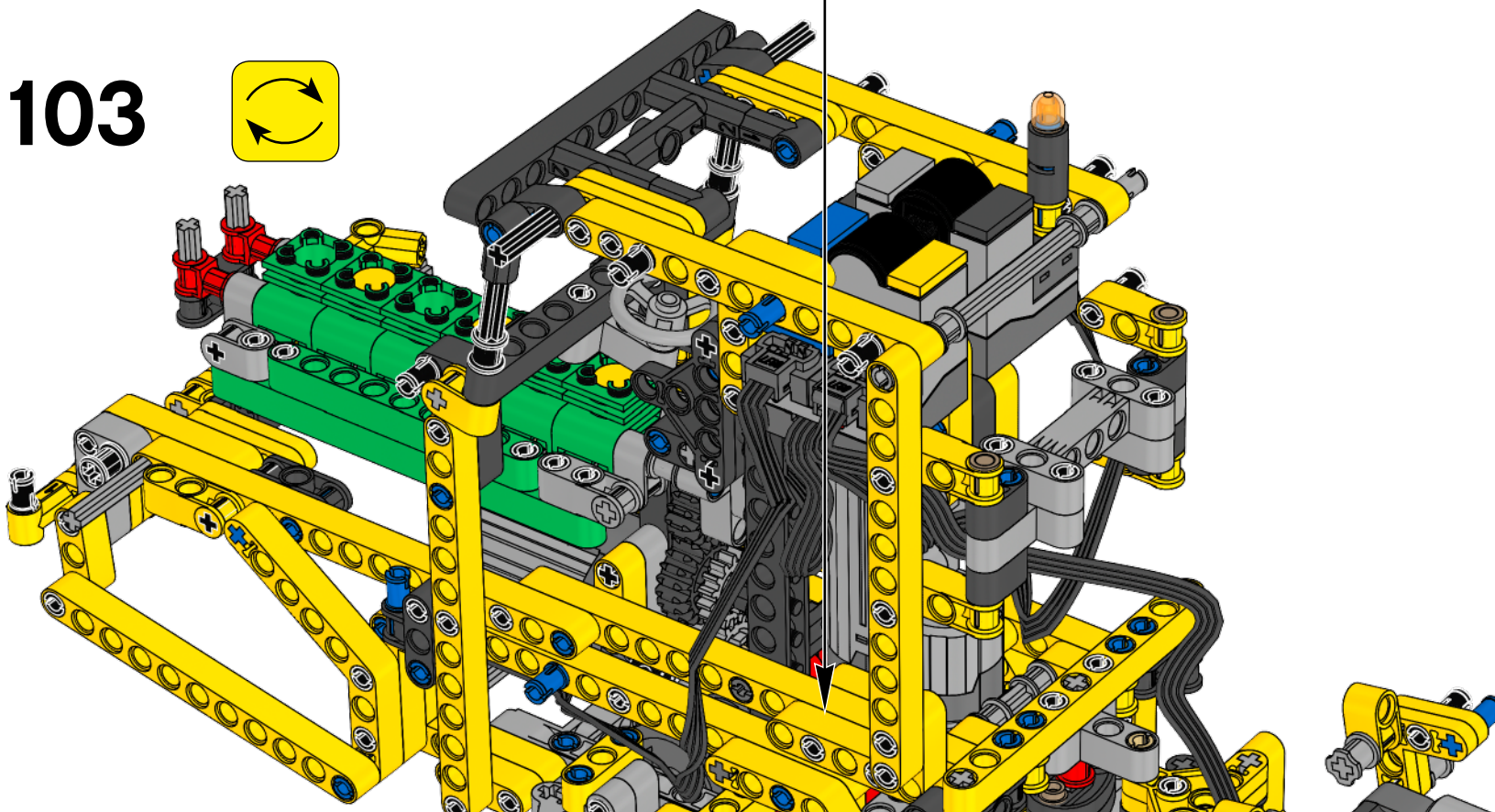

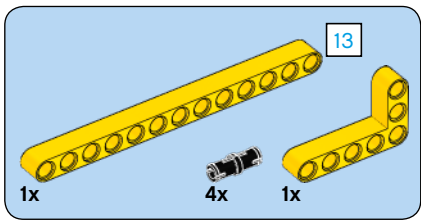

104

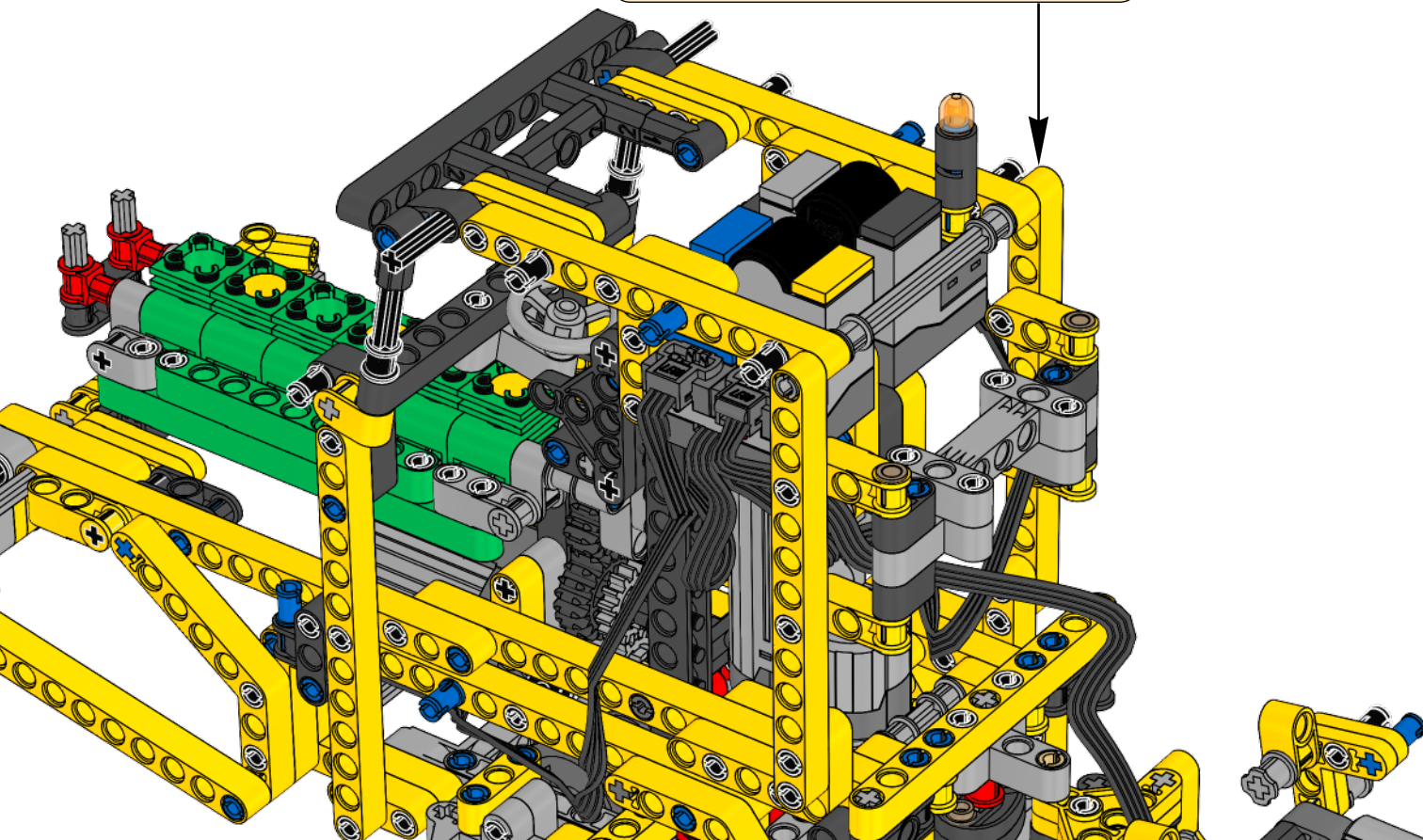
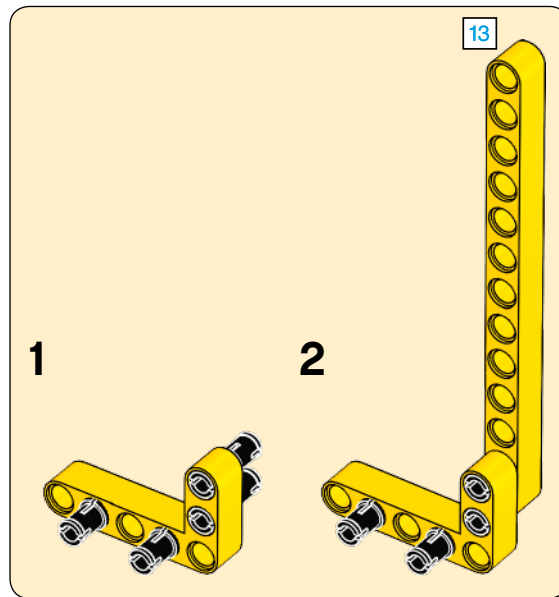

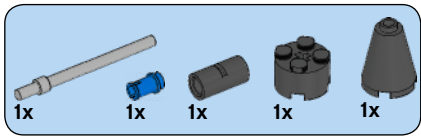

105

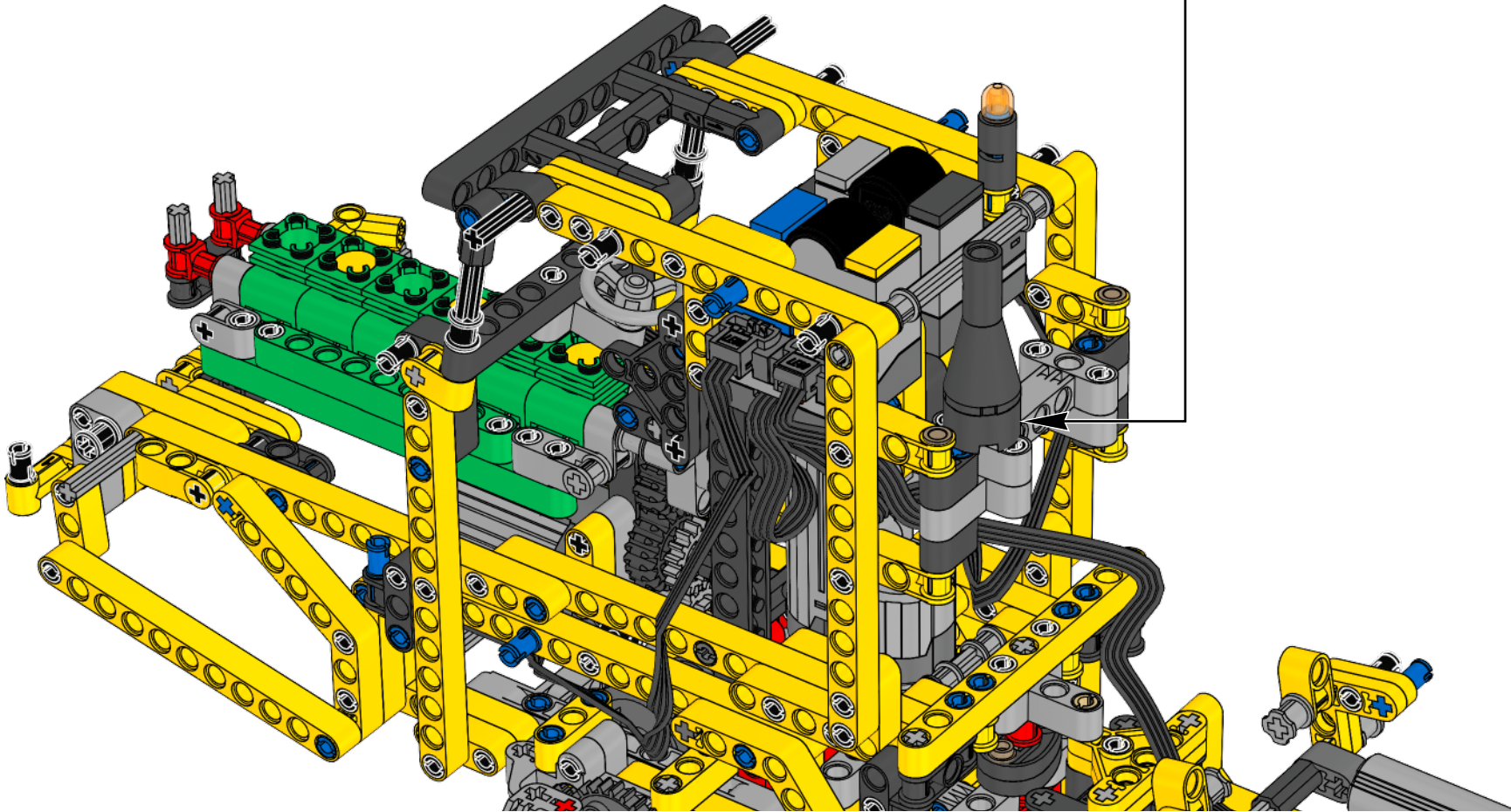
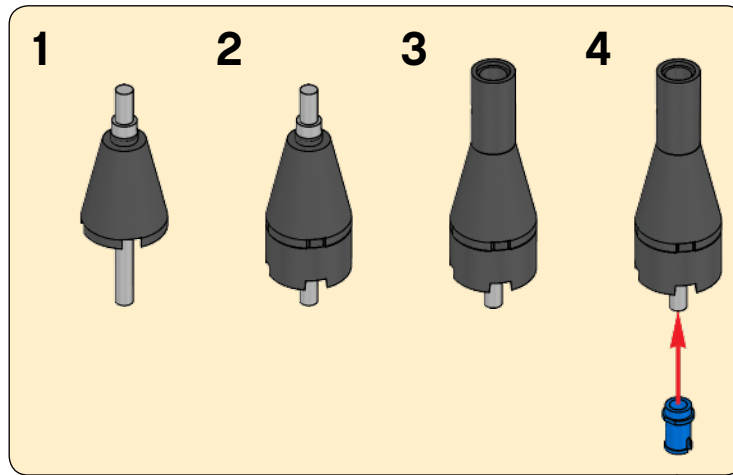

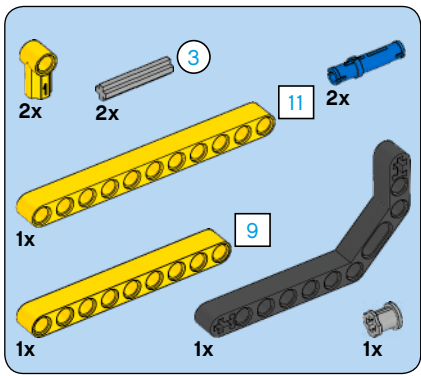

106

1

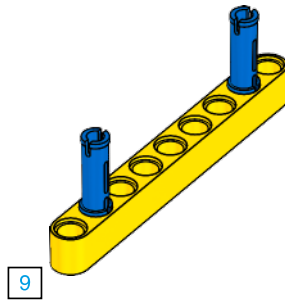

2

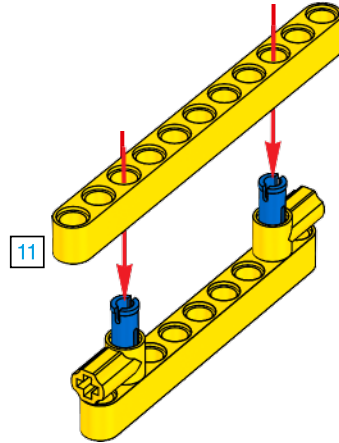

3

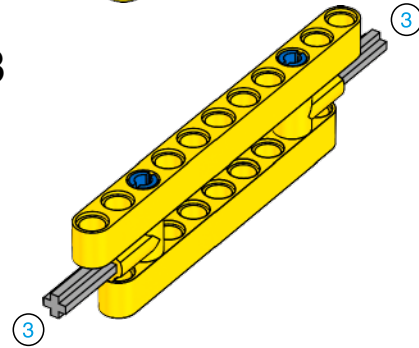

4

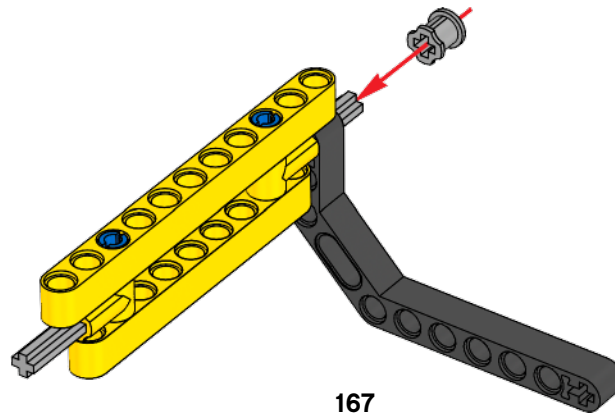

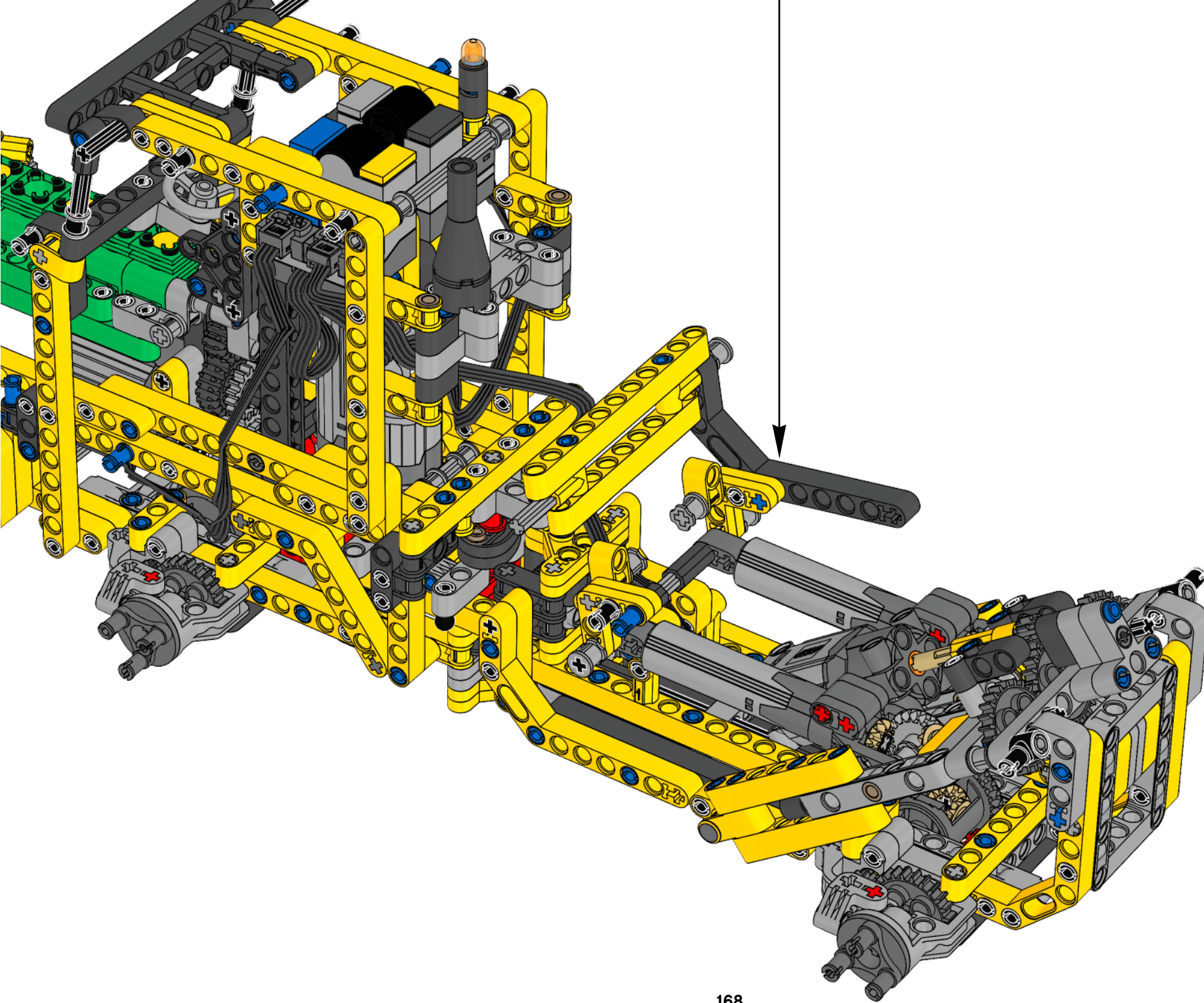

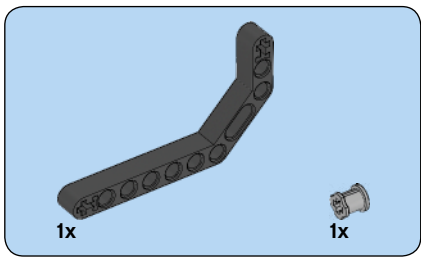

107

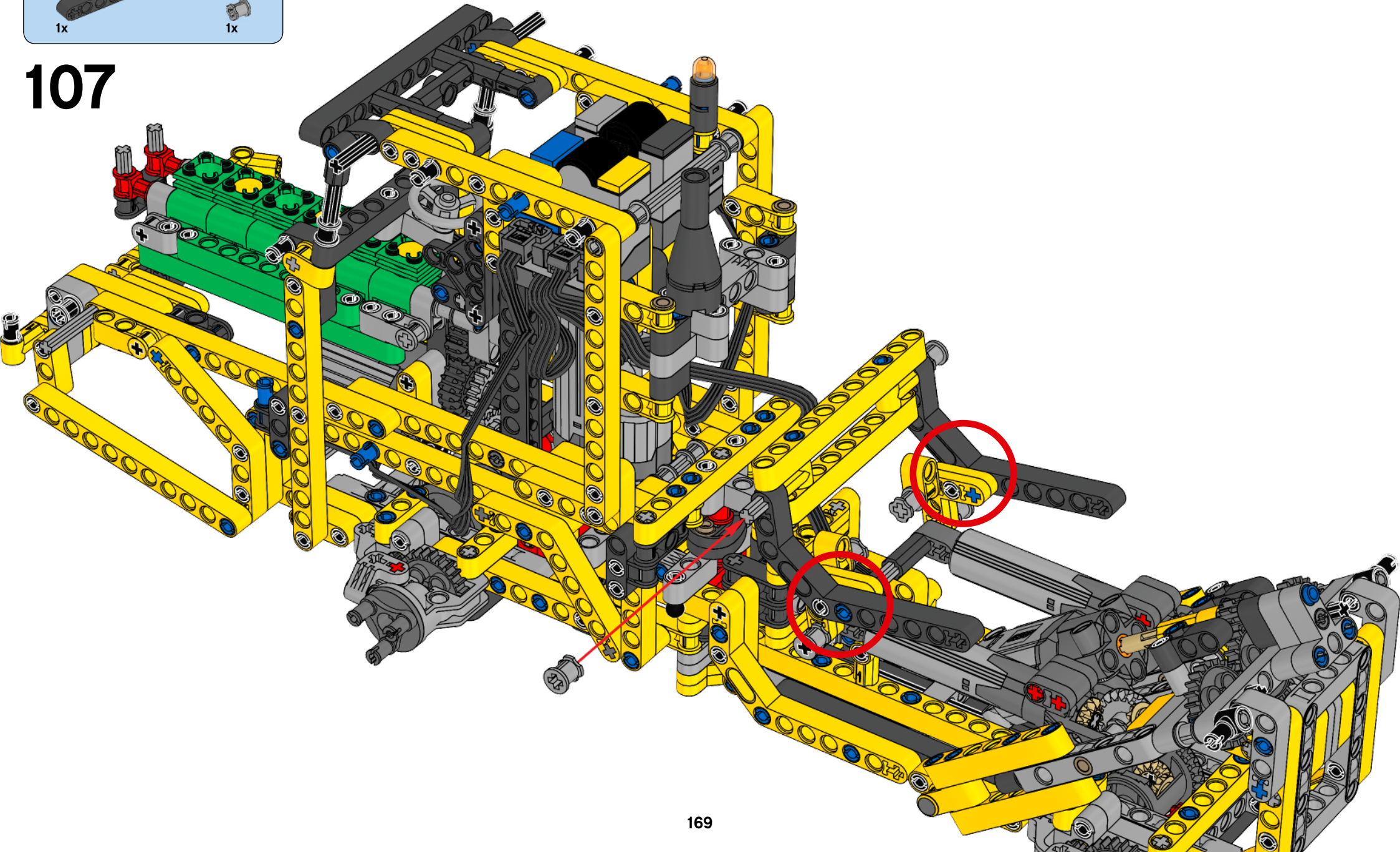

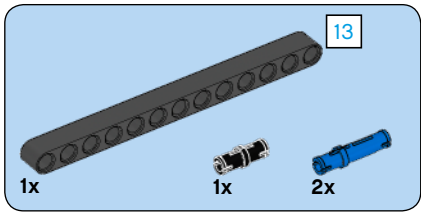
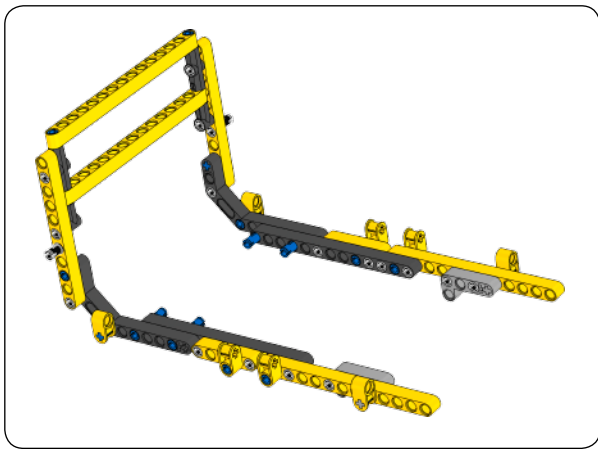

1

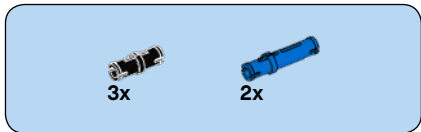
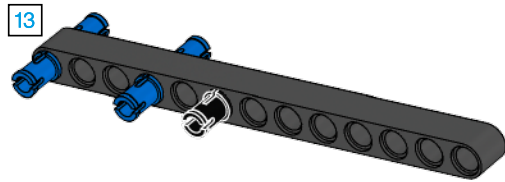

2

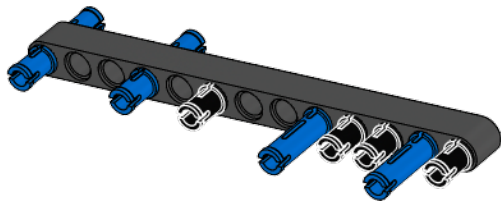

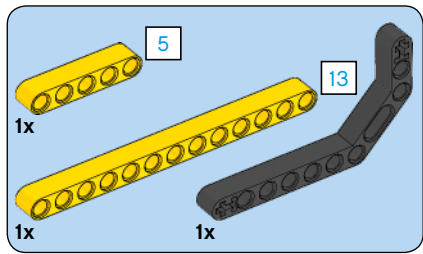

3

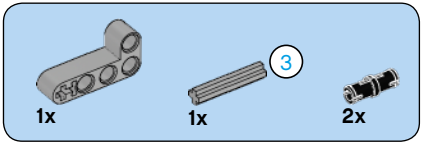
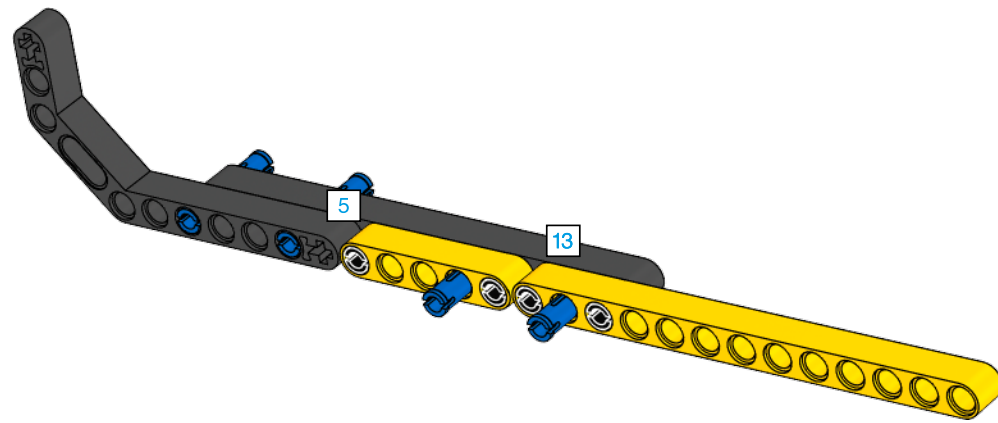

4

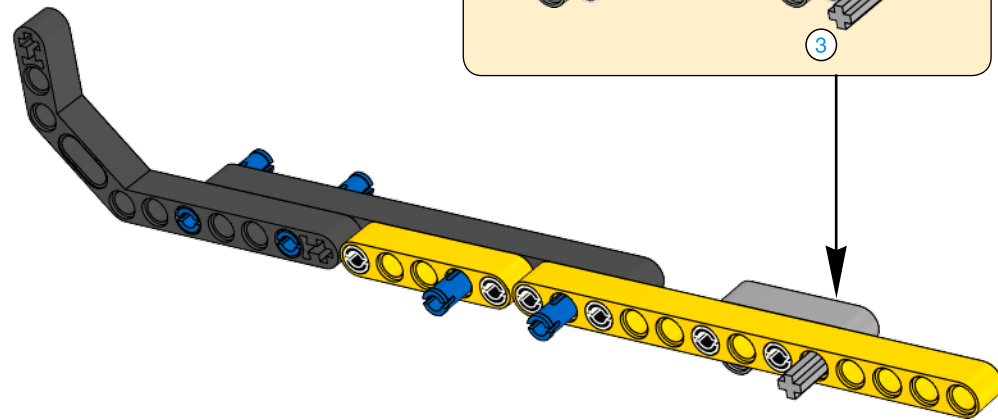
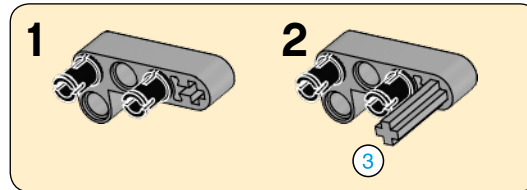

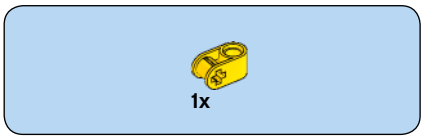

5

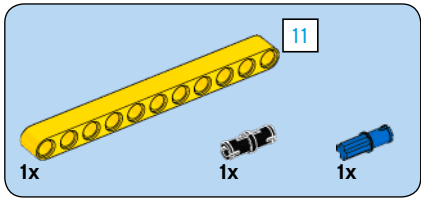
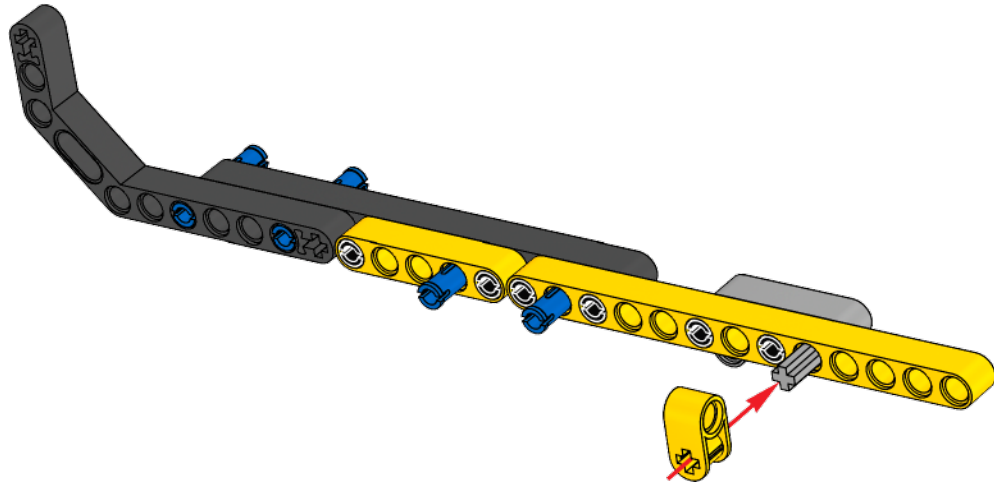

6

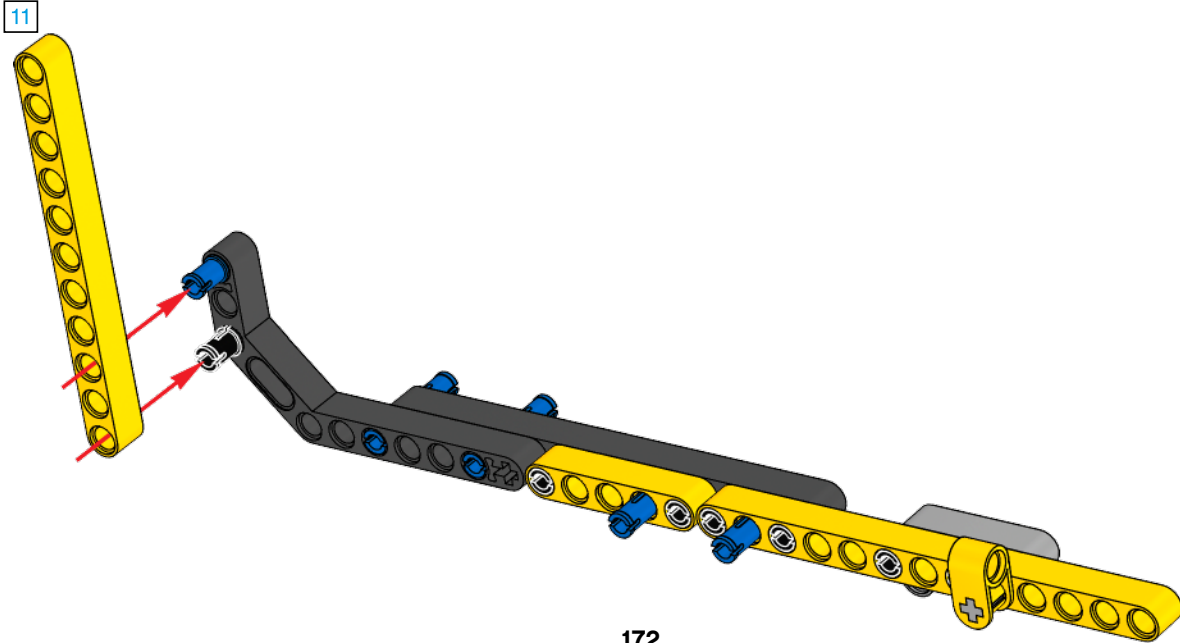

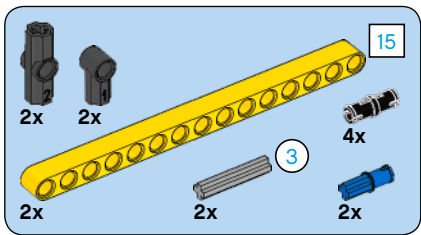

7

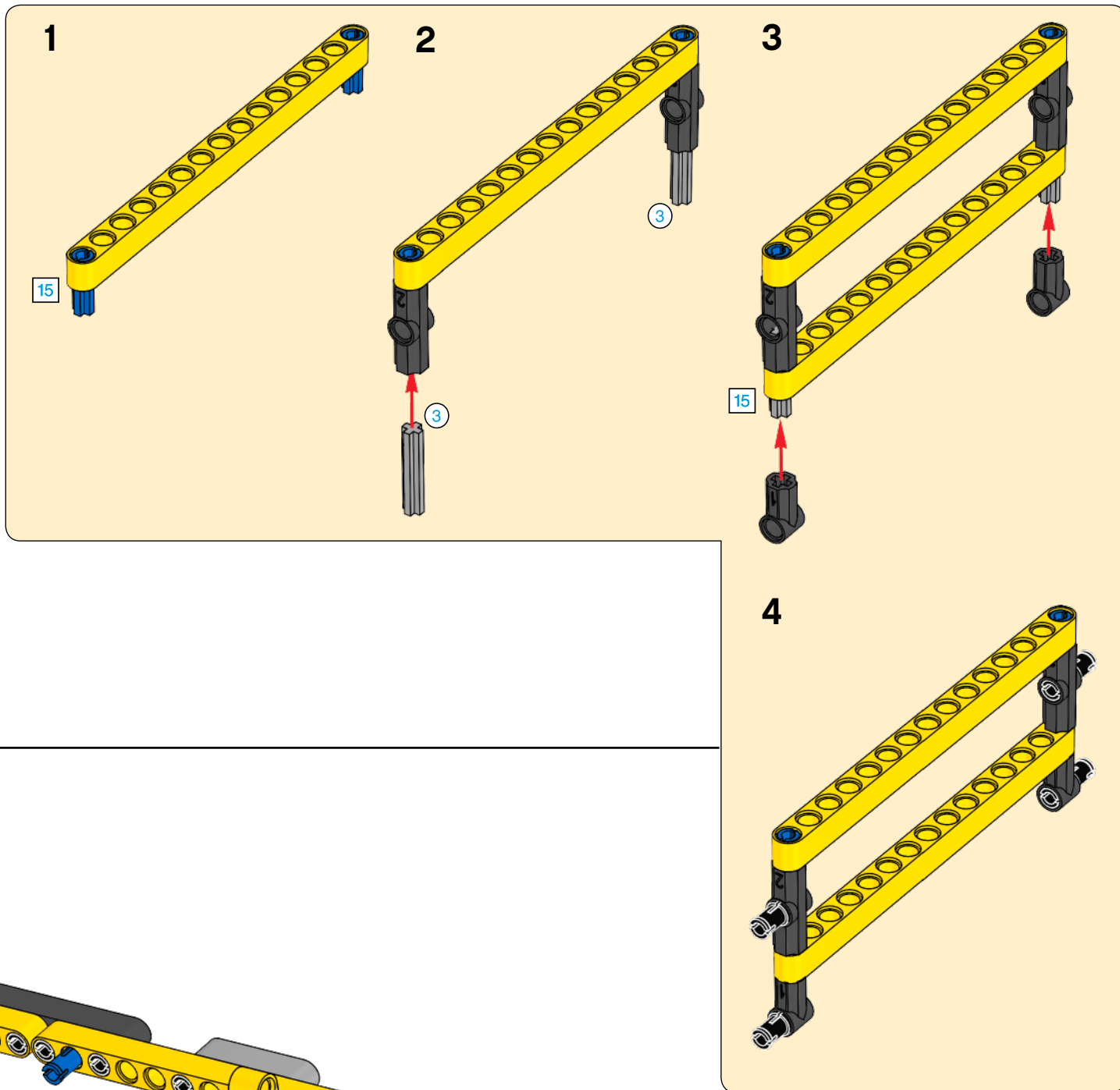
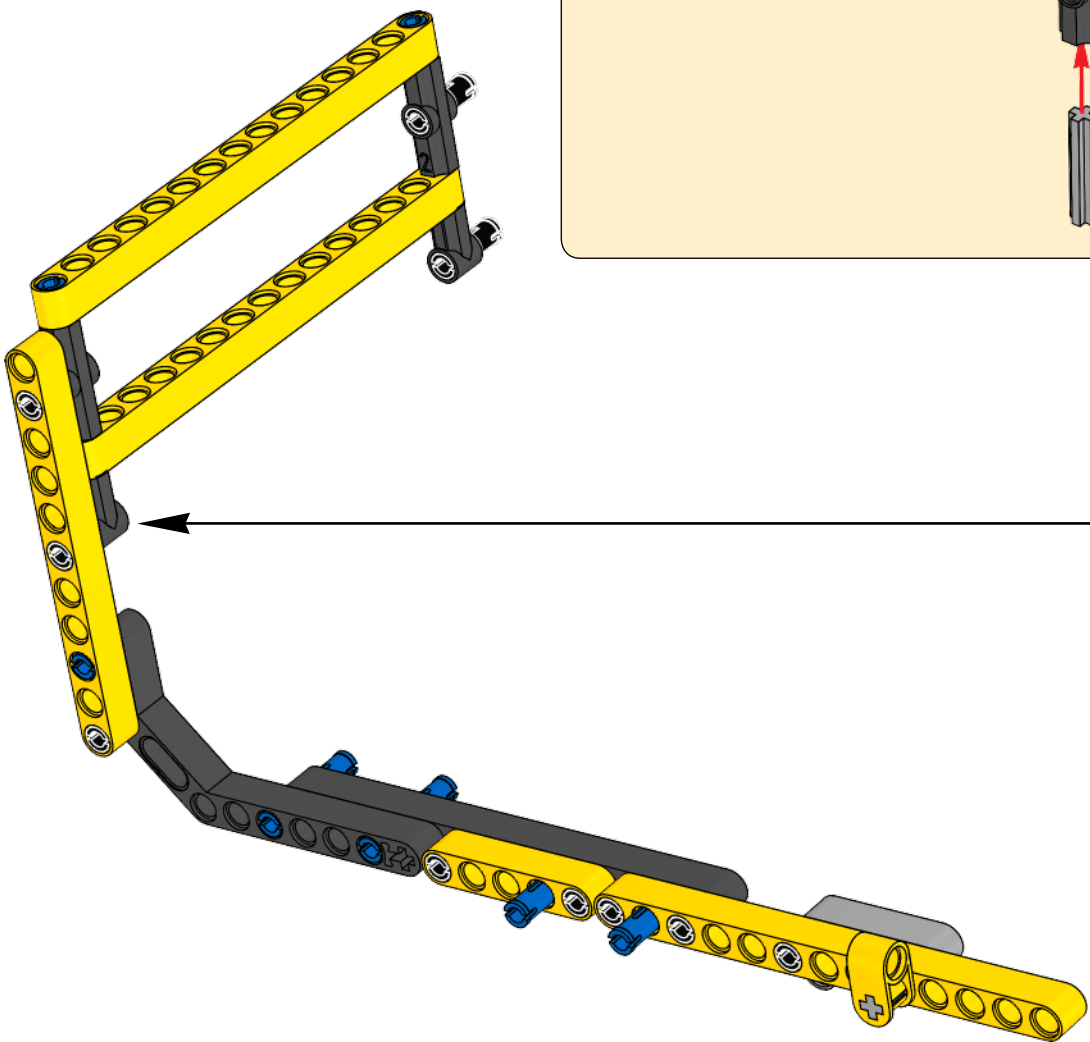

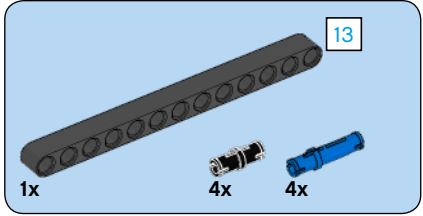
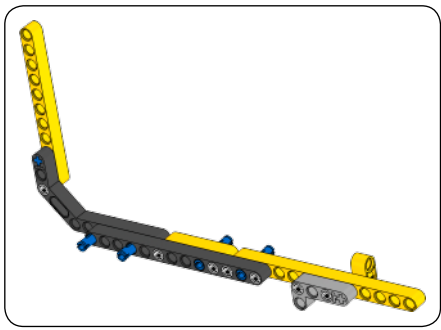

1

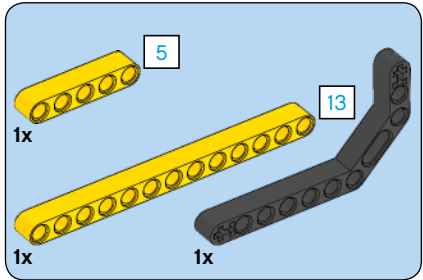
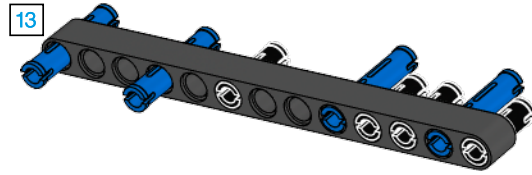

2

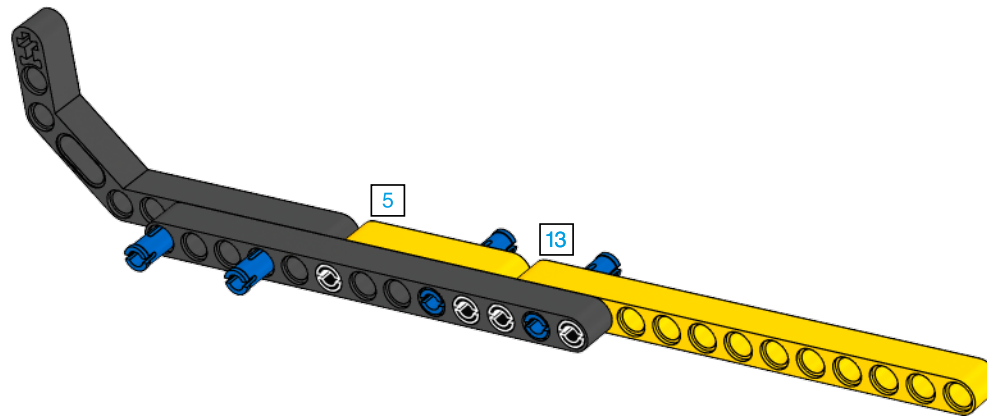

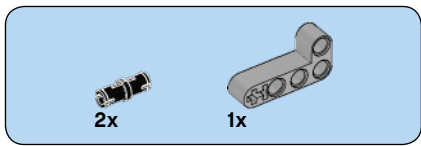

3

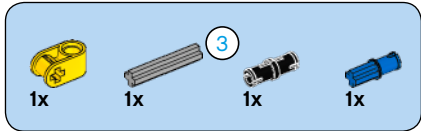
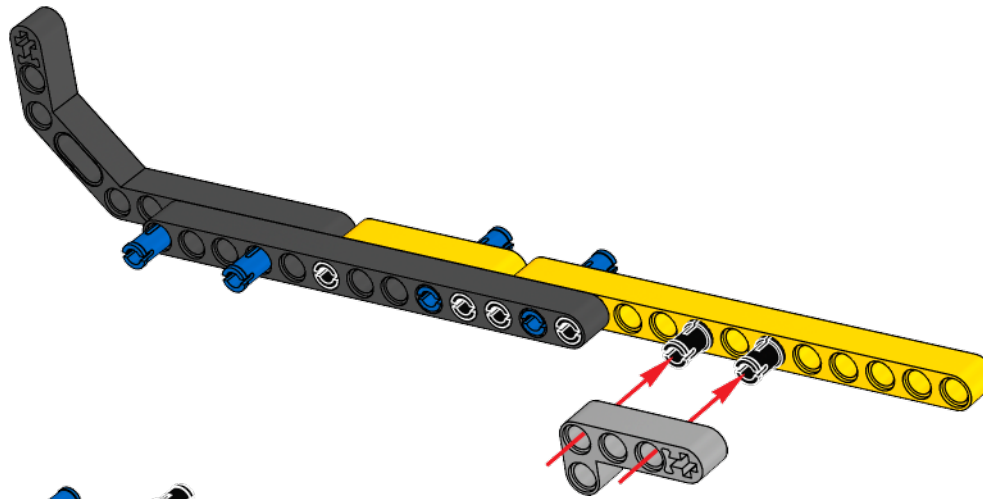

4

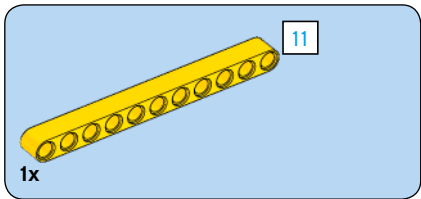
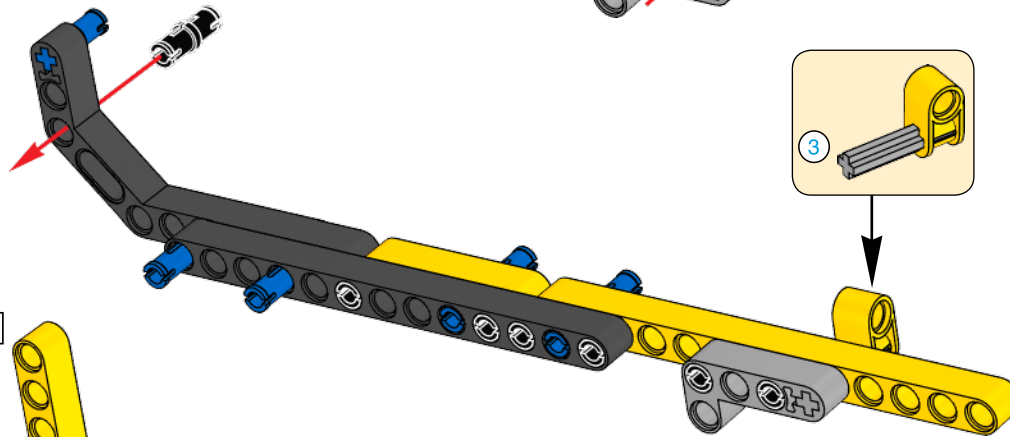

5

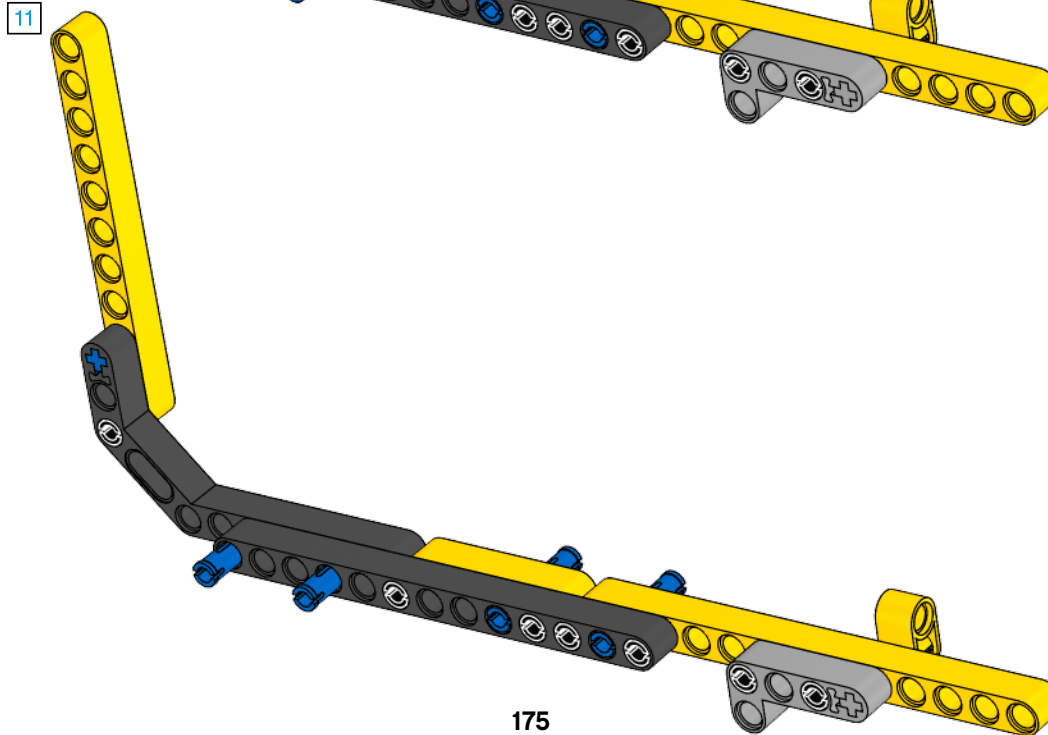

8

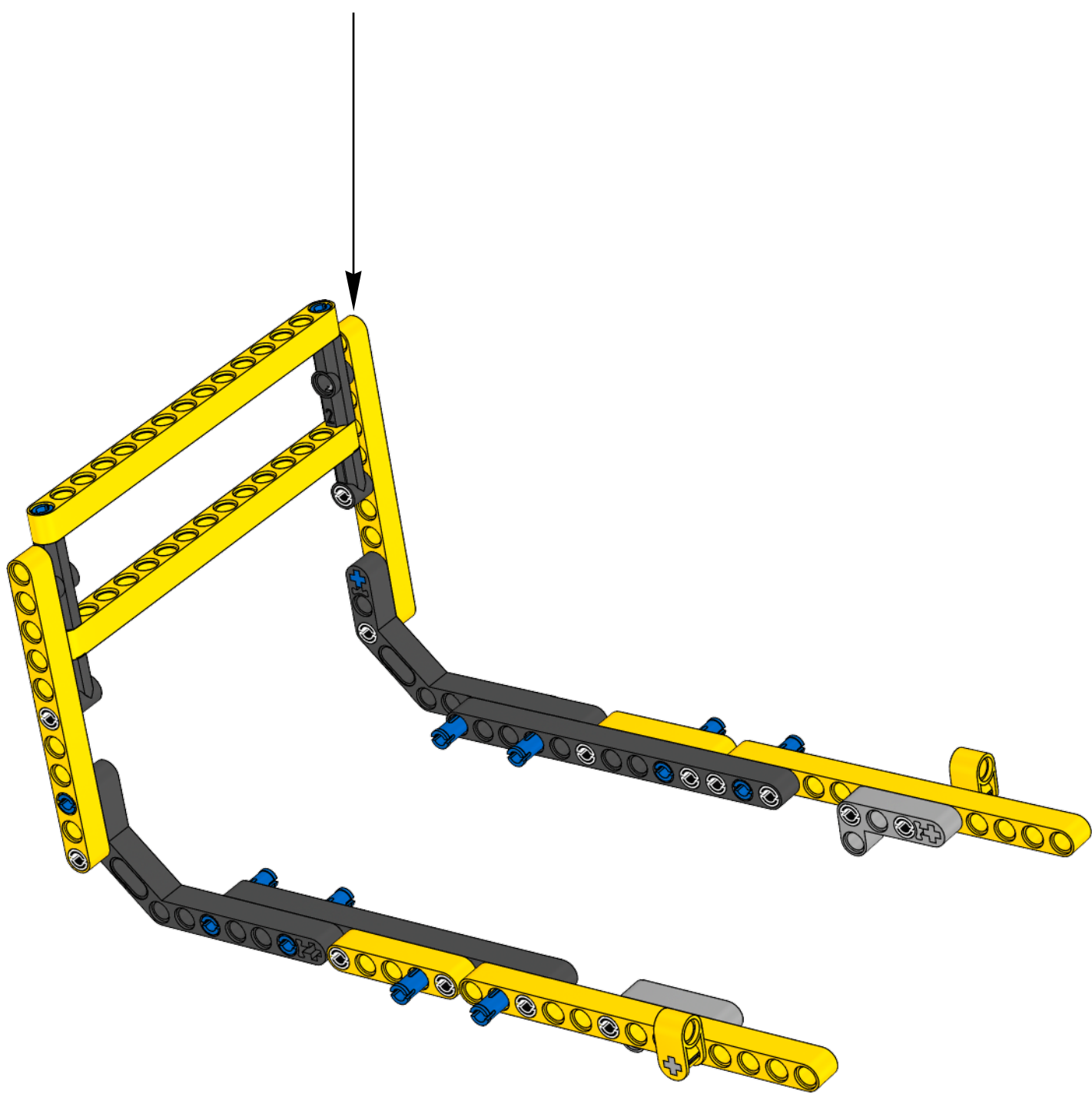

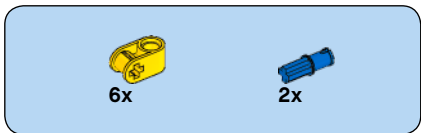

9

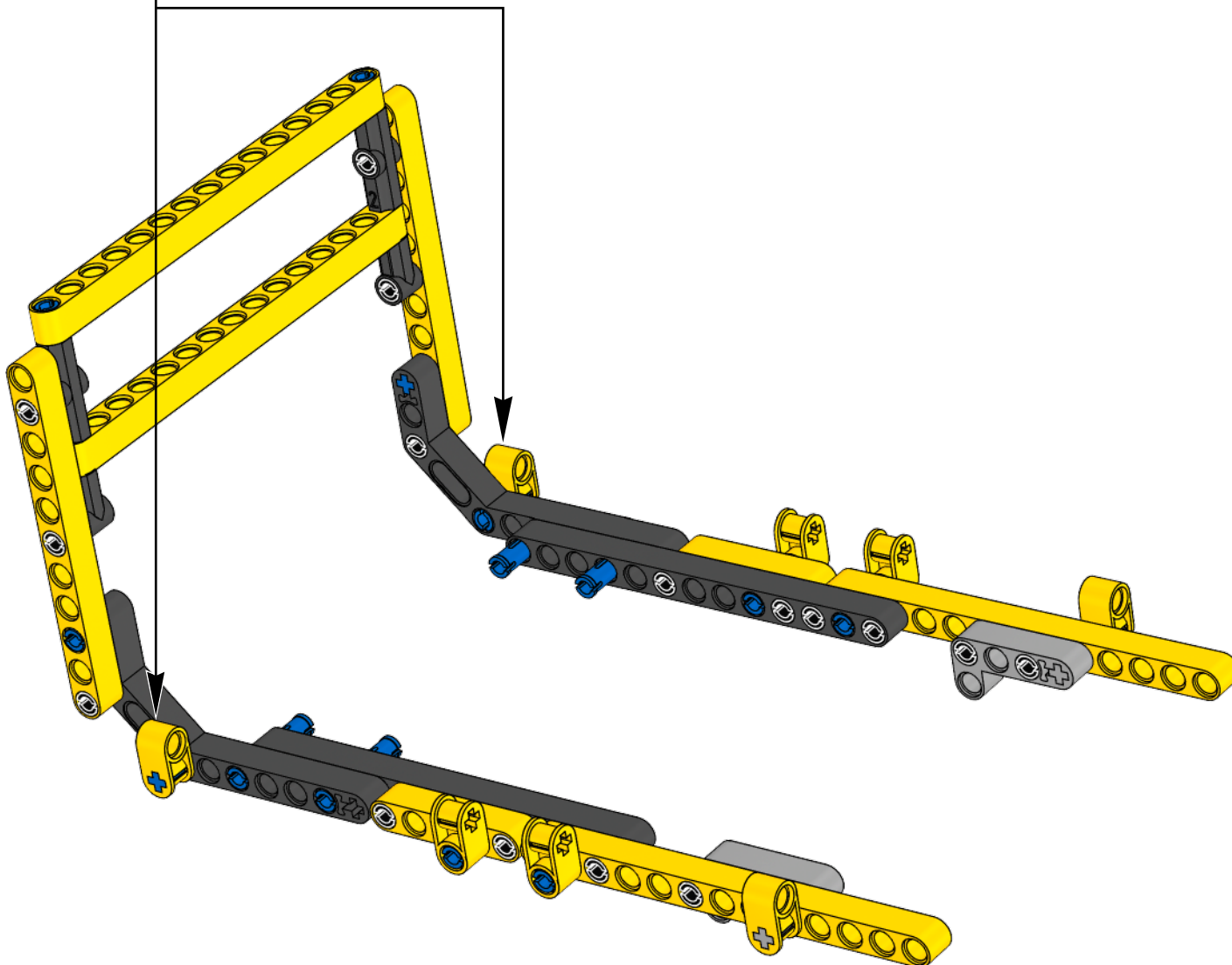

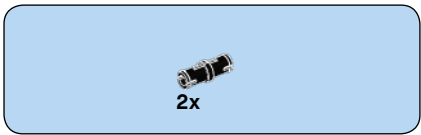

10

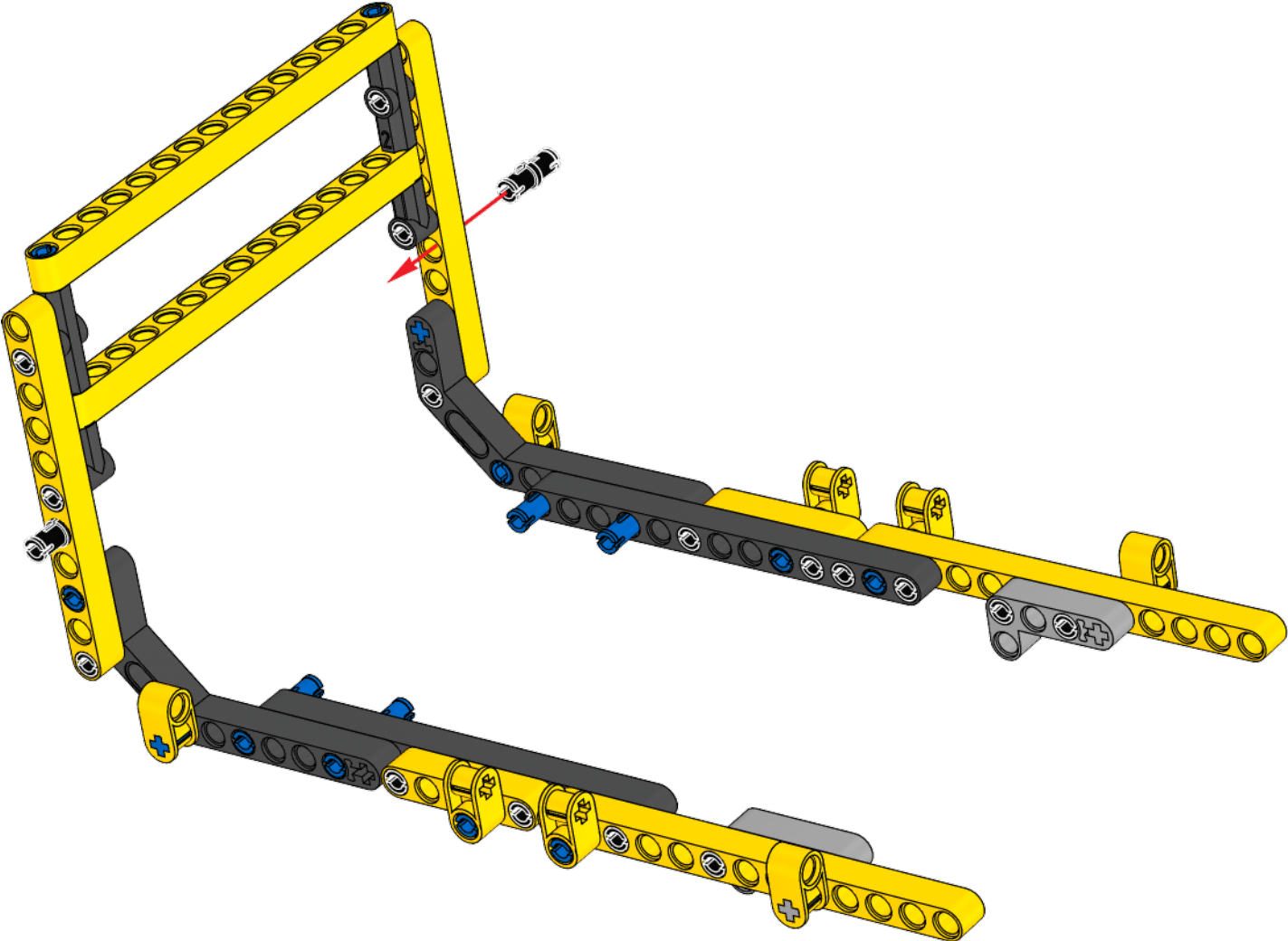

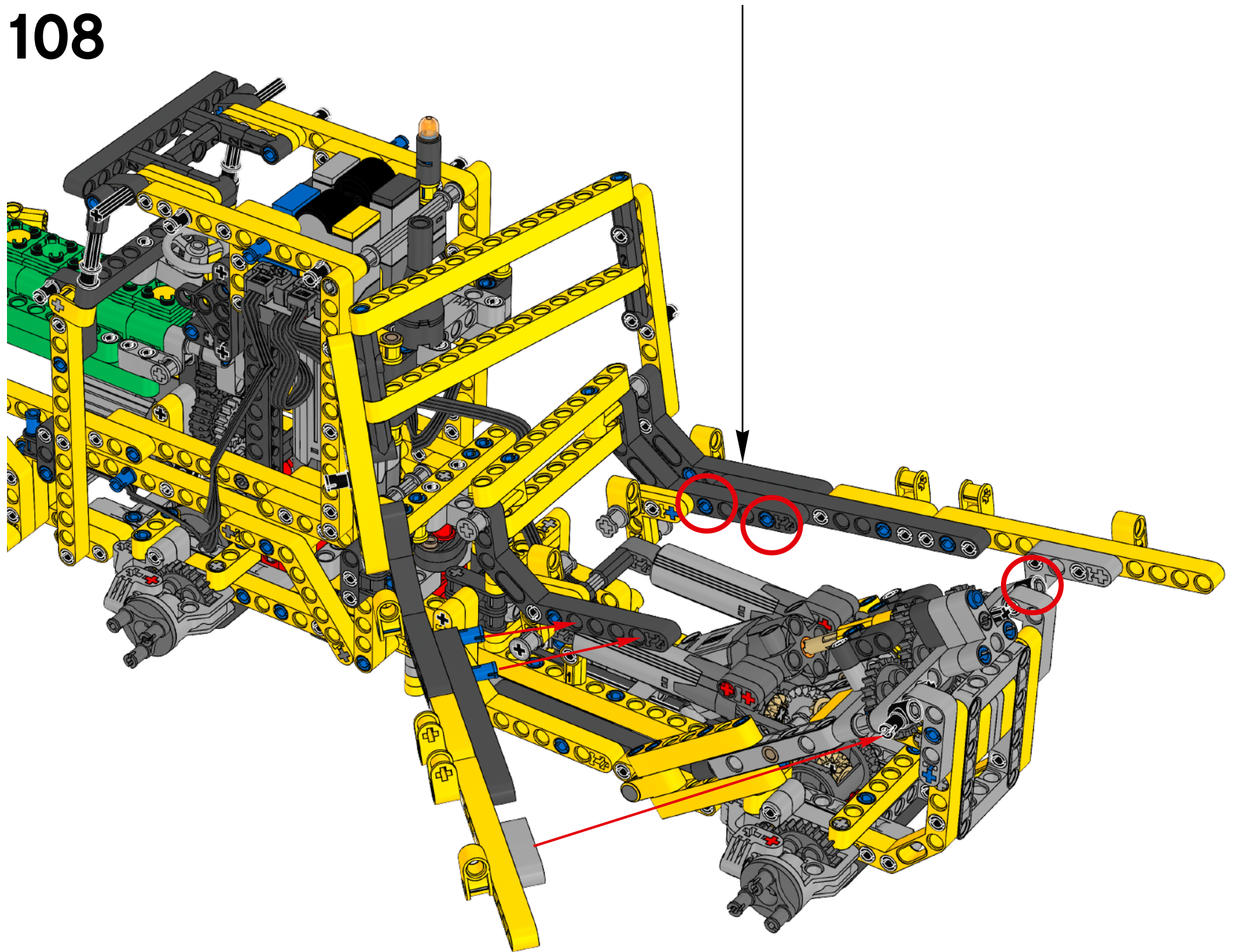

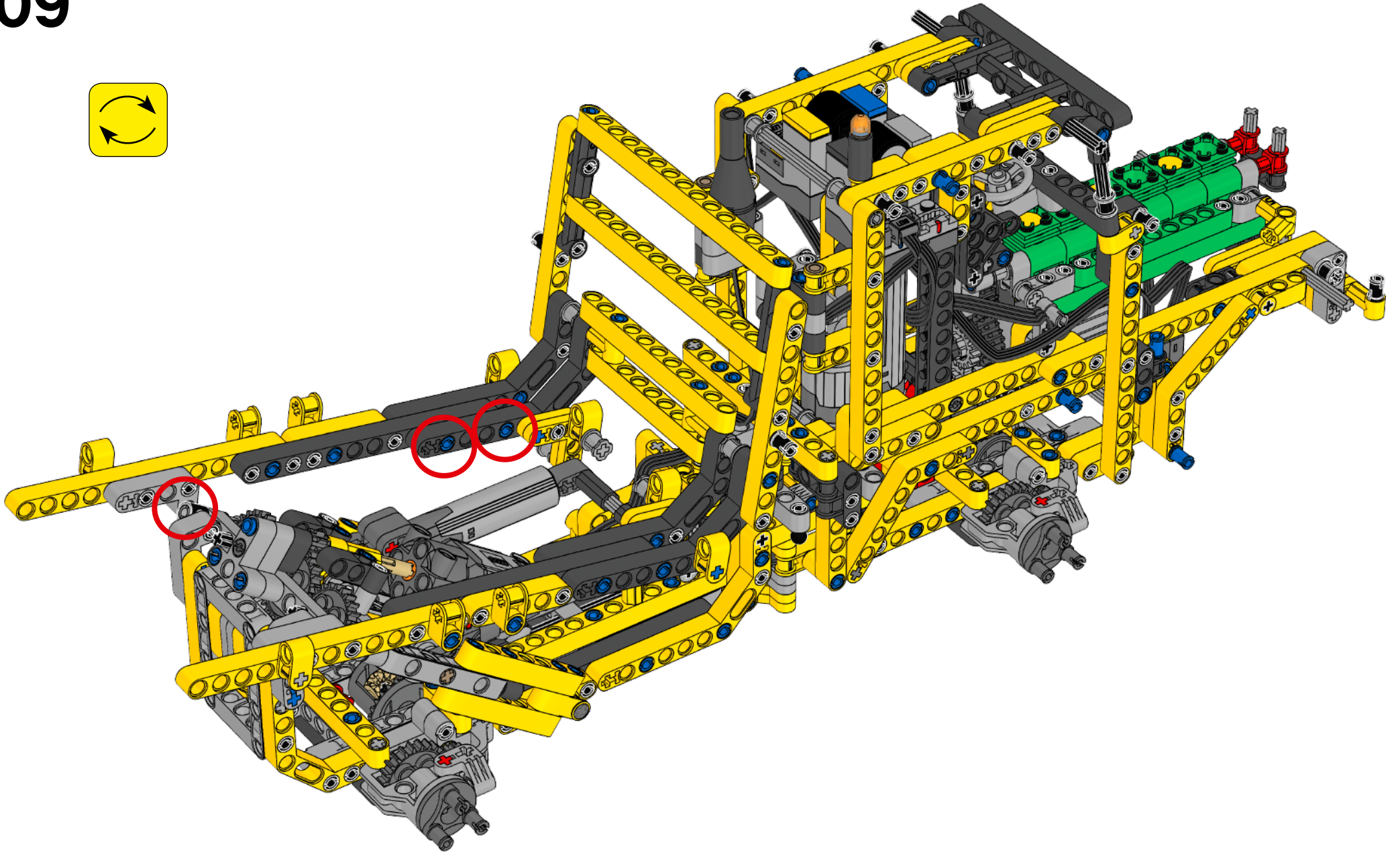
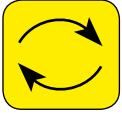

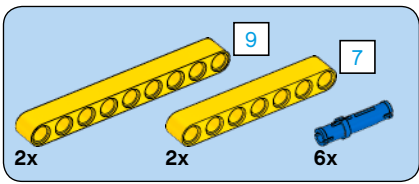

110

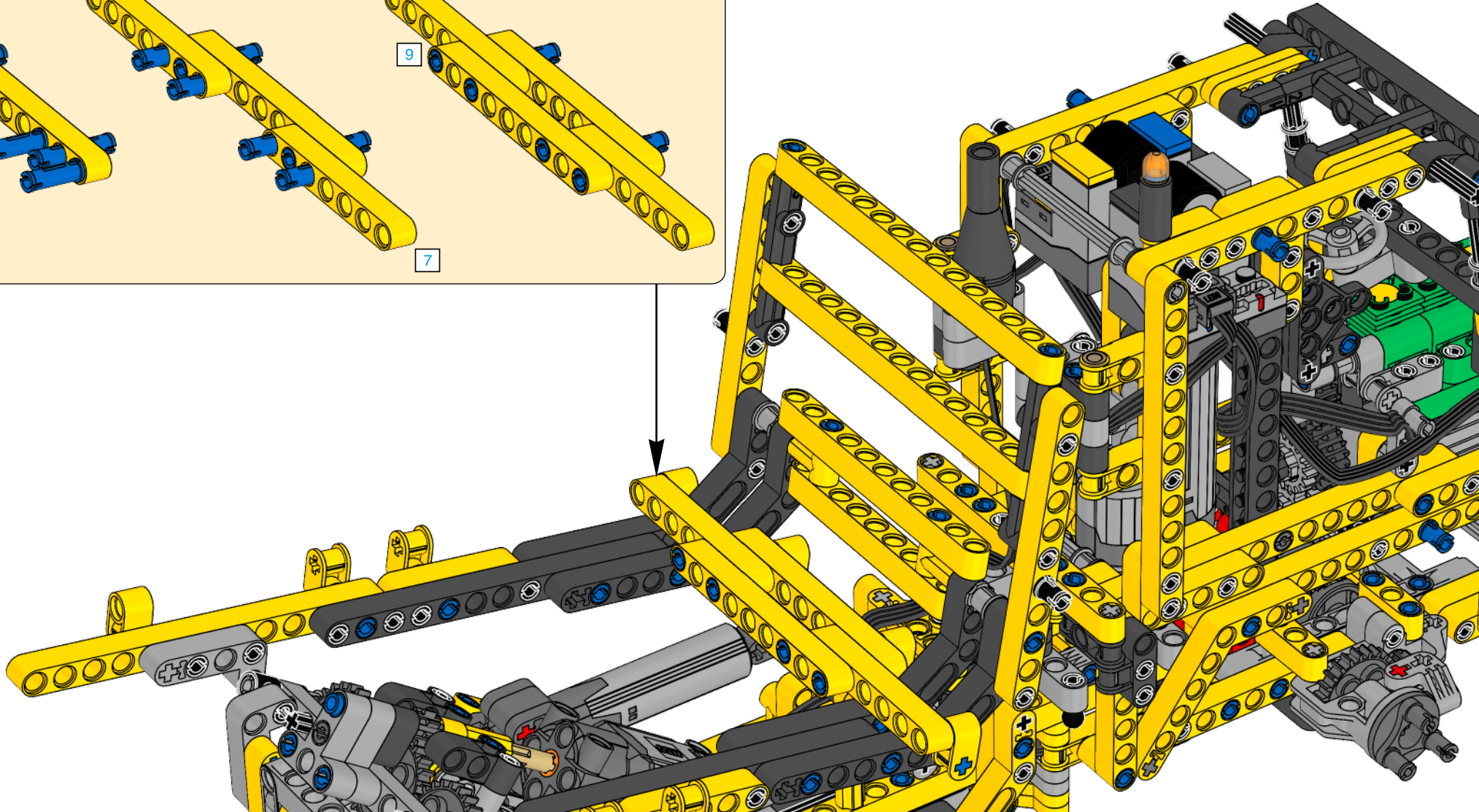
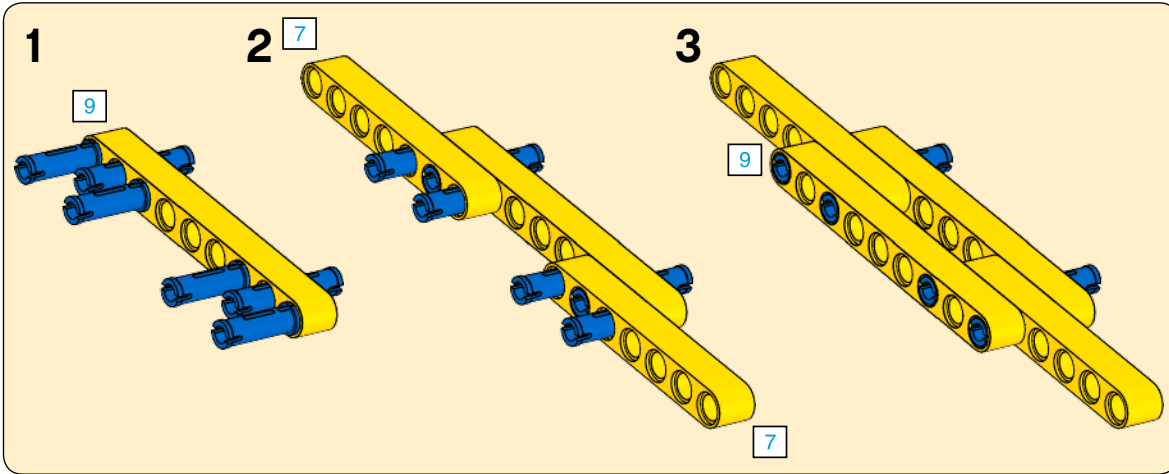

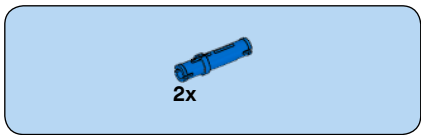

111

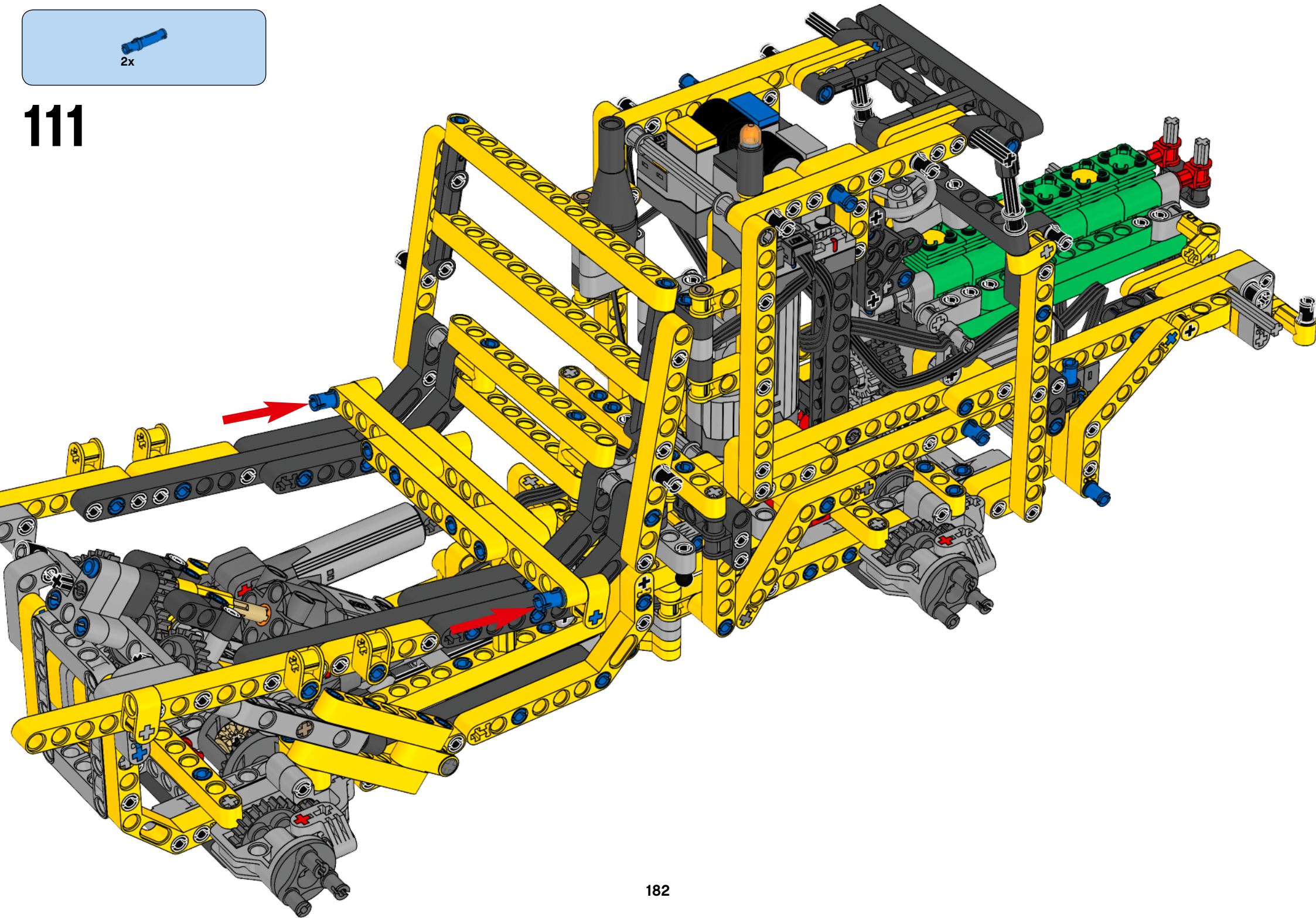

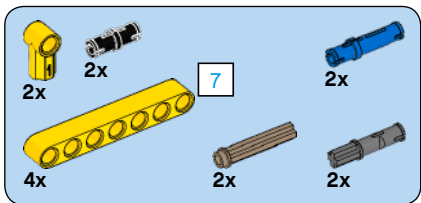

112

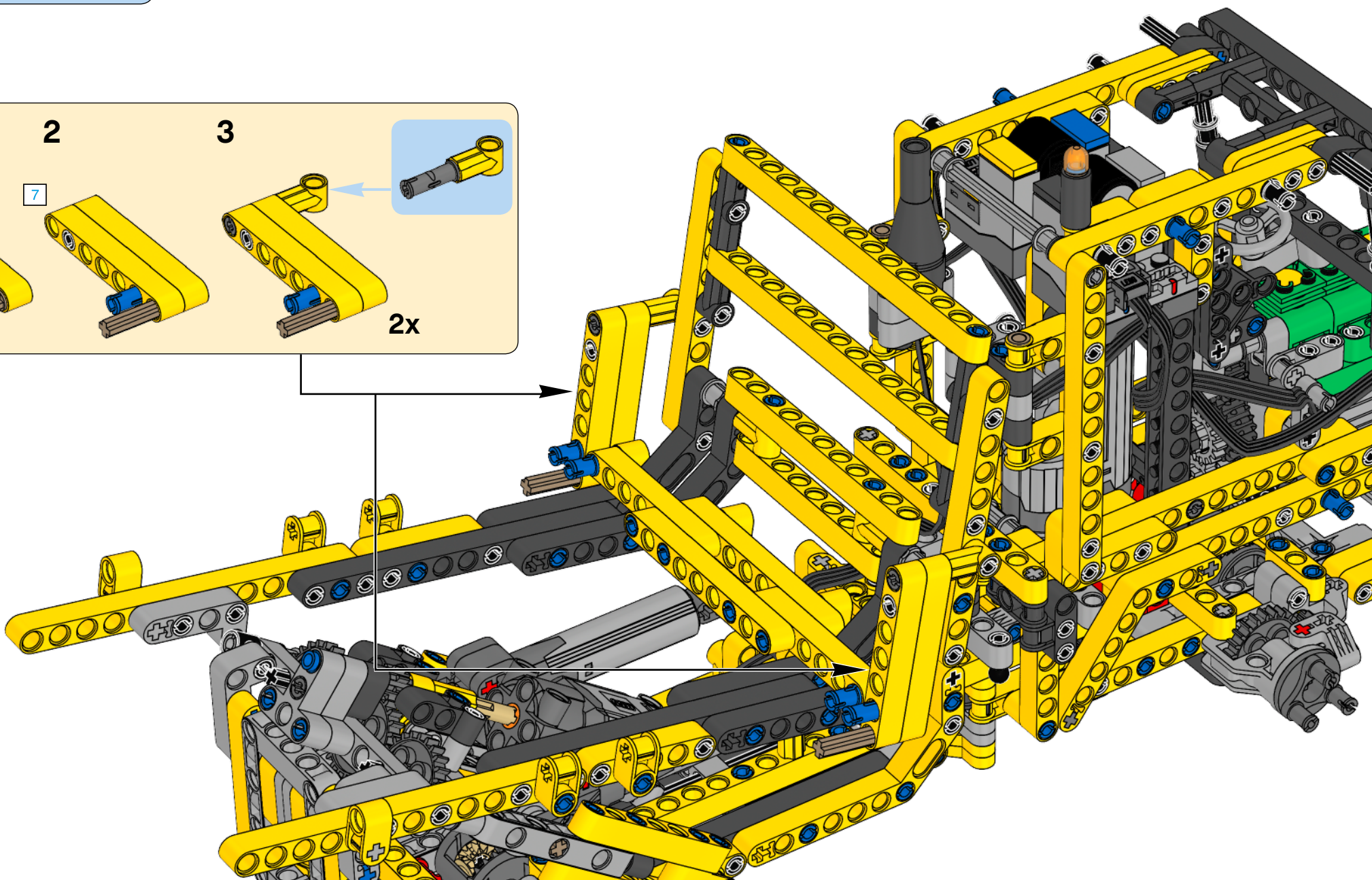
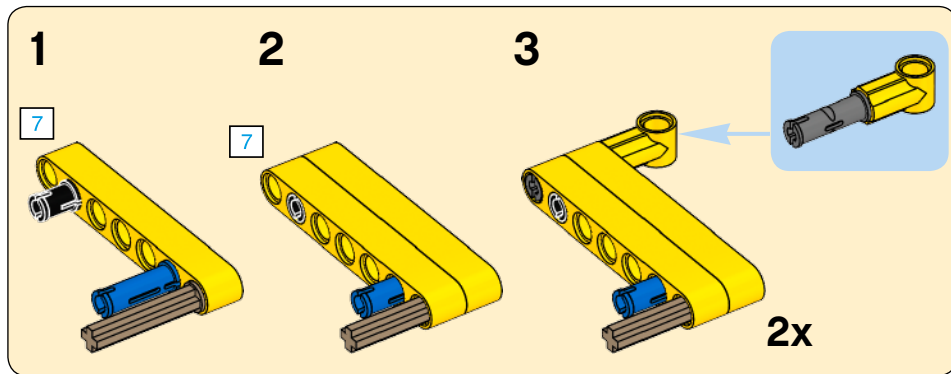

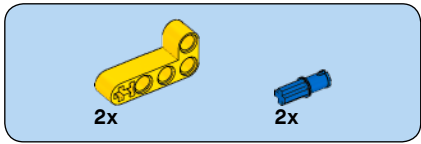

113

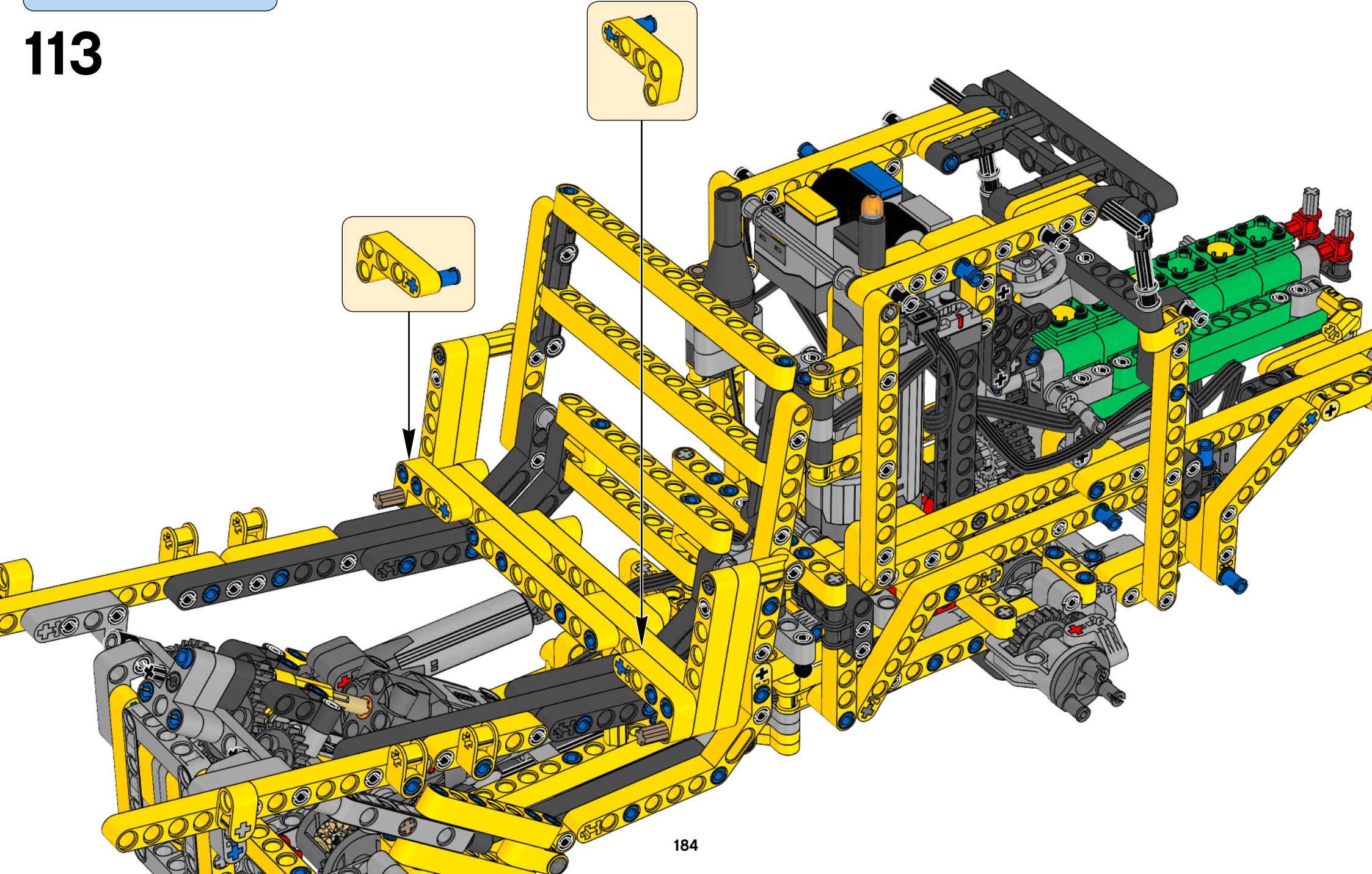

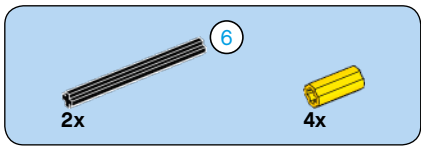

114

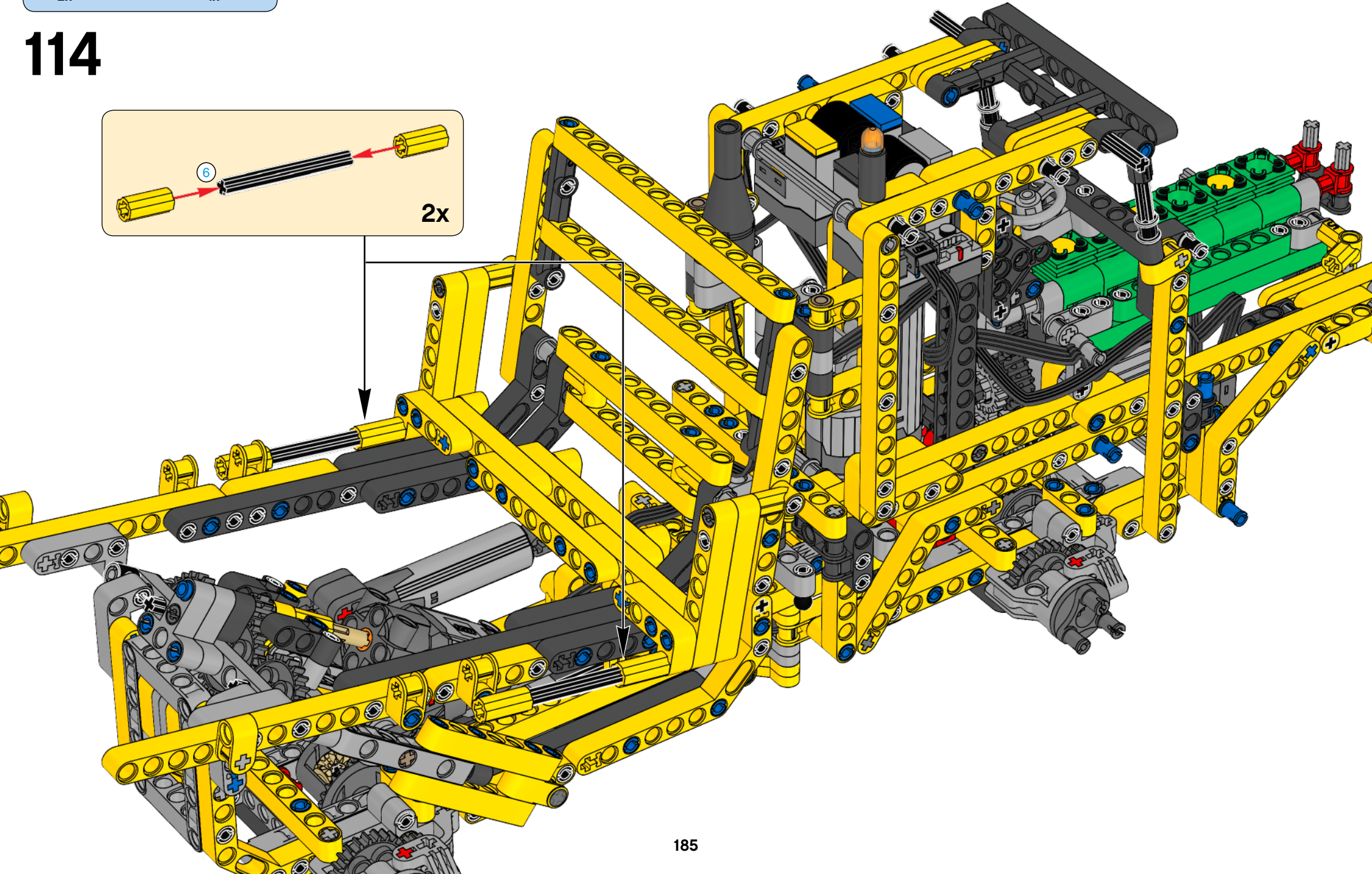
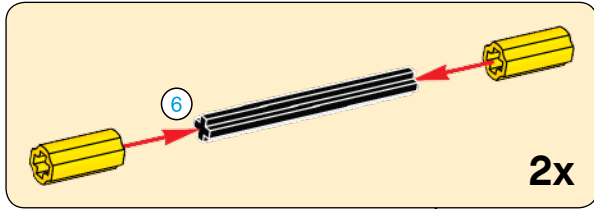

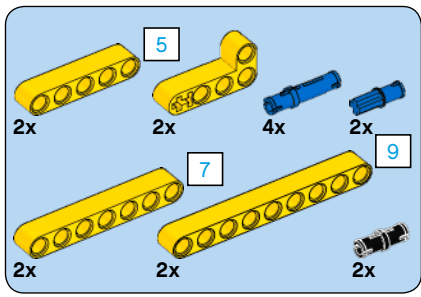

115

1

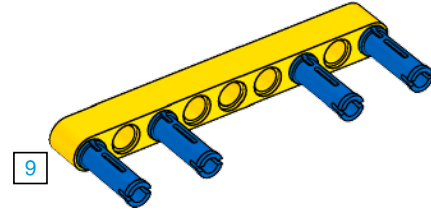

2

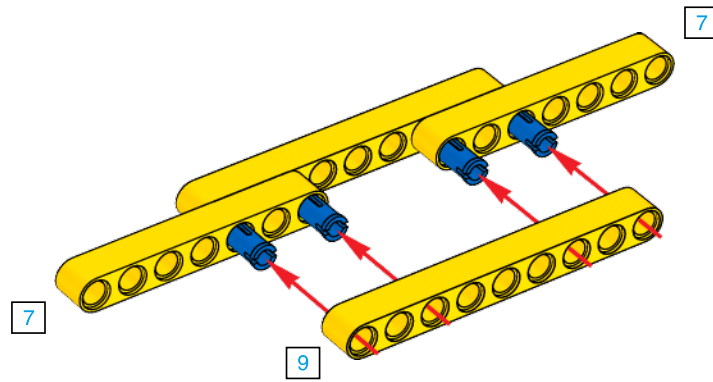

3

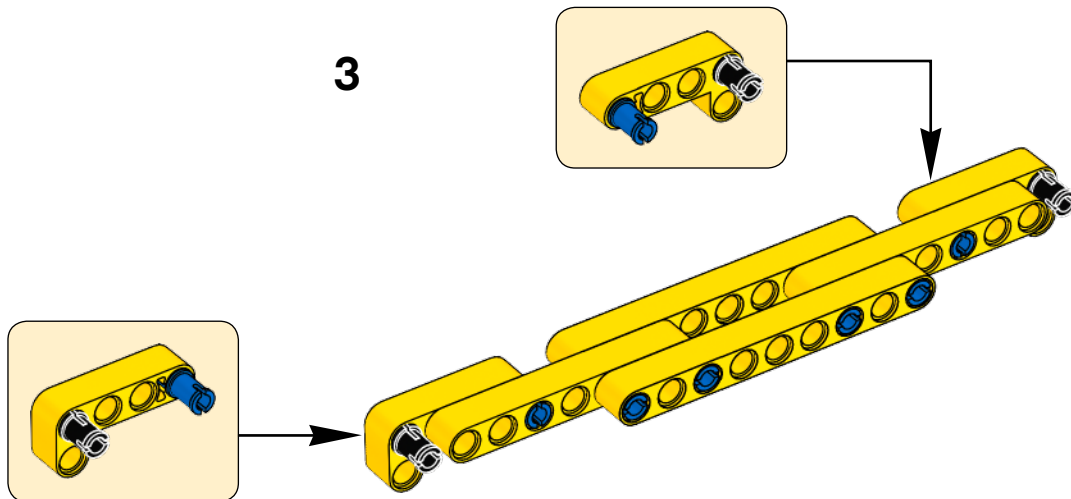

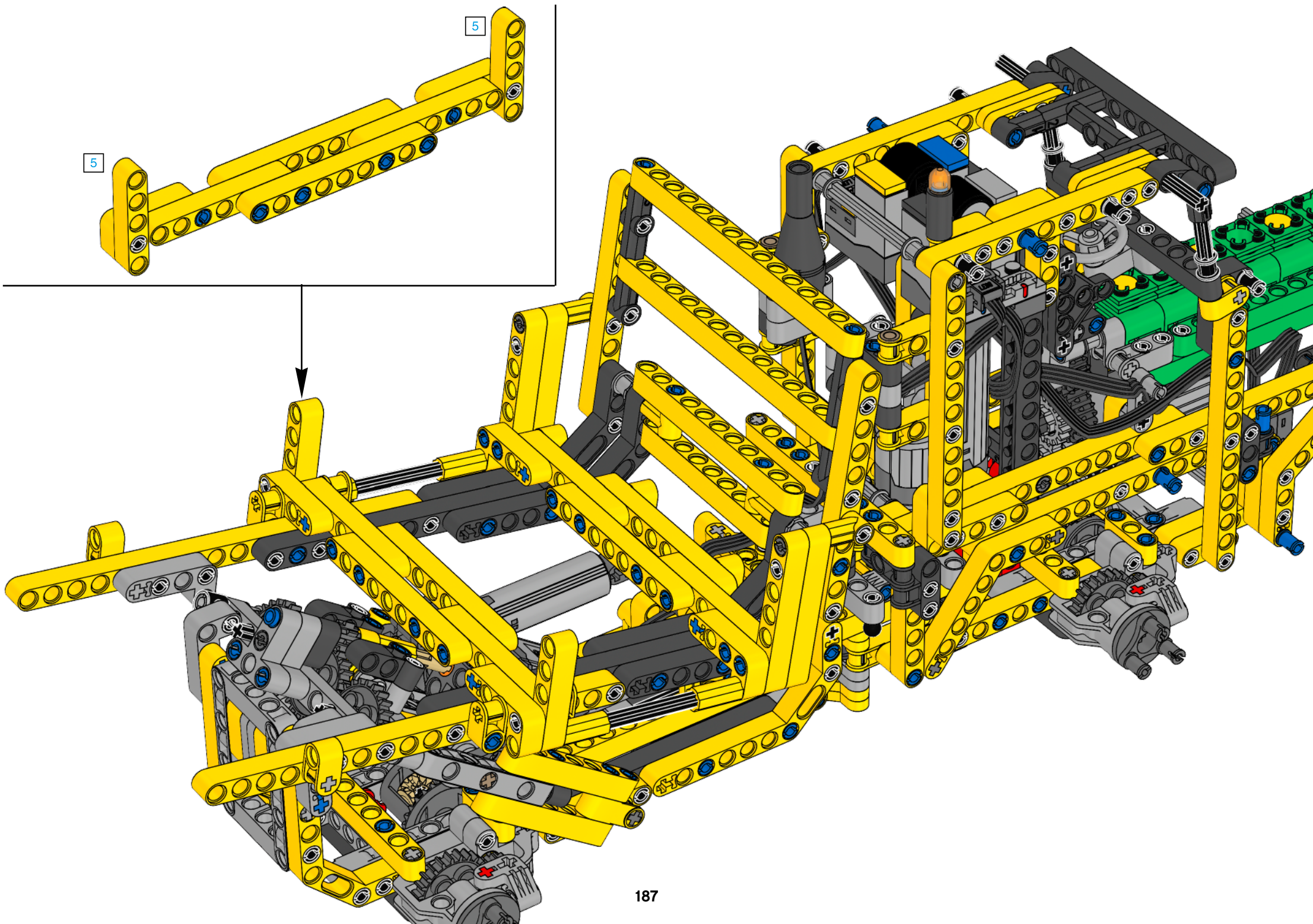

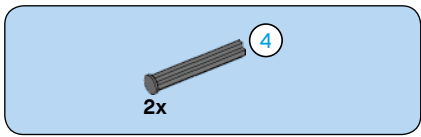

116

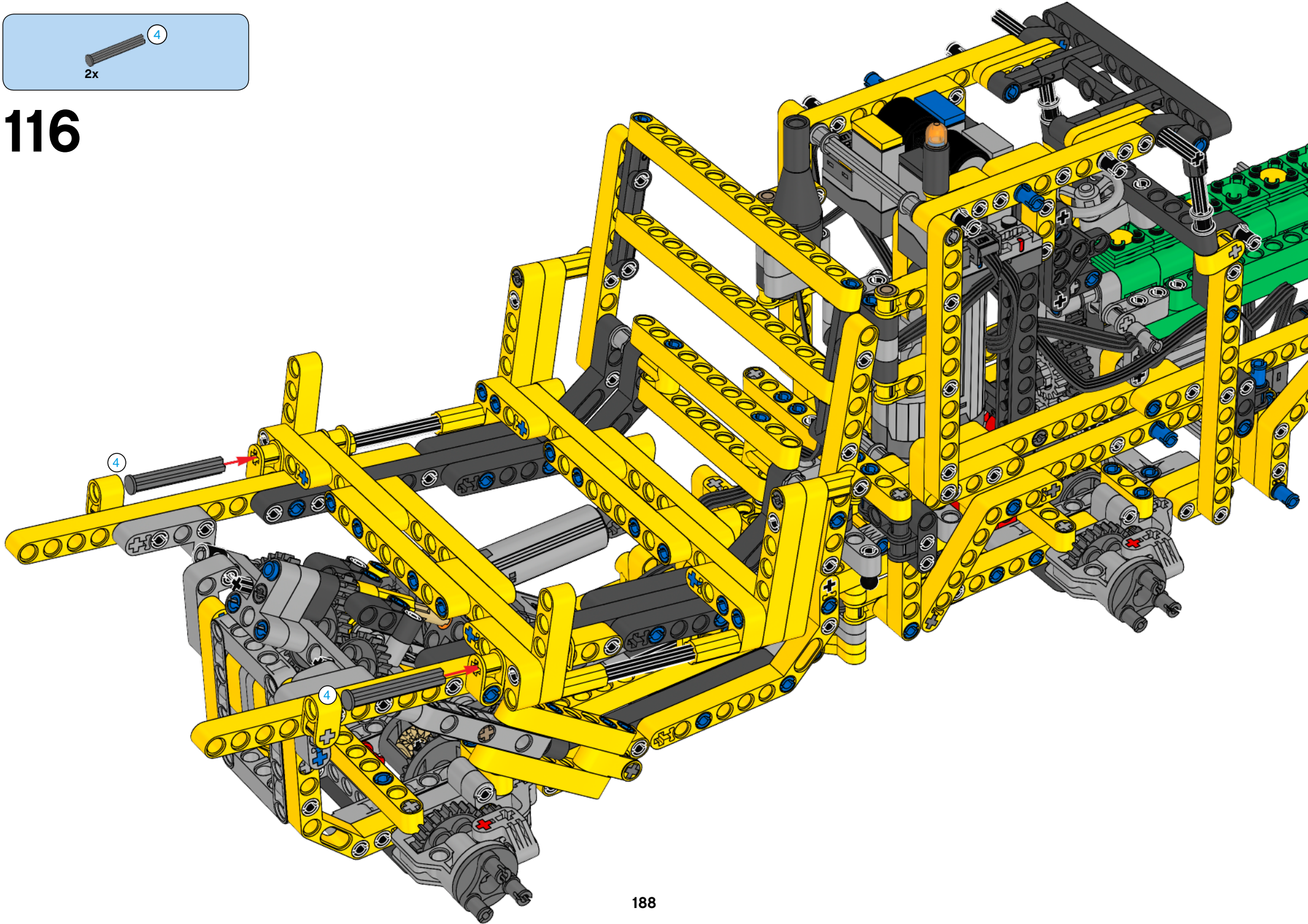

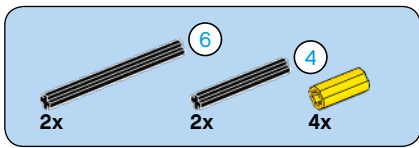

117

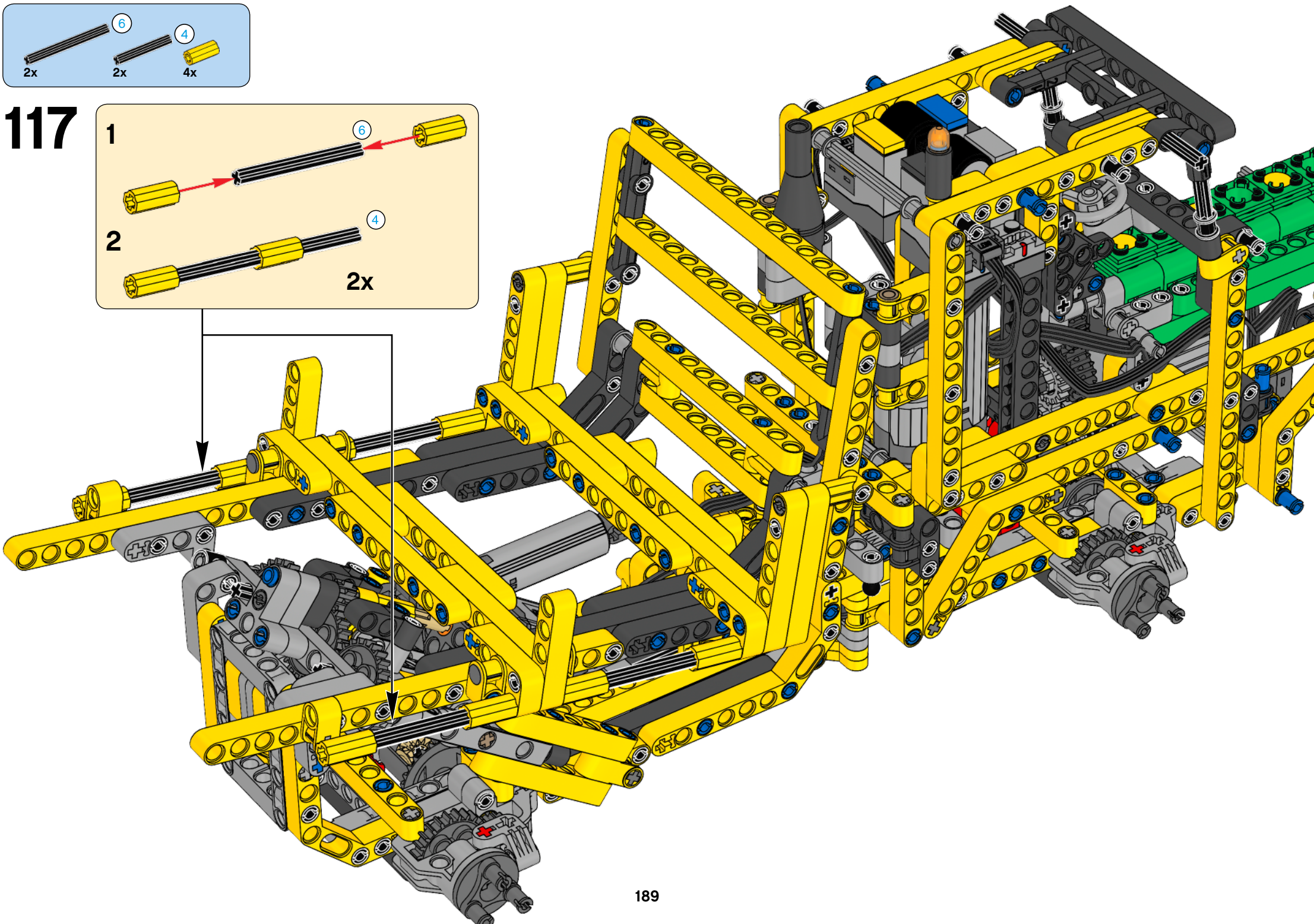
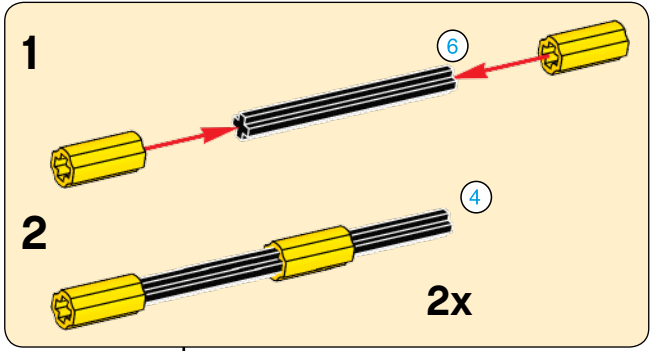

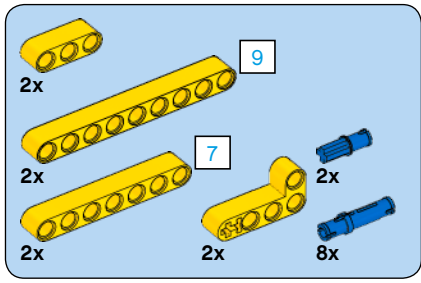

118

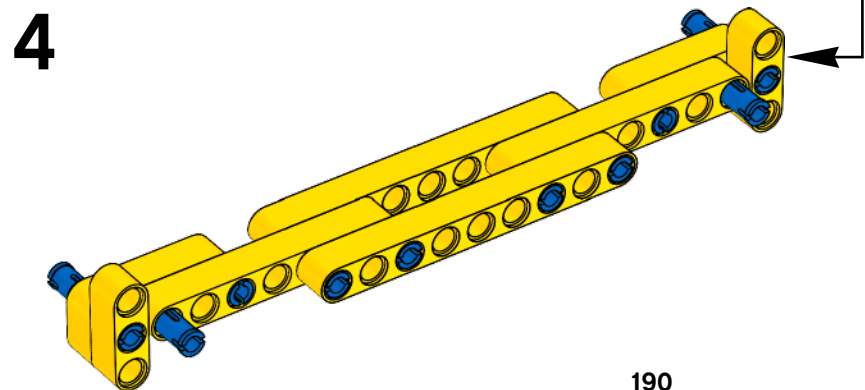
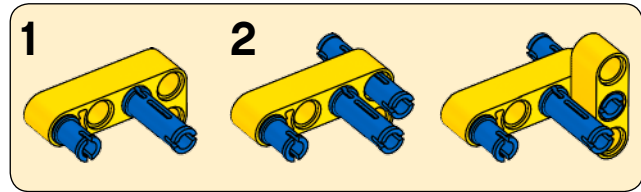
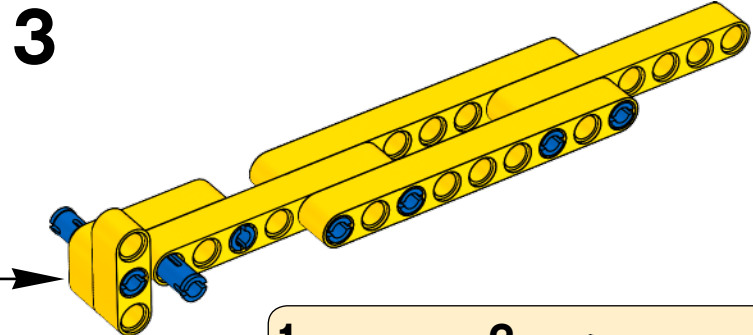
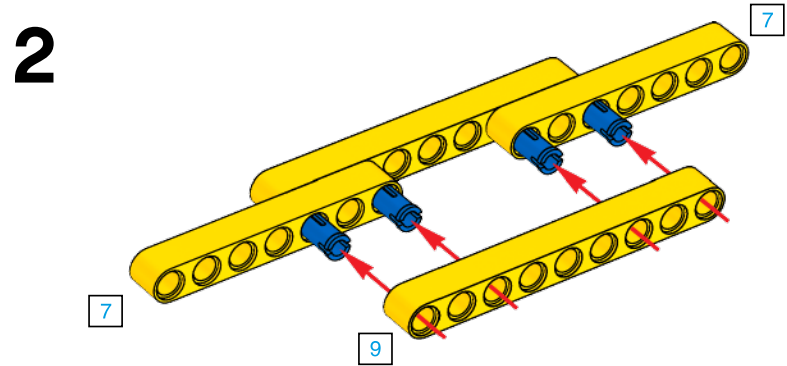
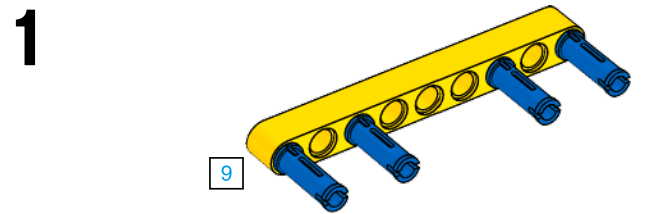
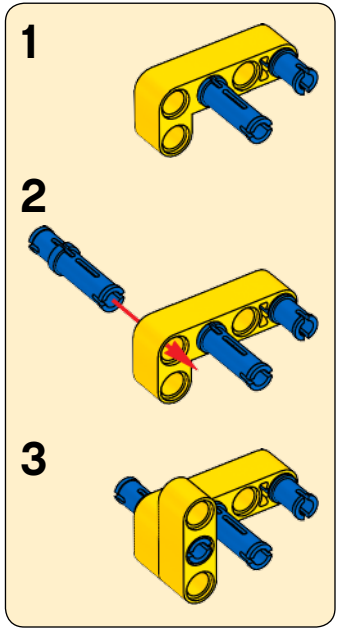

5

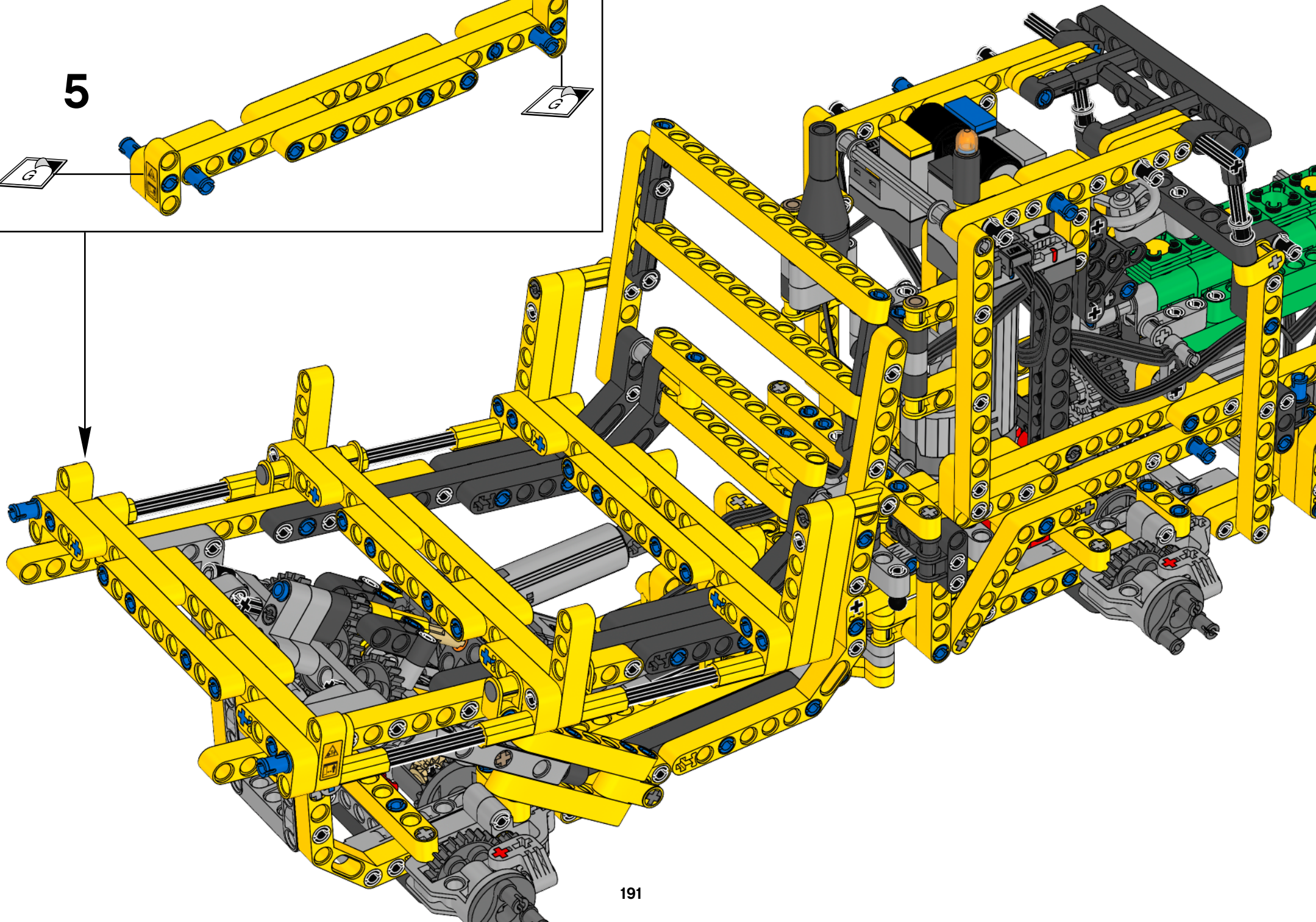
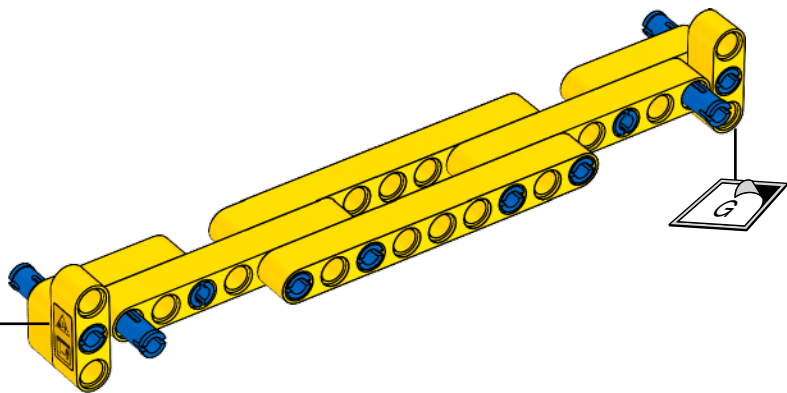

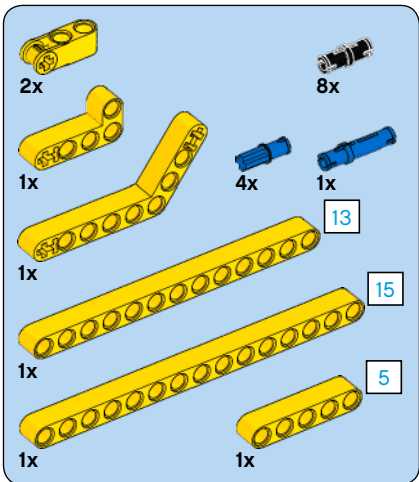
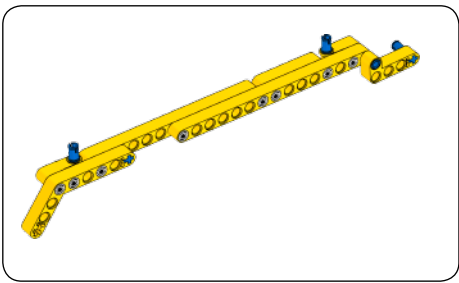

119

1

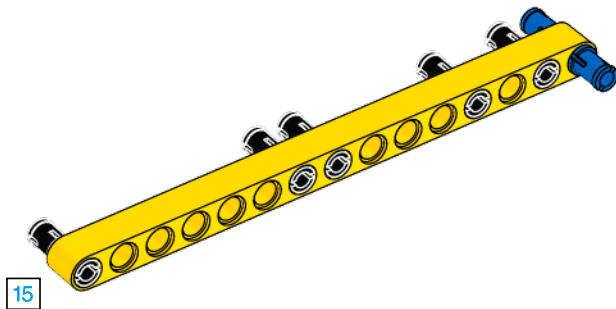

2

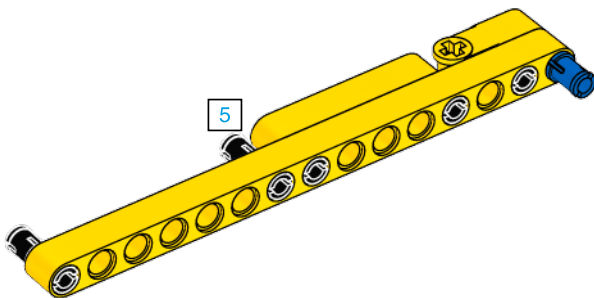

3

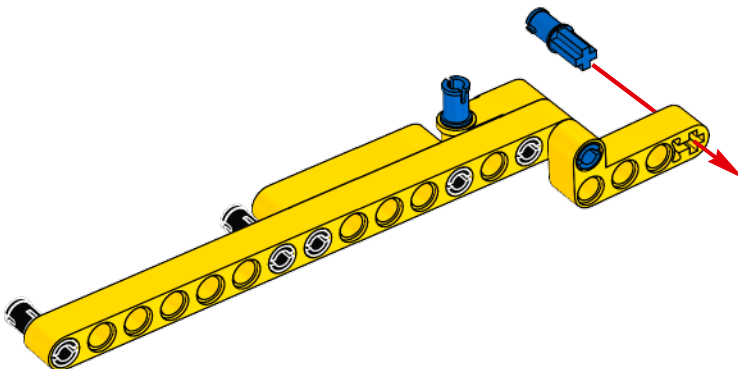

4

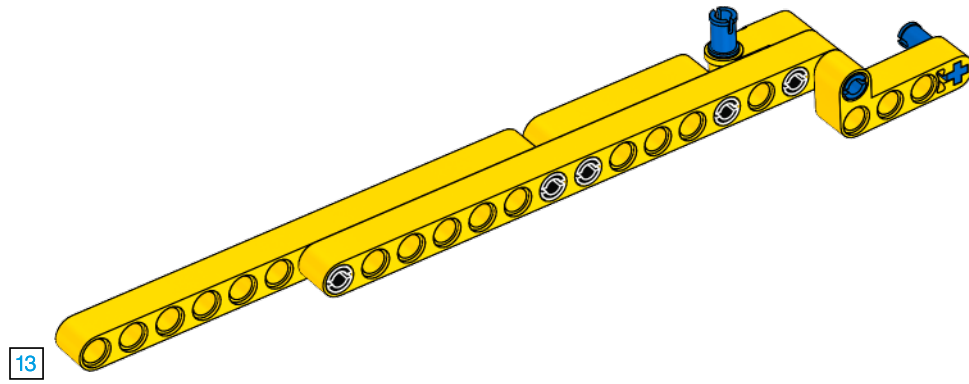

5

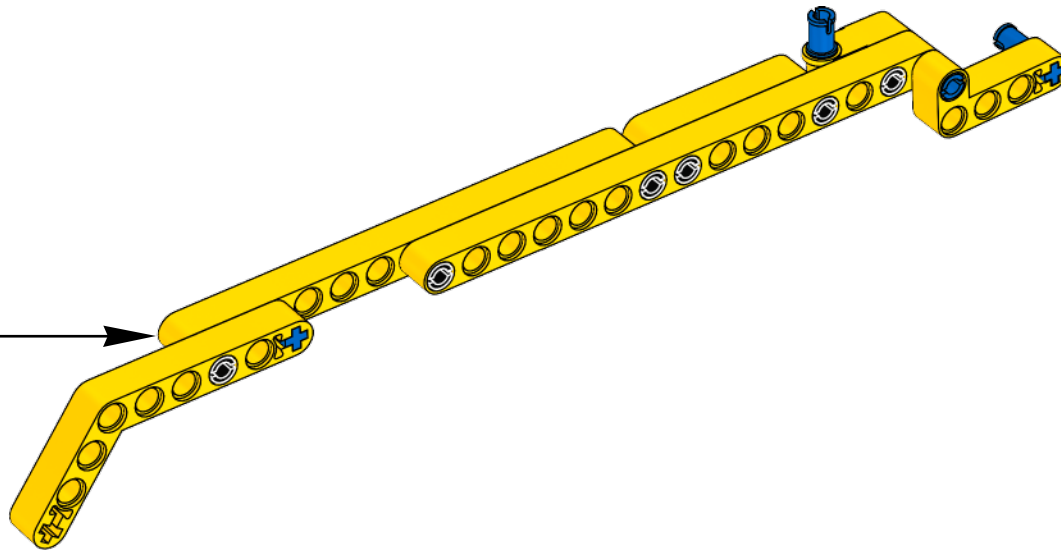
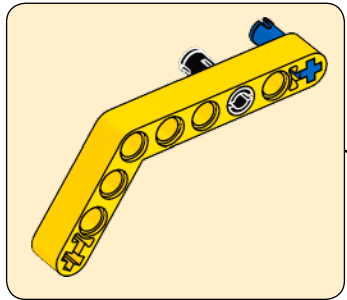

6

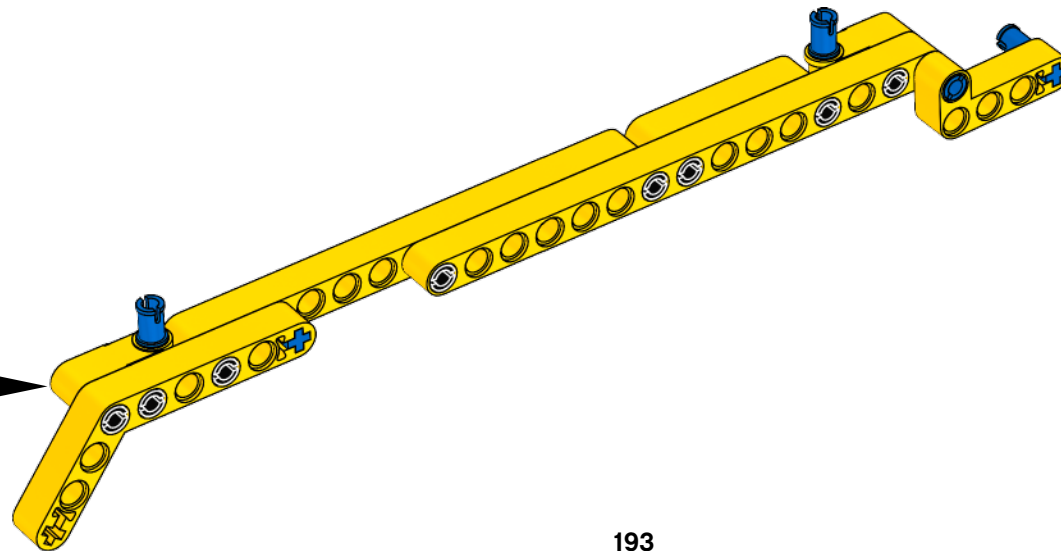
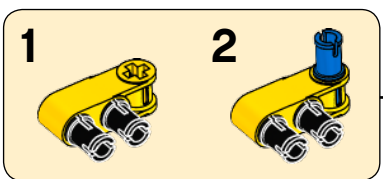

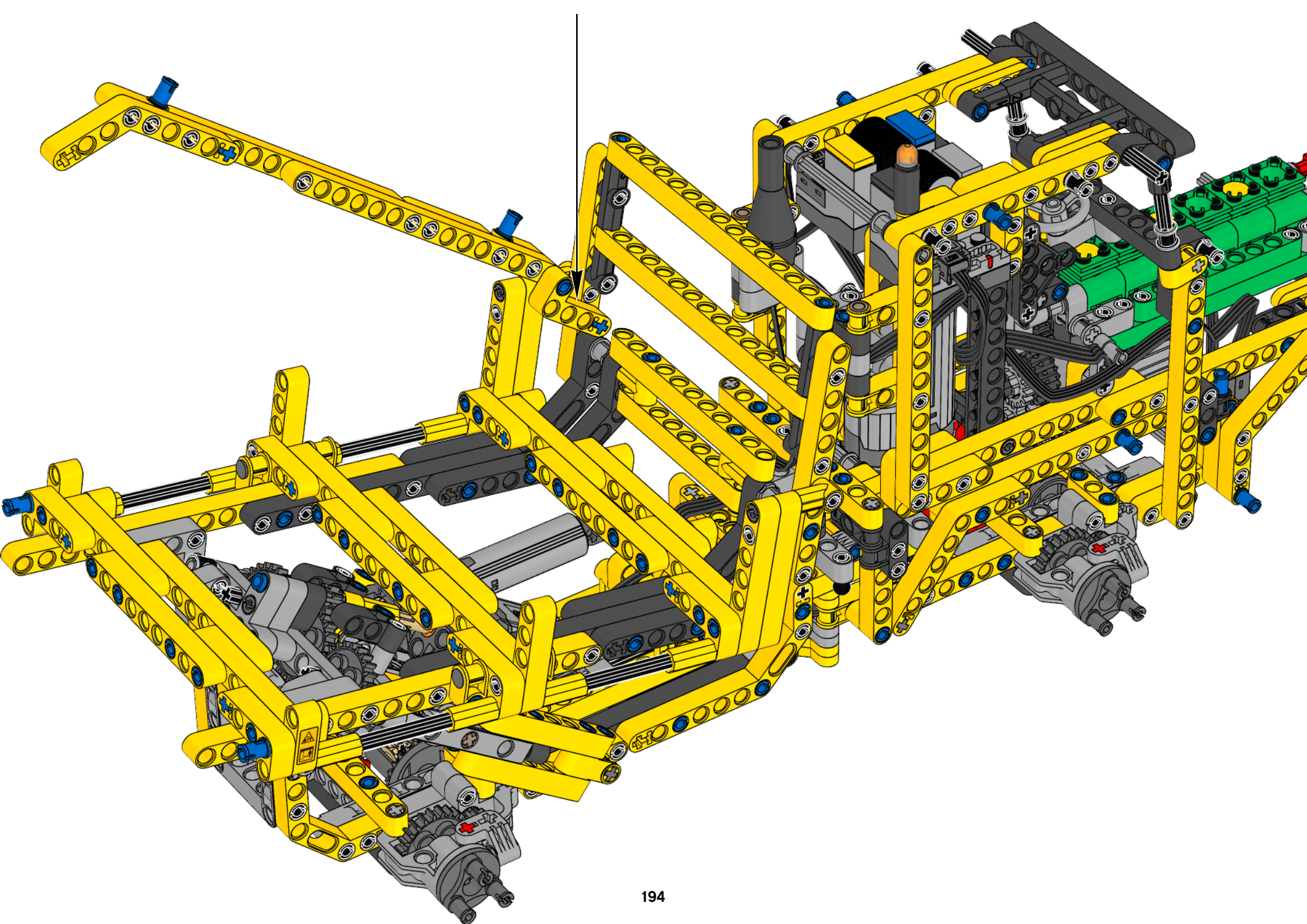

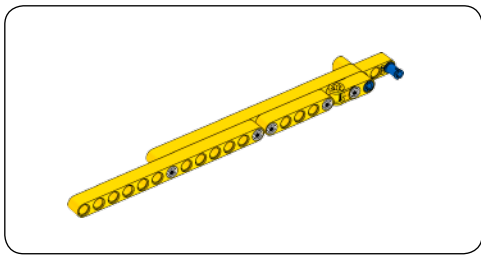

1

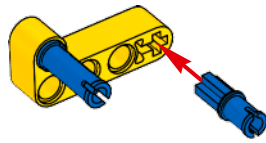

2

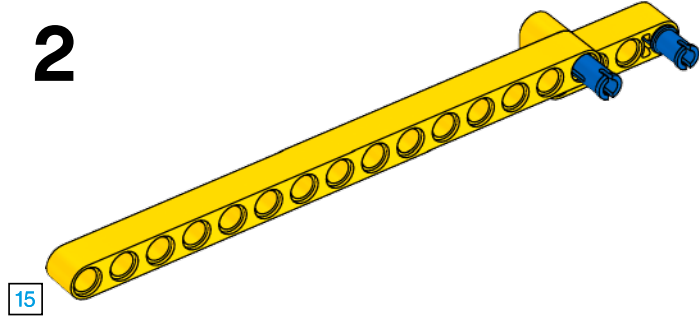

3

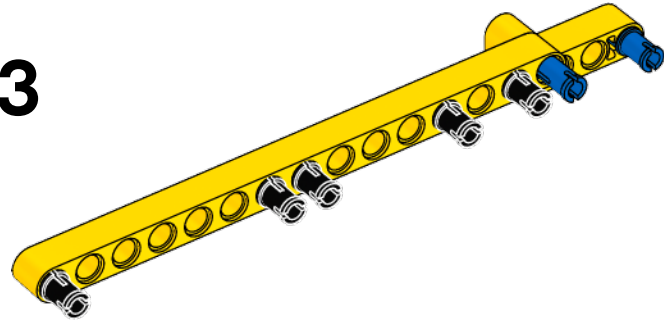

4

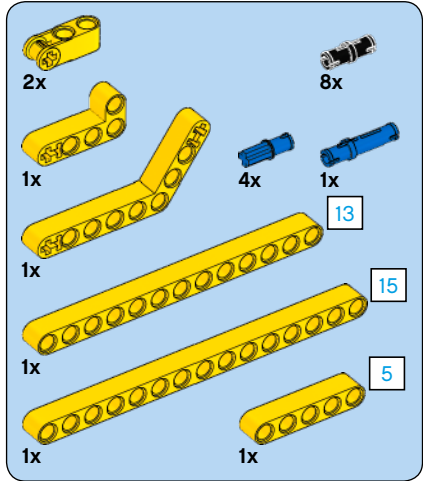
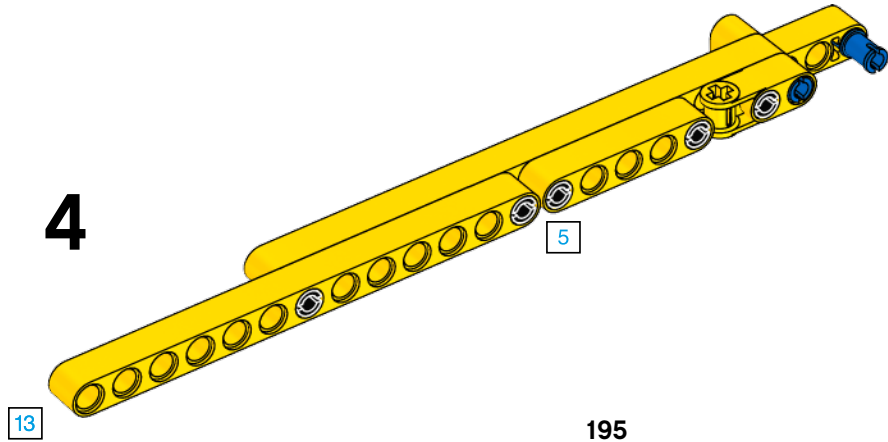

120

5

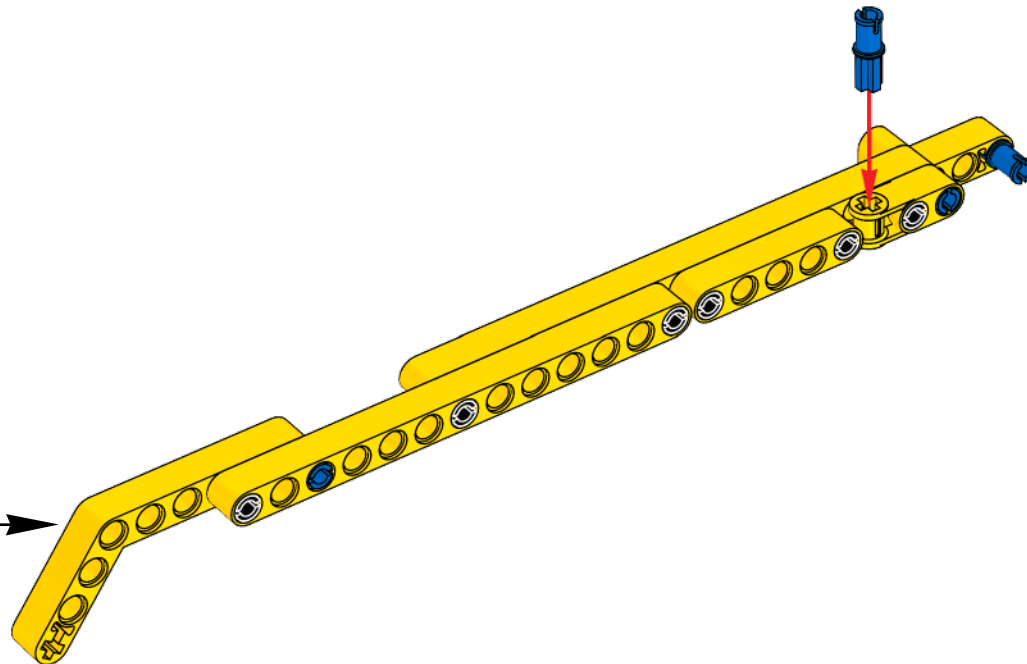
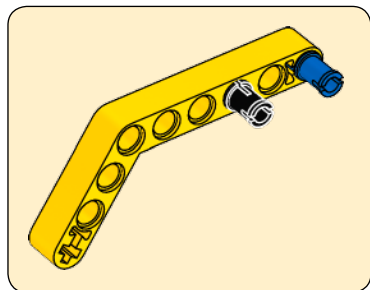

6

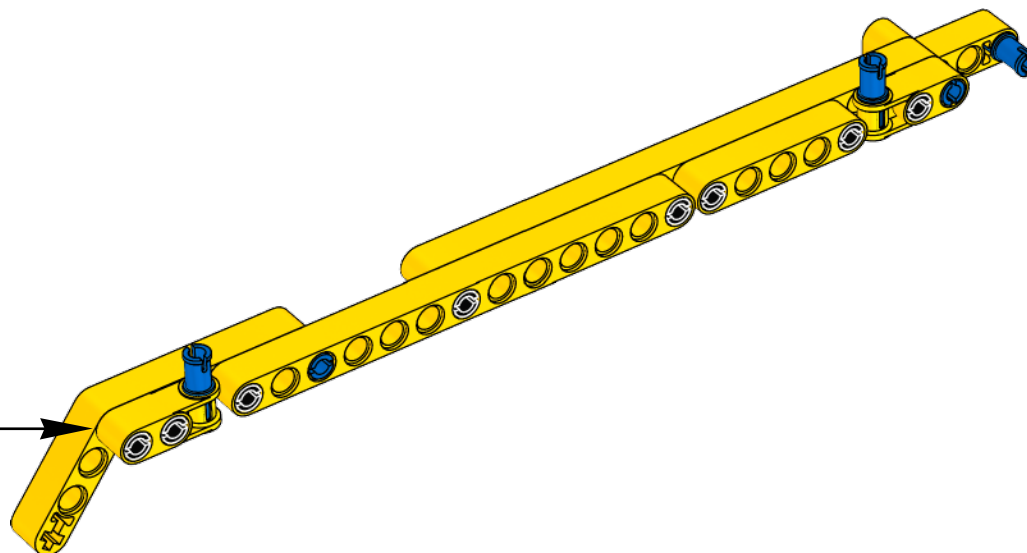
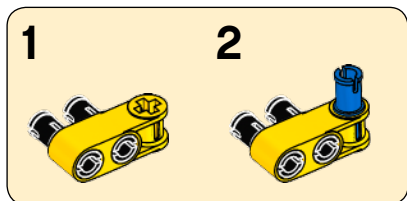

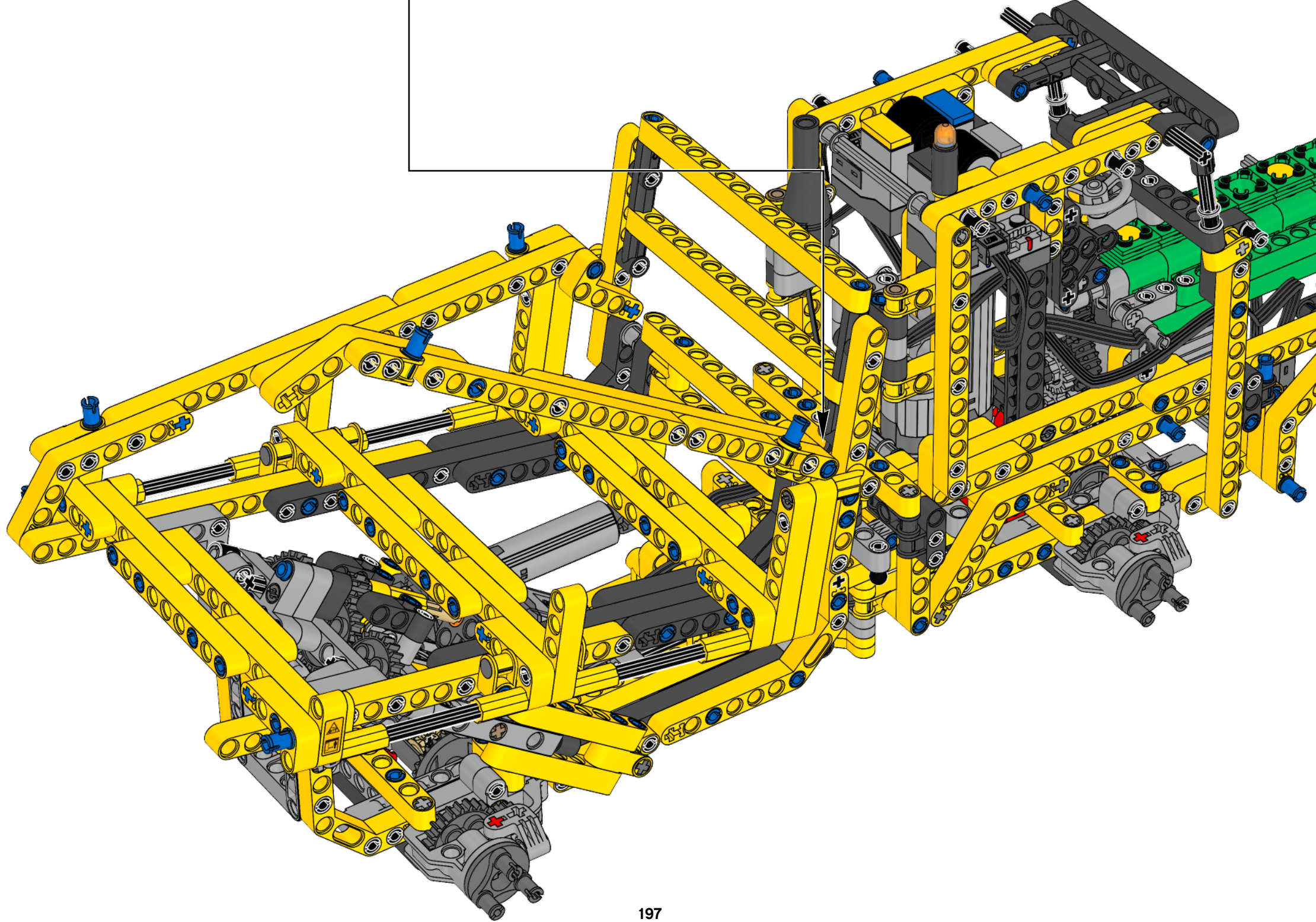

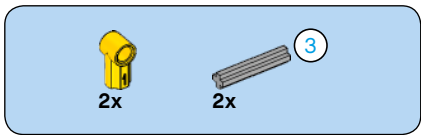

121

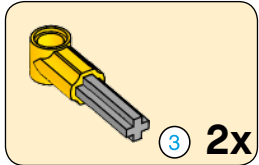
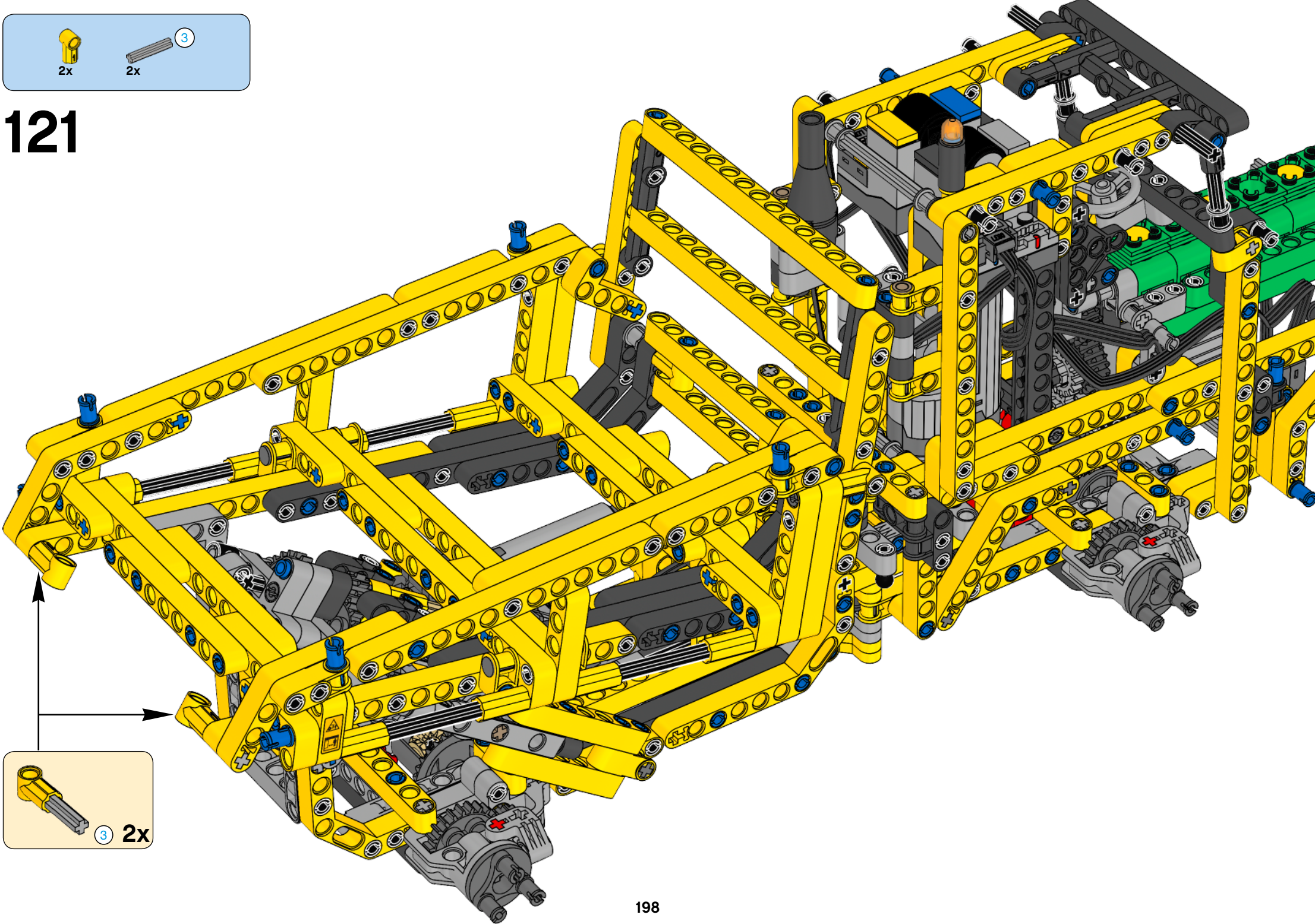

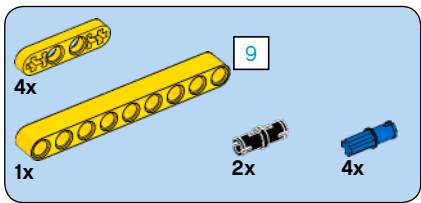

122

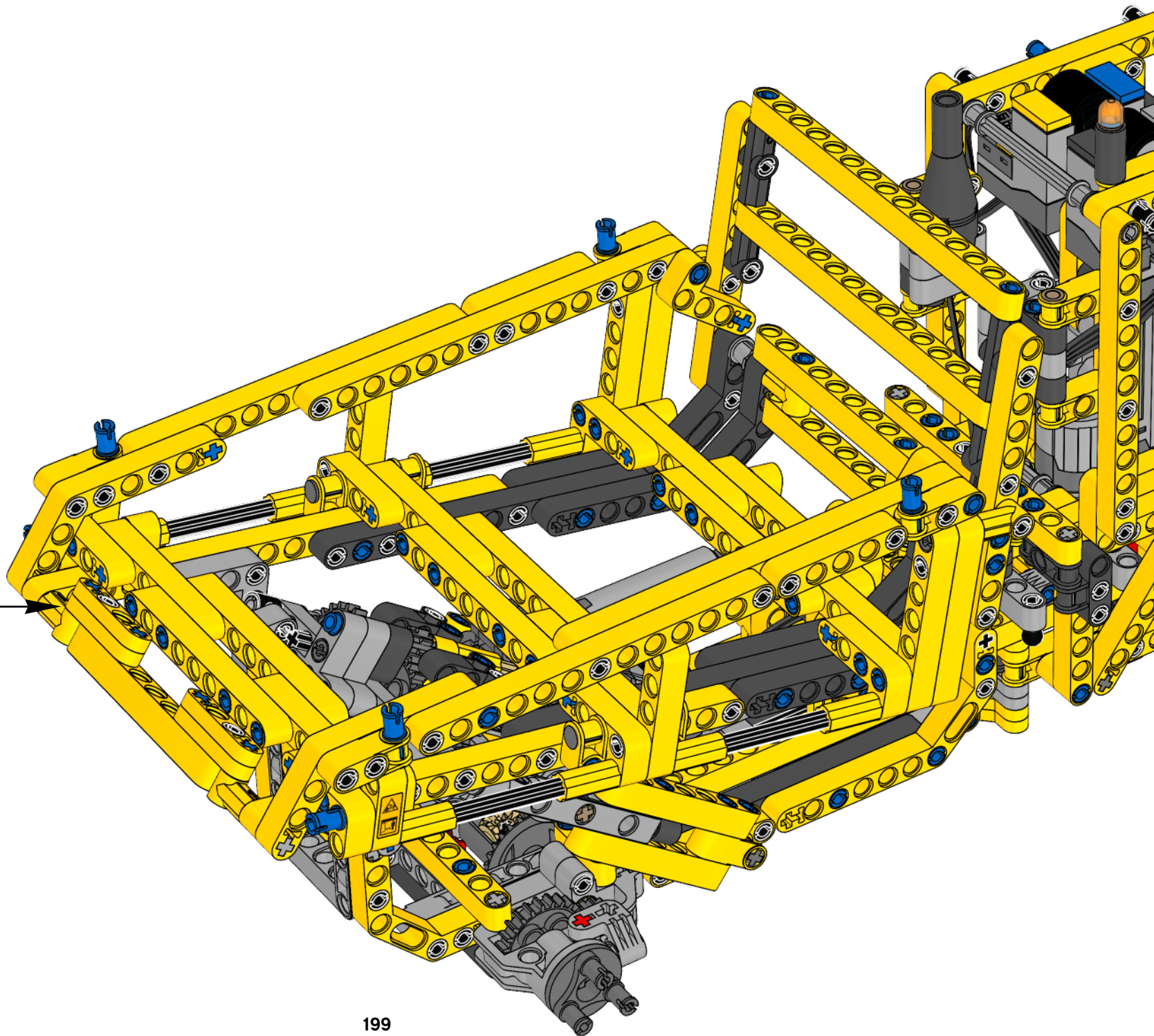
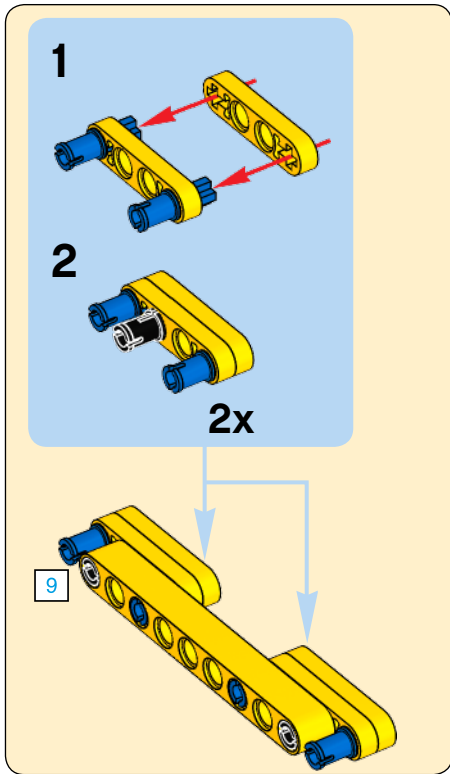

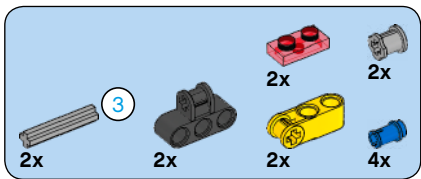

123

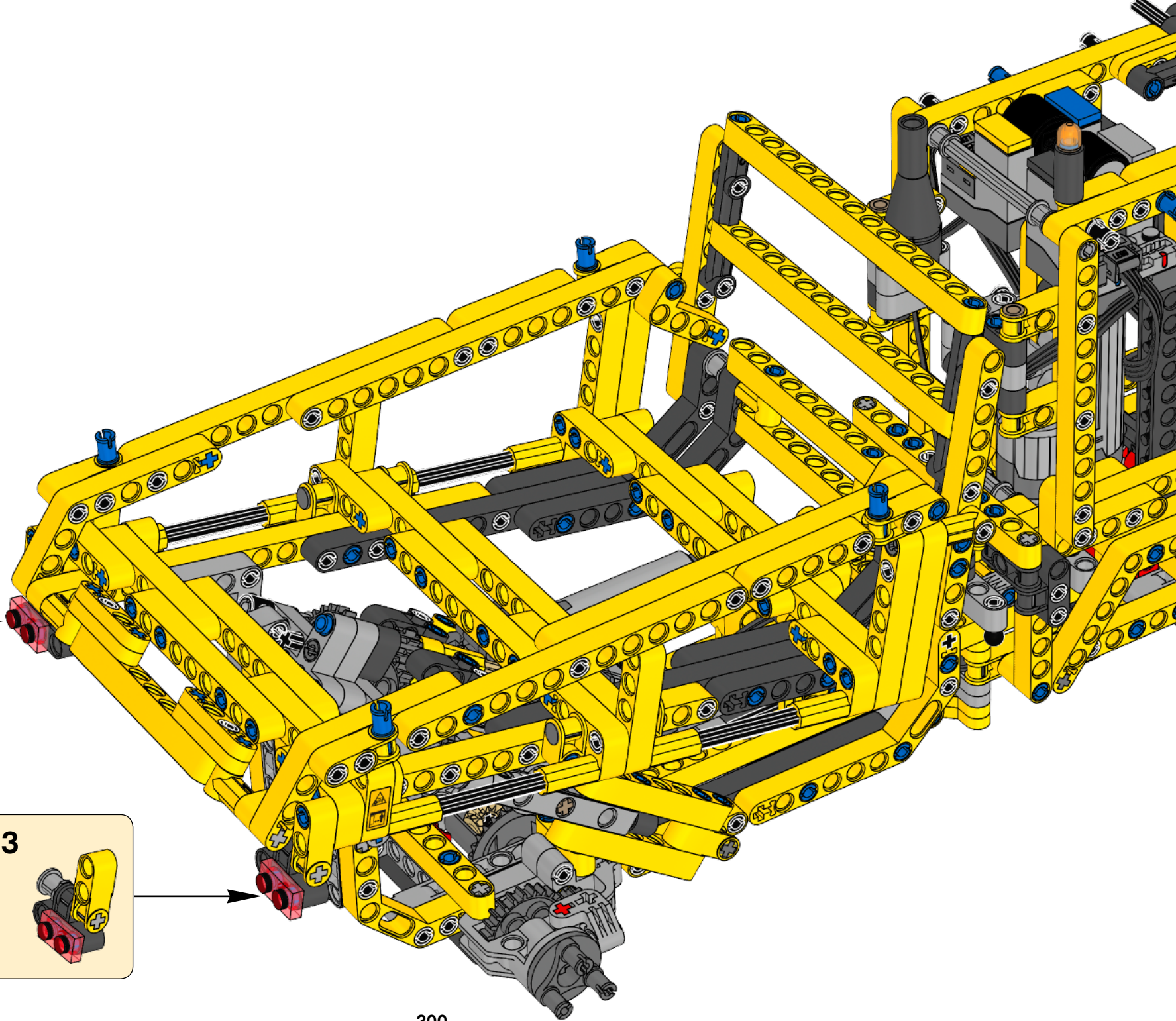
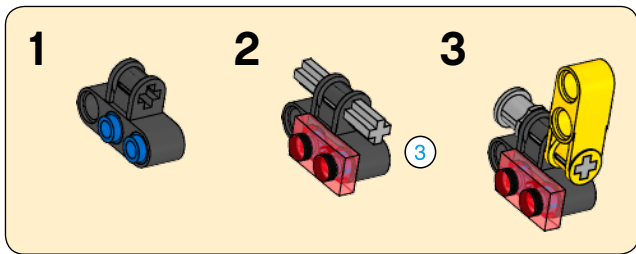
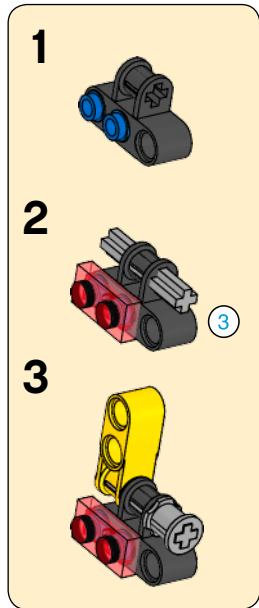

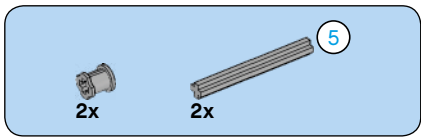

124

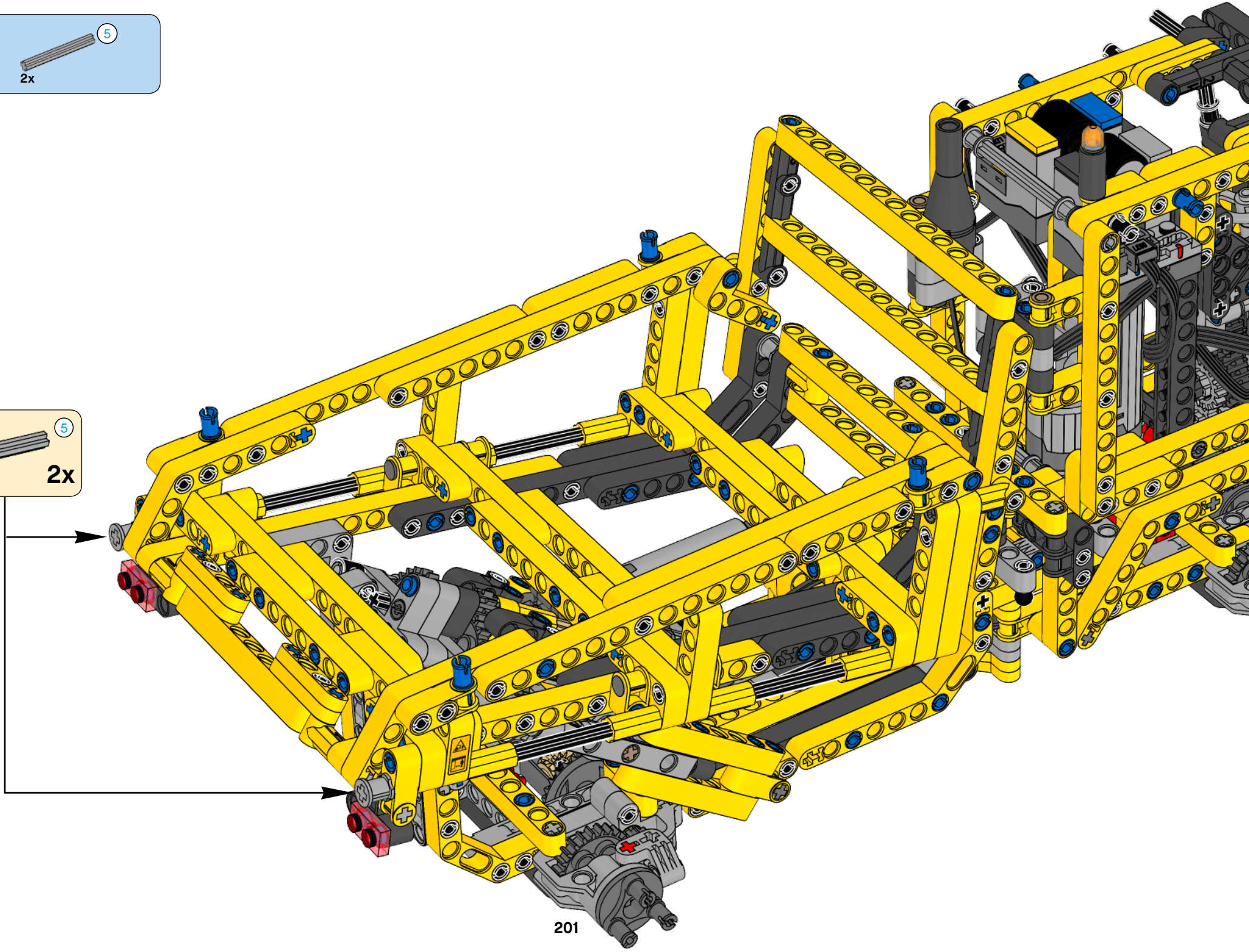
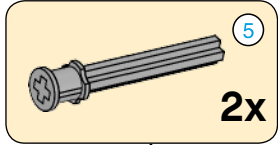

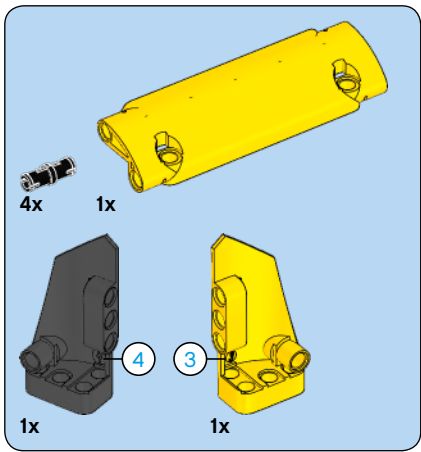

1

2

3

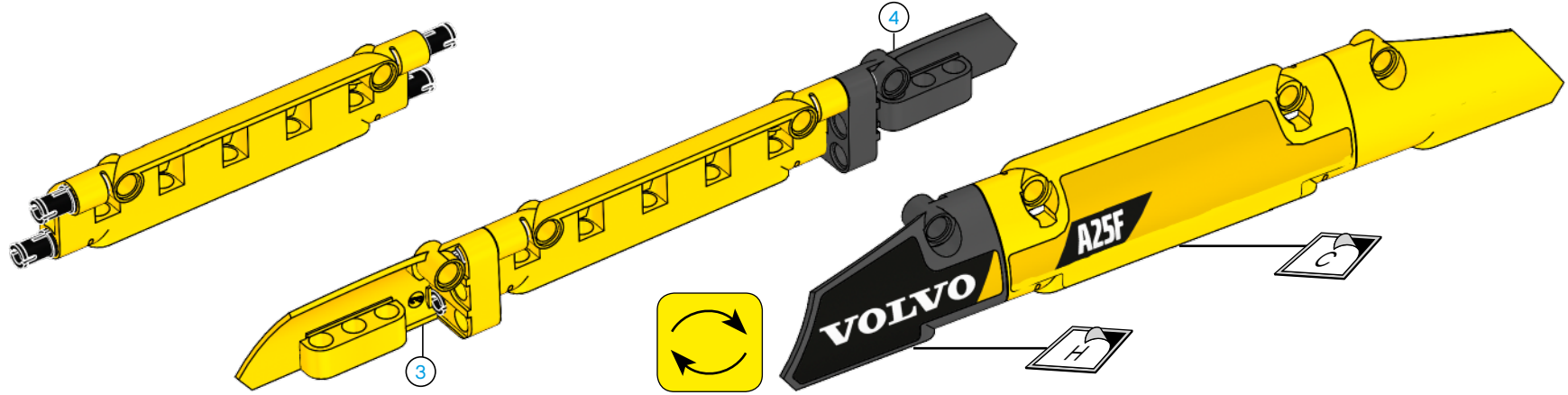

125

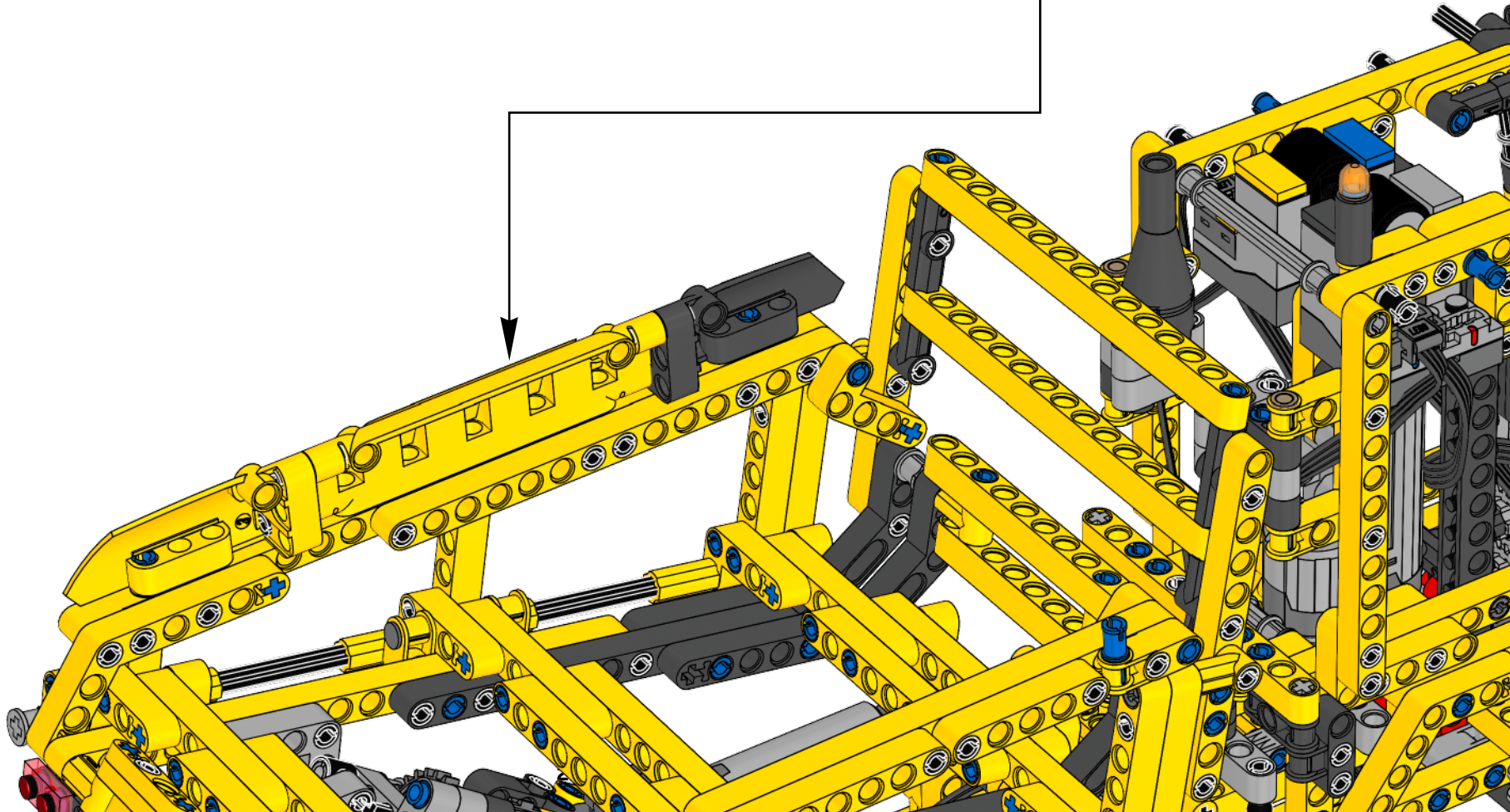

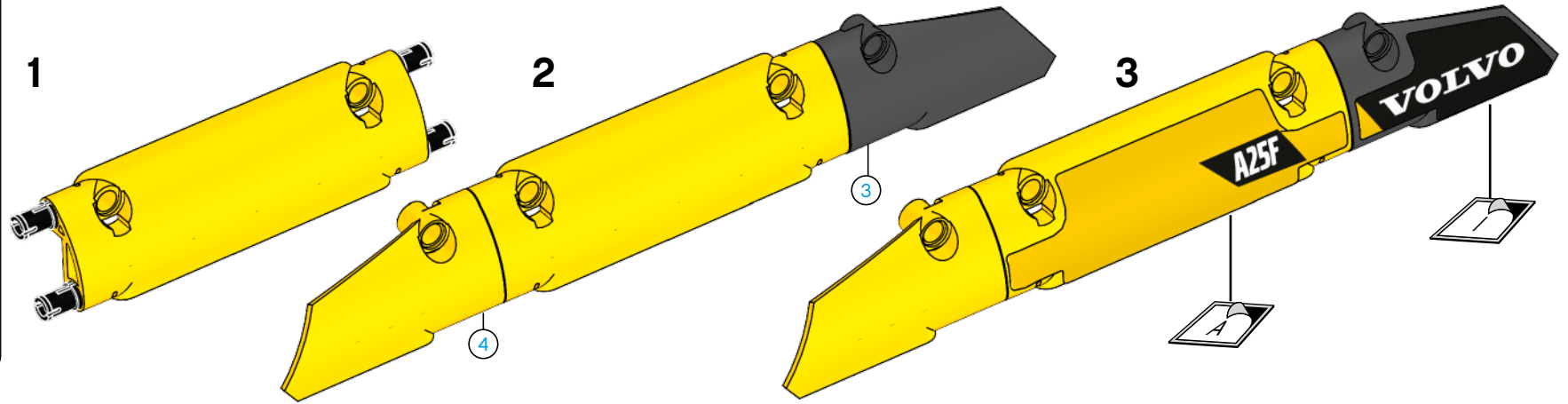
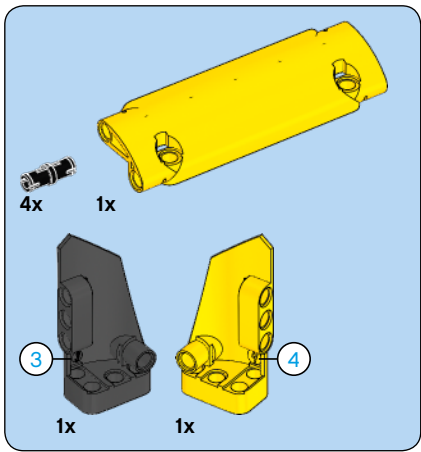

126

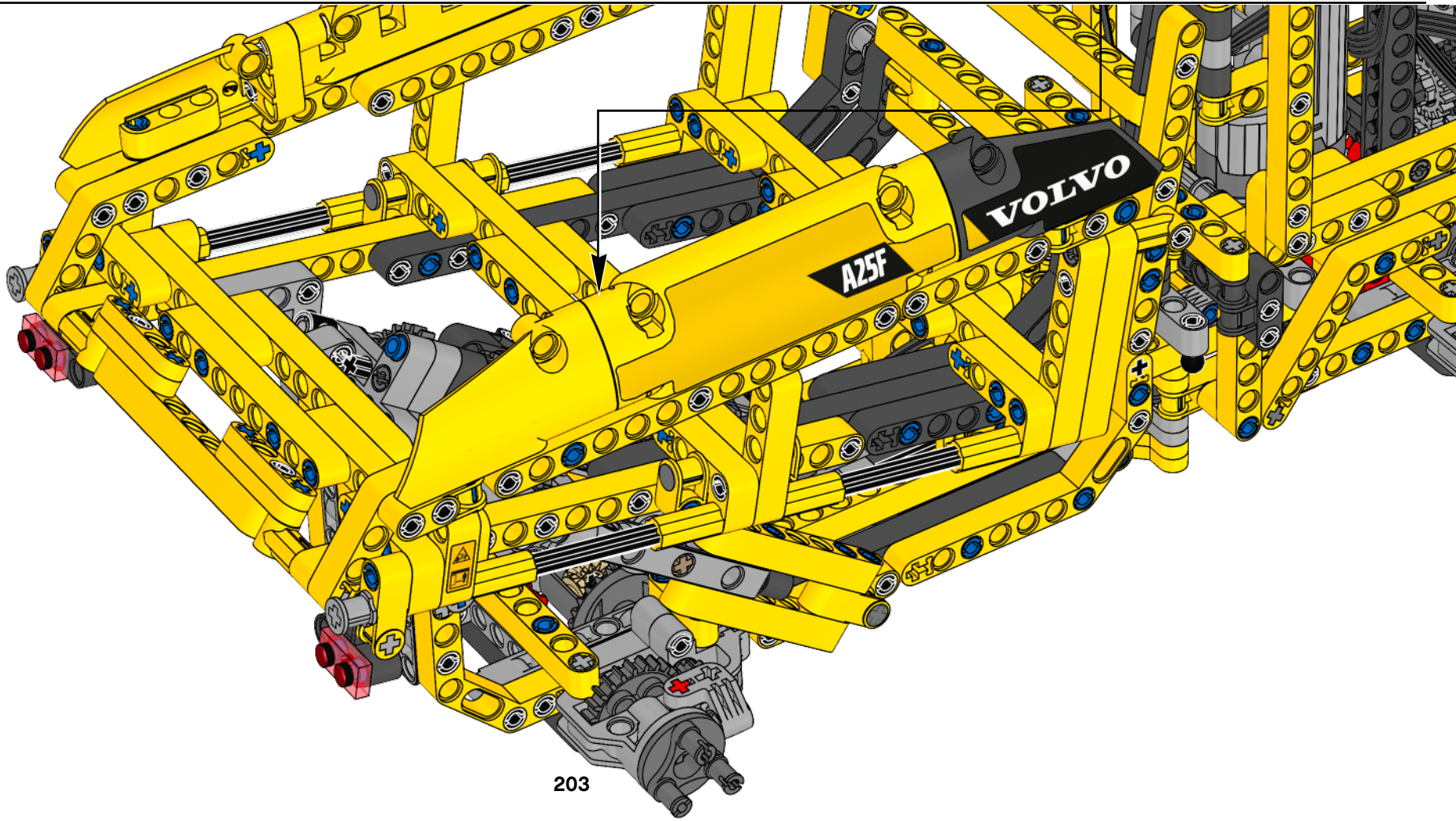

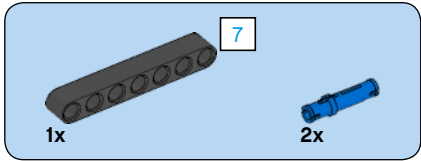
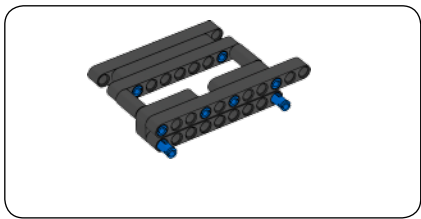

1

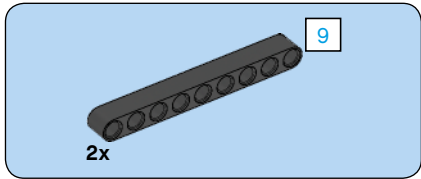
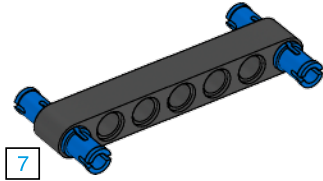

2

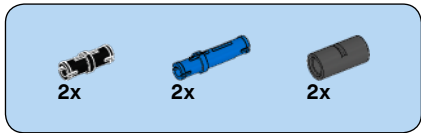
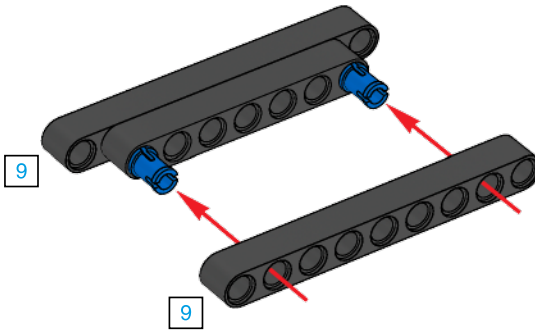

3

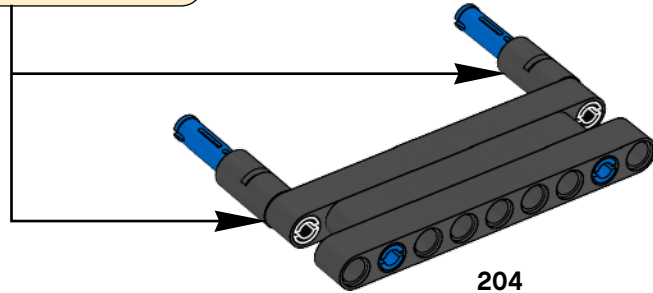
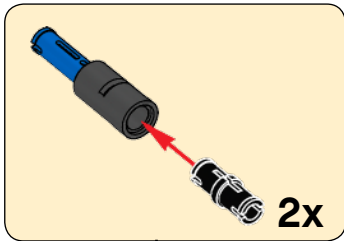

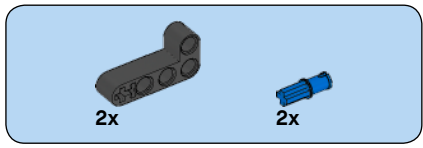

4

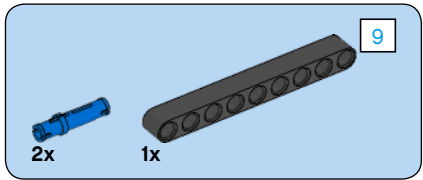
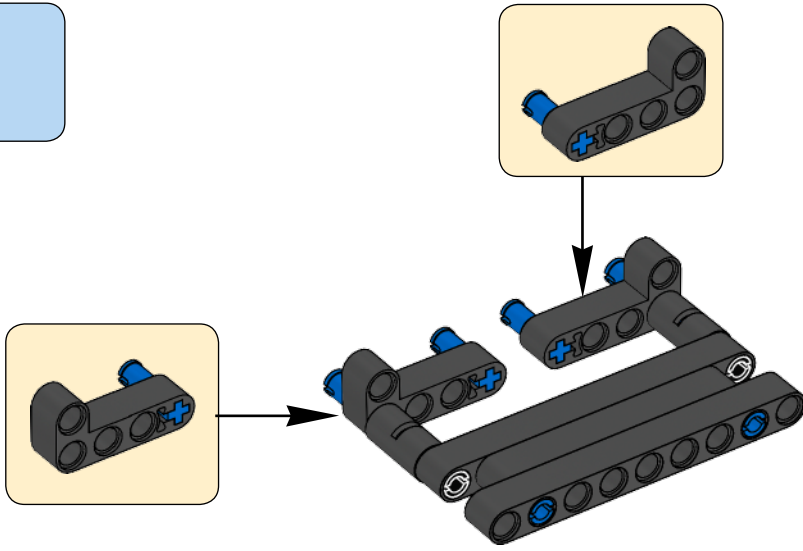

5

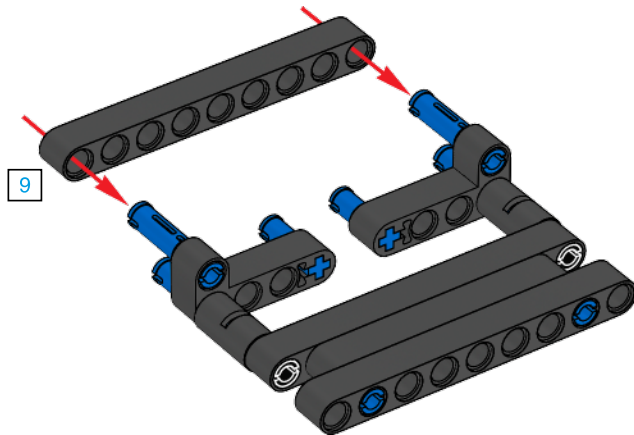

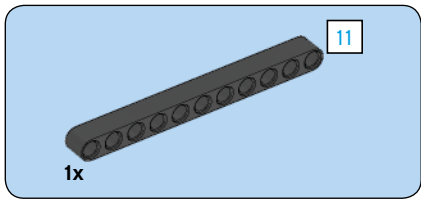

6

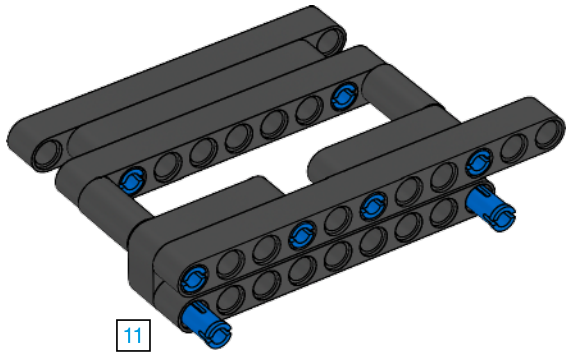
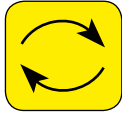

127

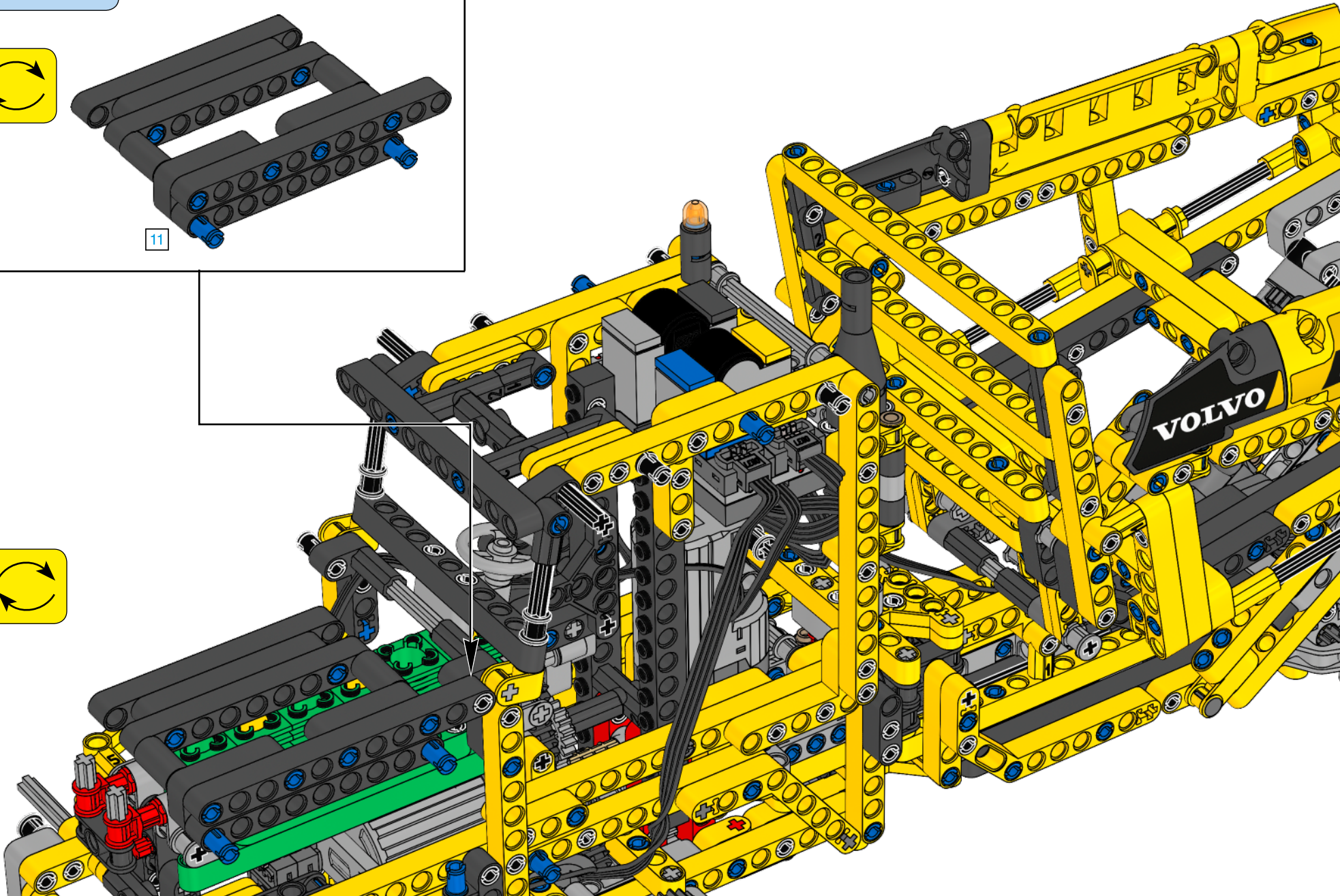

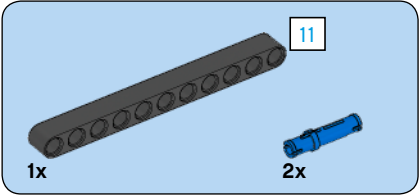
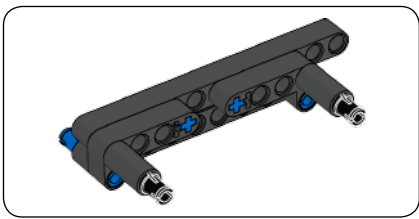

1

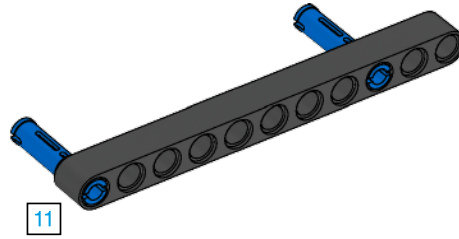

2

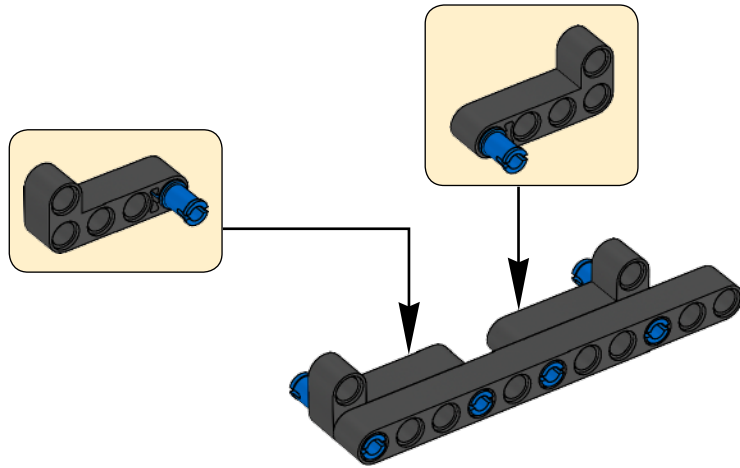

3

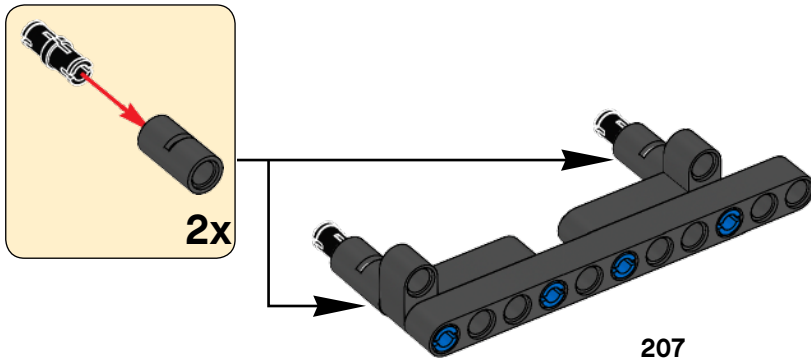

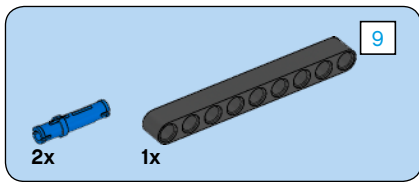

4

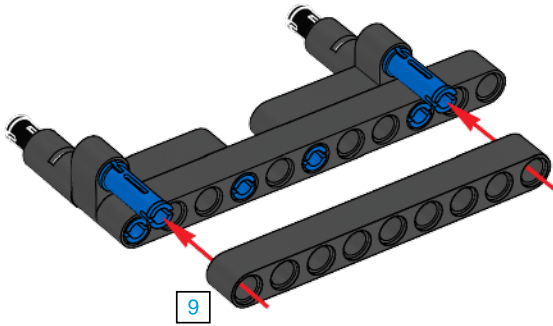

5

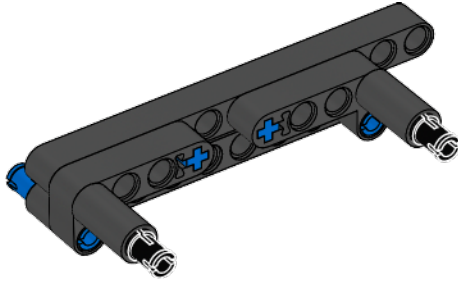

128

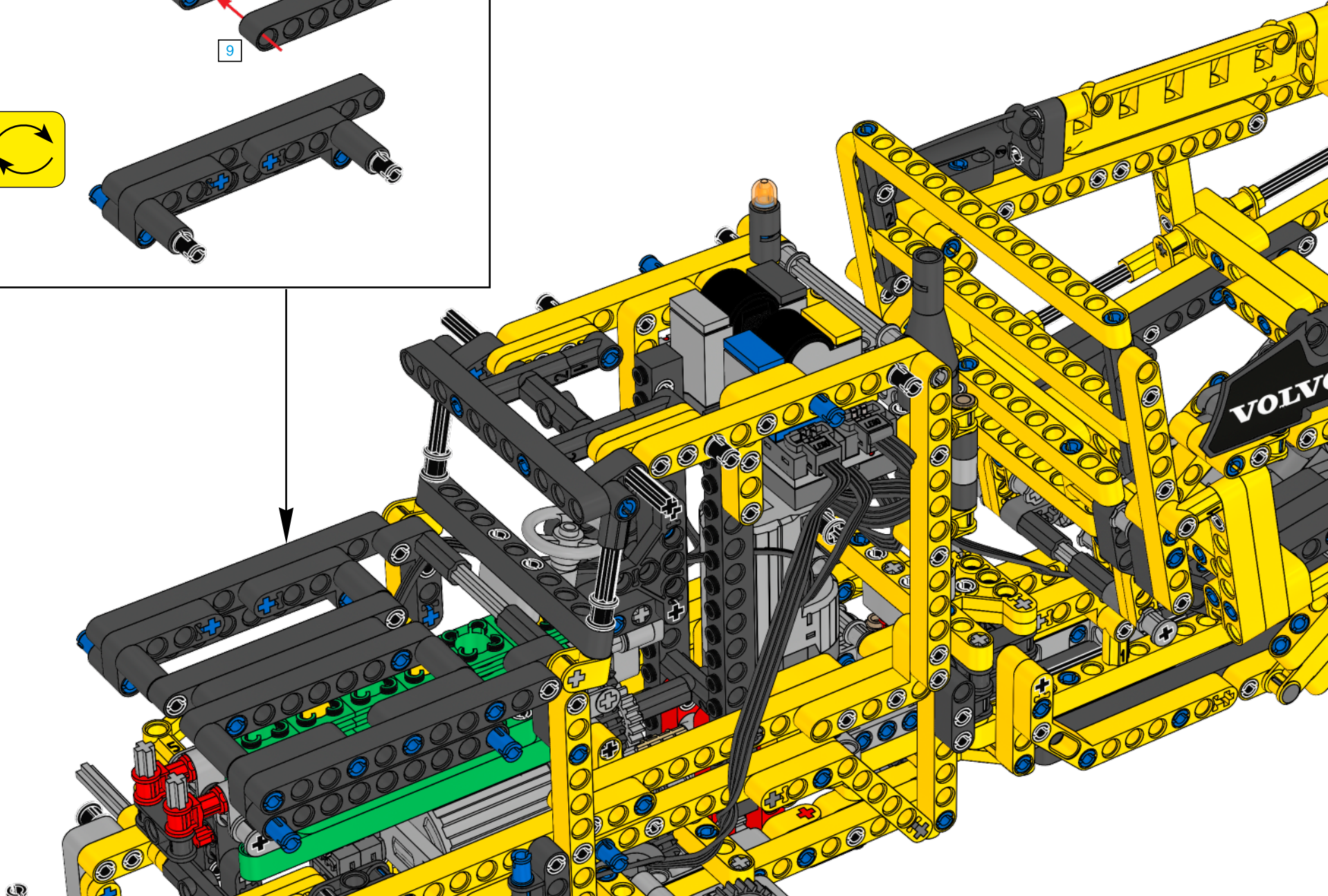

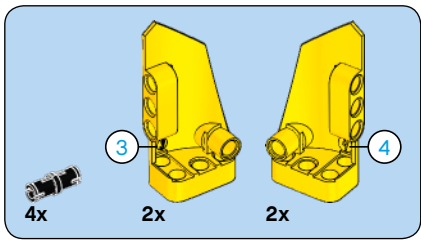

129

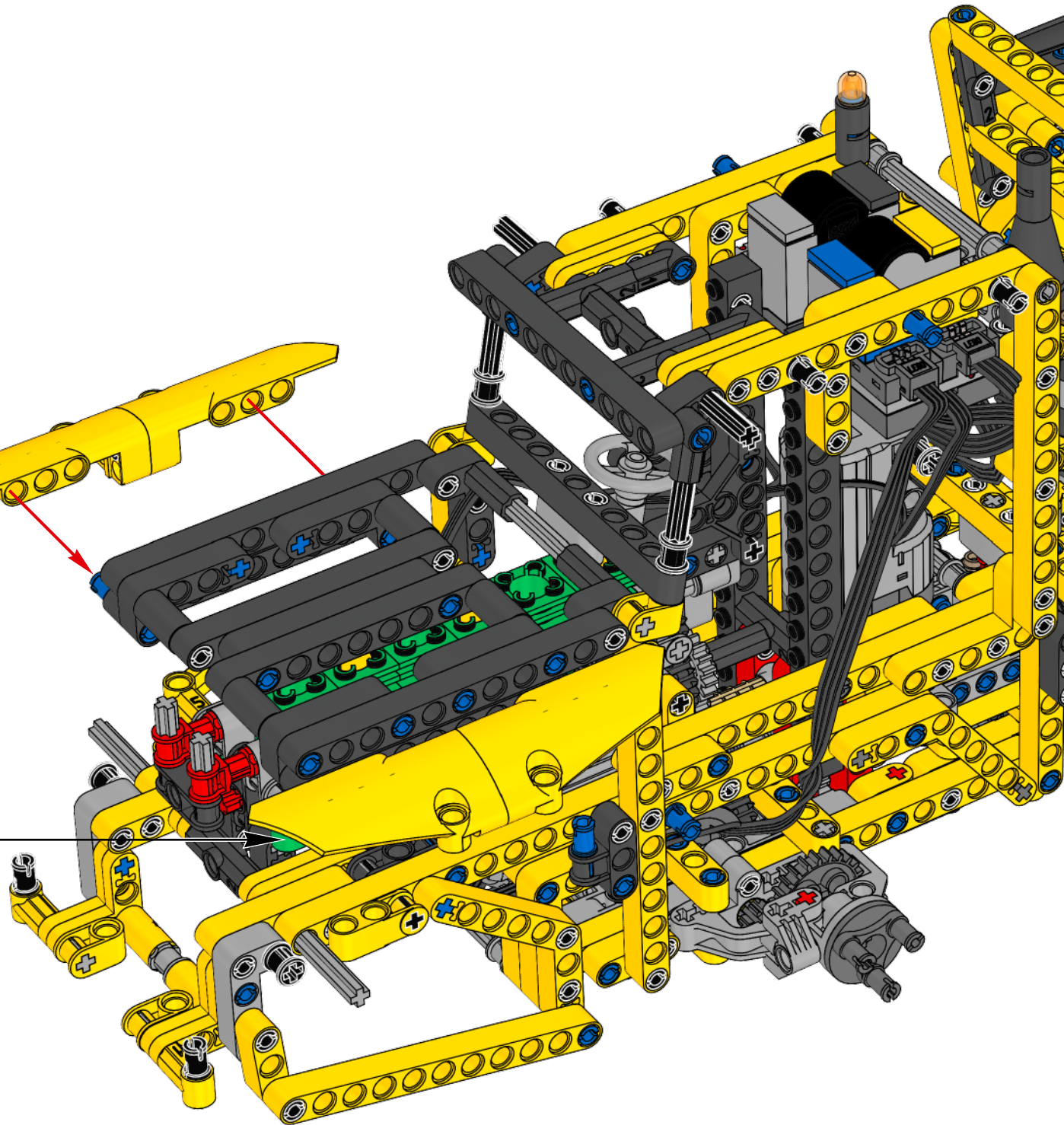
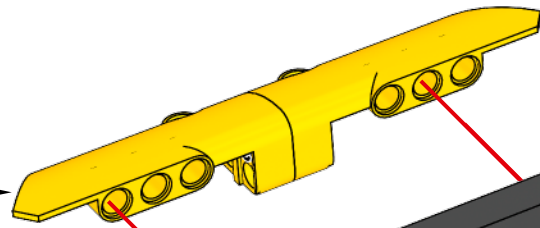
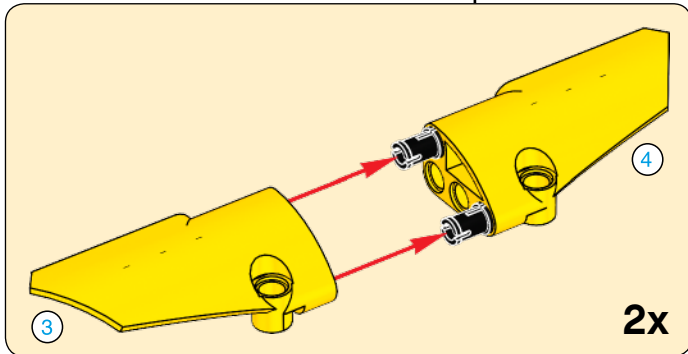

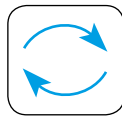
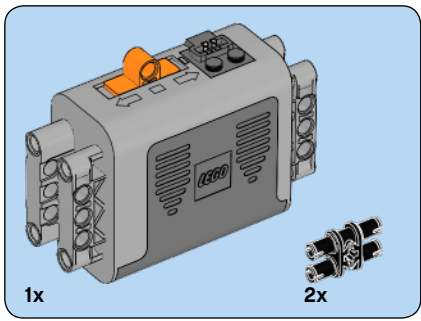

130

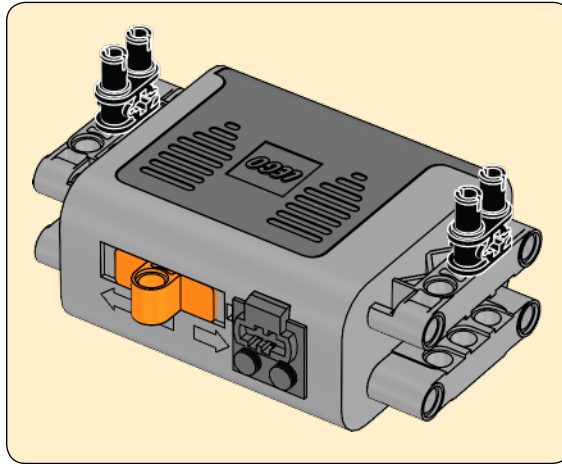
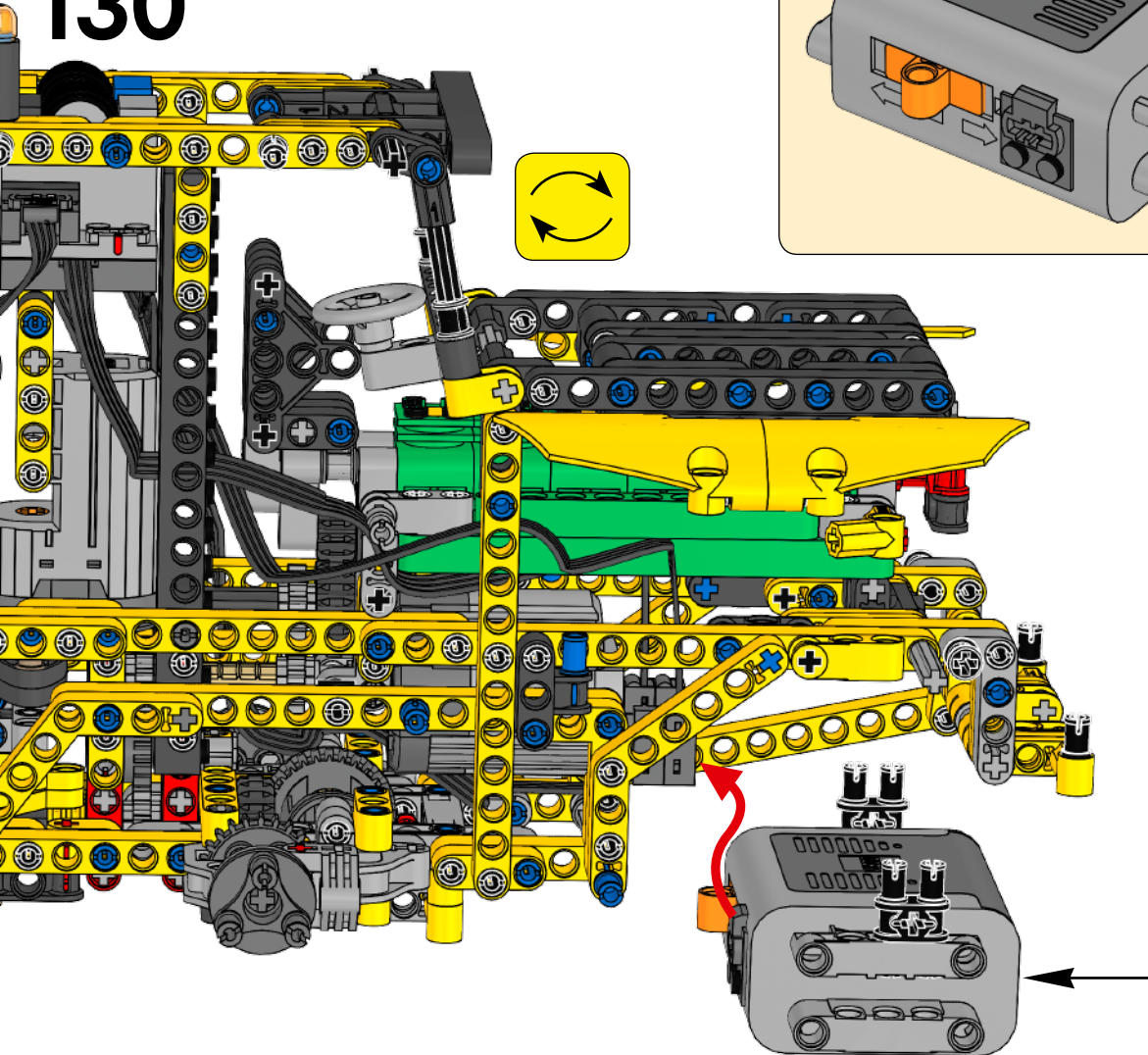

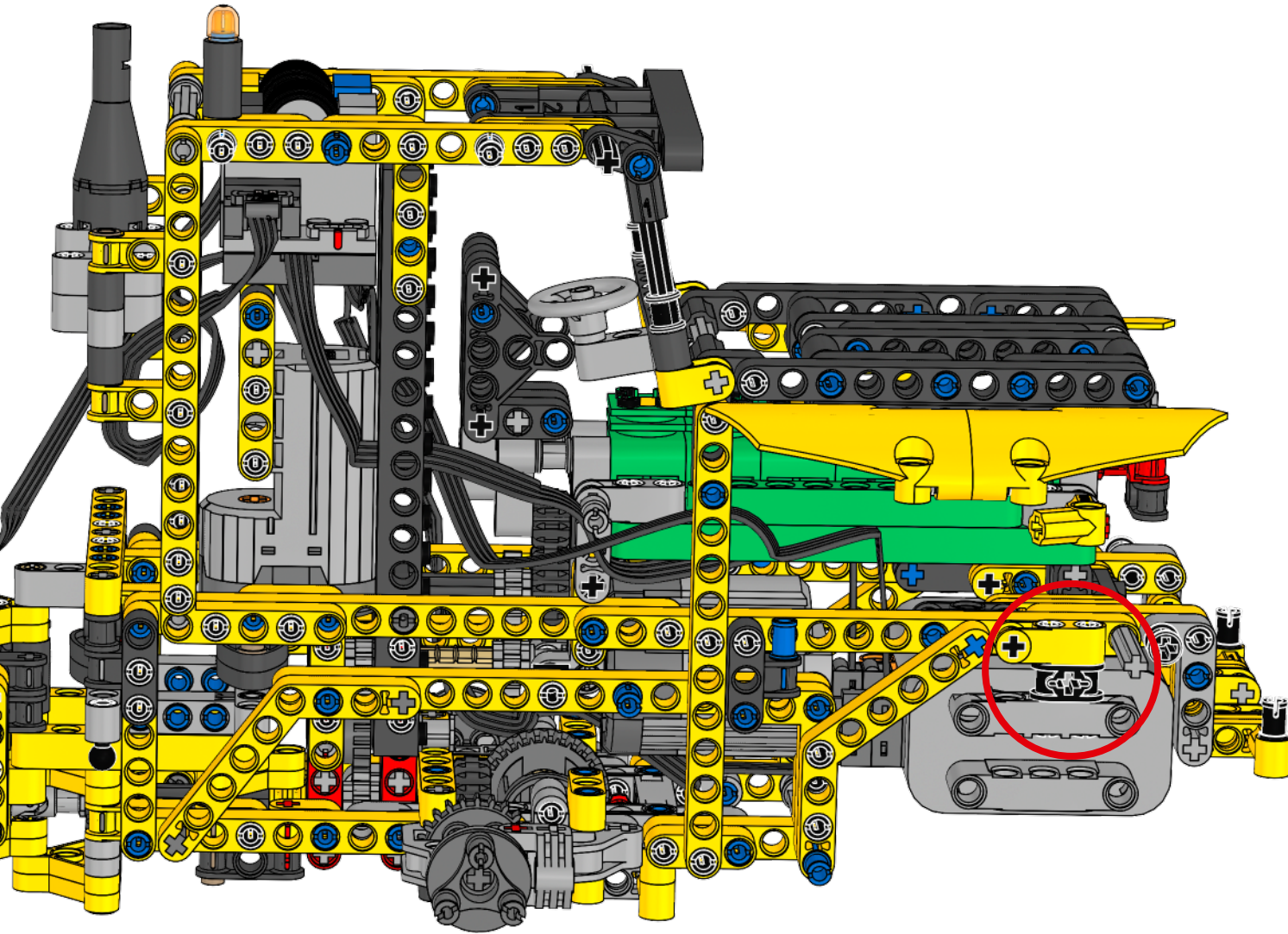

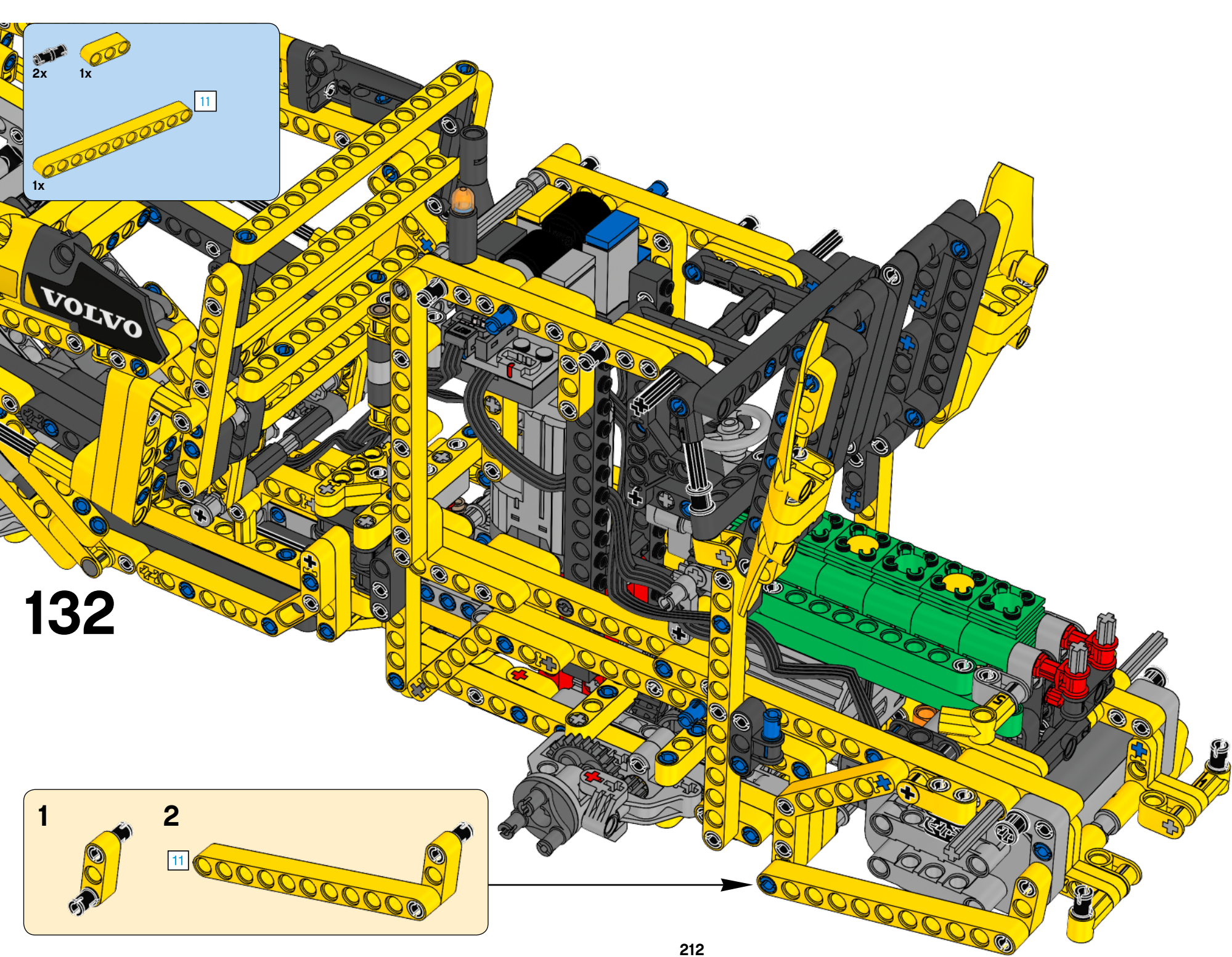

132

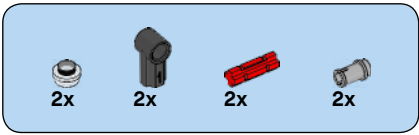

133

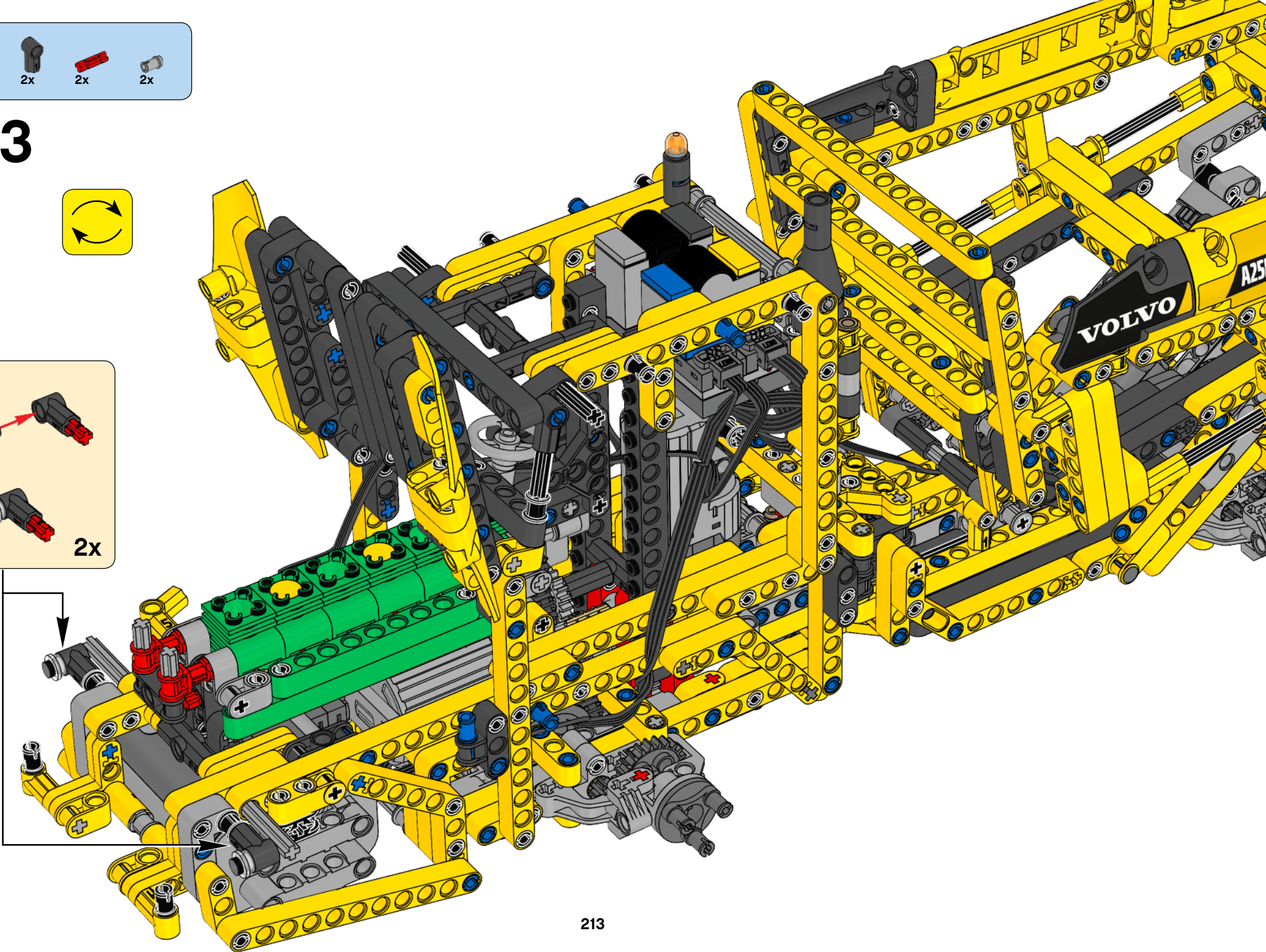
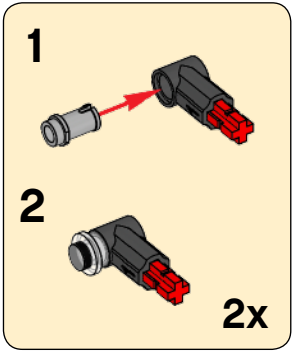
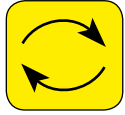

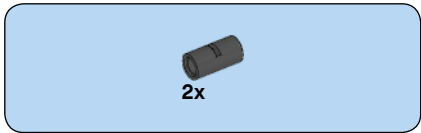

134

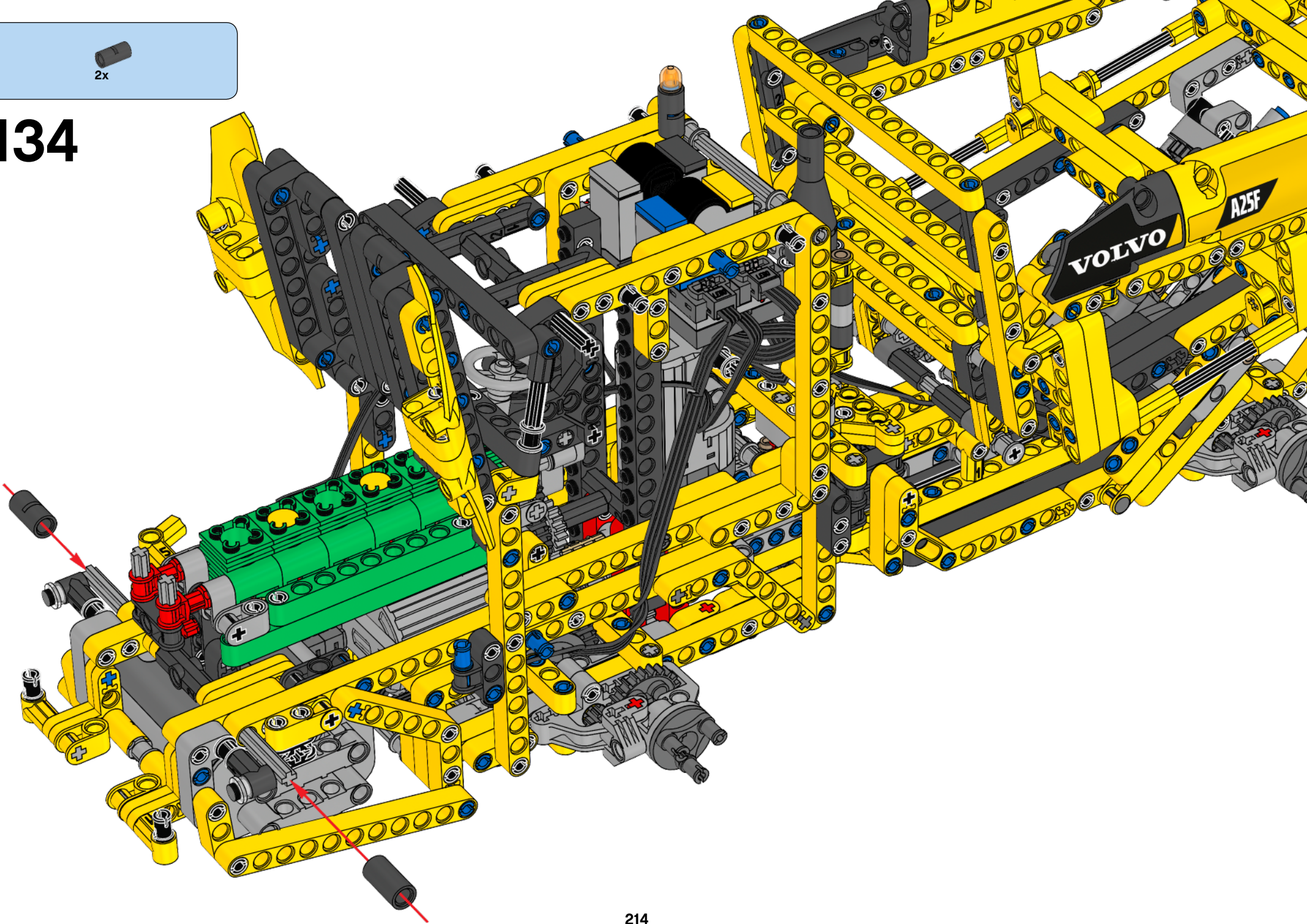

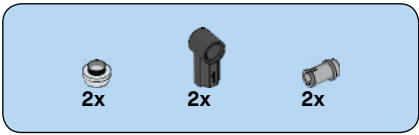

135

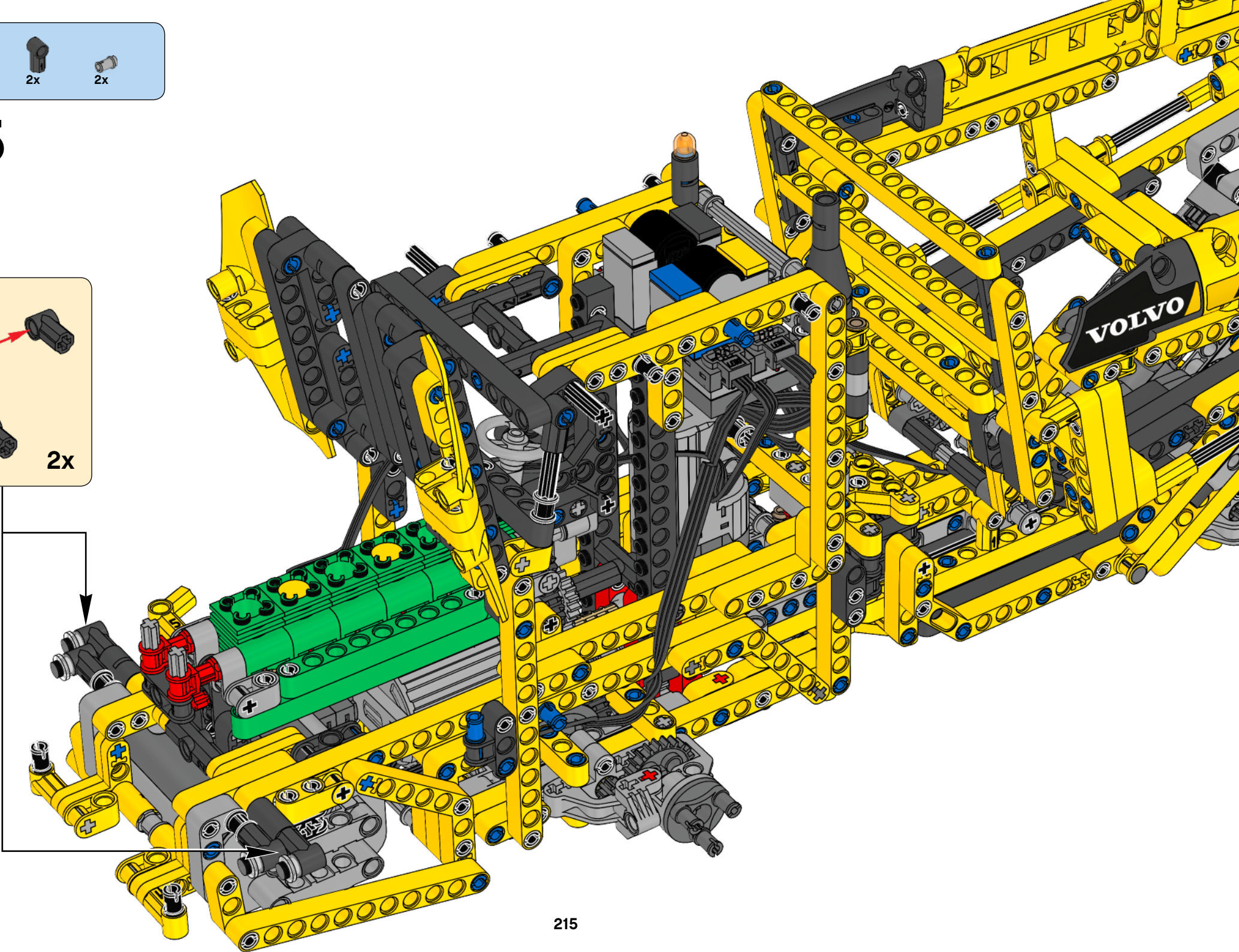
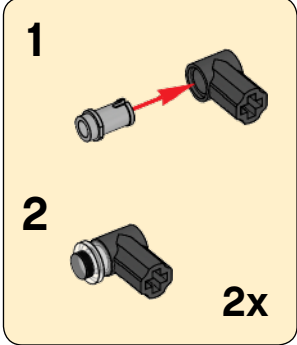

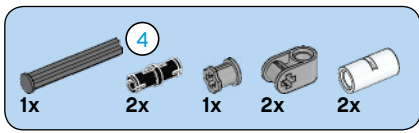

136

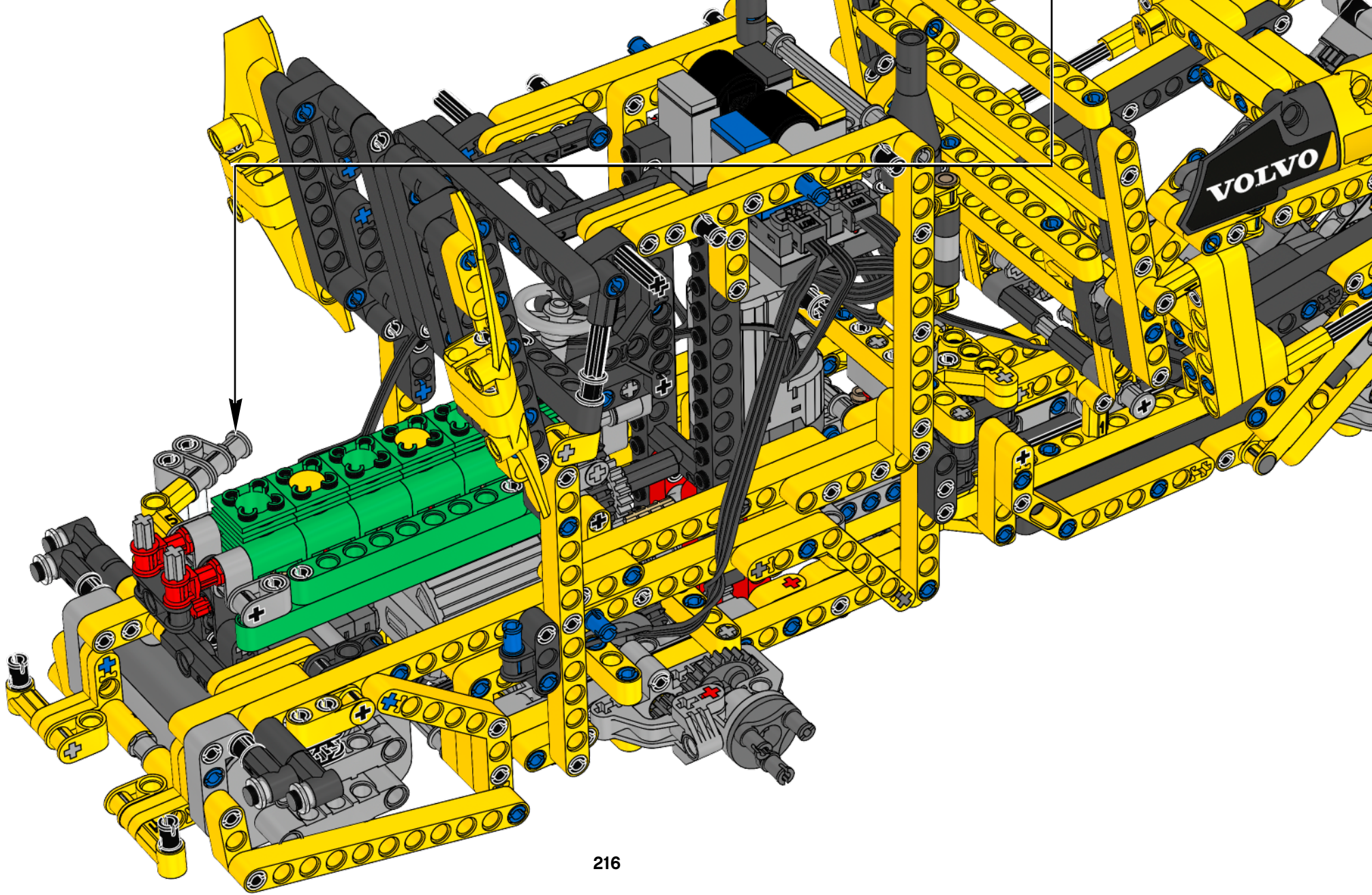
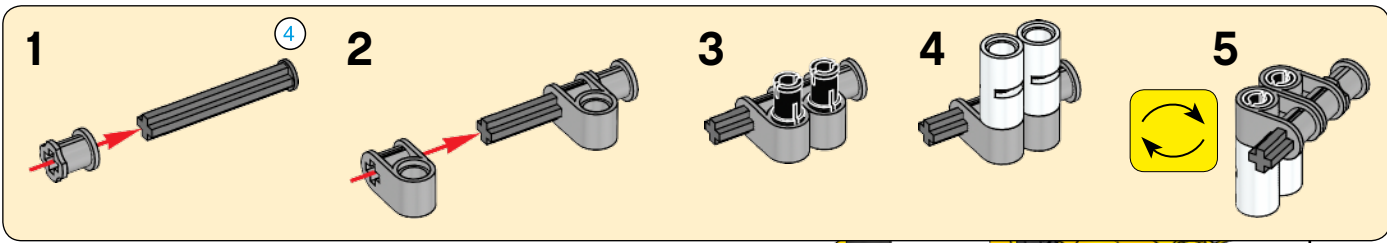

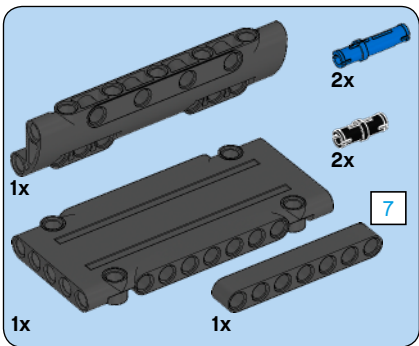

137

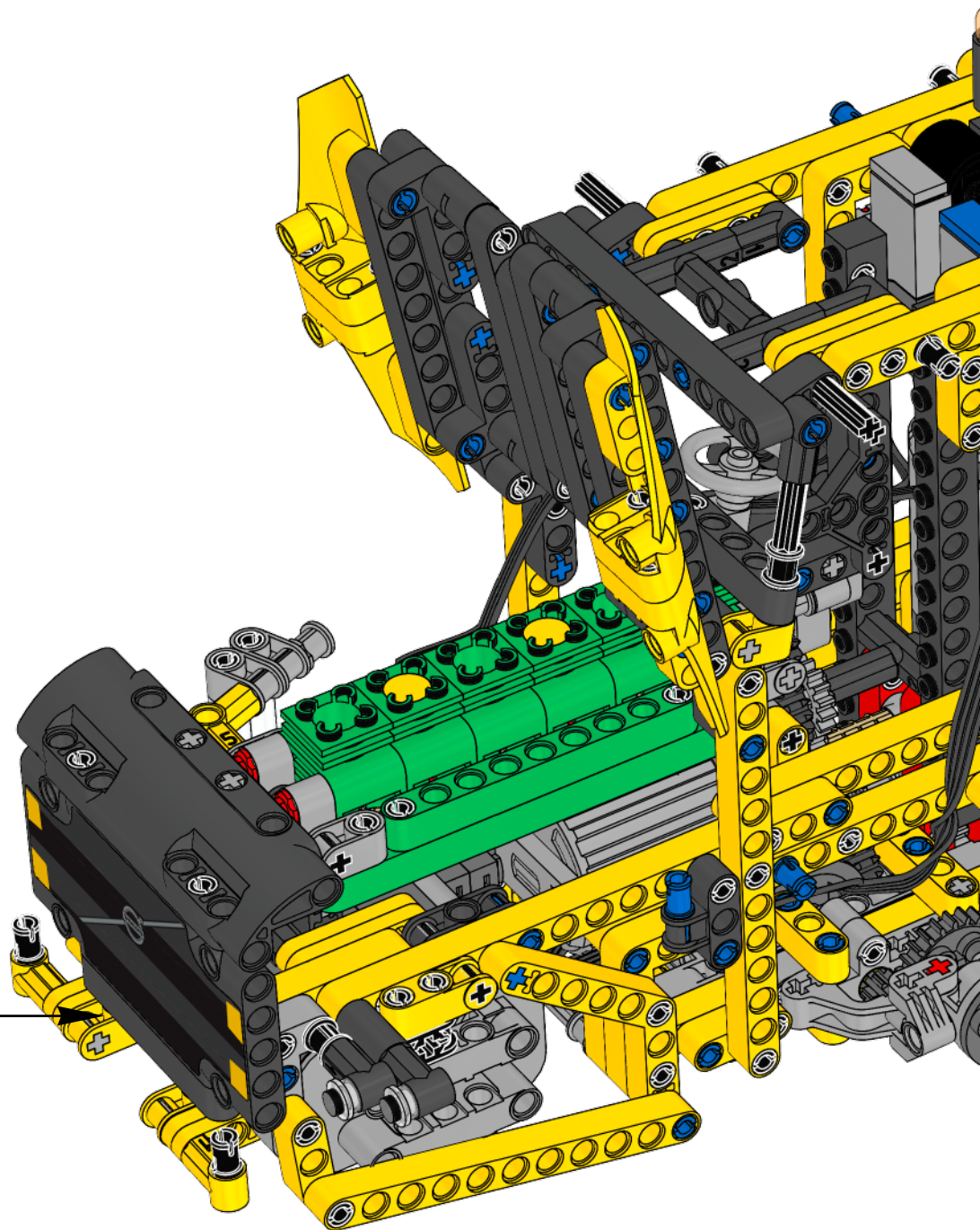
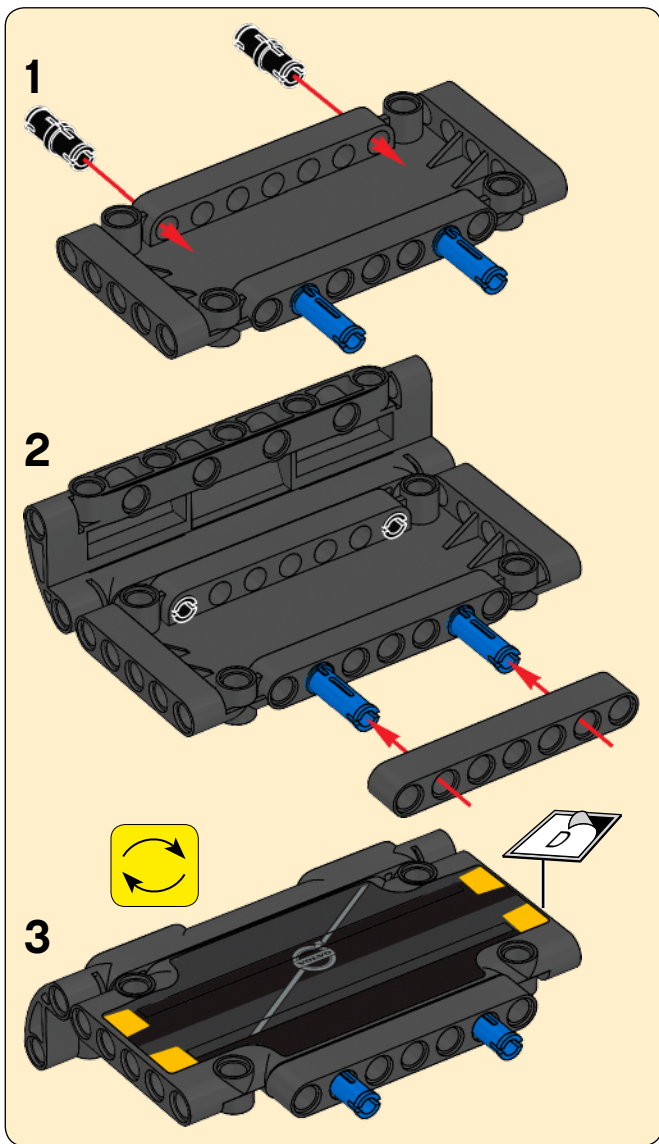

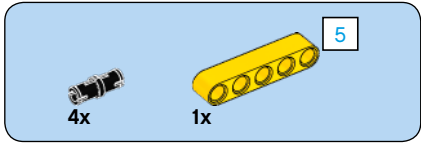
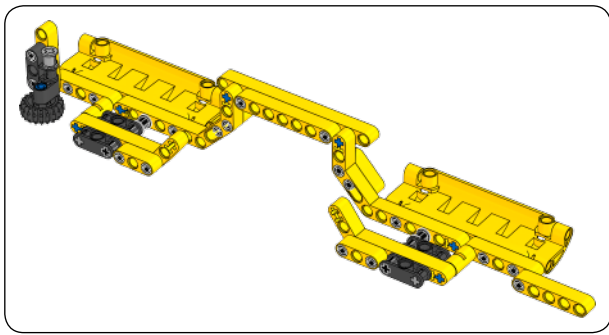

1

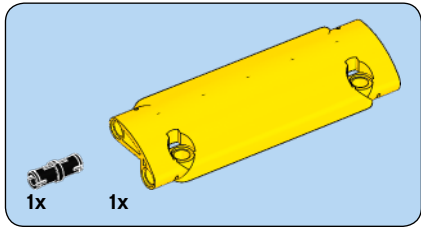
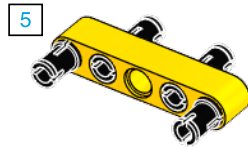

2

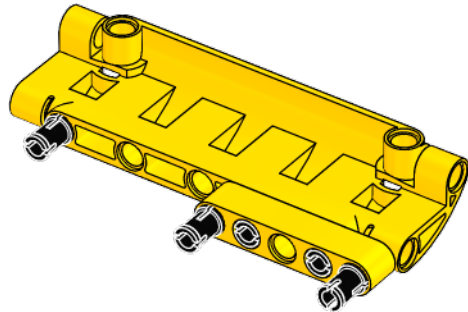

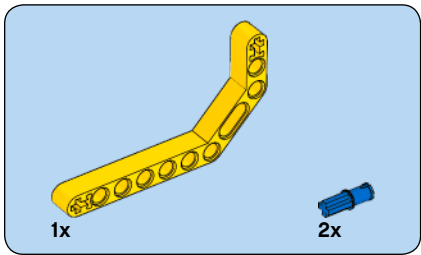

3

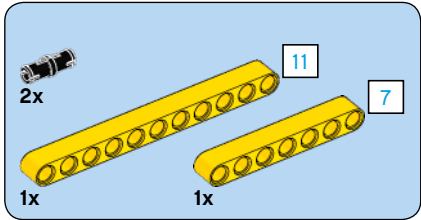
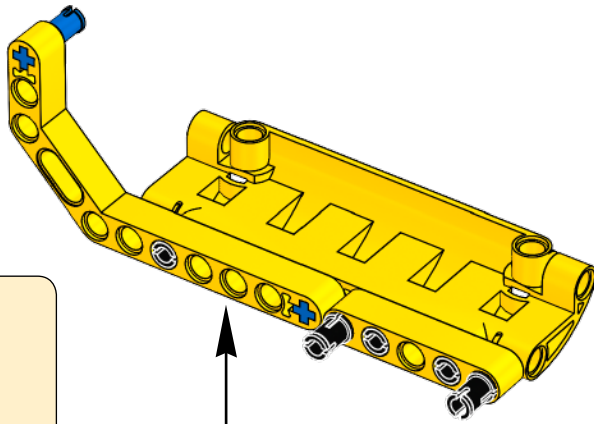
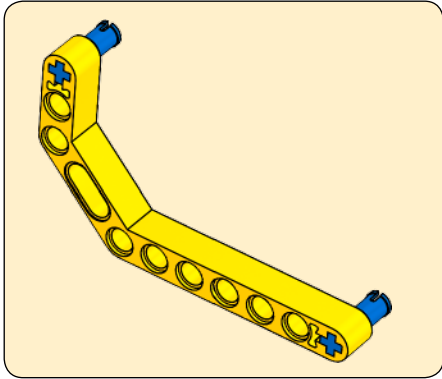

4

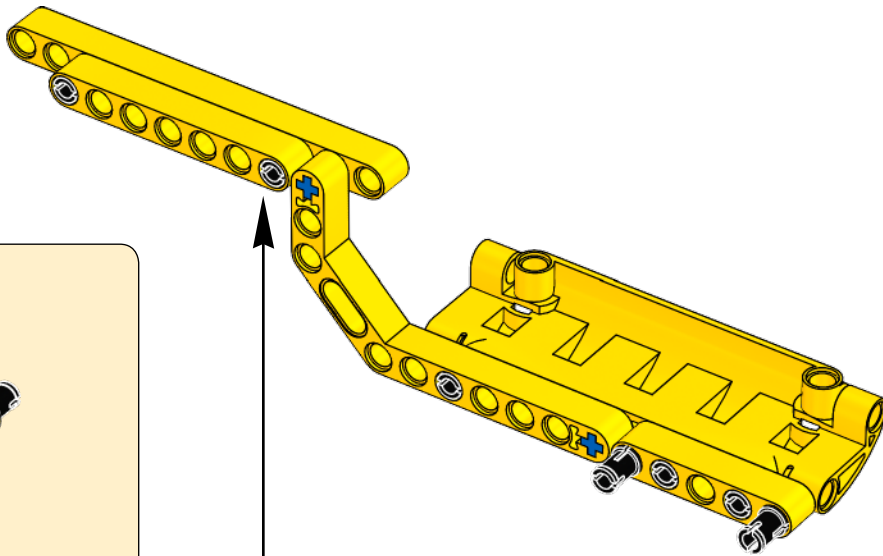
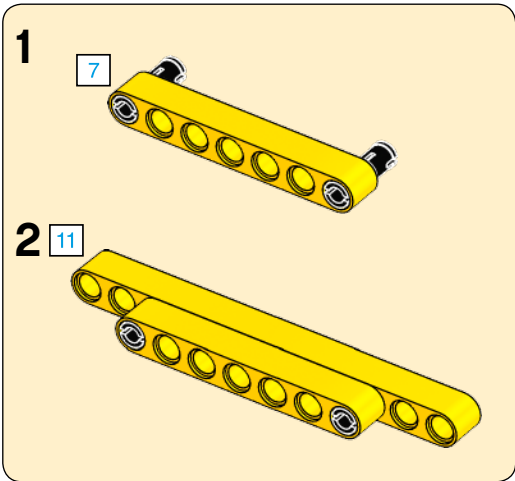

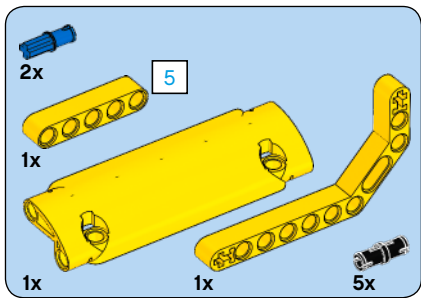

5

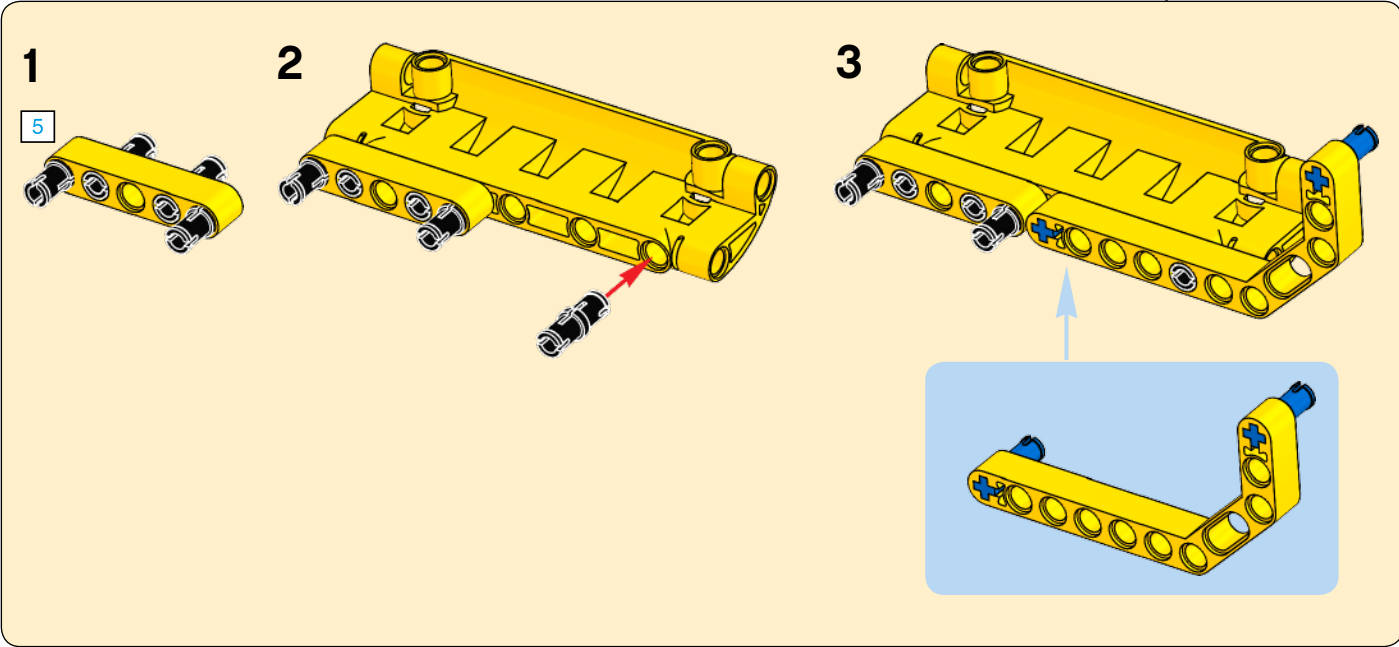
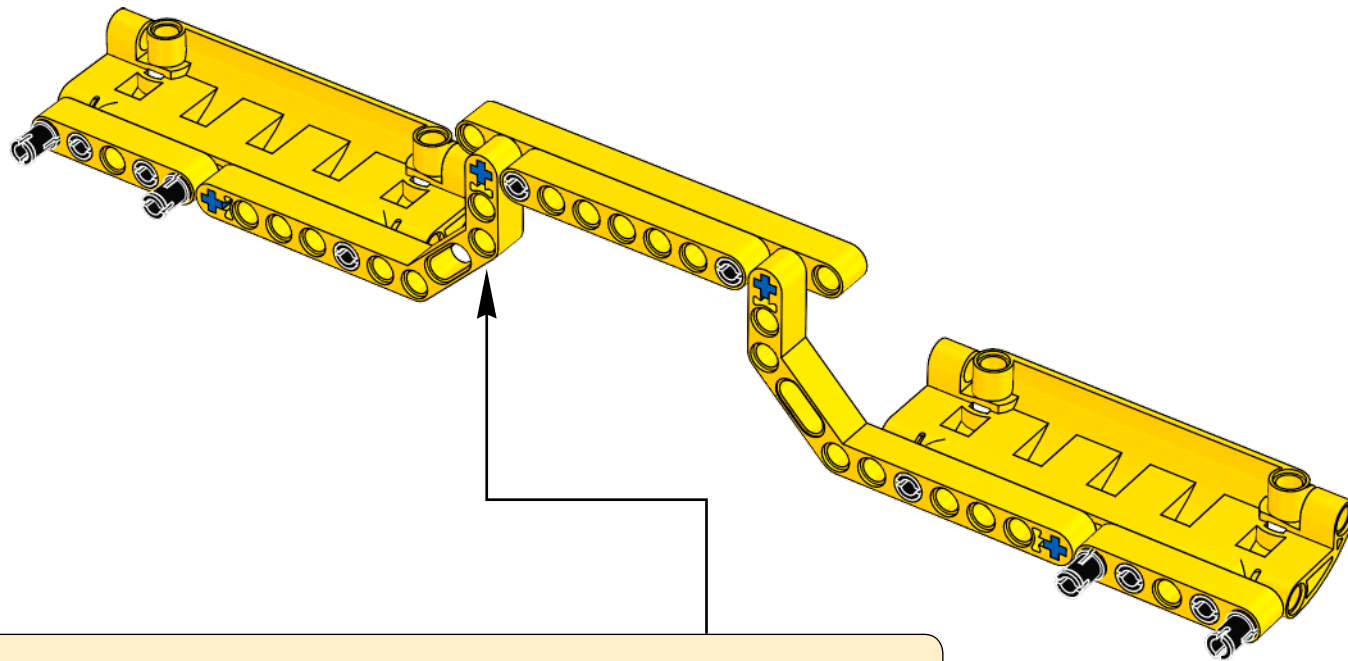

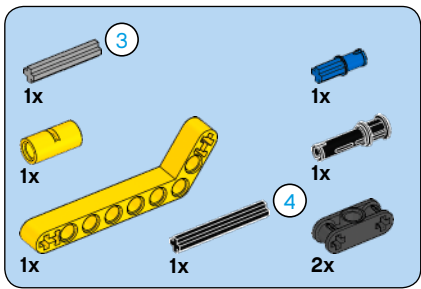

6

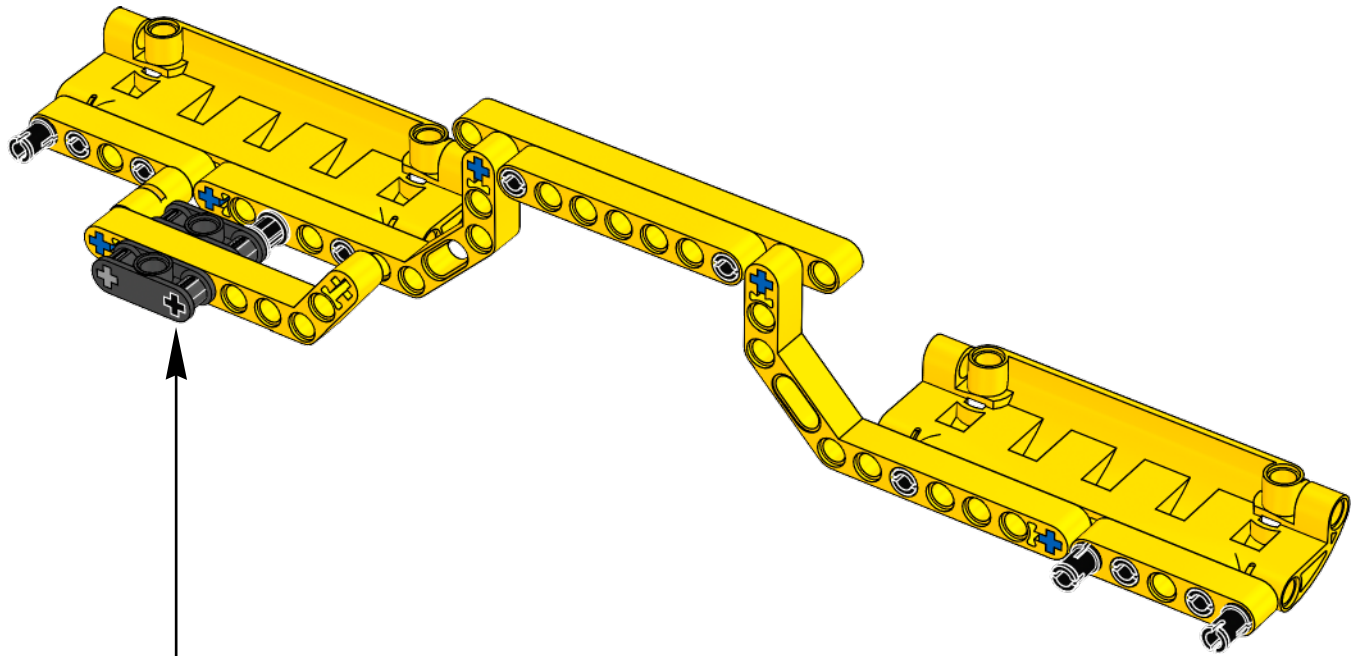
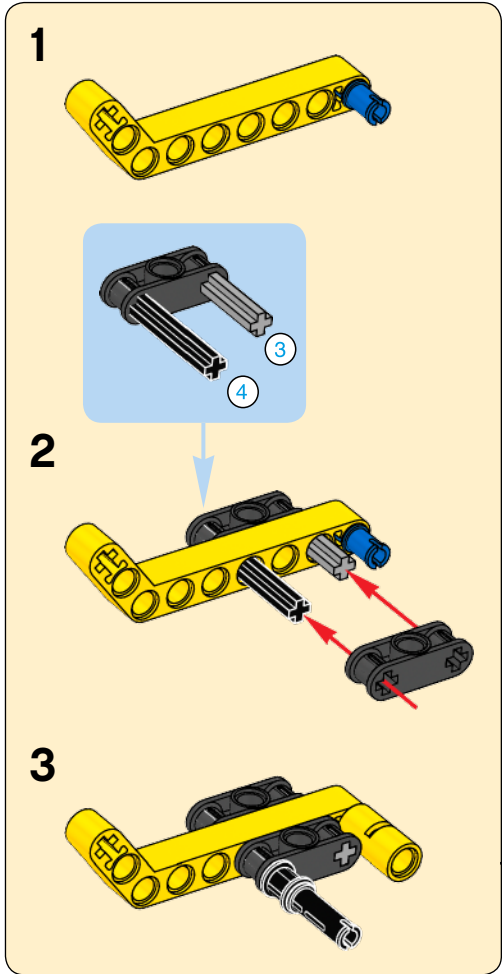

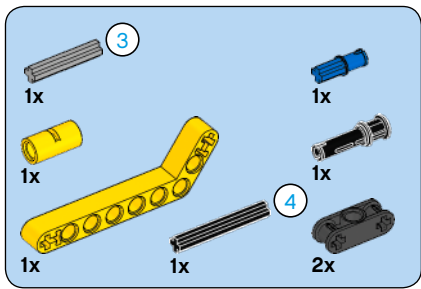

7

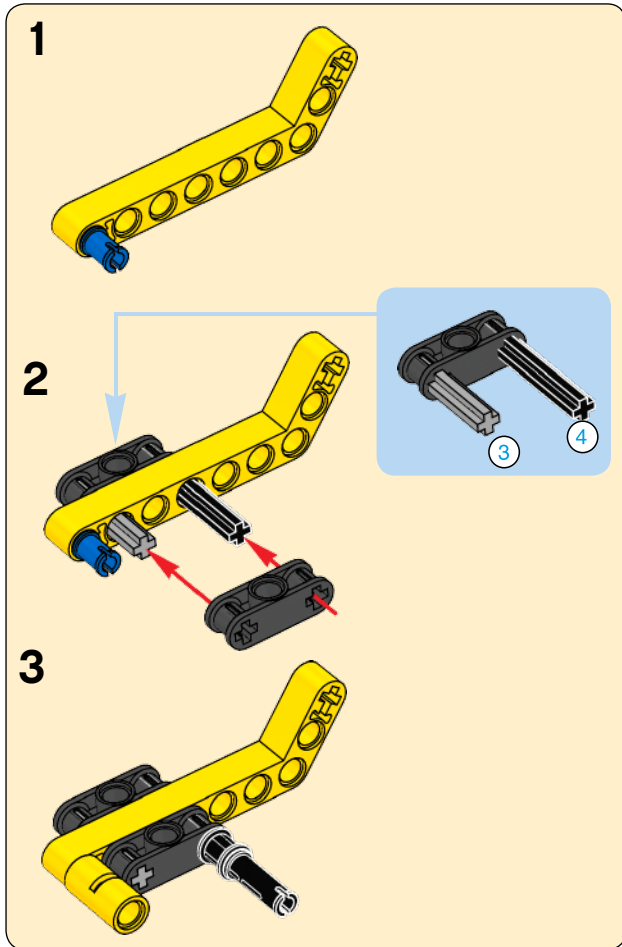
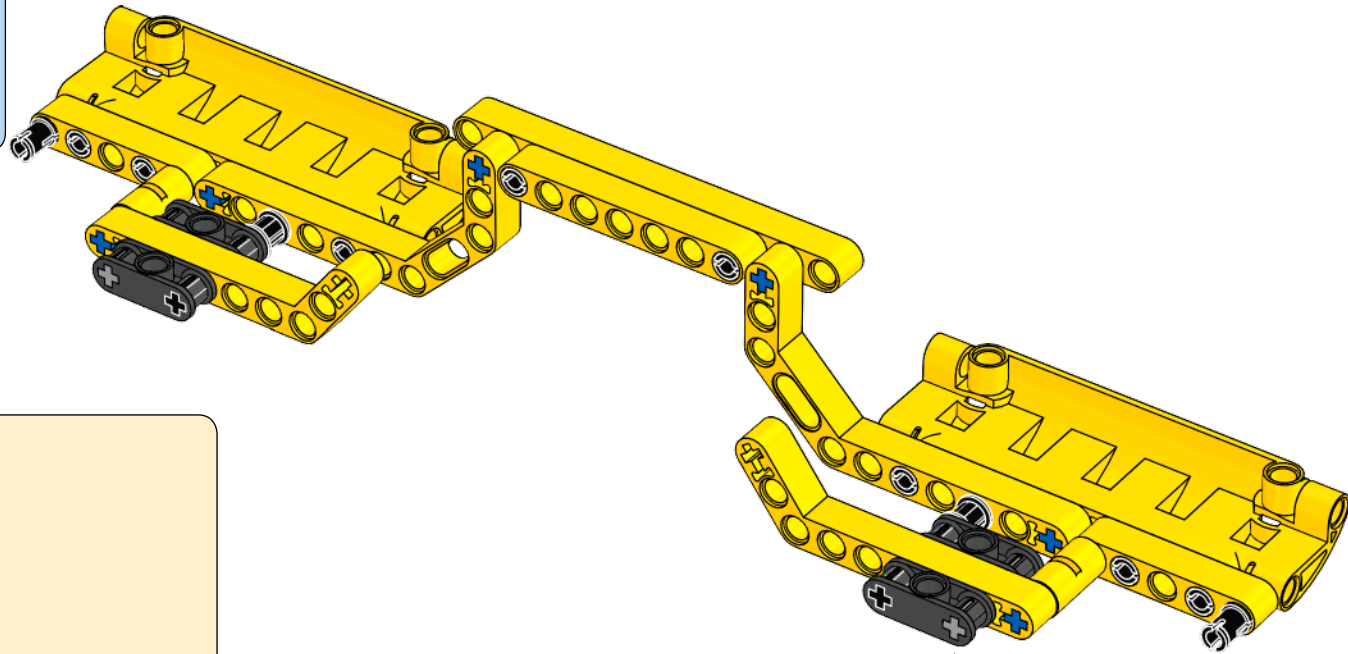

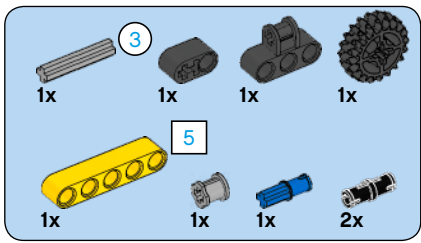

8

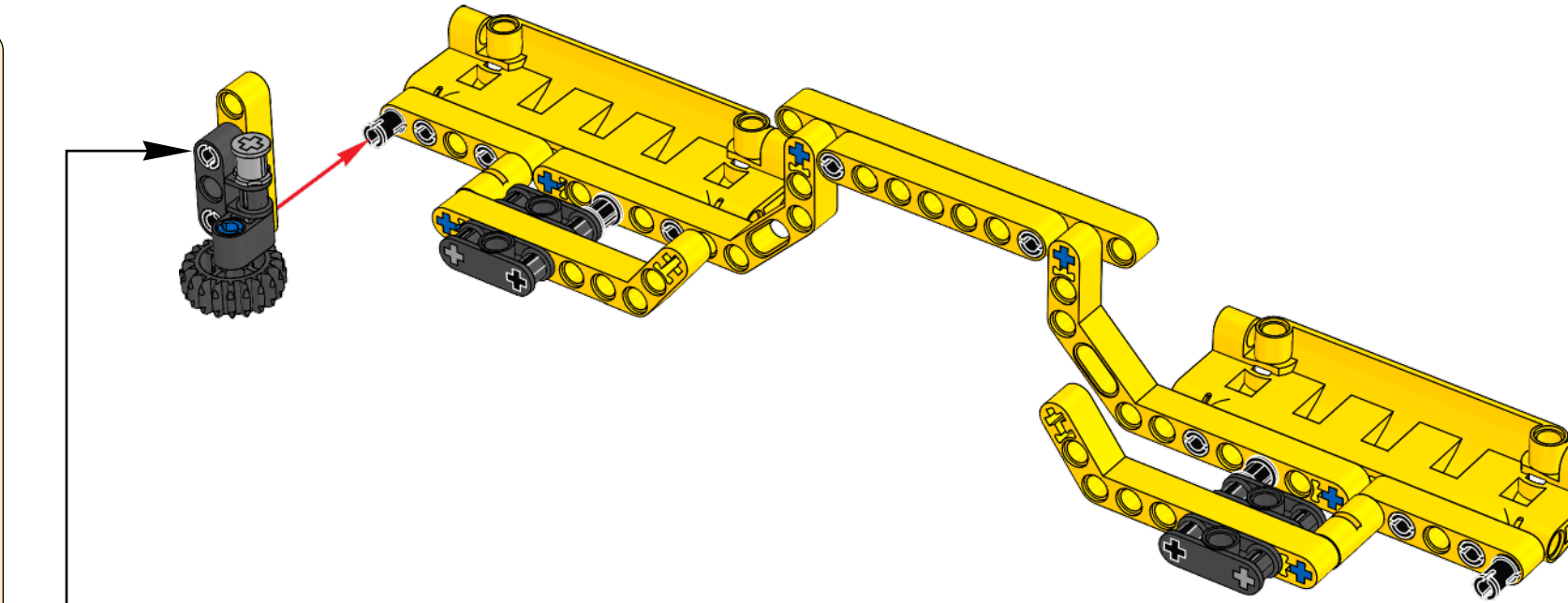
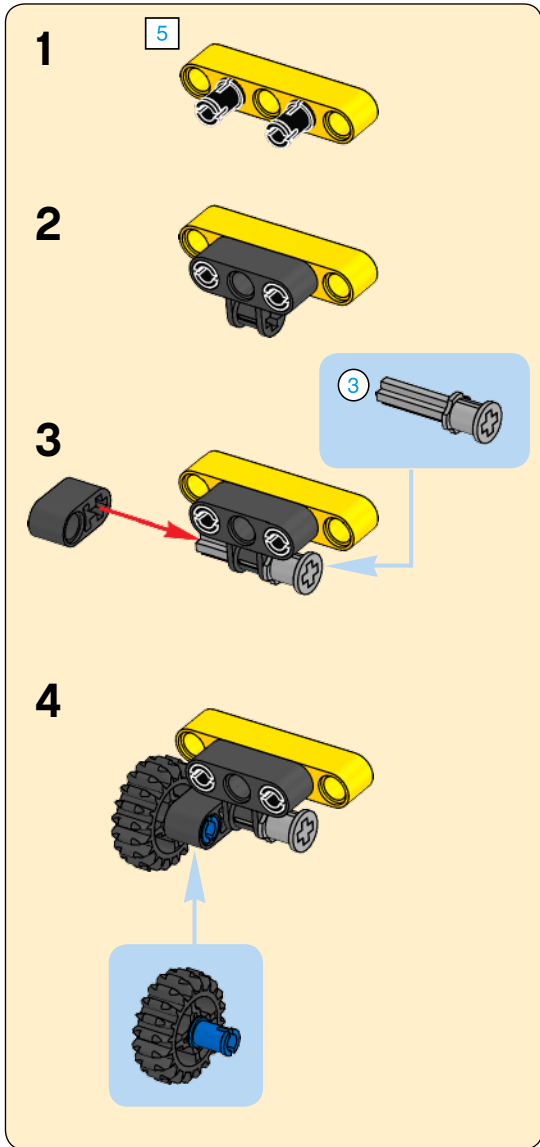

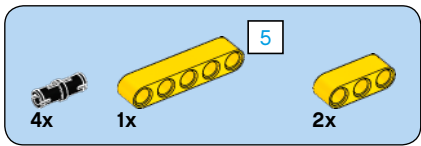

9

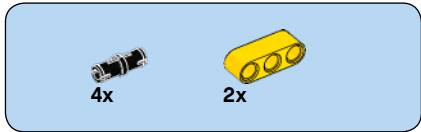
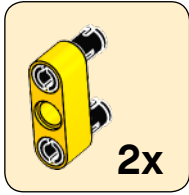
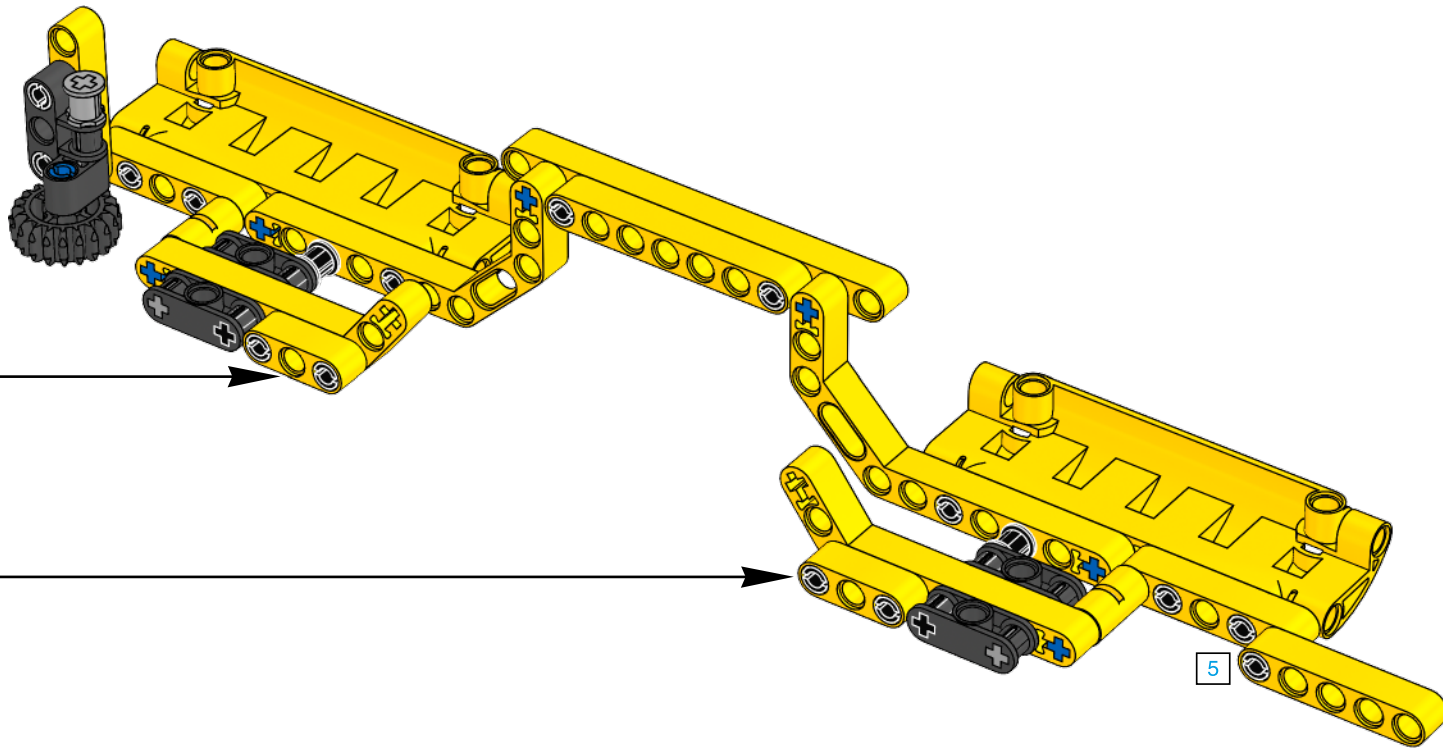

10

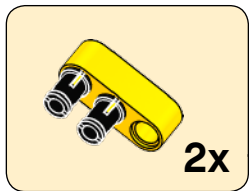
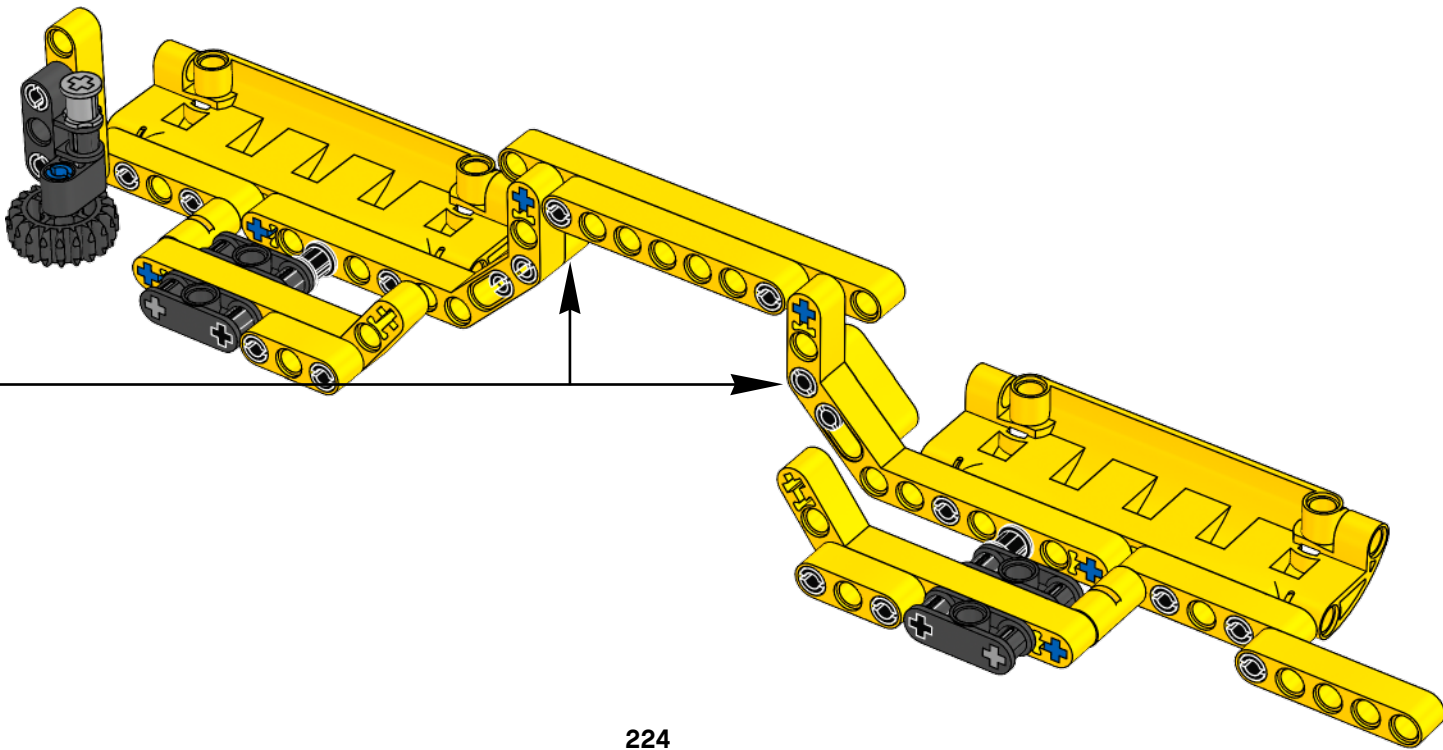

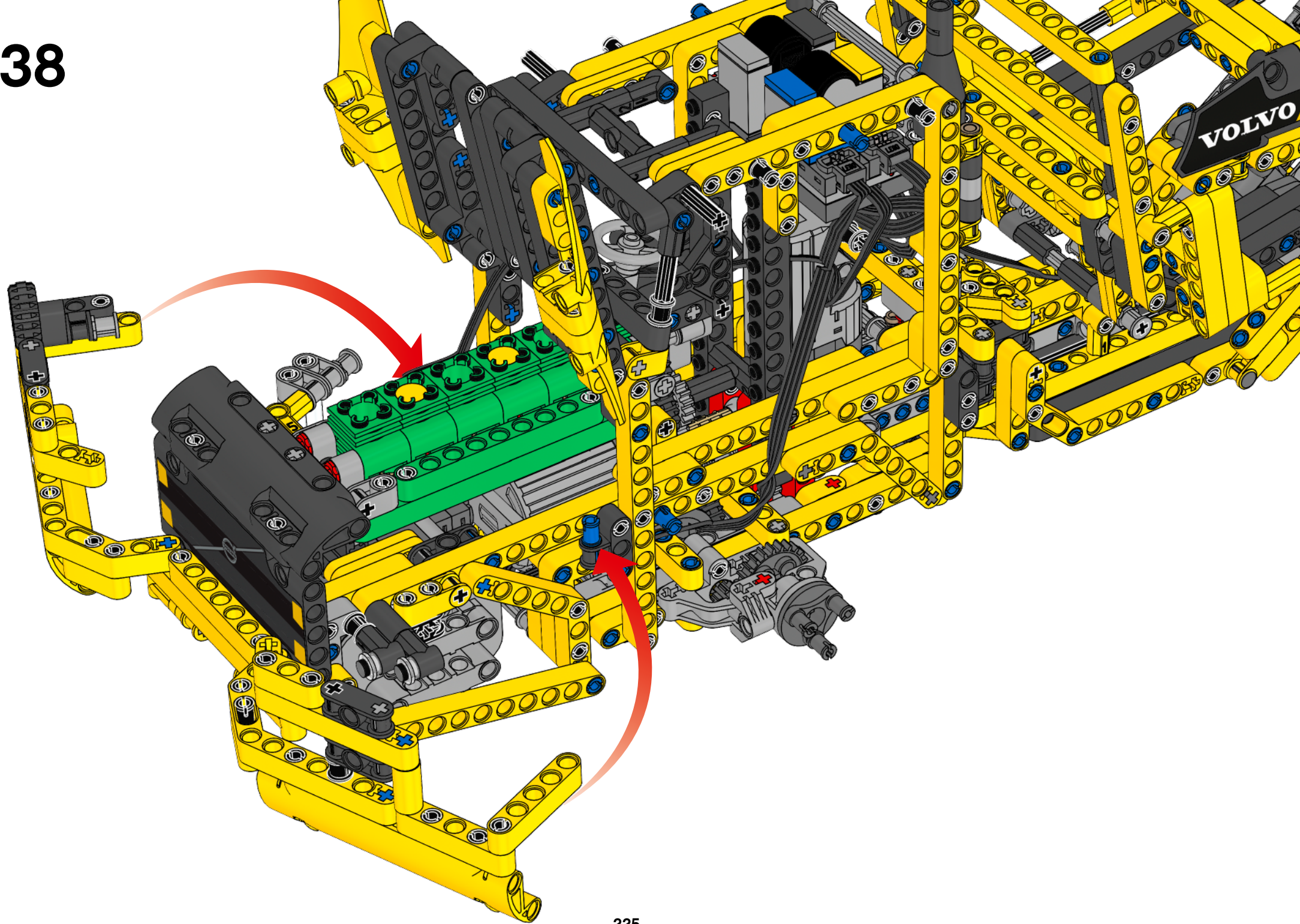

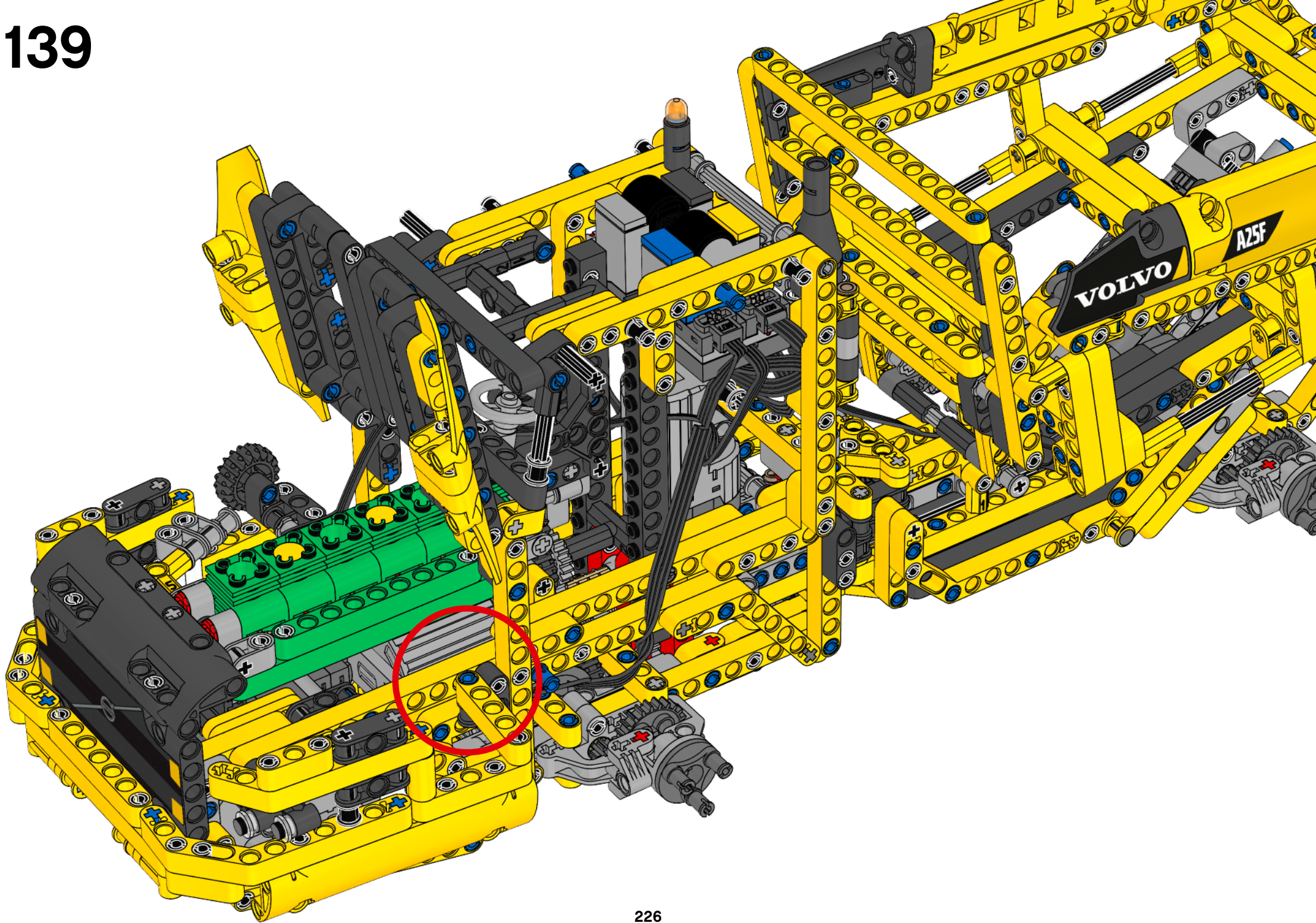

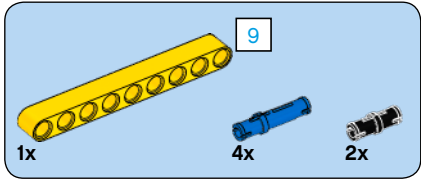

1

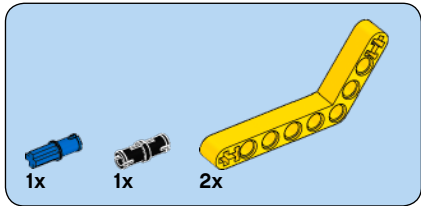
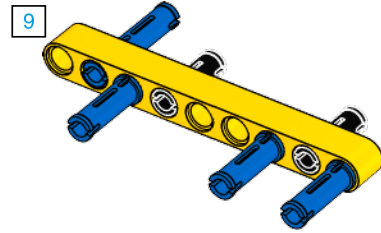

2

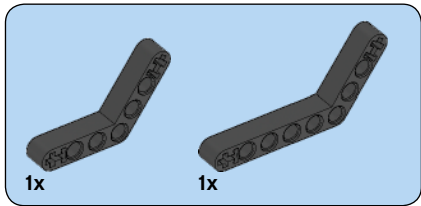
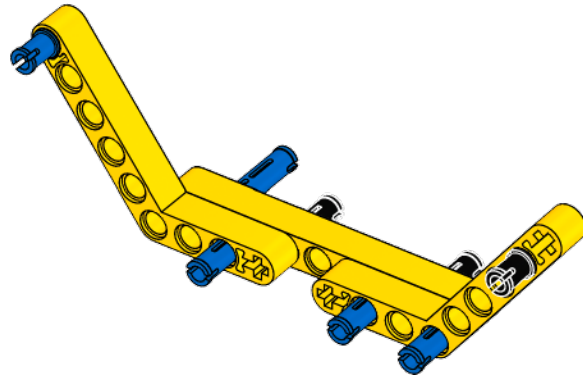

3

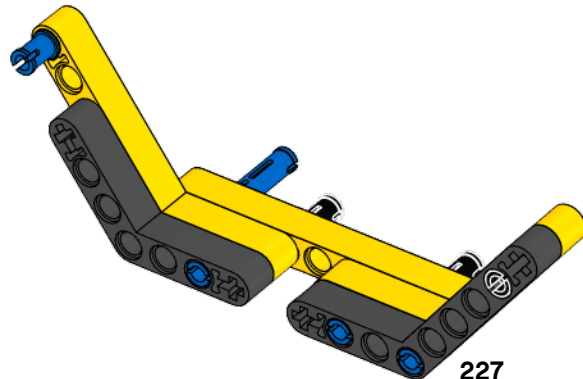

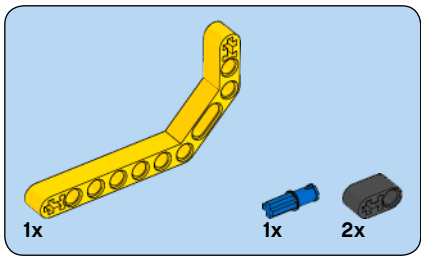

4

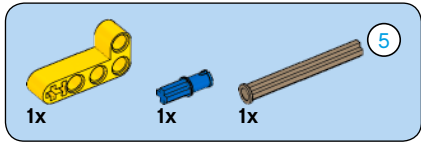
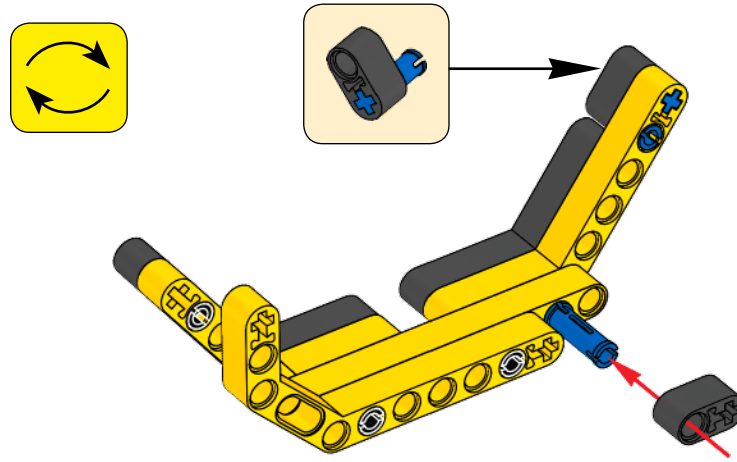

5

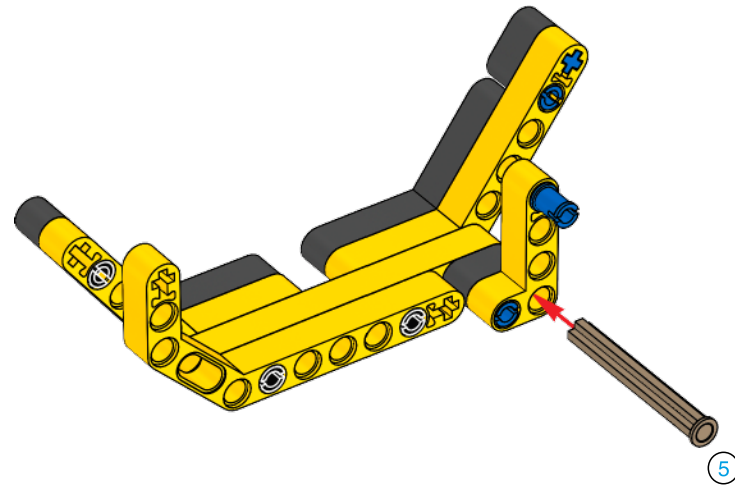

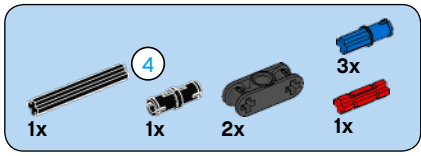

6

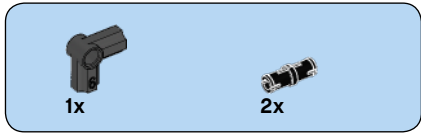
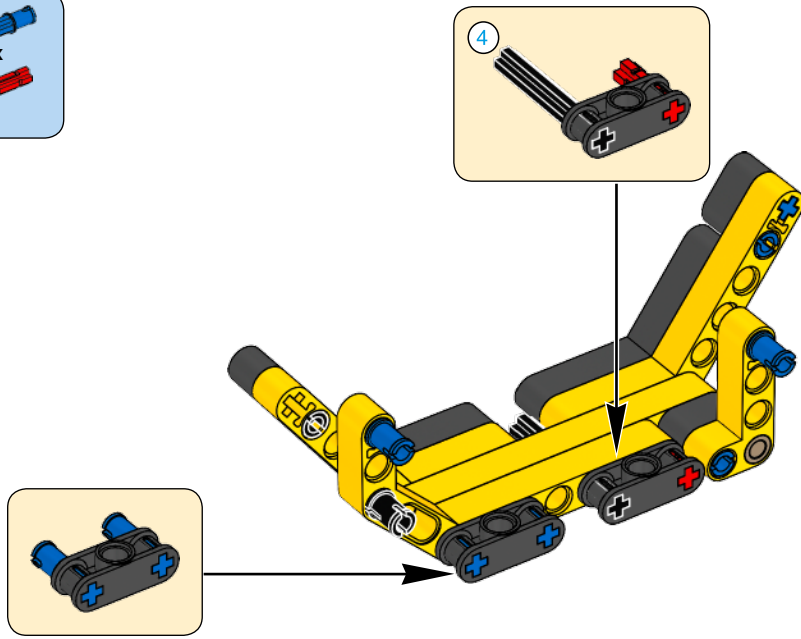

7

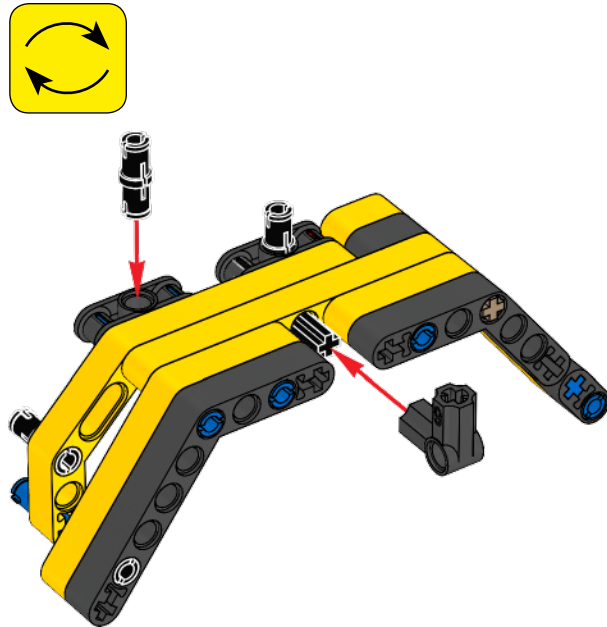

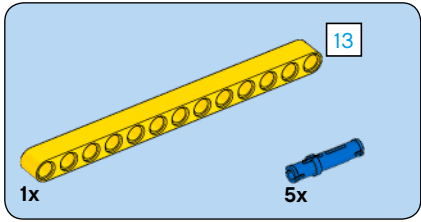
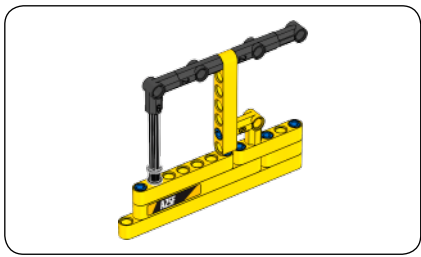

1

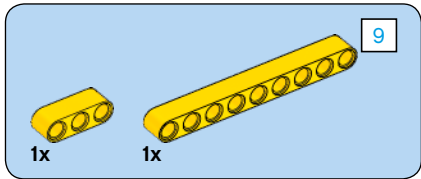
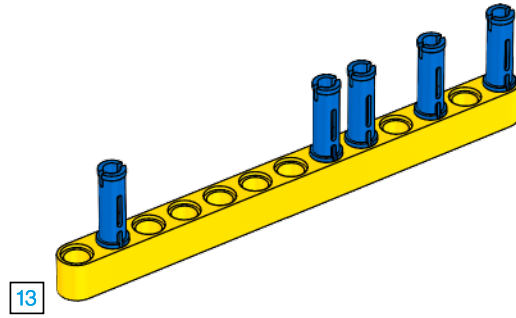

2

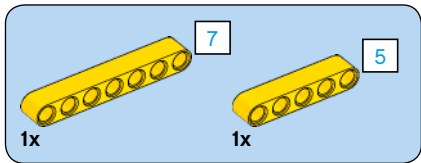
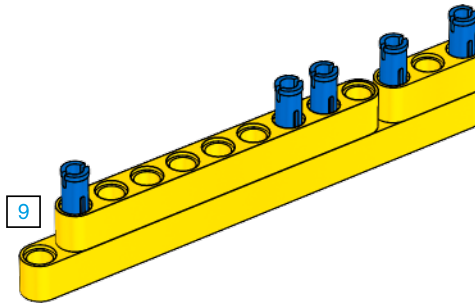

3

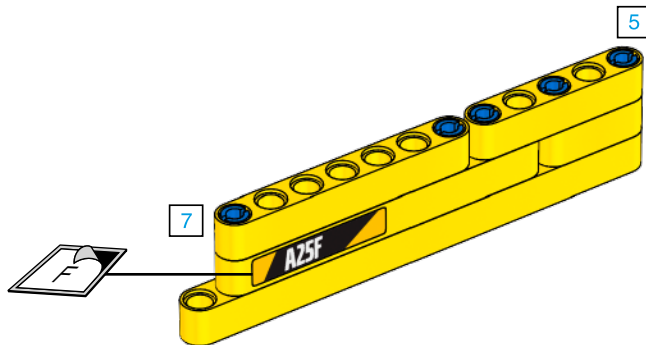

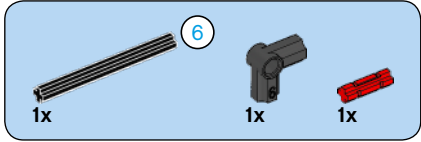
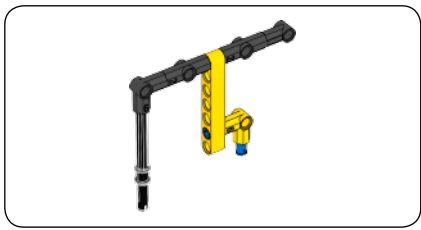

1

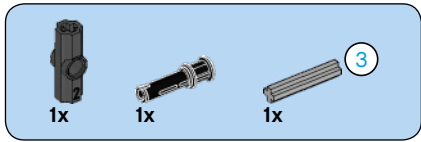

2

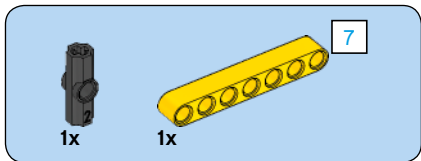

3

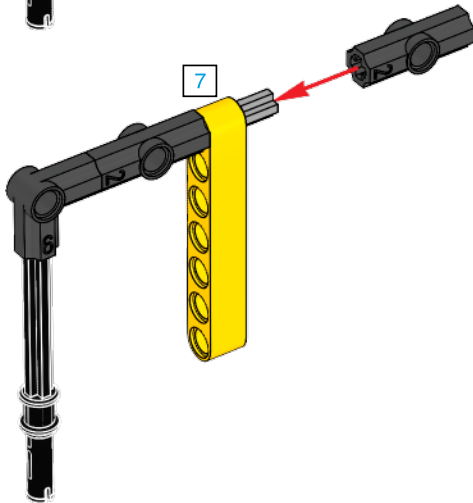
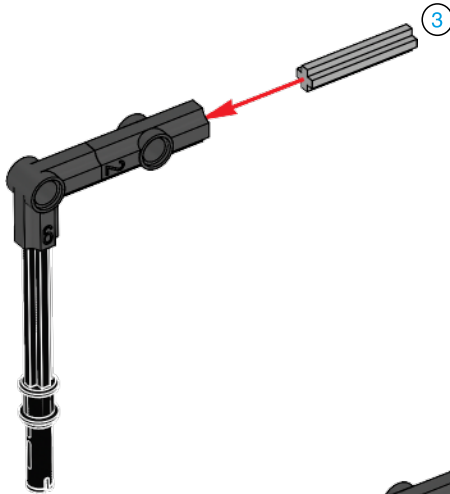
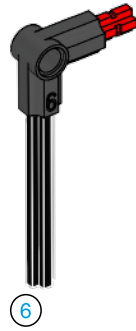

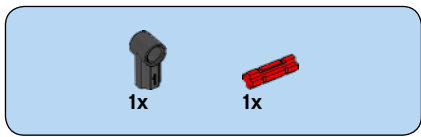

4

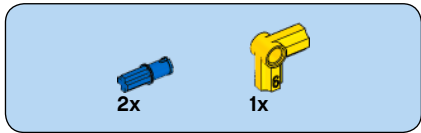
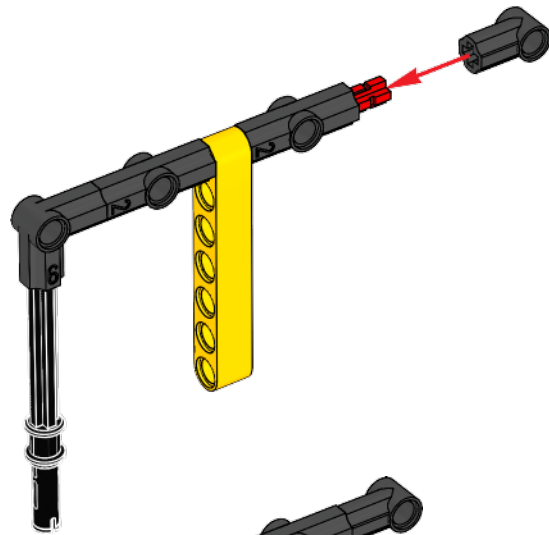

5

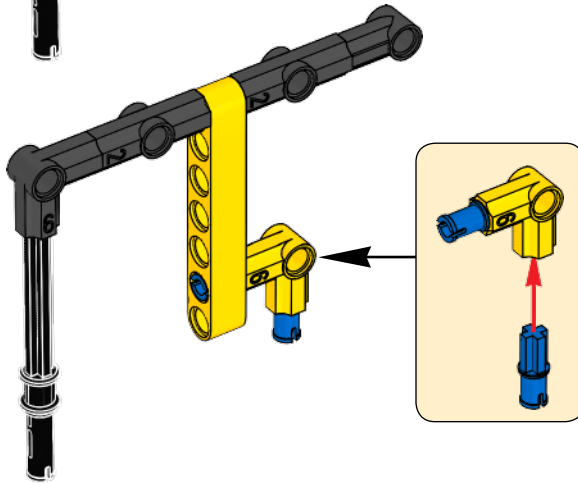

6

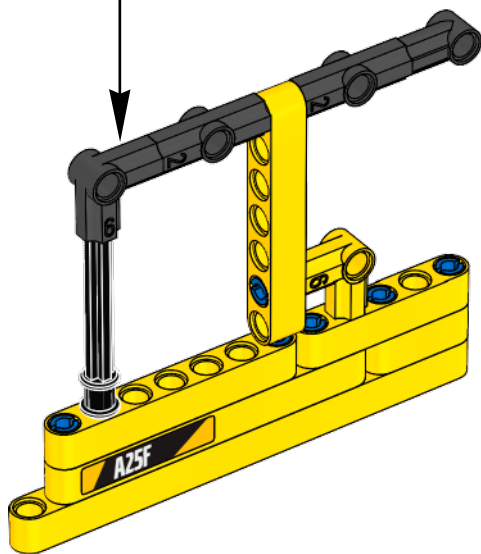

7

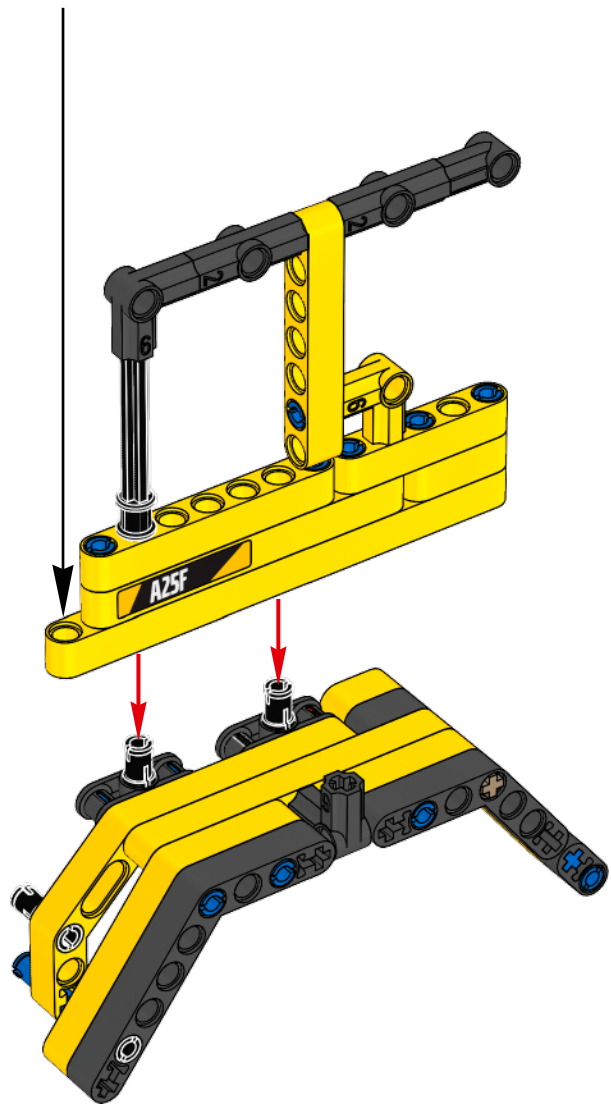

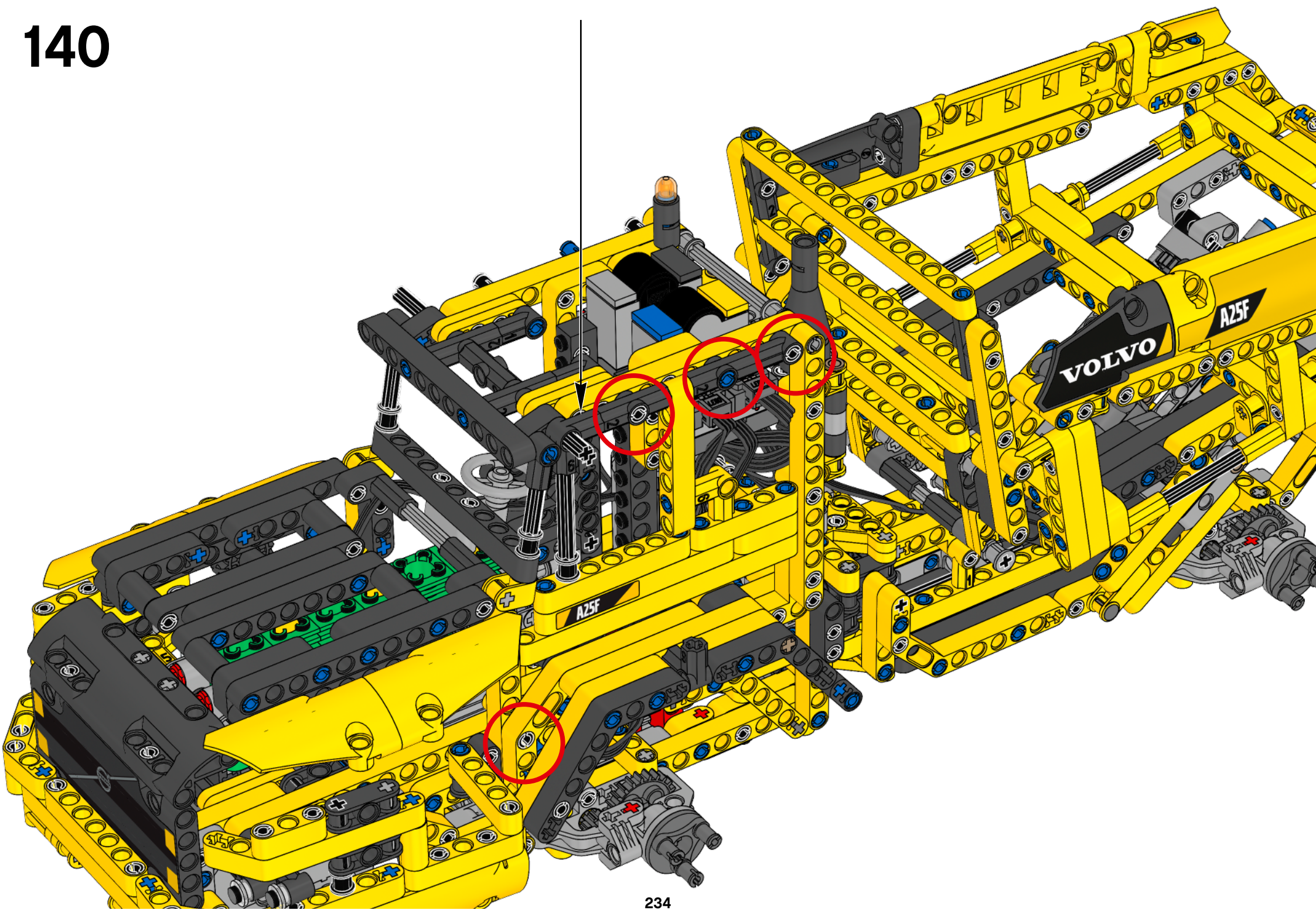

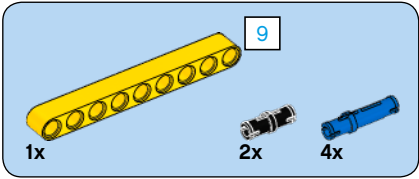
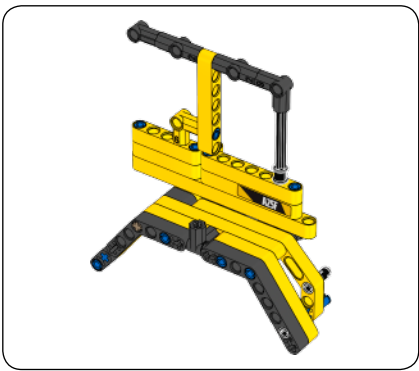

1

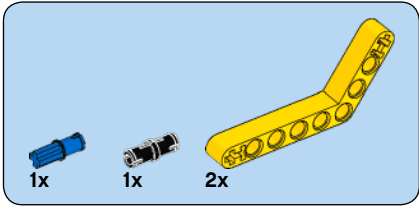
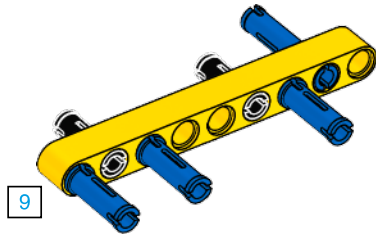

2

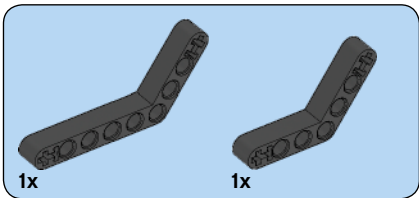
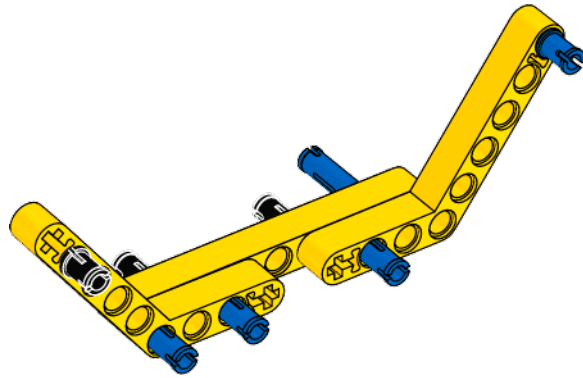

3

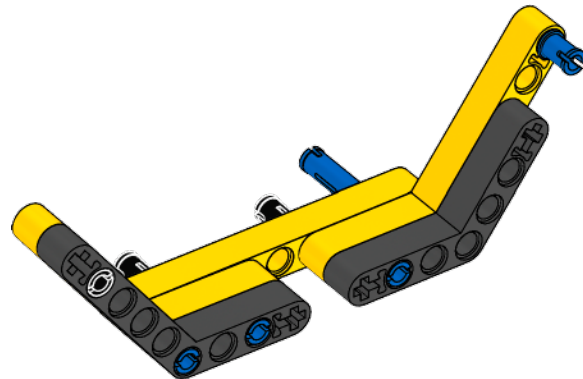

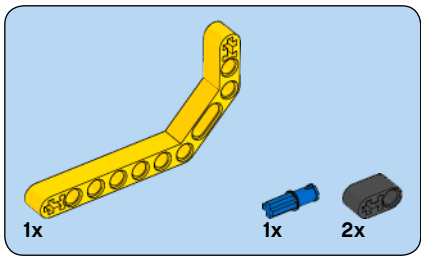

4

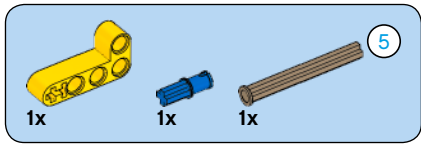
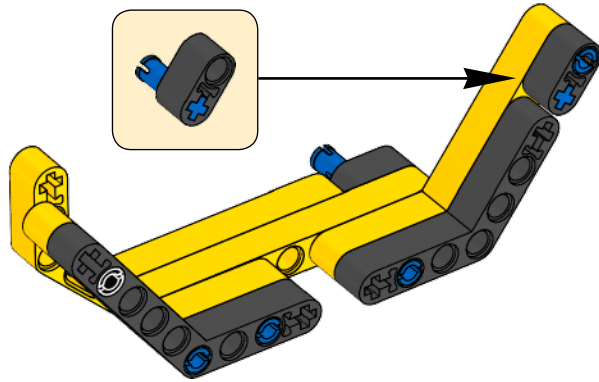

5

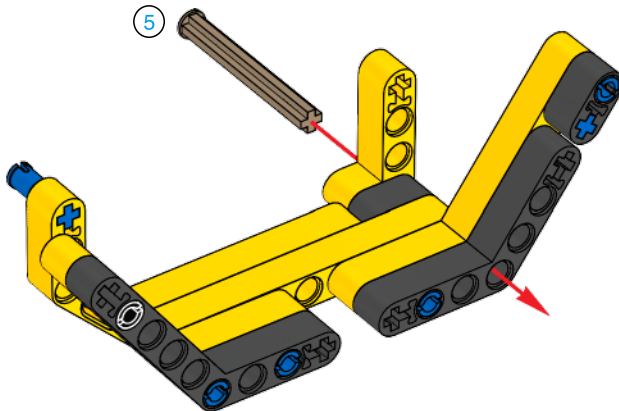

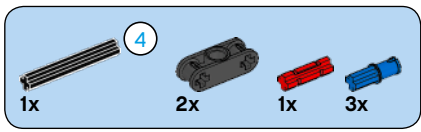

6

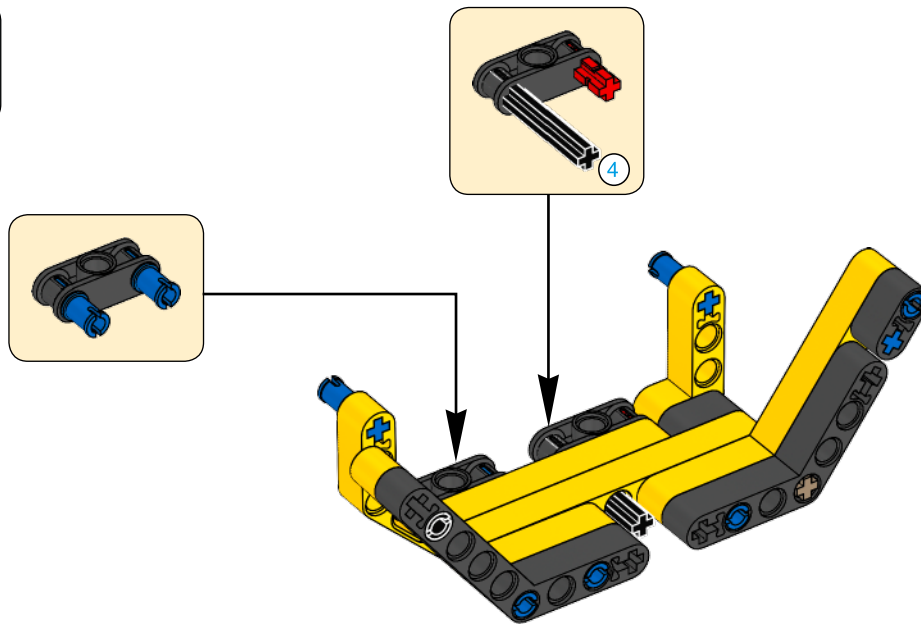

7

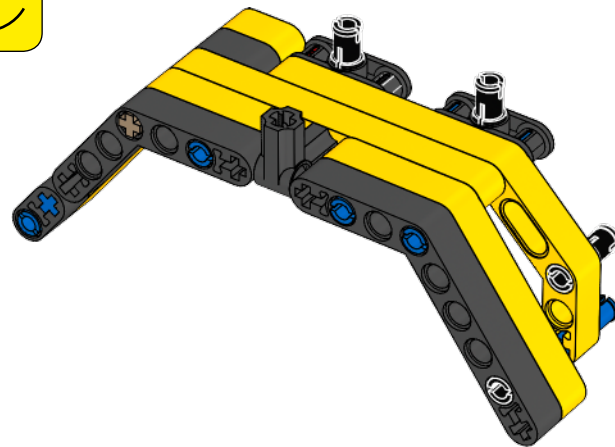
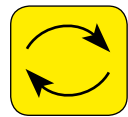

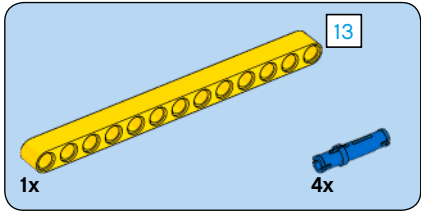
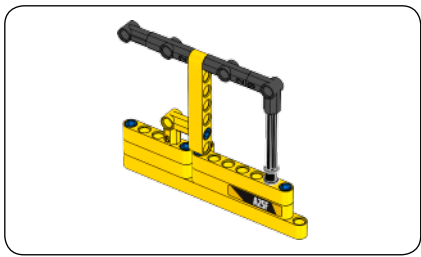

1

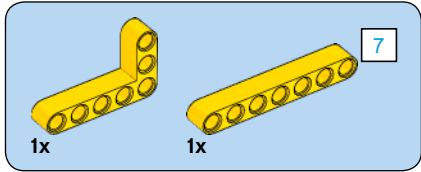

2

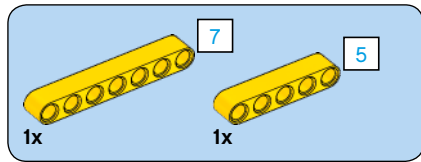

3

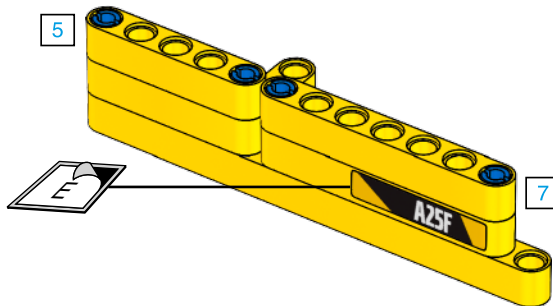
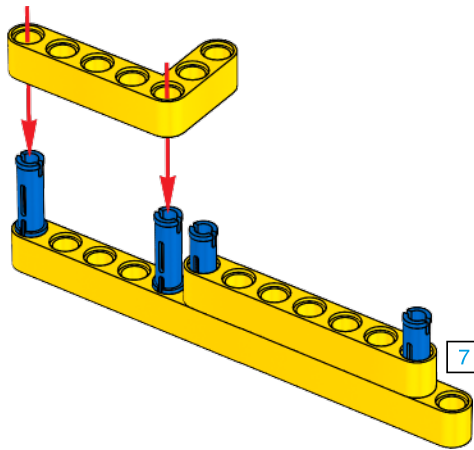
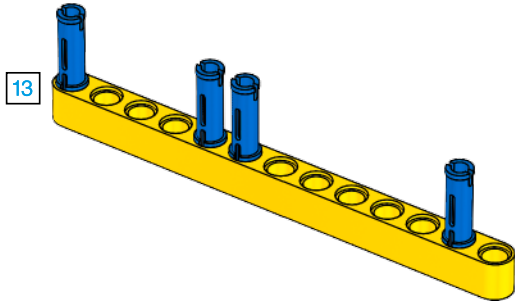

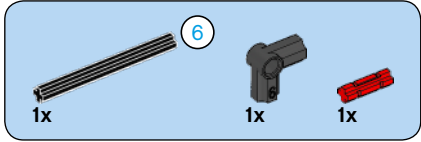
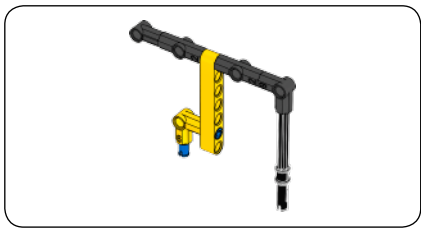

1

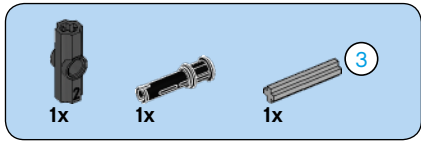
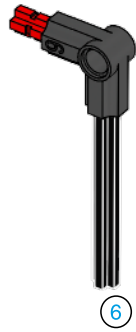

2

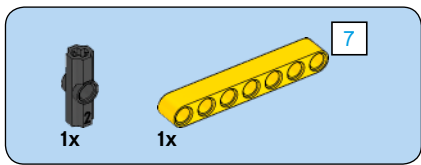
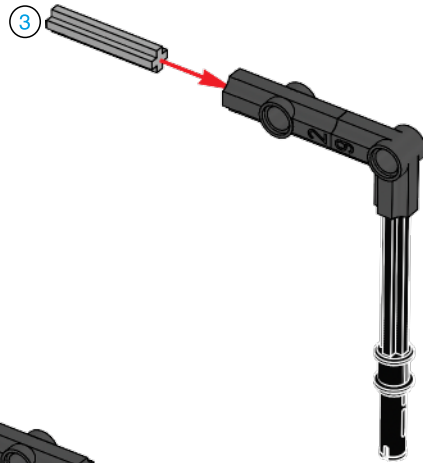

3

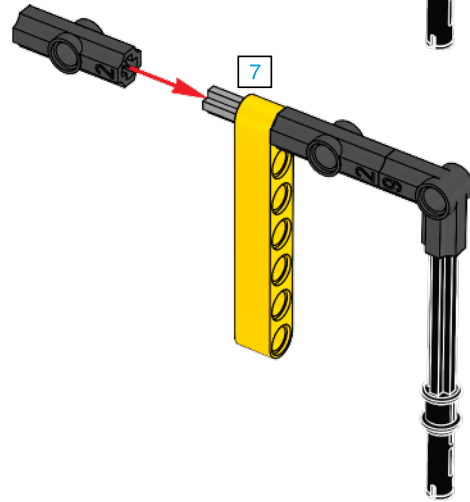

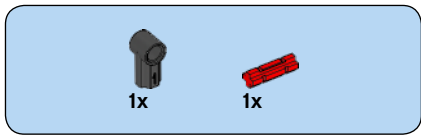

4

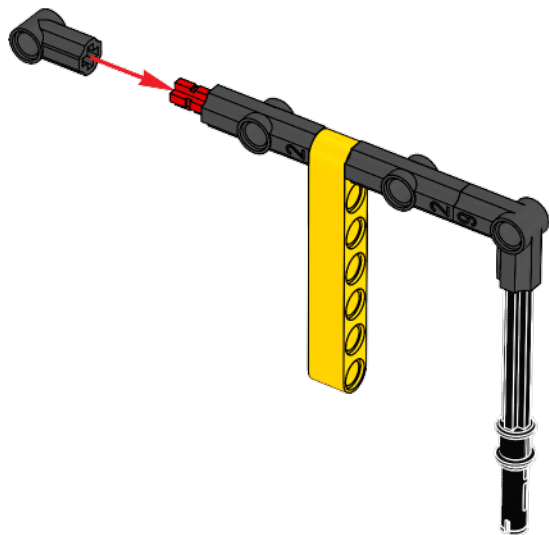

5

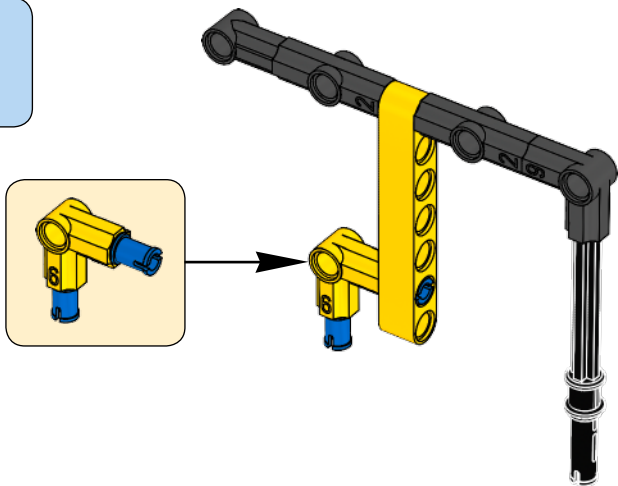

6

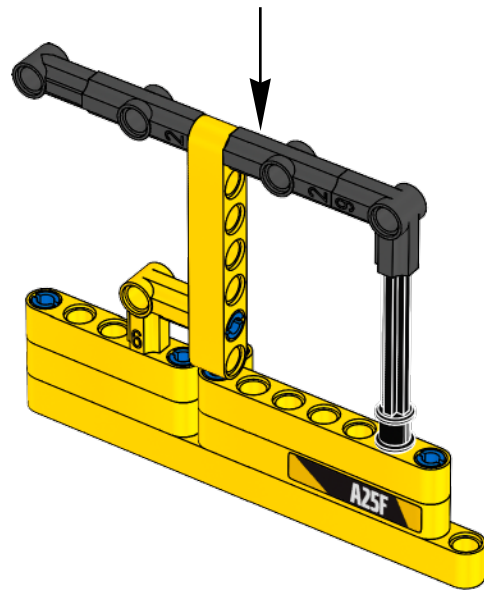

7

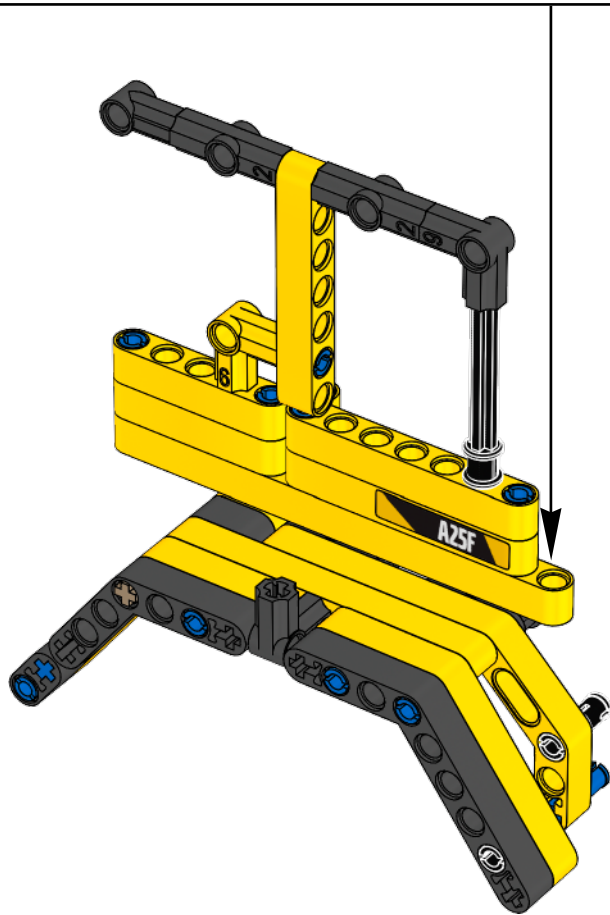

141

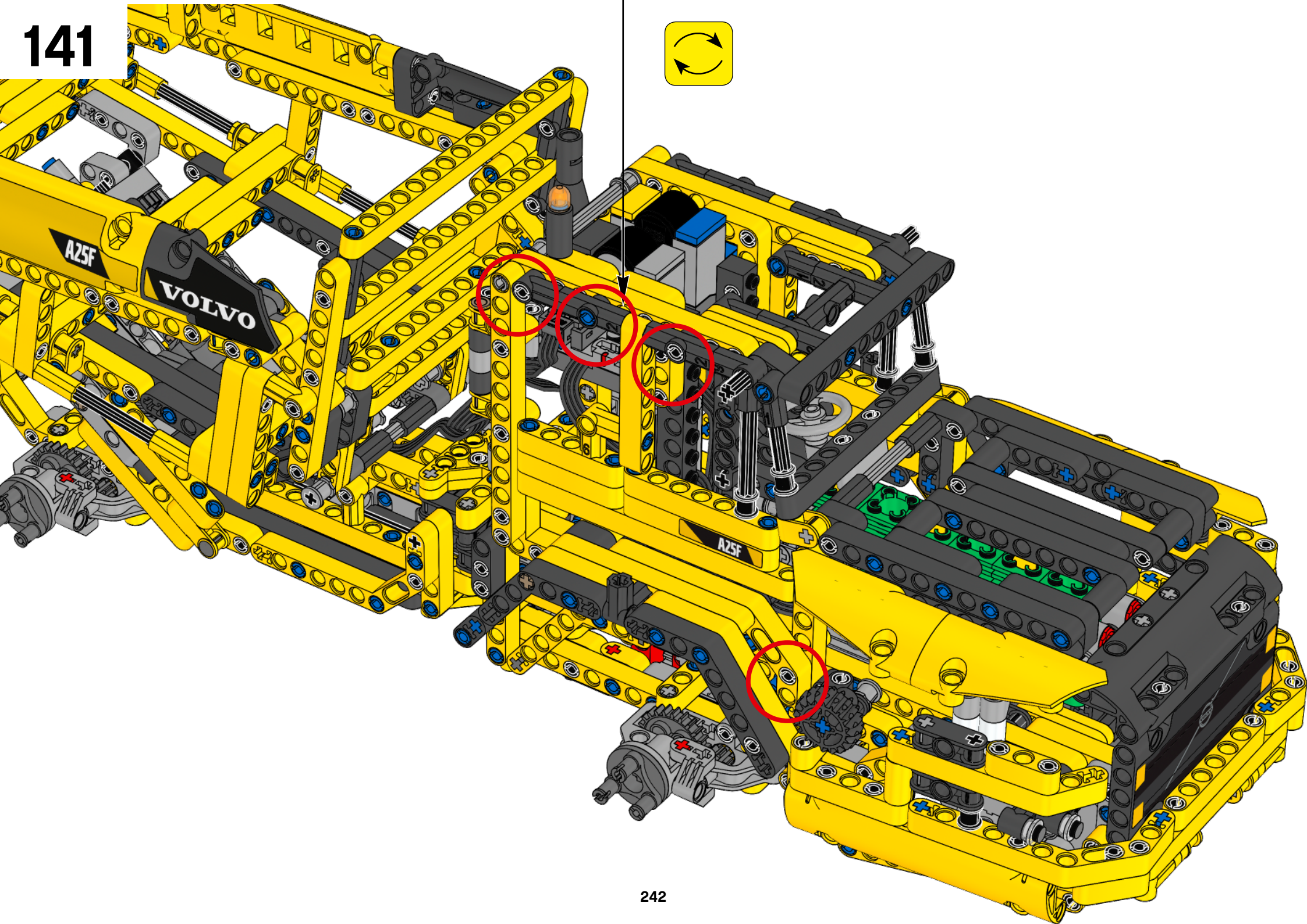
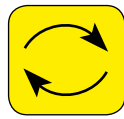

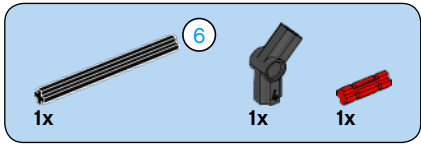
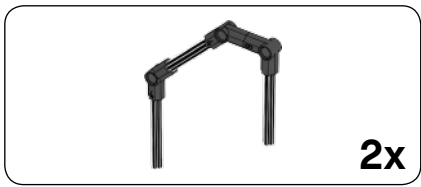

1

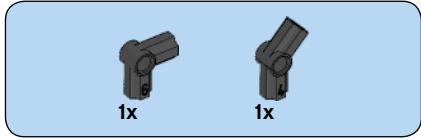
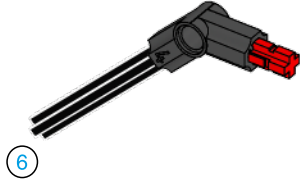

2

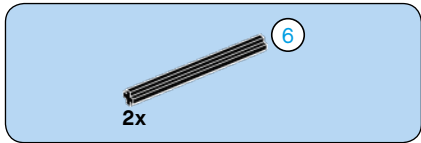
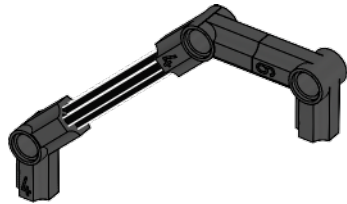

3



2x

142

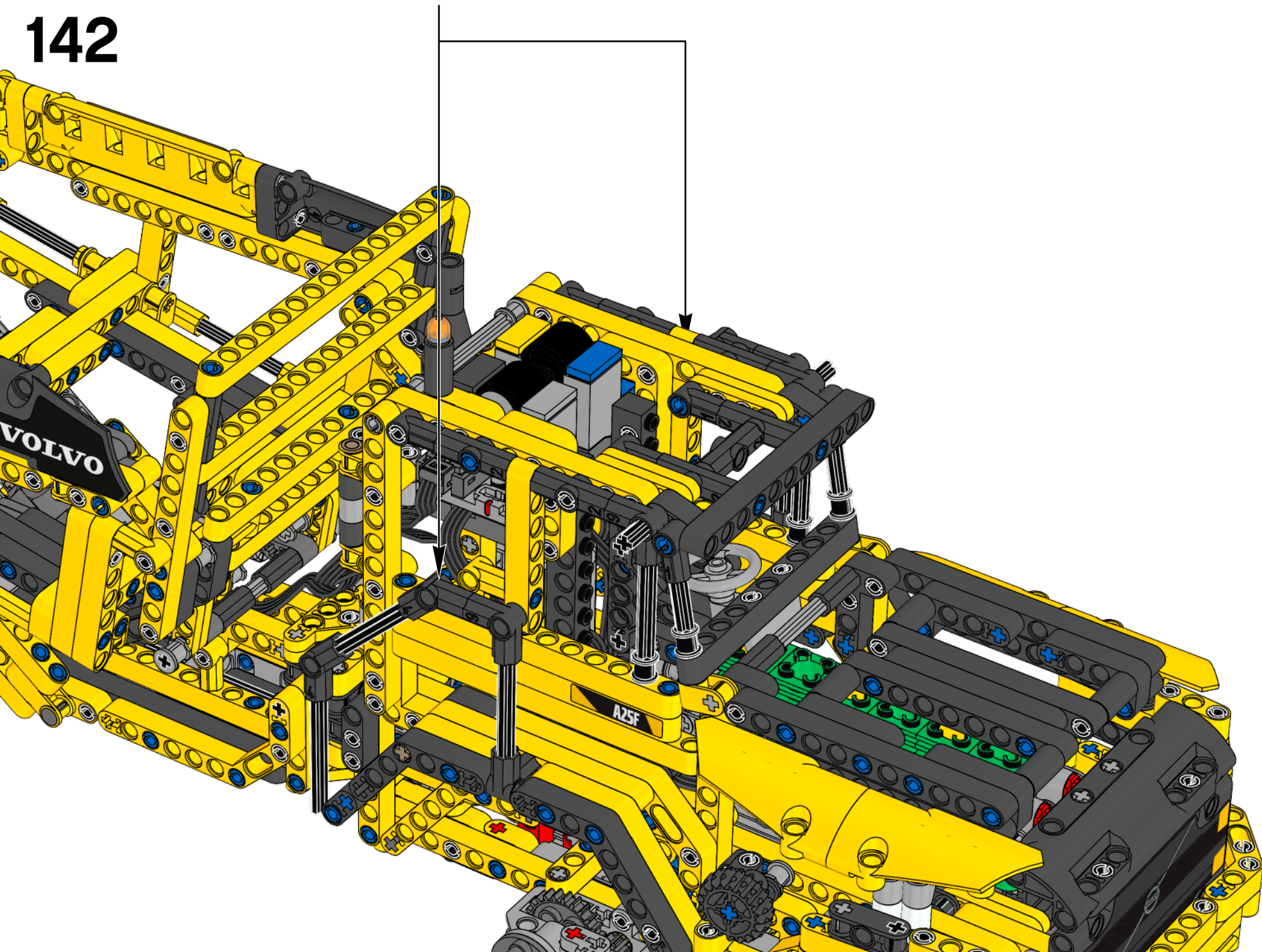

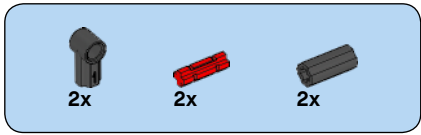

143

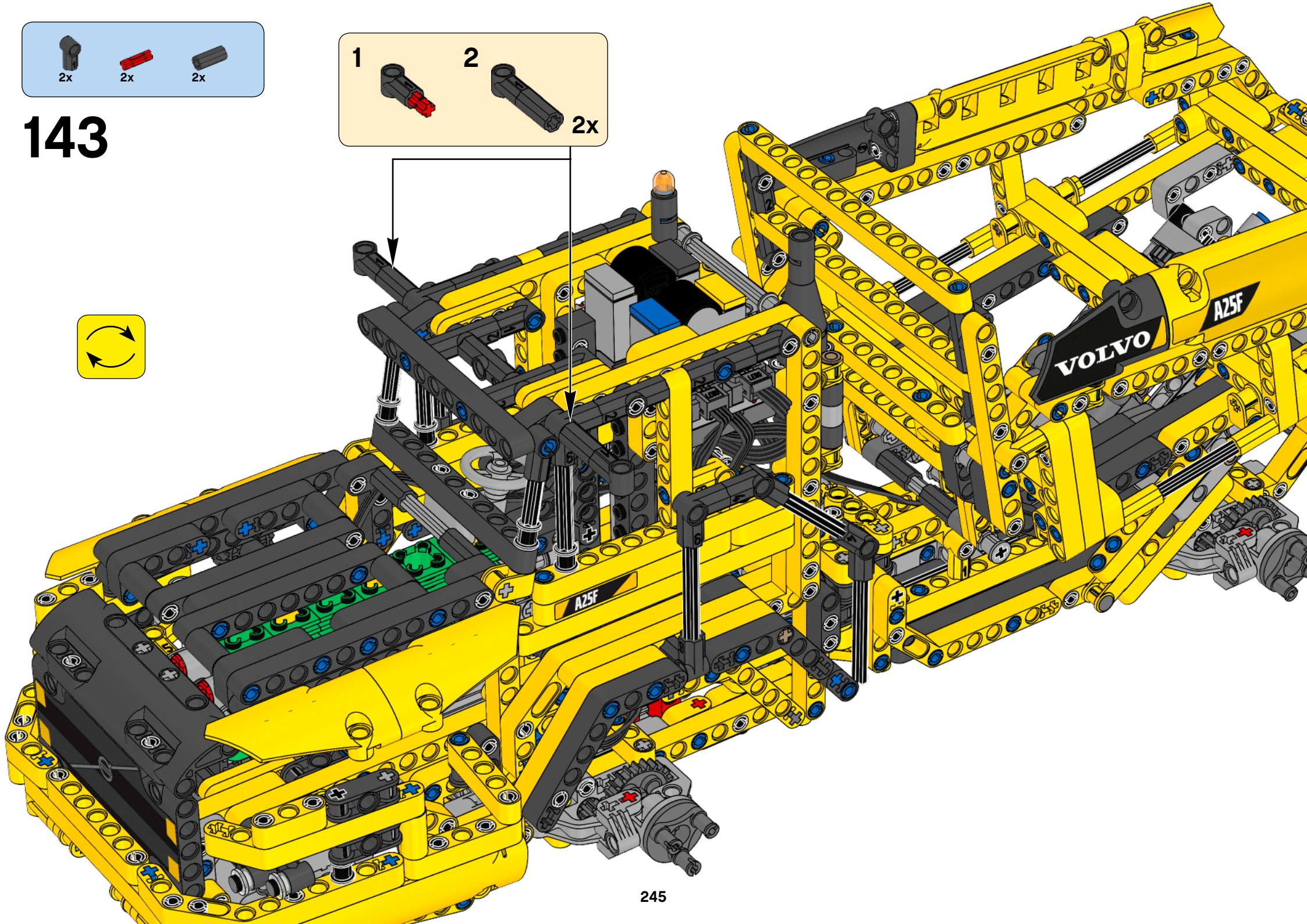
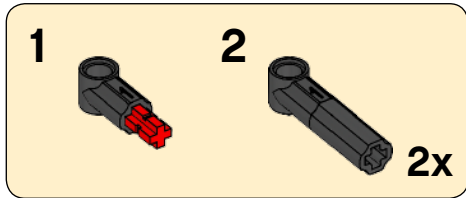

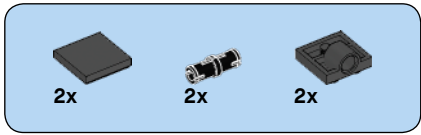

144

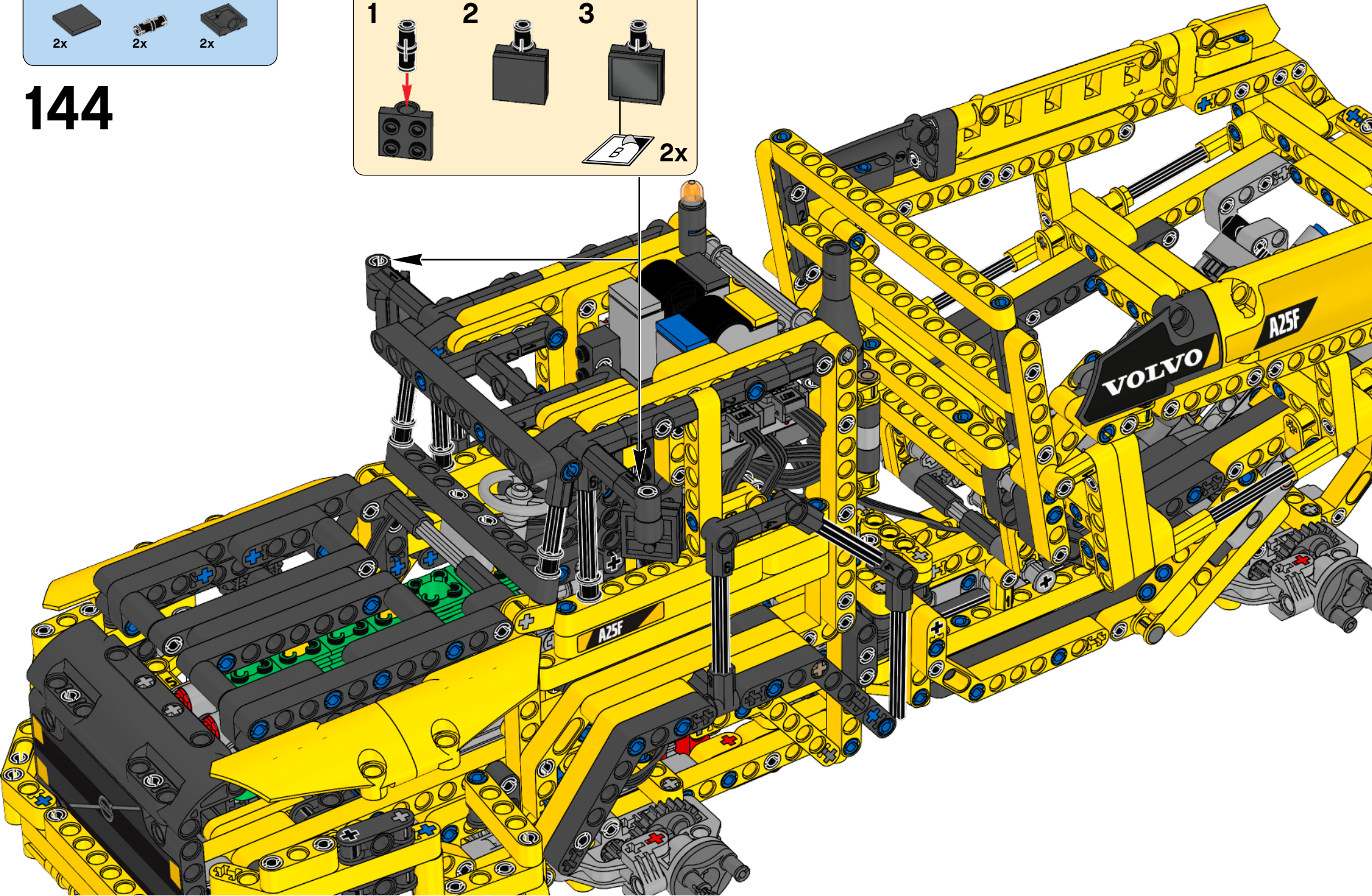
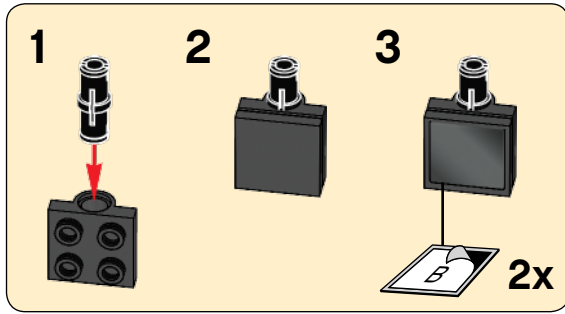

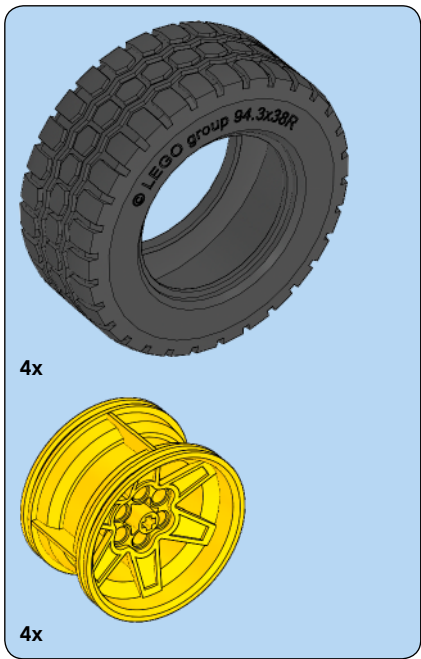

145

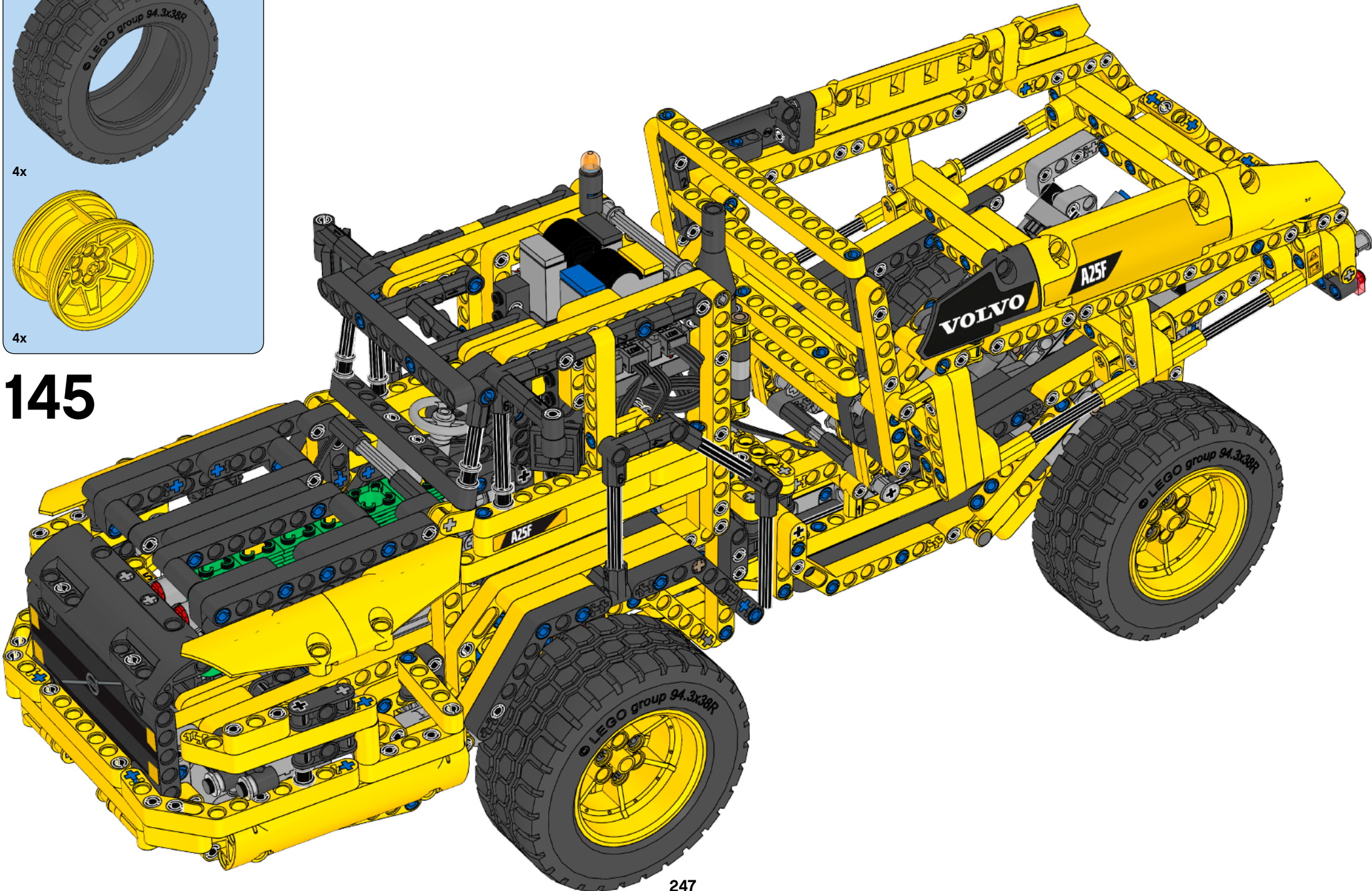

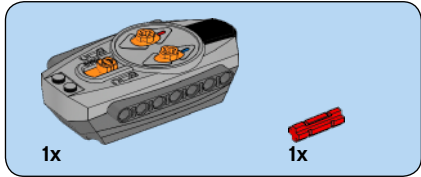
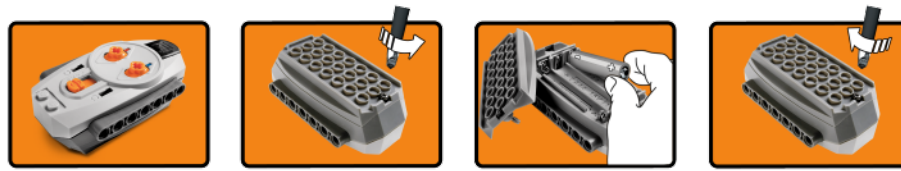
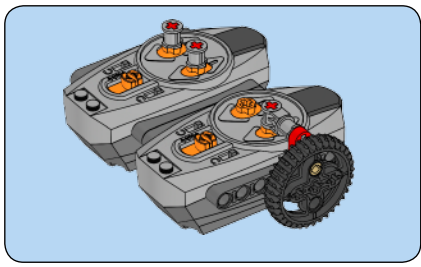

1

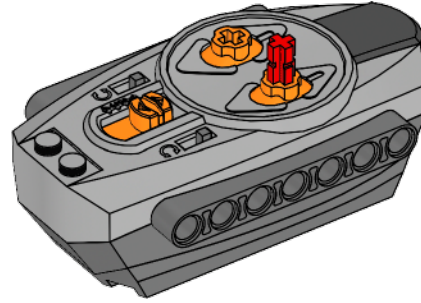

2

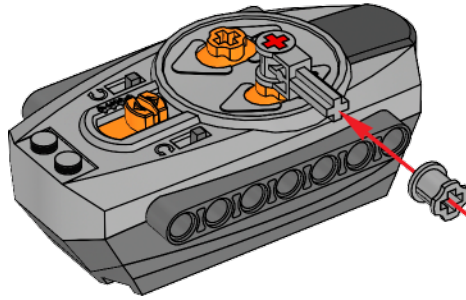

3

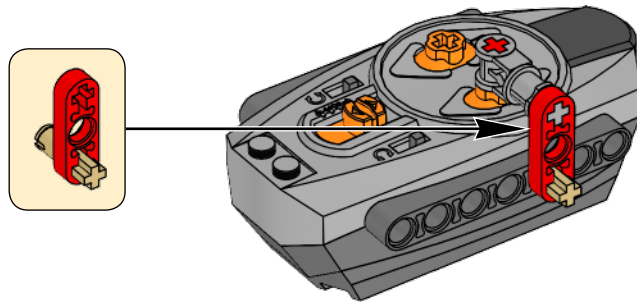

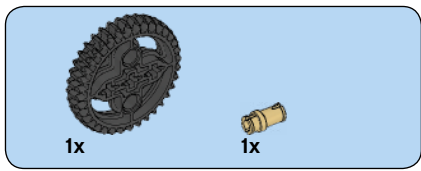

4

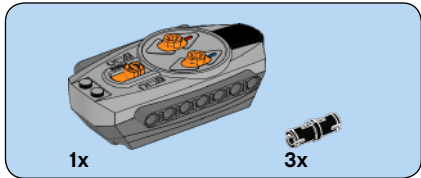
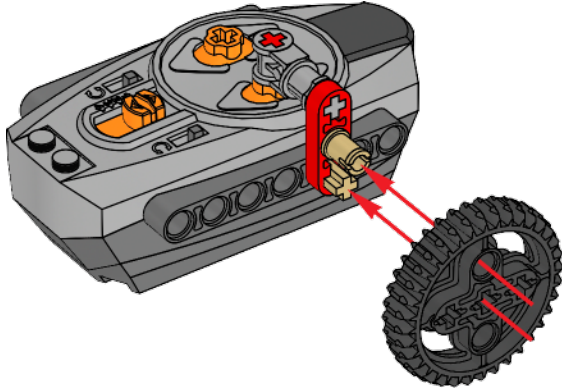

5

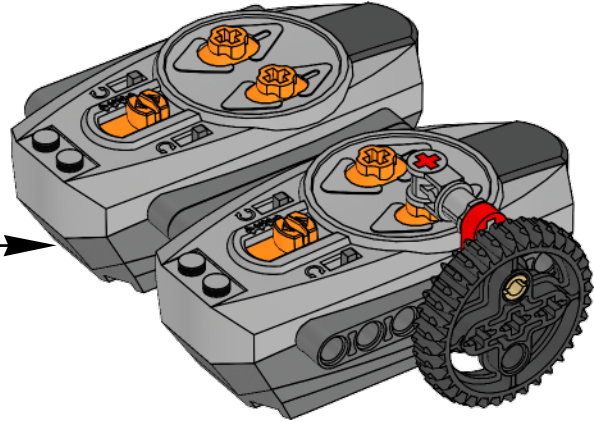
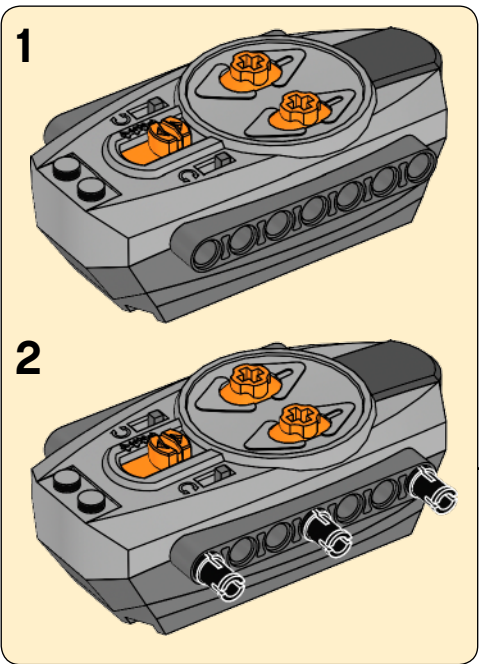

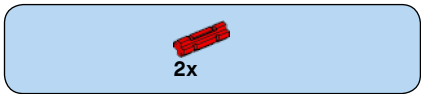

6

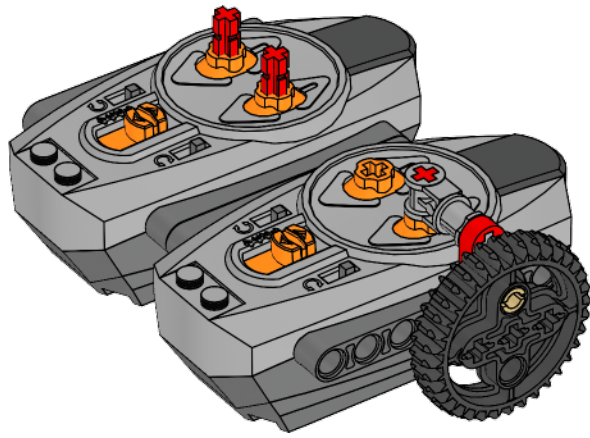

7

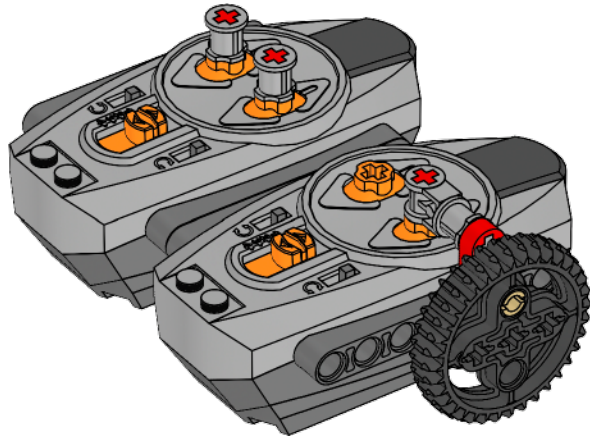

8

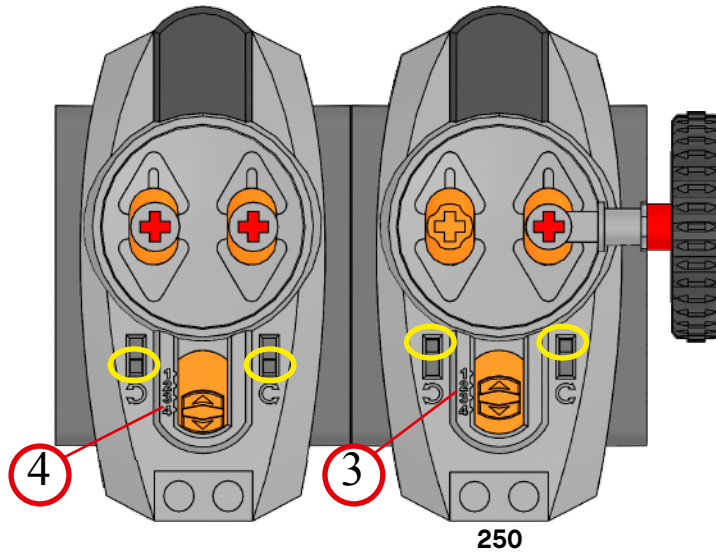

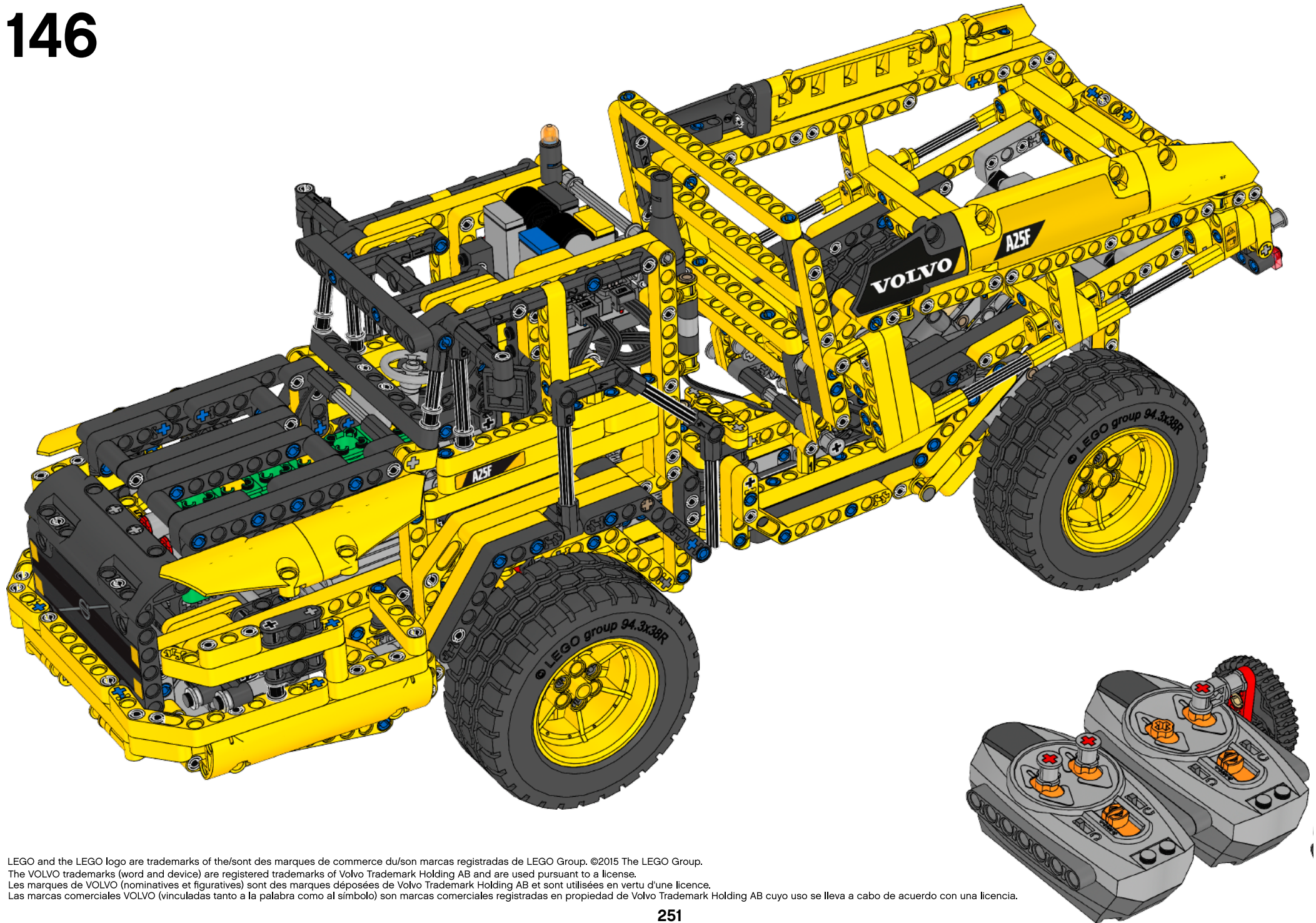

LEGO and the LEGO logo are trademarks of the/son des marques de commerce du/son marcas registradas de LEGO Group. ©2015 The LEGO Group.
 The VOLVO trademarks (word and device) are registered trademarks of Volvo Trademark Holding AB and are used pursuant to a license.
 Les marques de VOLVO (nominatives et figuratives) sont des marques déposées de Volvo Trademark Holding AB et sont utilisées en vertu d'une licence.
 Las marcas comerciales VOLVO (vinculadas tanto a la palabra como al símbolo) son marcas comerciales registradas en propiedad de Volvo Trademark Holding AB cuyo uso se lleva a cabo de acuerdo con una licencia.

