



CITY

7635





1

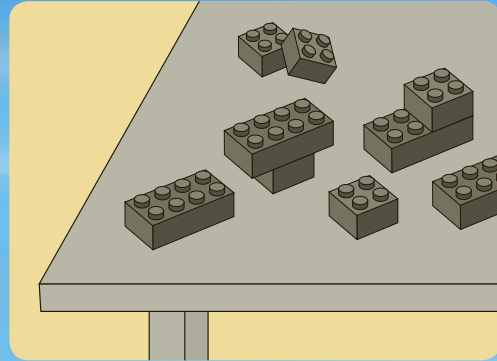
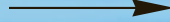
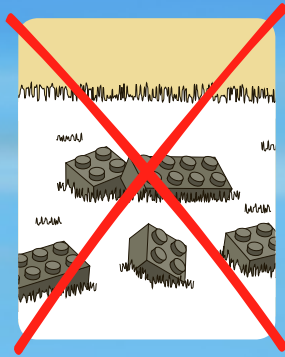

2

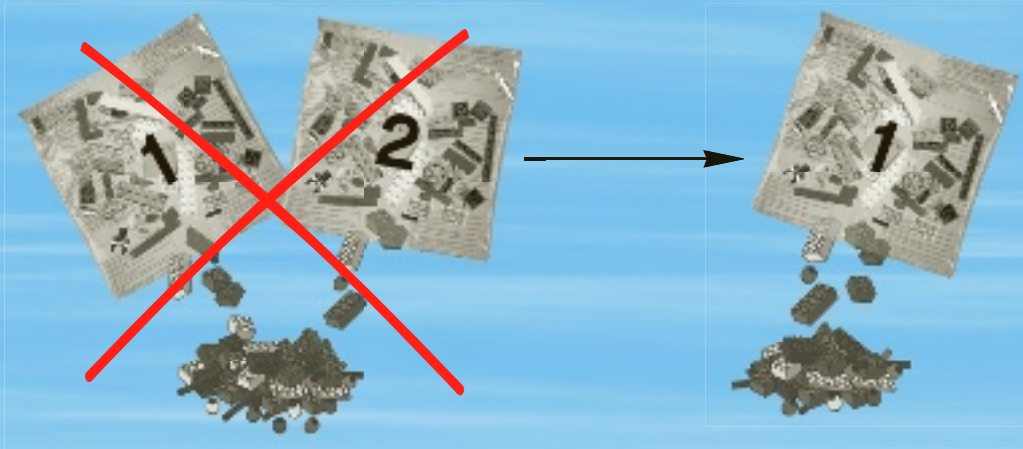



1

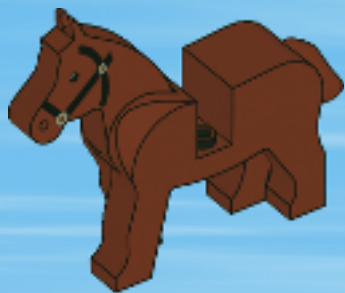

2

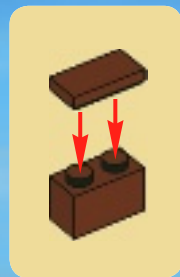

1

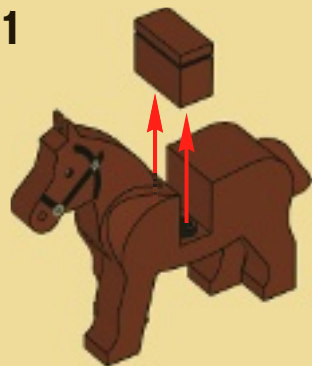

2

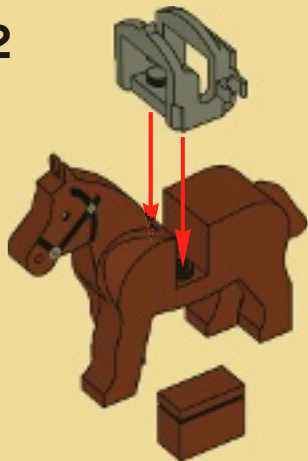



1

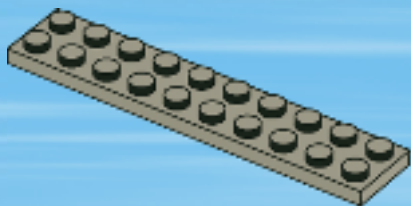

2

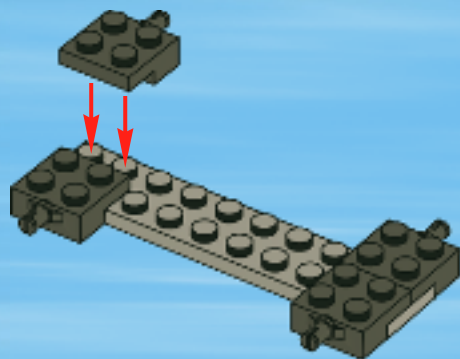

3

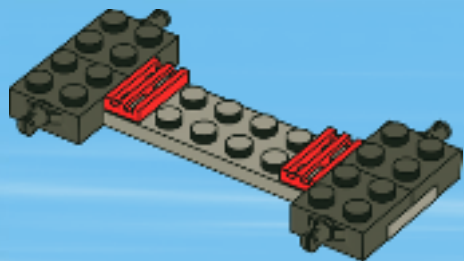

4

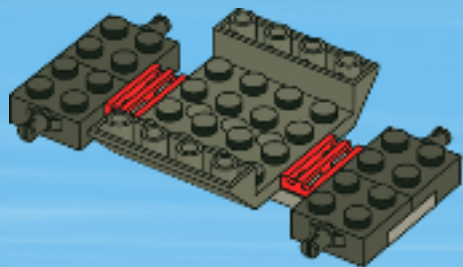

5

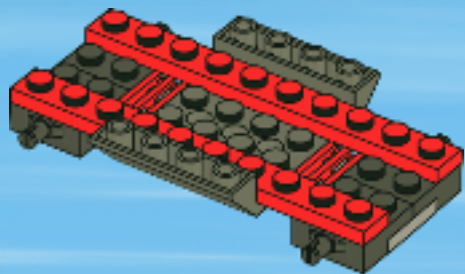

6

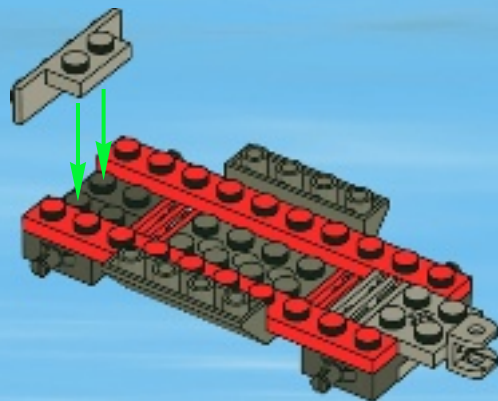

7

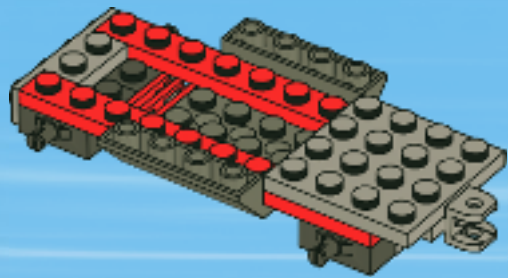

8

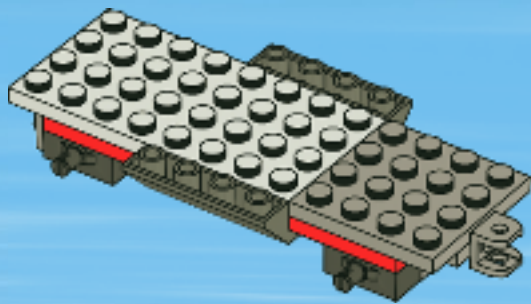

9

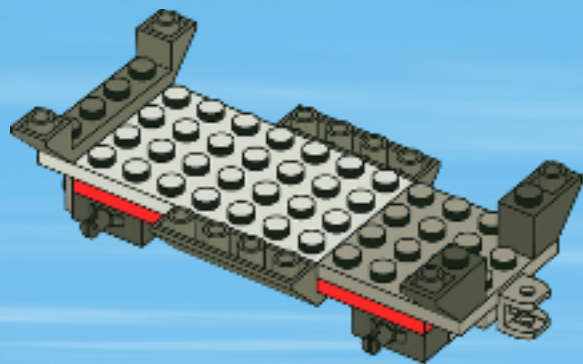

10

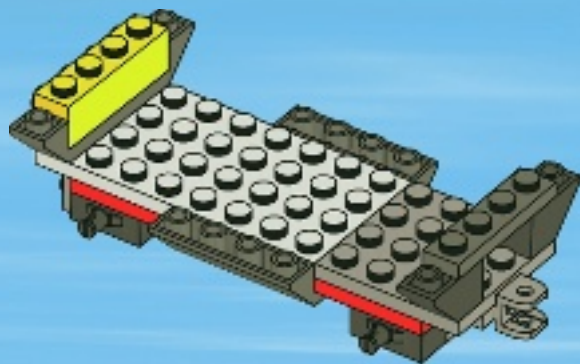

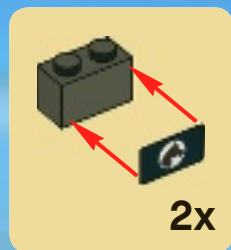

11

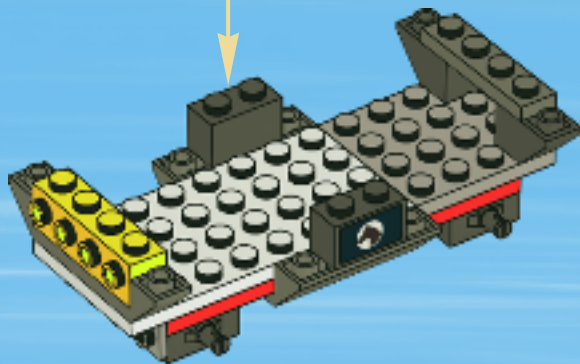

12

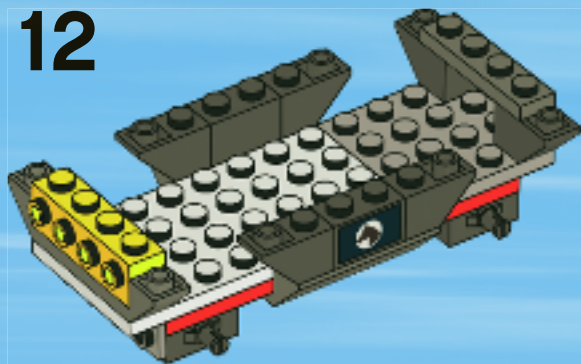

13

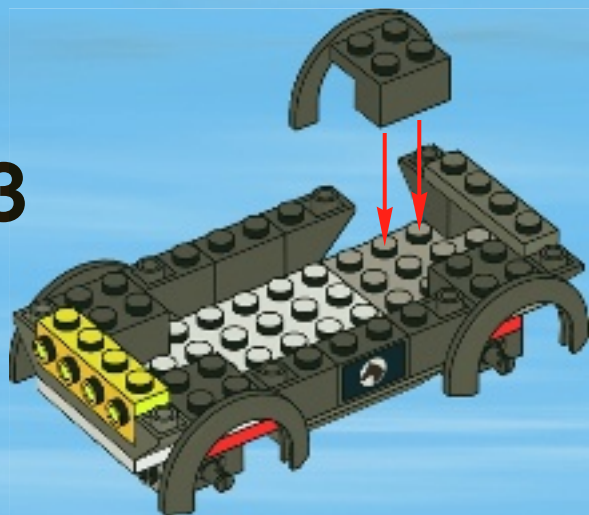

14

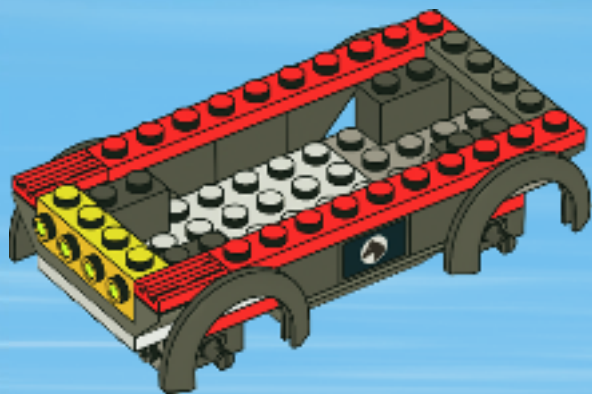

15

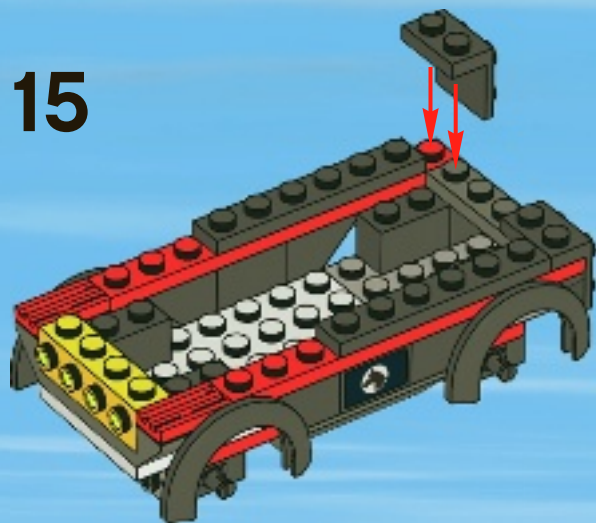

16



17

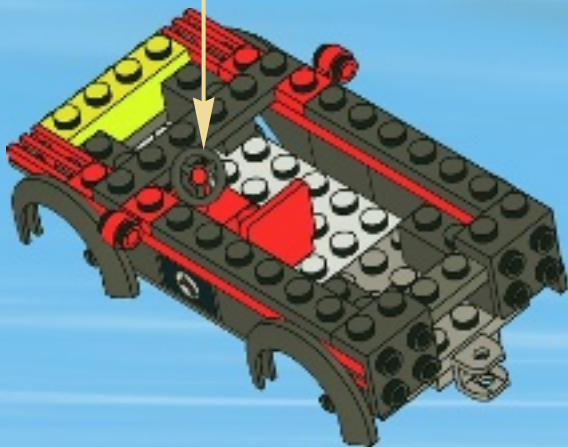
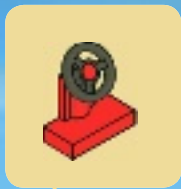

18

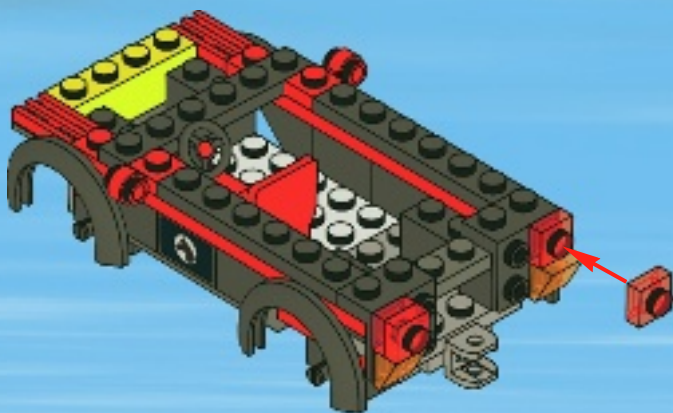

19

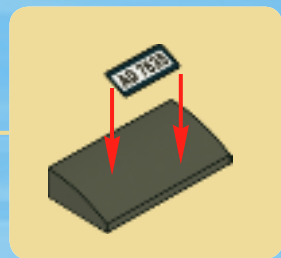
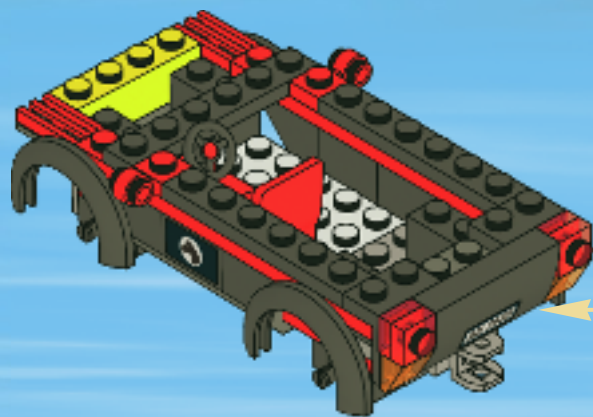

1



2



3

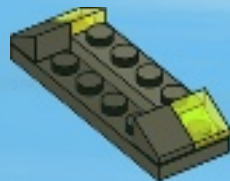

4



20



1

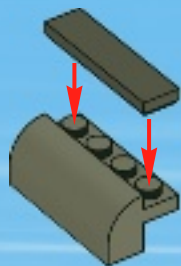

2

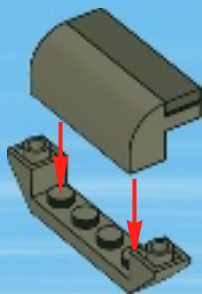

3



21

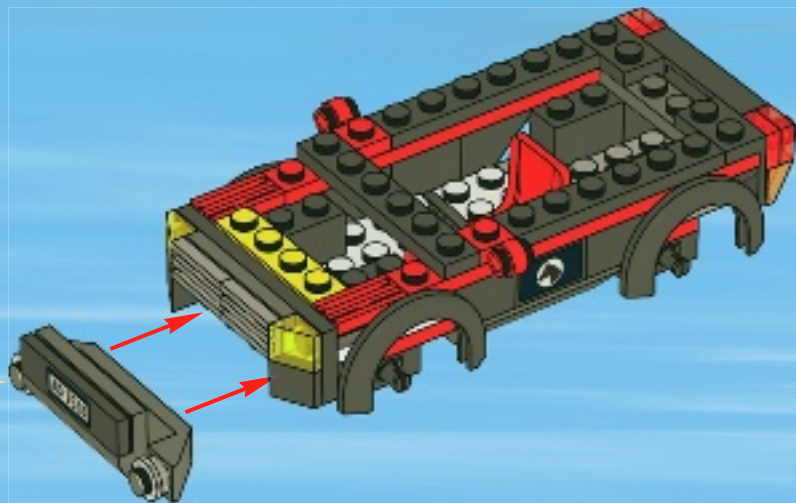

22

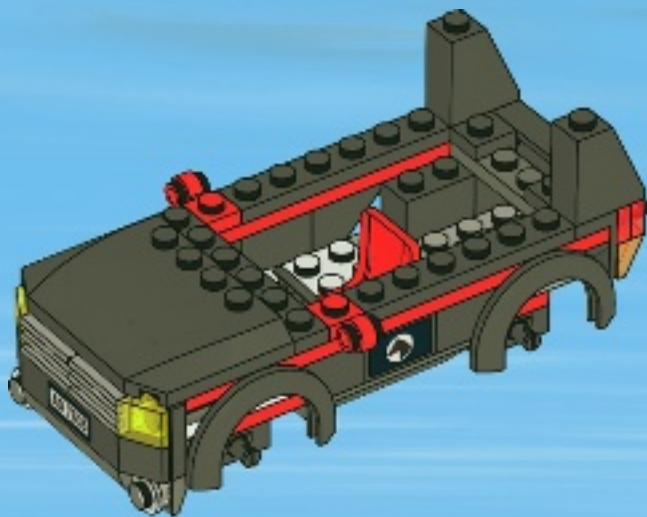

23

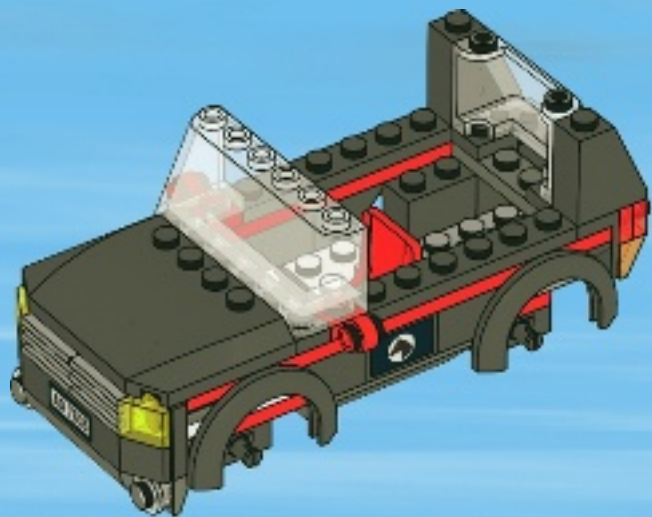

24

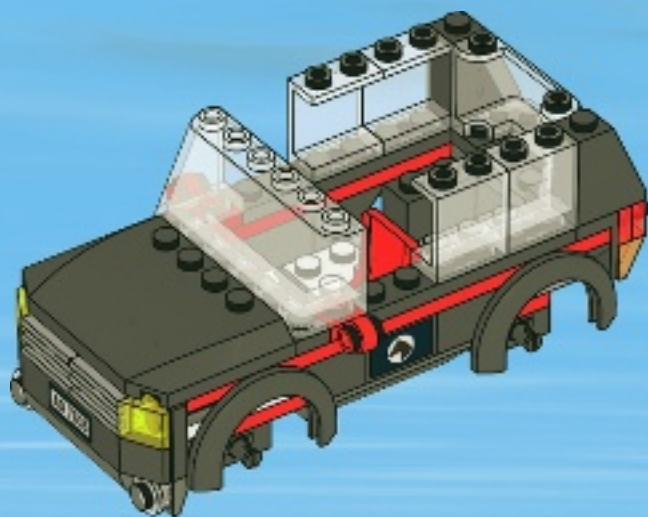

25

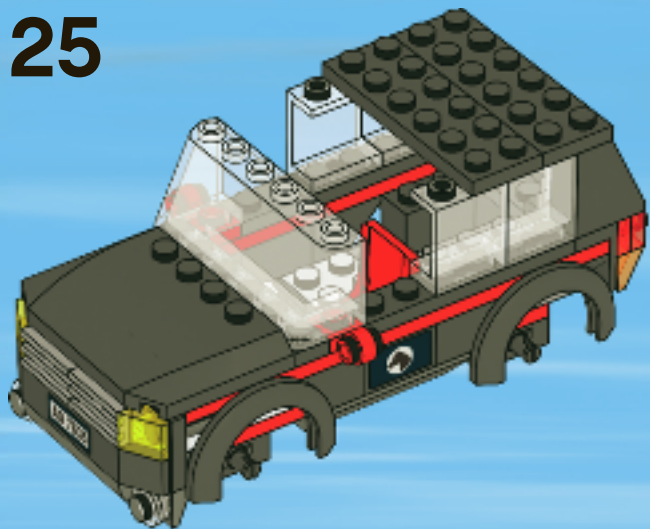

26

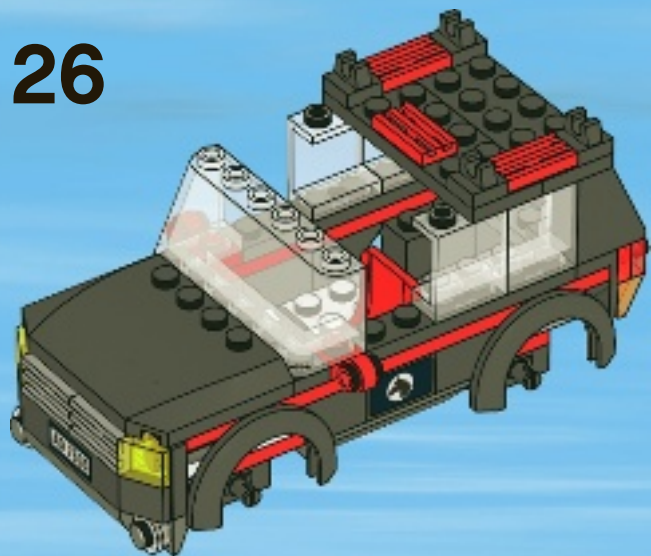

27

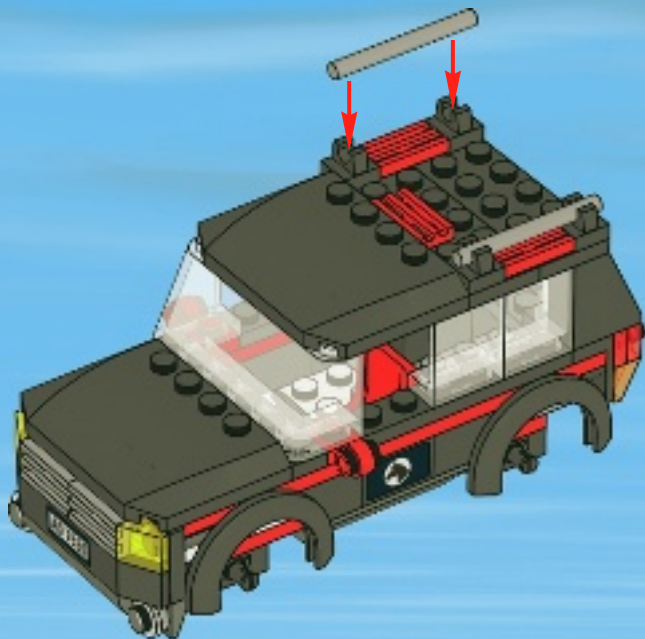

28

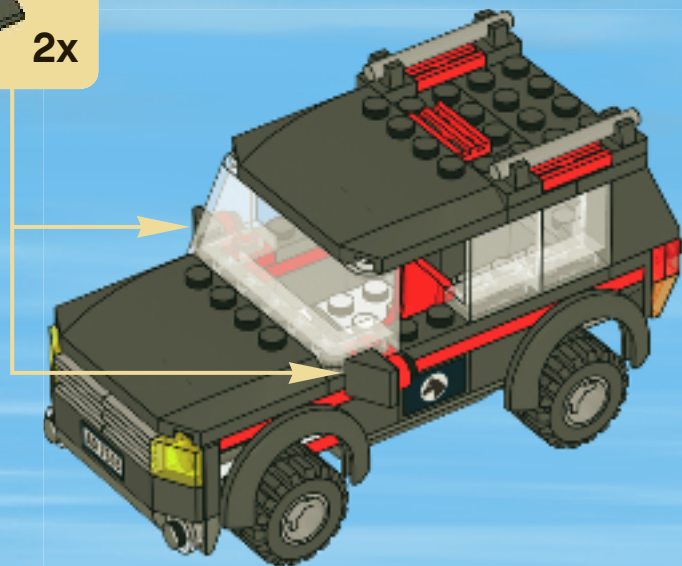



2



1

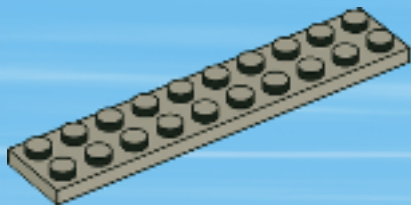

2

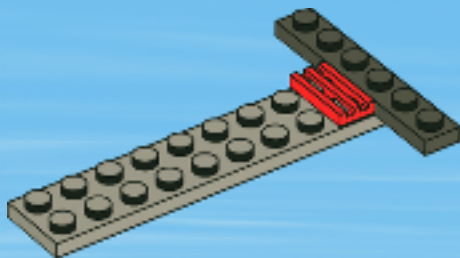

3

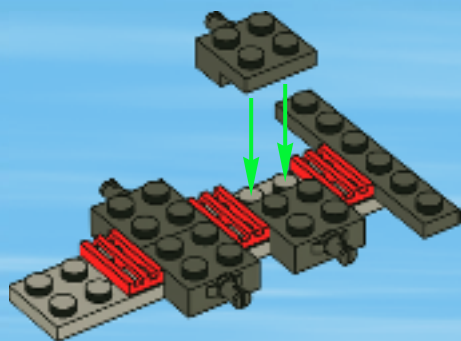

4

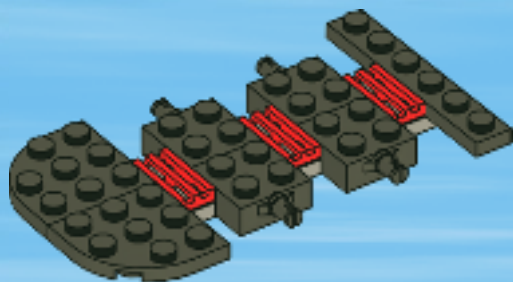

5

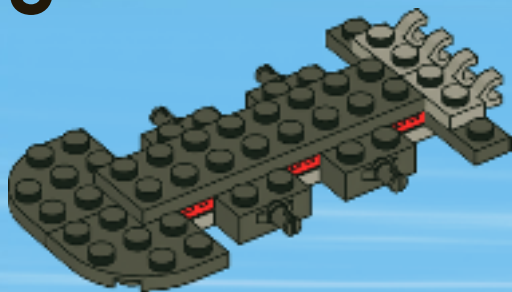

6

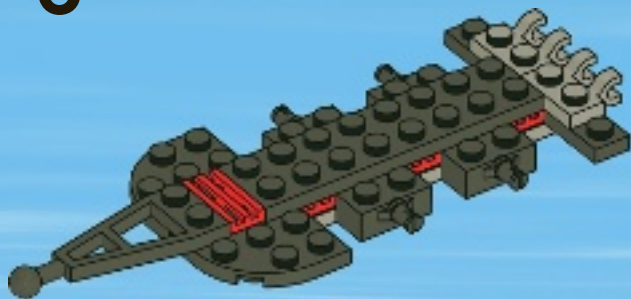

7

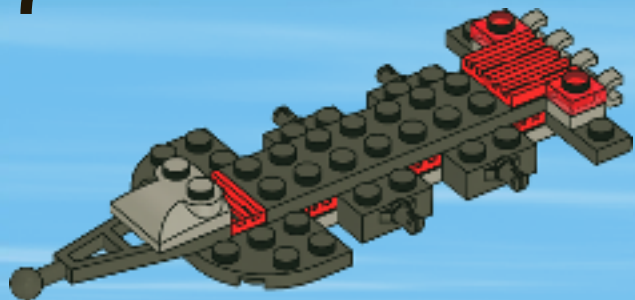

8

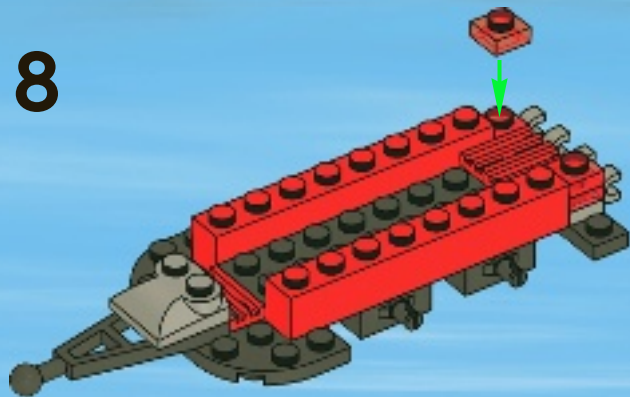

9

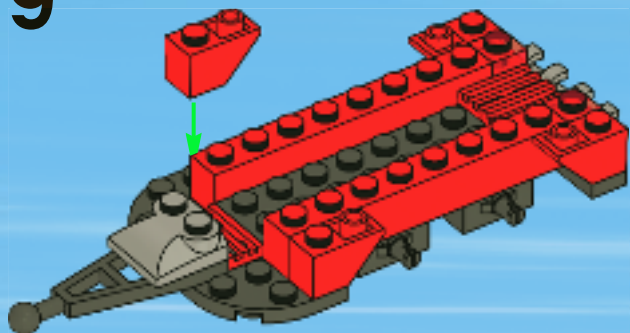

10

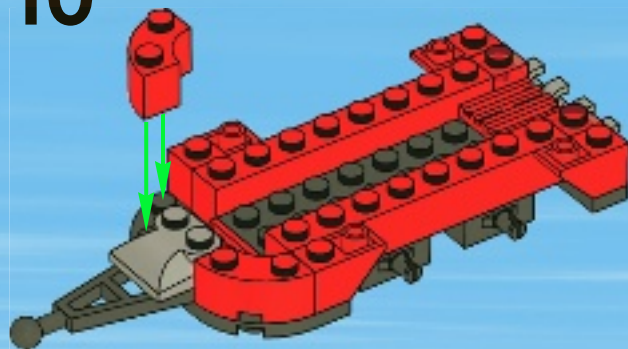

11

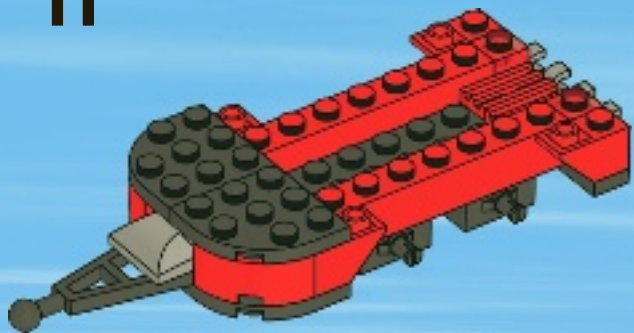

12



13

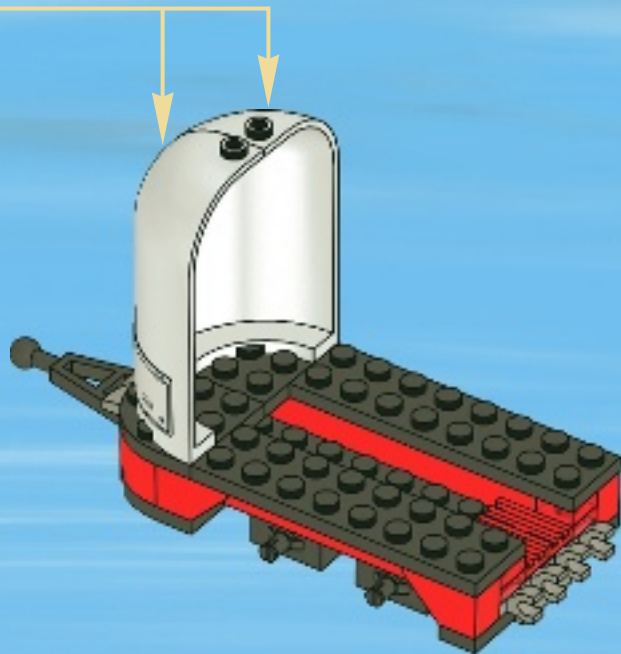
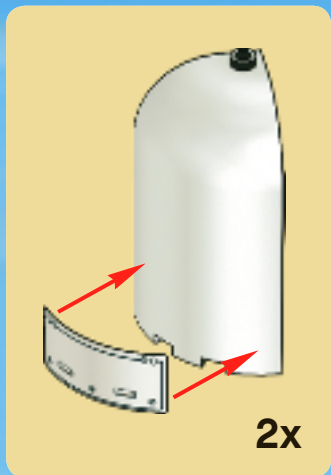

14

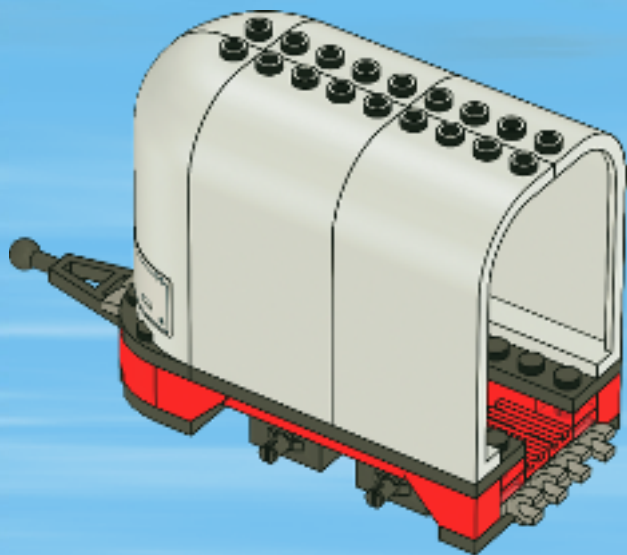

15

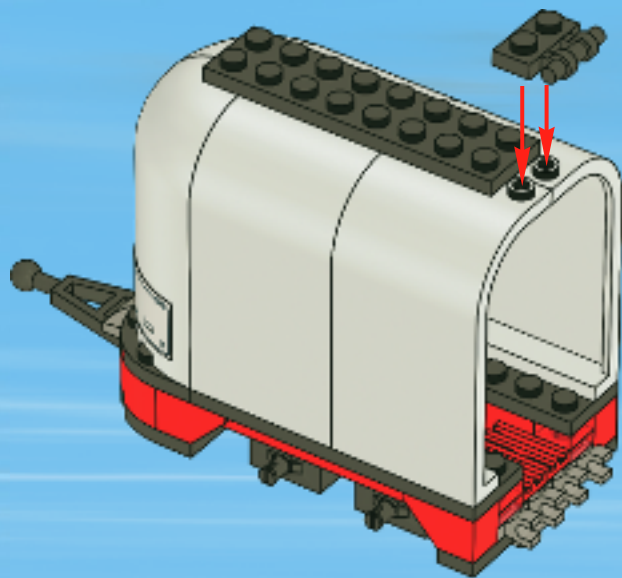

16

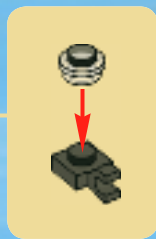
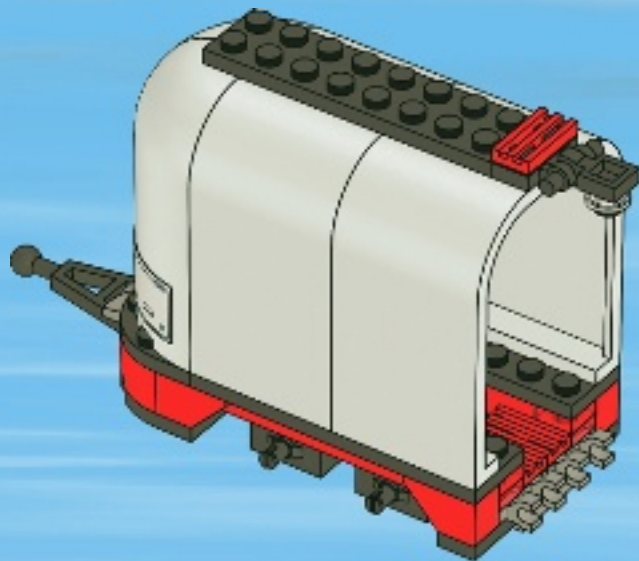

1



2

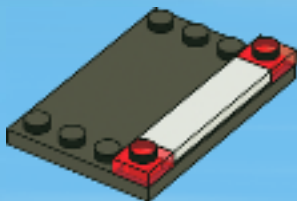

3

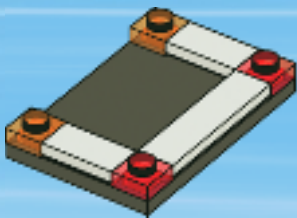

4



5



6

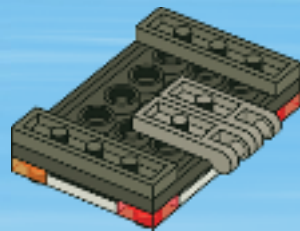

17

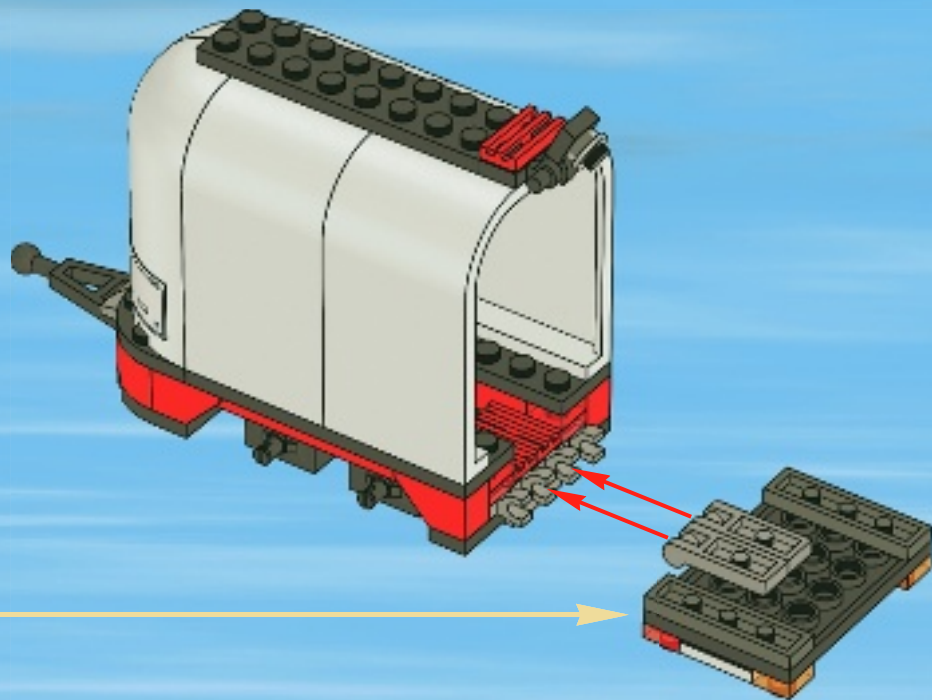

18

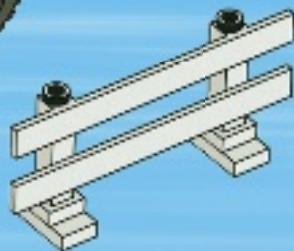
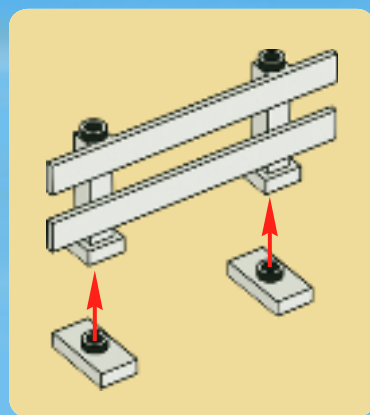





1x
303501



1x
4541808



2x
306901



1x
243101



1x
9327



2x
379401



2x
4541951



4x
4497735



2x
300821

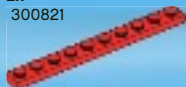

4x
447721



14x
241221



4x
366521



1x
407921



2x
4161412



1x
9552



2x
4170375



10x
3000841



2x
4260942



1x
4164073



1x
4186392



1x
4293369



1x
4275821



1x
4275491



2x
4277932



8x
448826



2x
300426



4x
4260488



1x
243126



1x
4542670



4x
255526



1x
4517925



1x
4140588



1x
4274405



4x
366626



3x
379526



4x
303426



4x
4227392



1x
4100378



2x
4542671



1x
4516431



4x
4504382

6x
366526



2x
4515373



8x
4514560



1x
4282740



2x
4211628



2x
4515173



1x
4494475



3x
4211350



1x
4530469



2x
4515369



8x
4211764



2x
4211462



1x
4243797



1x
4210968



1x
4267282



1x
4212508



2x
4294180



4x
4211001



3x
3005740



4x
4113028



1x
382340



1x
4502193



2x
4542673



2x
4244369



1x
4211149



1x
4211151



1x
4506843



1x
4107623



1x
4529755



Customer Service

Kundenservice

Service Consommateurs

Servicio Al Consumidor

www.lego.com/service or dial



: 00800 5346 5555

: 1-800-422-5346



CITY



7630



7631



7632



7633

LEGO

CITY



7634



7635



7636



7637



CITY



46

7279



7285



7286



7287



7288



7498



www.LEGOclub.com



LEGO Club Email



LEGO Club Magazine

LEGO club

FREE! GRATIS! GRATUIT!

SIGN UP ONLINE!

www.LEGOclub.com



00800 5346 5555*



1-866-534-6258 • 1-877-518-5346

US & Canada only

One-time enrollment

- * Freephone. Mobile charges may apply.
- * Numéro sans frais. Des frais peuvent s'appliquer avec les téléphones cellulaires.
- * Gebührenfrei. Kosten für Anrufe aus Mobilfunknetzen können abweichen.
- * Gratis telefoonnummer vanaf vaste lijn.
- * Det er et gratis nummer, når du ringer fra fasttelefon.
- * Det är gratis, när du ringer från en fast telefon.
- * Numéro sans frais. Des frais peuvent s'appliquer avec les téléphones portables.



WIN!

Go to www.LEGOsurvey.com/product to fill out a survey for a chance to win a cool LEGO® Product.

No purchase necessary.

Open to all residents where not prohibited.



www.LEGOsurvey.com/product

GEWINNE!

Nimm an der Umfrage auf www.LEGOsurvey.com/product teil und hab die Chance ein cooles LEGO® Produkt zu gewinnen!

Die Teilnahme am Gewinnspiel führt zu keinerlei Kaufverpflichtungen. Teilnahme in allen nicht ausgeschlossenen Ländern möglich.

WIN!

Ga naar www.LEGOsurvey.com/product, vul een enquêteformulier in en maak kans op een cool LEGO® product.

Geen aankoopverplichting. Iedereen mag deelnemen, uitgezonderd ingezetenden van landen waar een enquêteverbod geldt.

GAGNE!

Visite www.LEGOsurvey.com/product pour répondre à un questionnaire et avoir une chance de gagner un produit LEGO® très cool!

Aucune obligation d'achat. Ouvert à tous les résidents des pays autorisés.

当てよう!

www.LEGOsurvey.com/product にアクセスして、アンケートにご記入ください。当選者にはレゴ®製品を差し上げます。

お買い上げの必要はありません。禁止されていない限り、すべての皆様にご利用いただけます。