

# BIONICLE

[www.bionicle.com](http://www.bionicle.com)



8623  
KREKKA





# BIONICLE

## METRU NUI

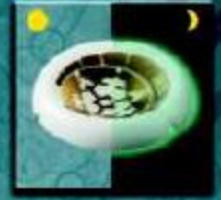



# BIONICLE

# 1



60120

Kretzler

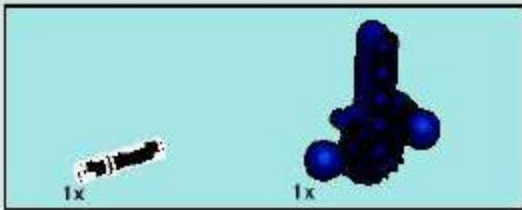
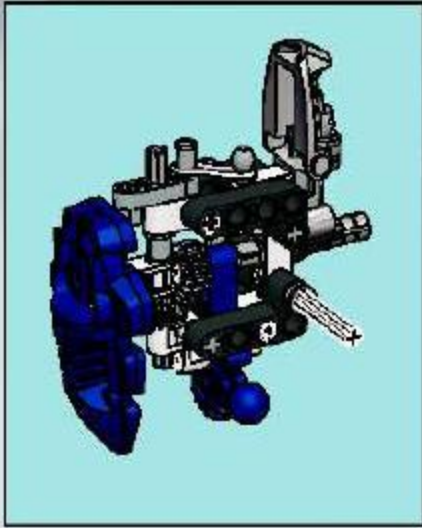

# 1

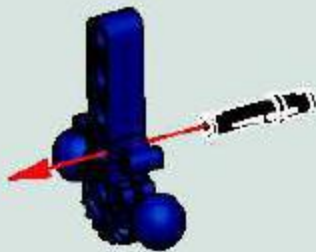

# 2

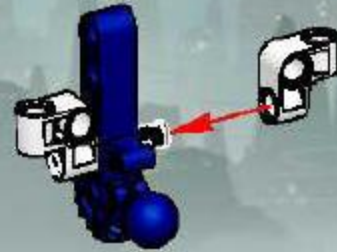

# 3

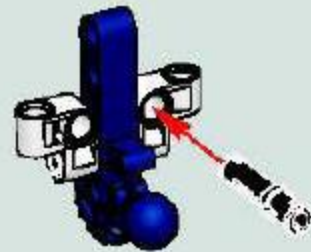



4

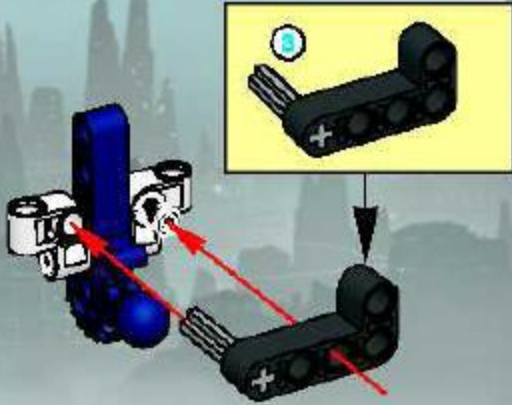

5

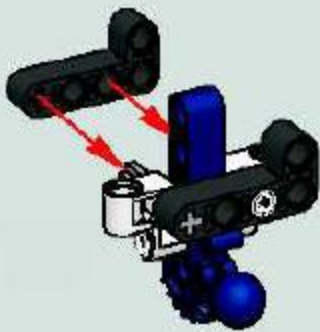

6

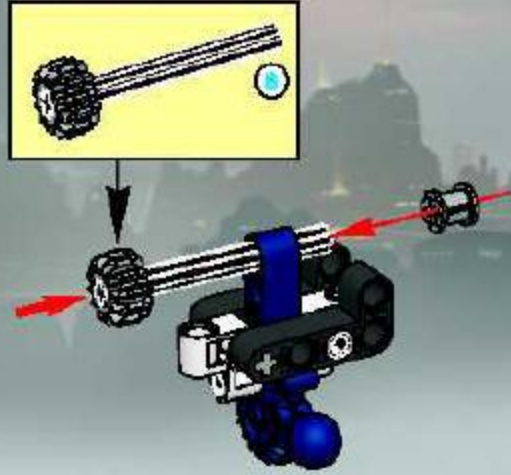

7

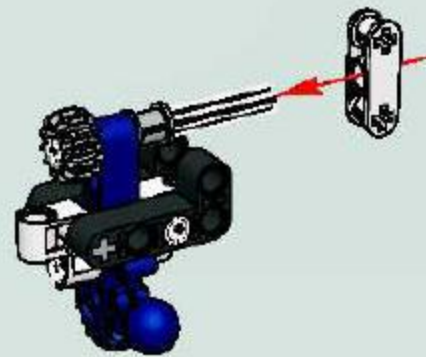

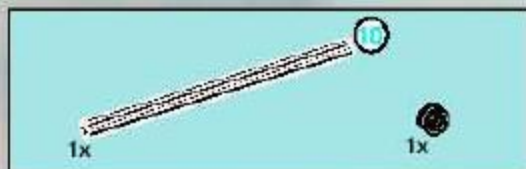

8

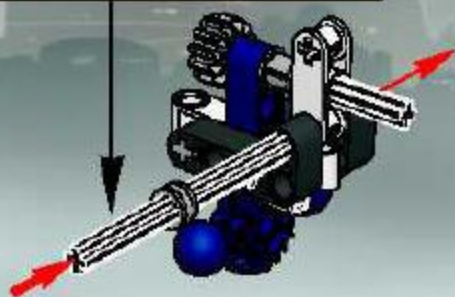
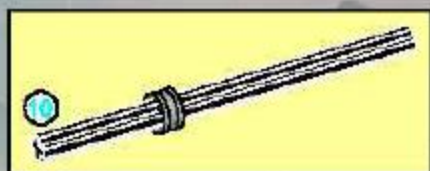

9

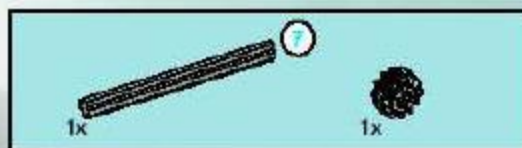
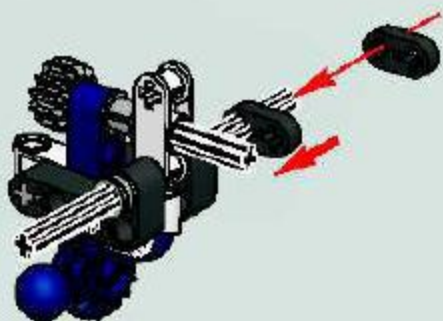

10

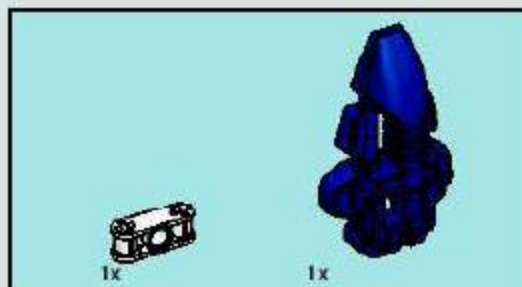
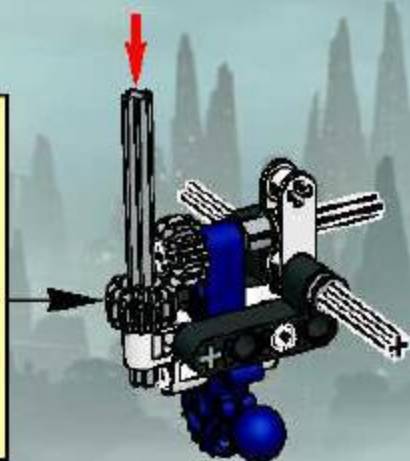

11

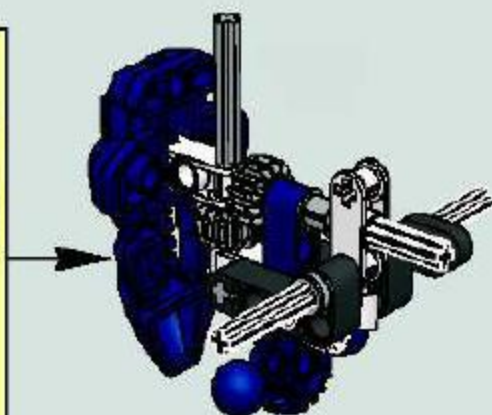





2x

# 12

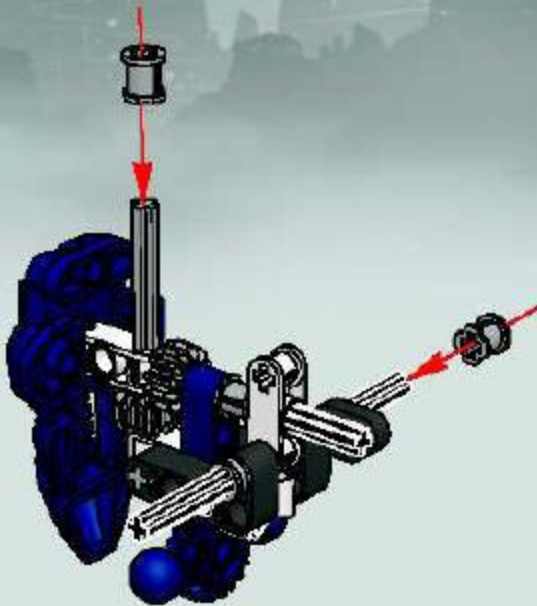

1x

1x



1x



2x

# 13

1



2

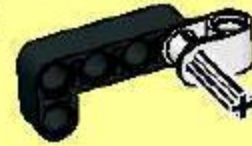

3

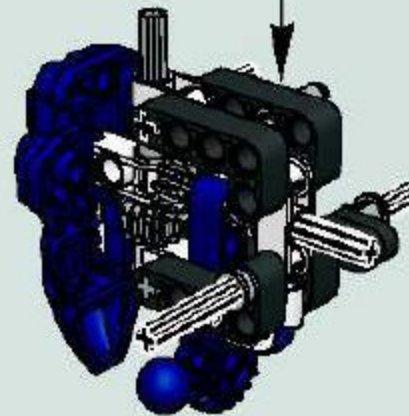
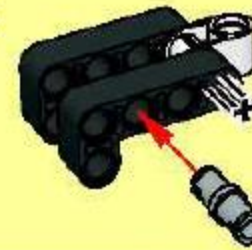



14

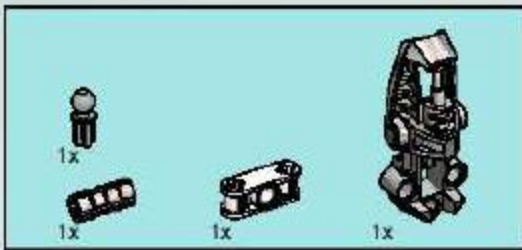
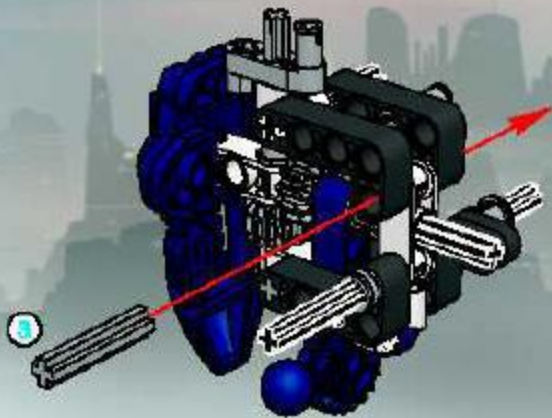

15

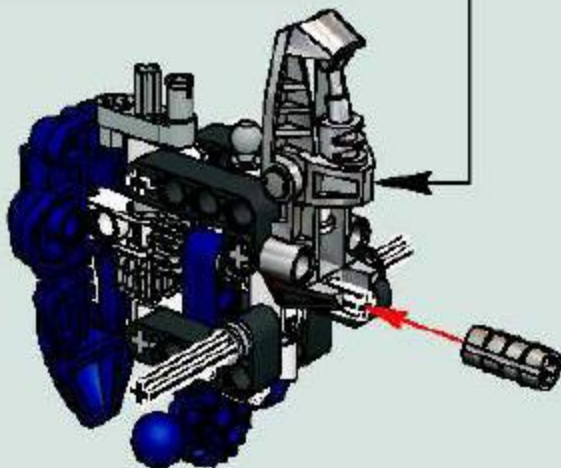
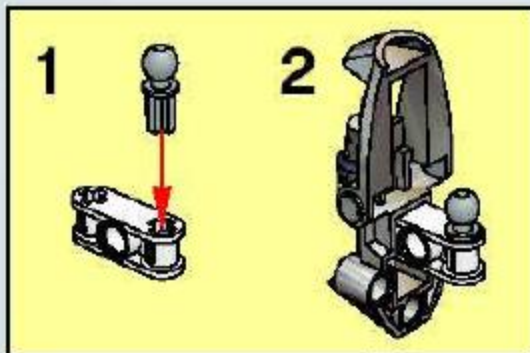

16

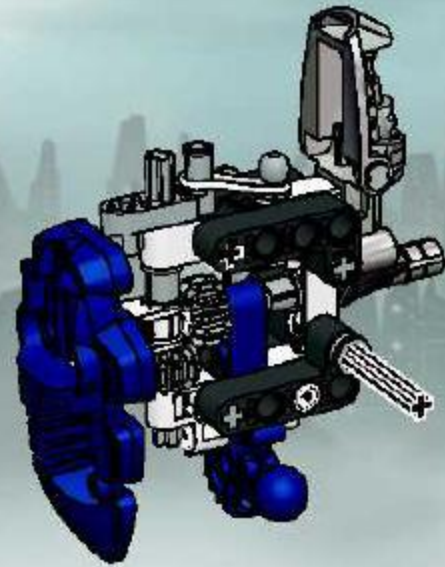

17

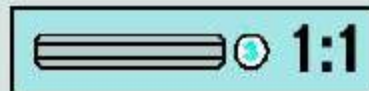
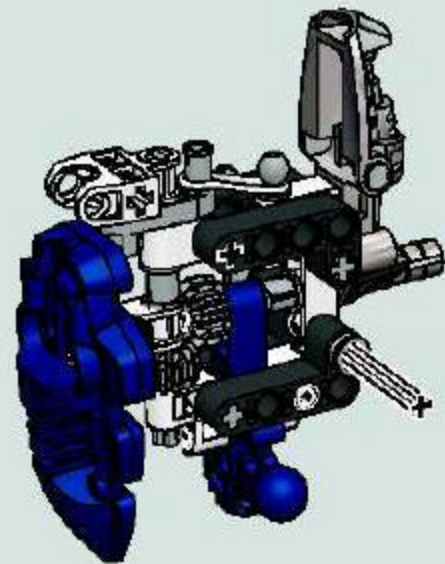

# BIONICLE

## 2



98622

Kredica

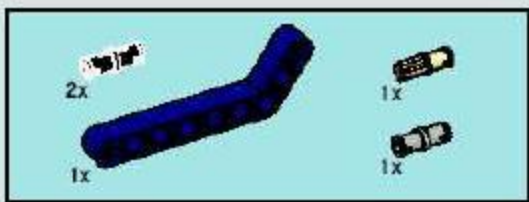
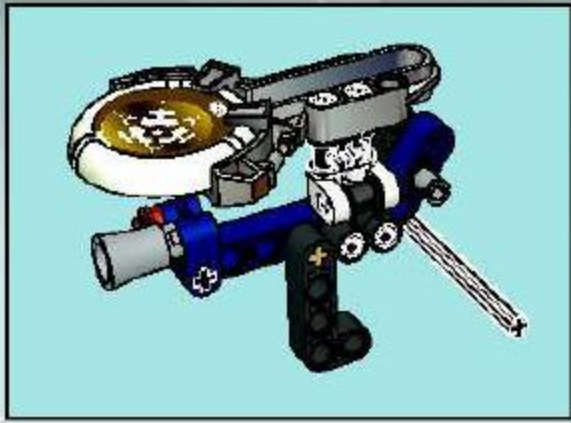

1



2



3

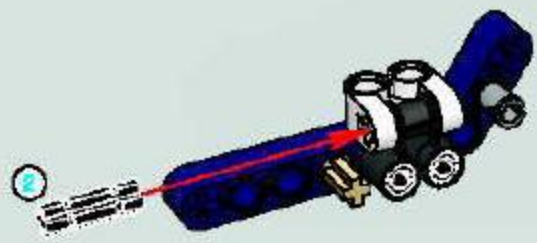





4

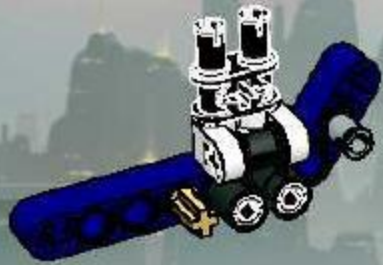

6

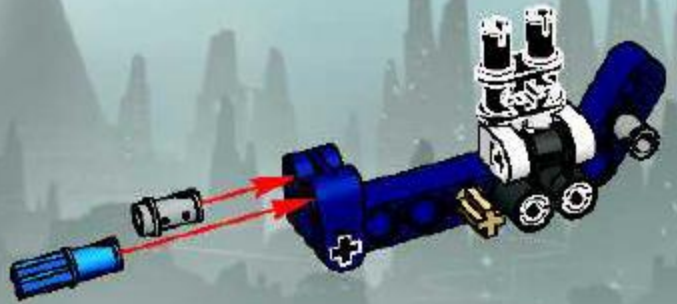

5

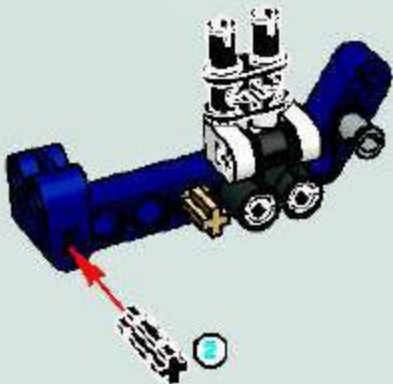

7

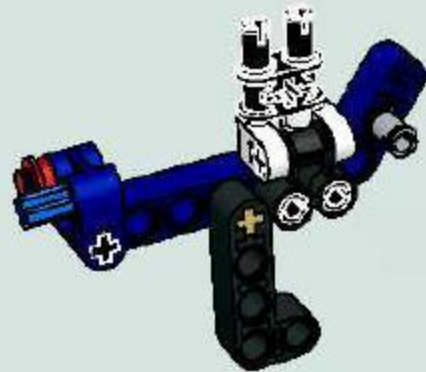

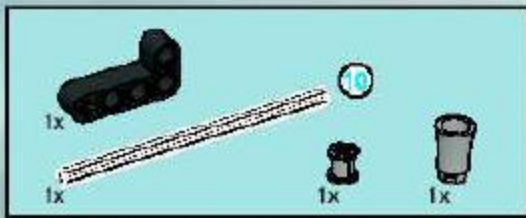

8

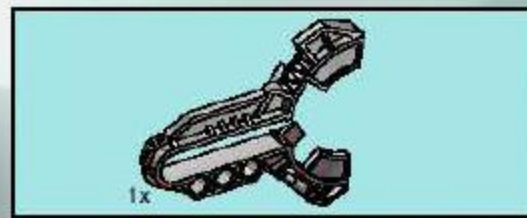
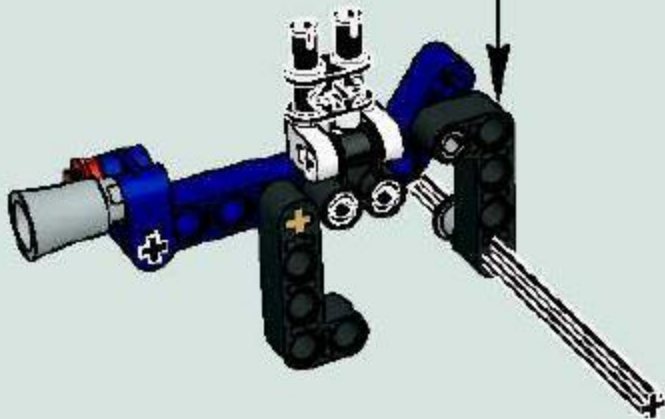
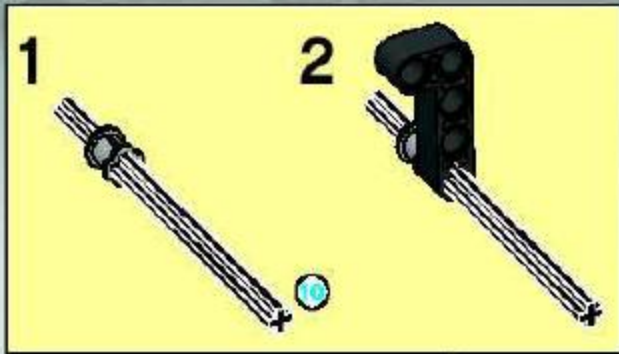

9

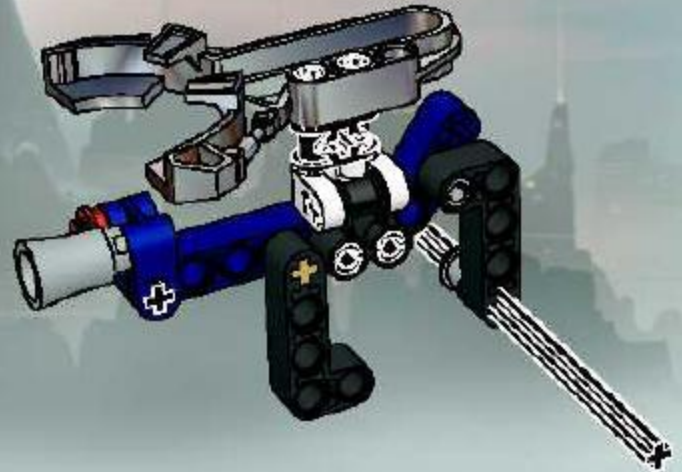

10

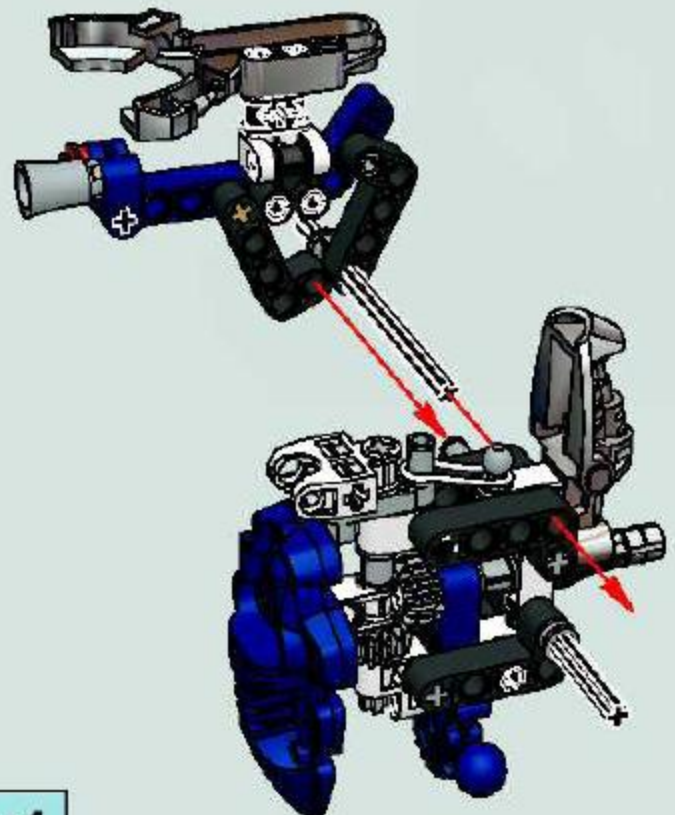





11

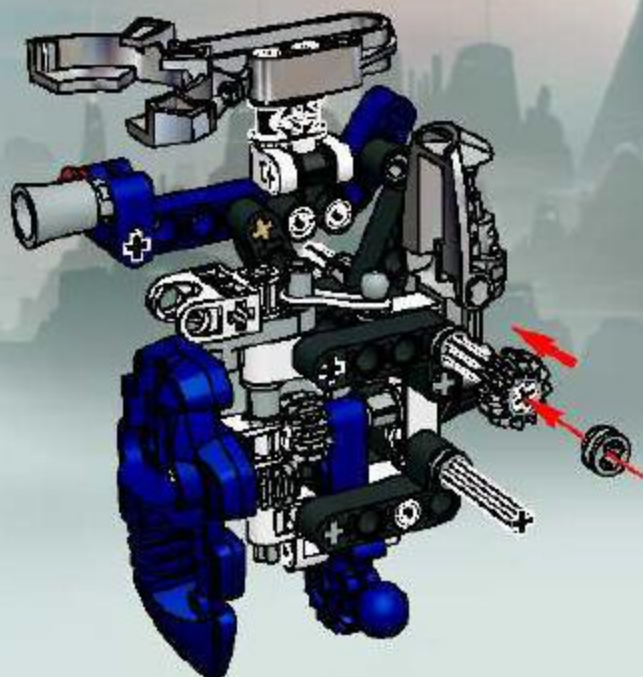

12

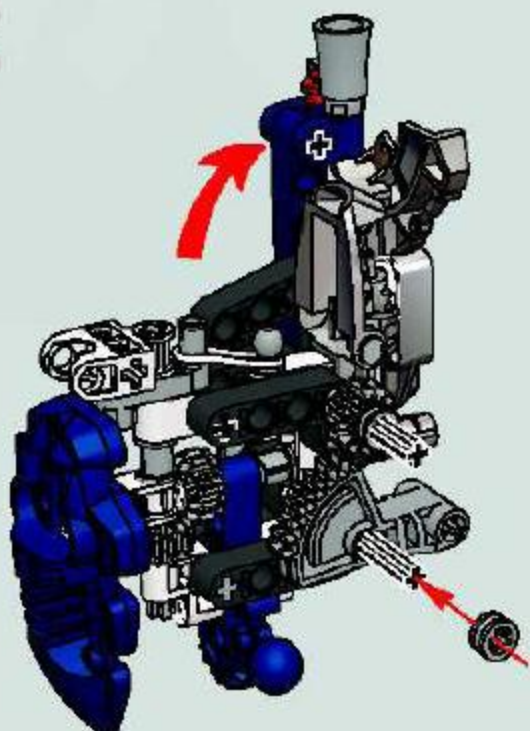

13



14

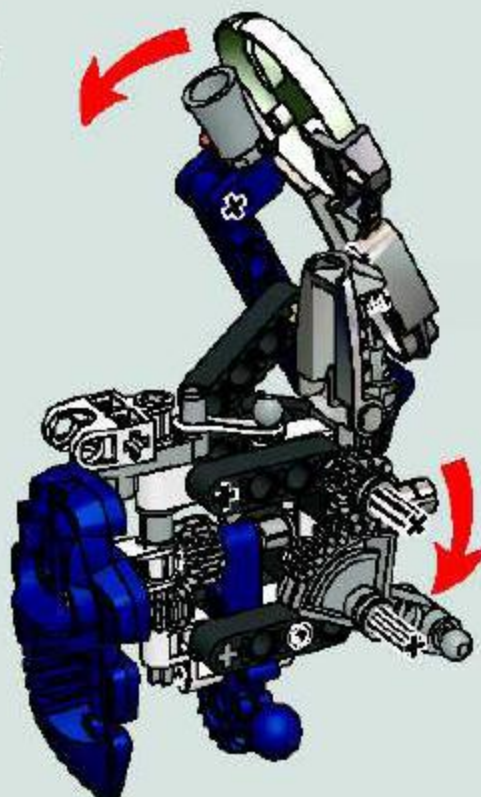

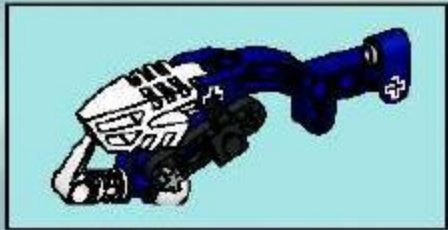

1



2



3



4

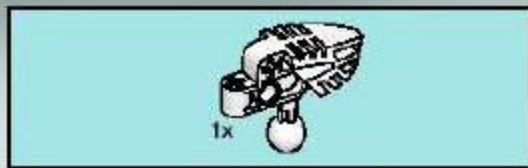

5

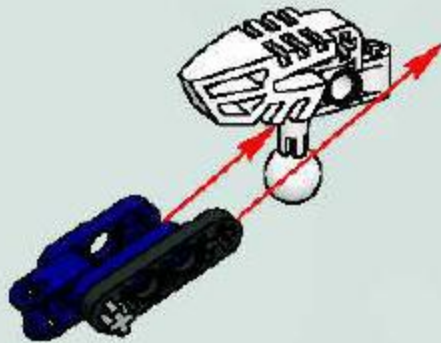

6

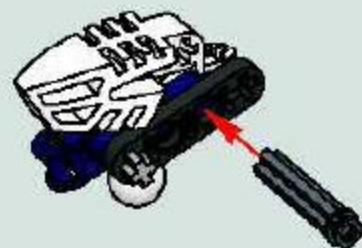





1x

7

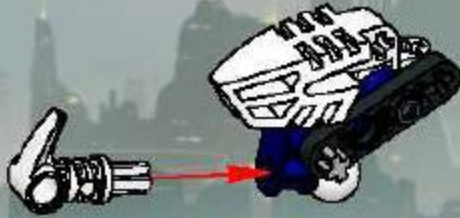

1x



1x



1x

9

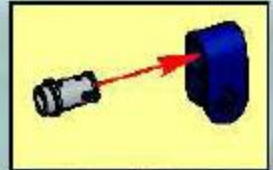

2x



1x

8

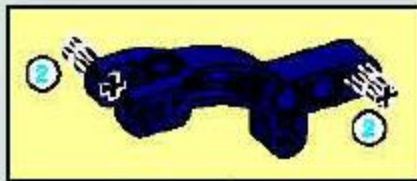

1x



1x

10

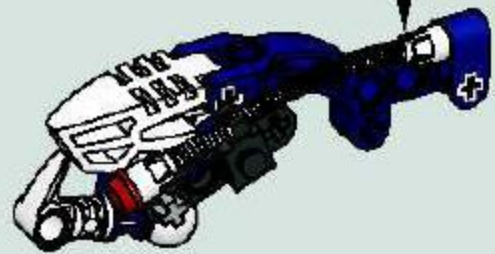
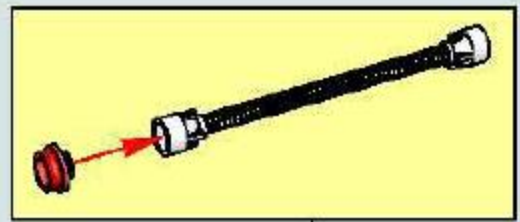

11

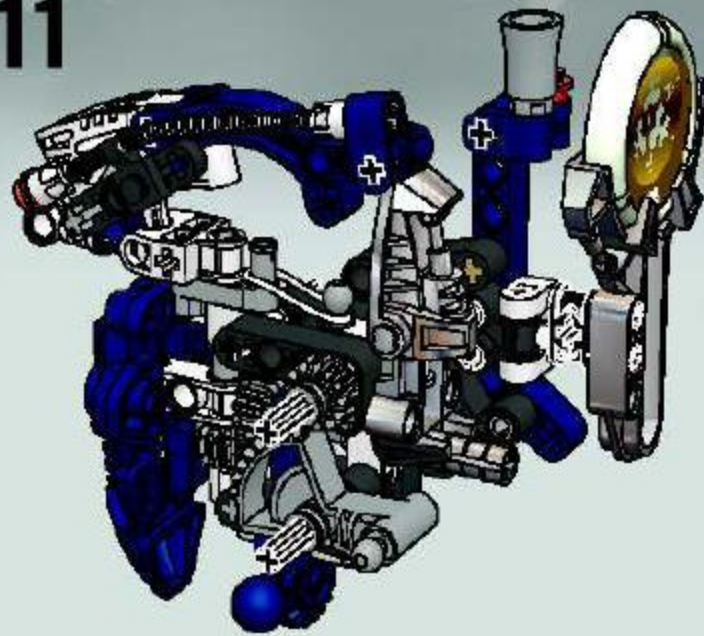



# BIONICLE™

# 3

LEGO

60122

Kretzlin

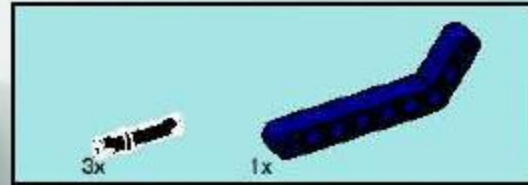

# 1



# 2

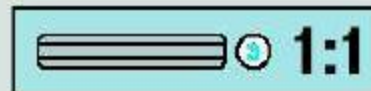
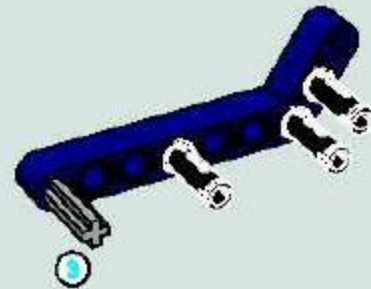



3

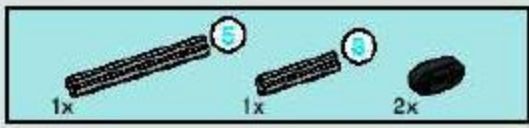

4

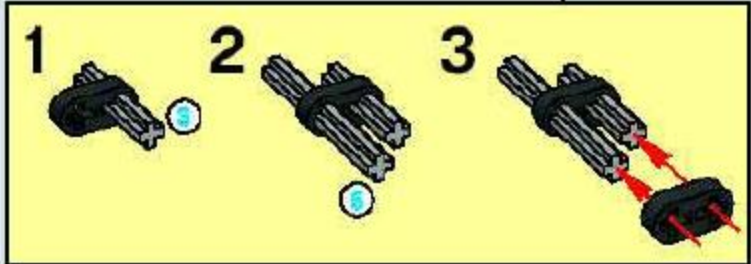
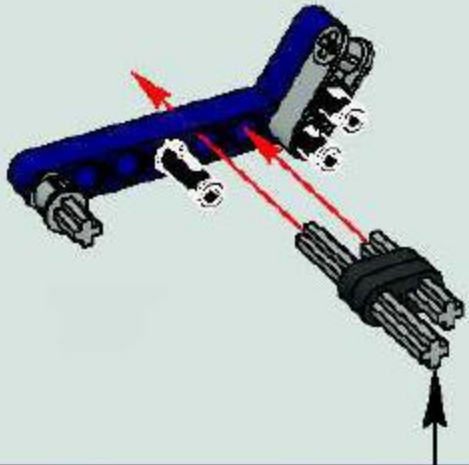

5

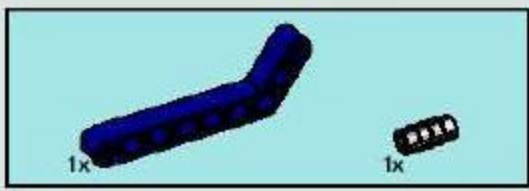
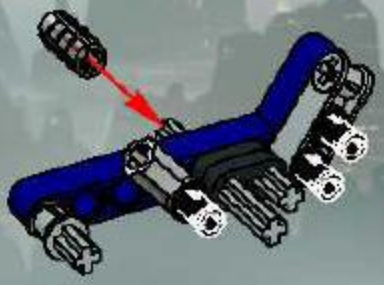

6

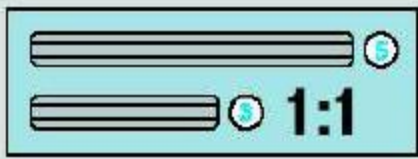
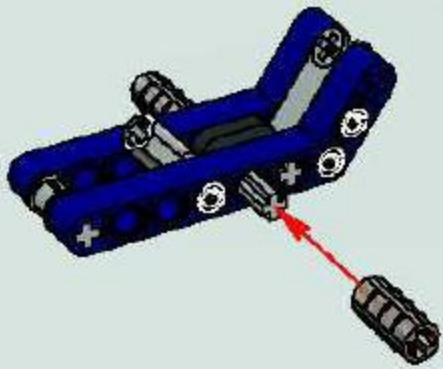





7

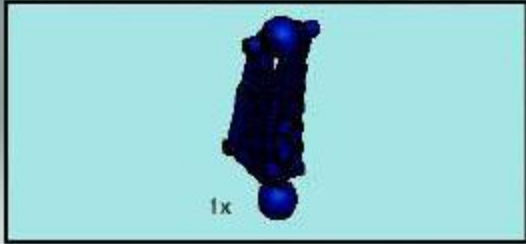
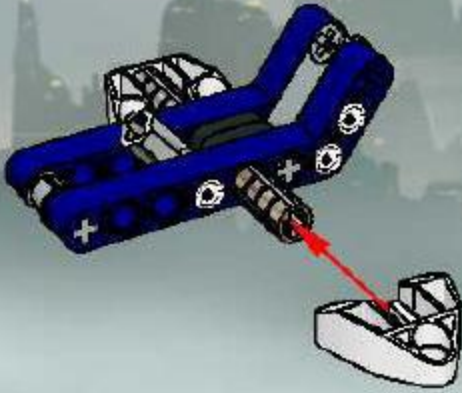

9

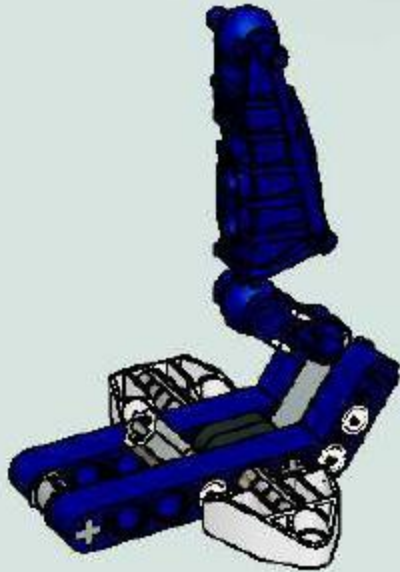

8

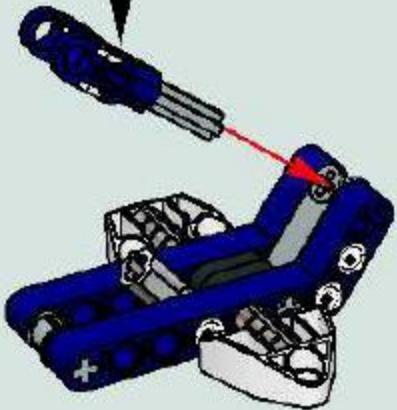

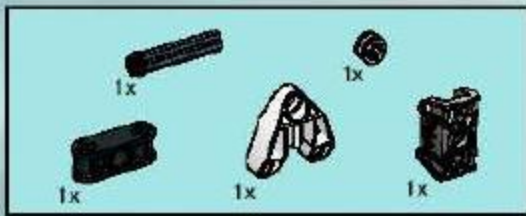

10

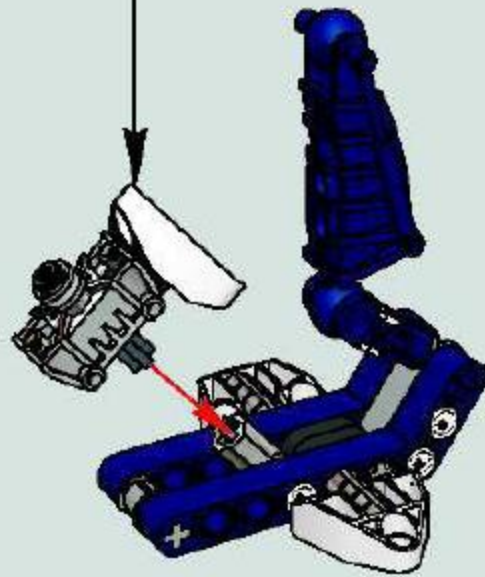
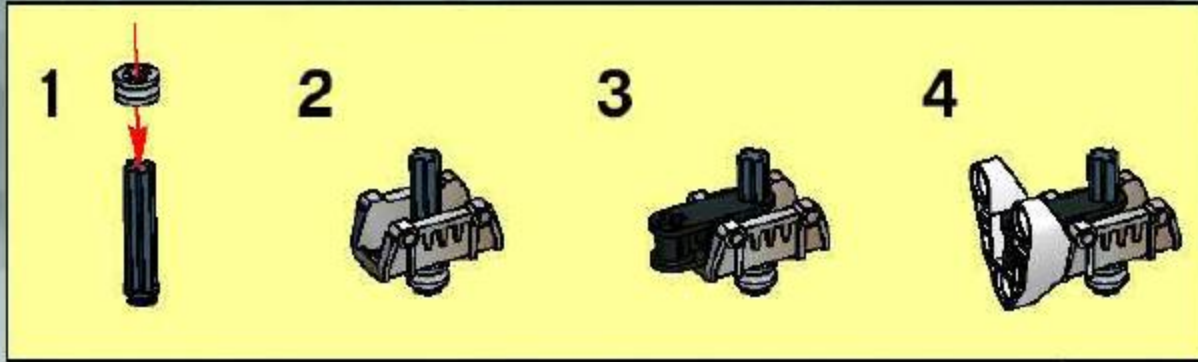





11



12

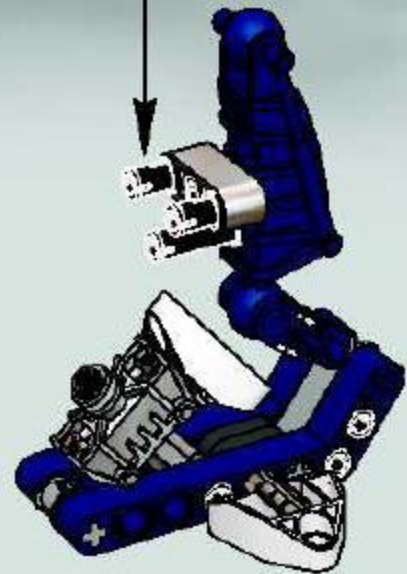
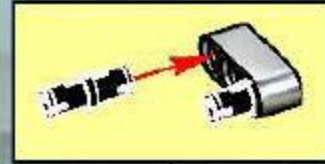

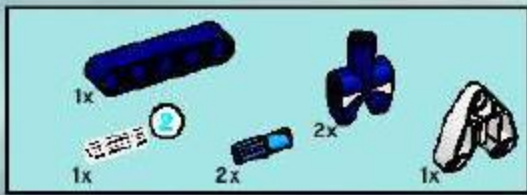

13

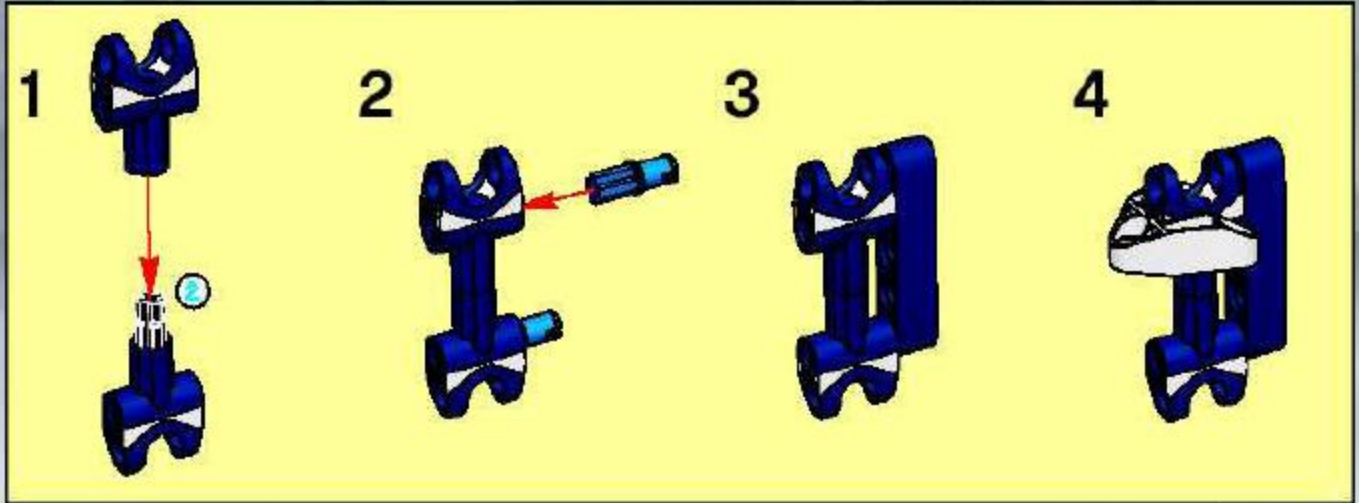





14



2x

15

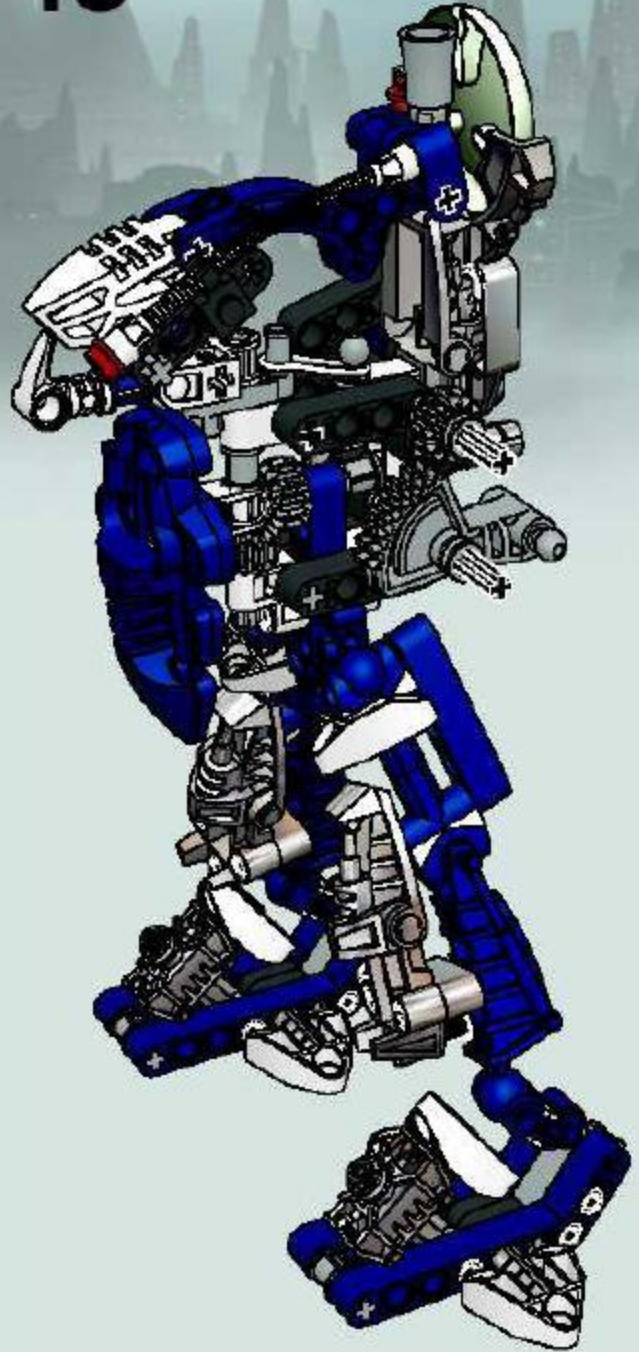

# BIONICLE

## 4



2022 Kretzler

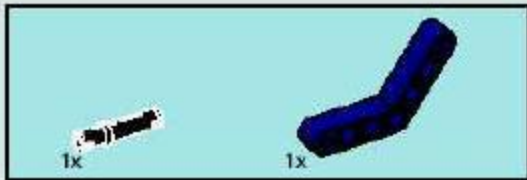
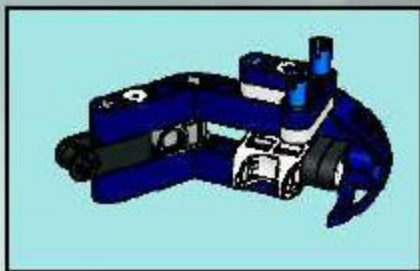

1

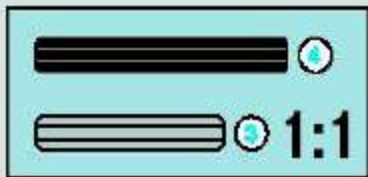
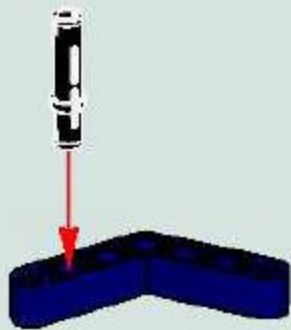

2



3







4

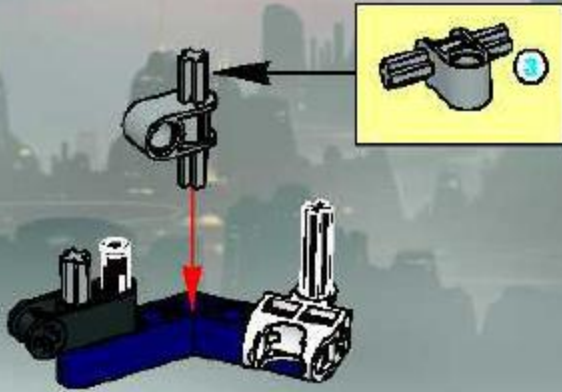

6

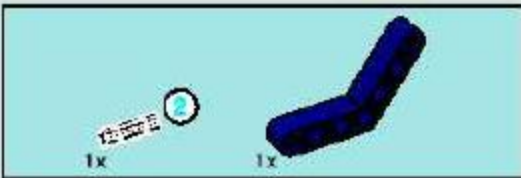

5



7

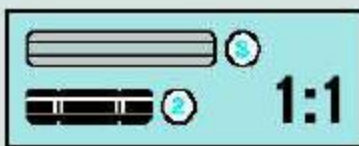
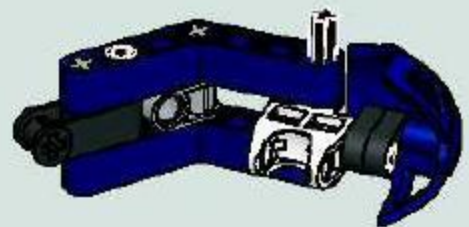



8

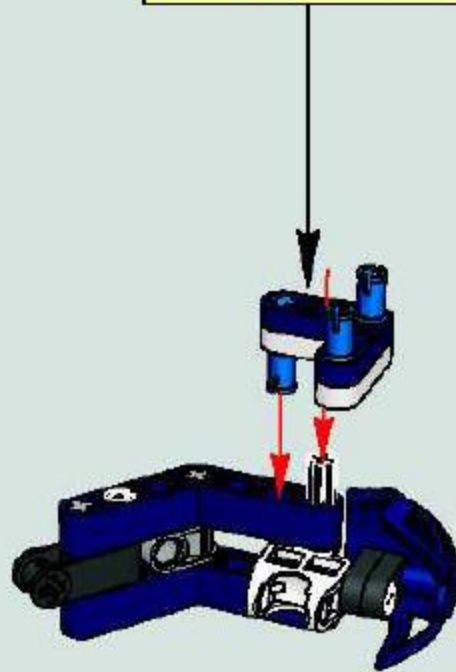
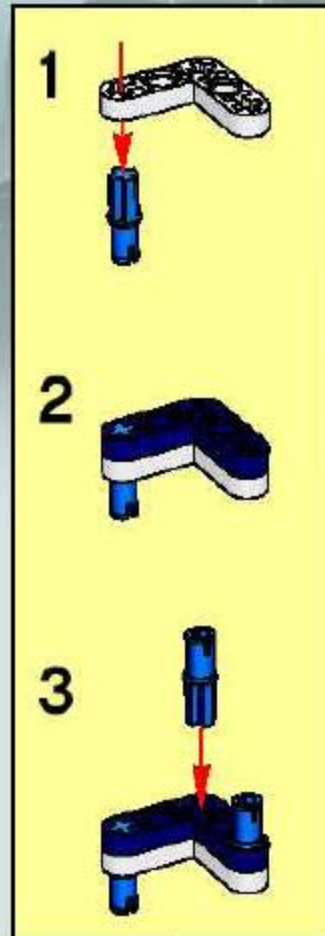



9

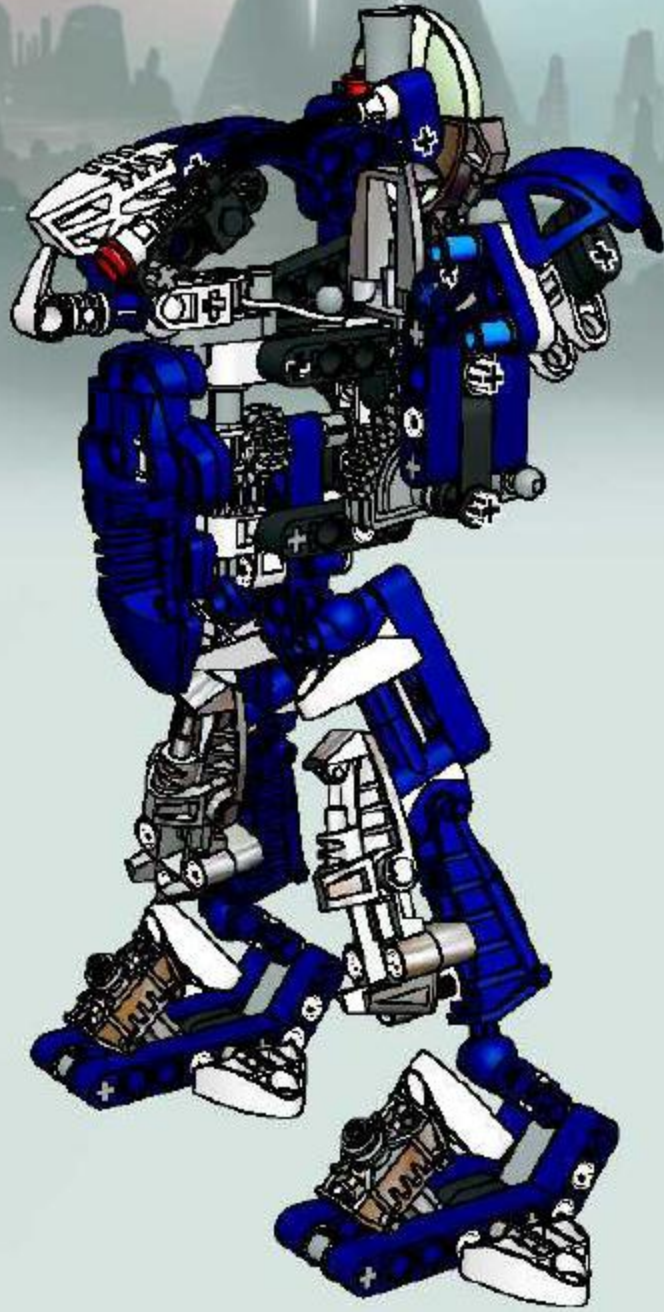



2x

# 10

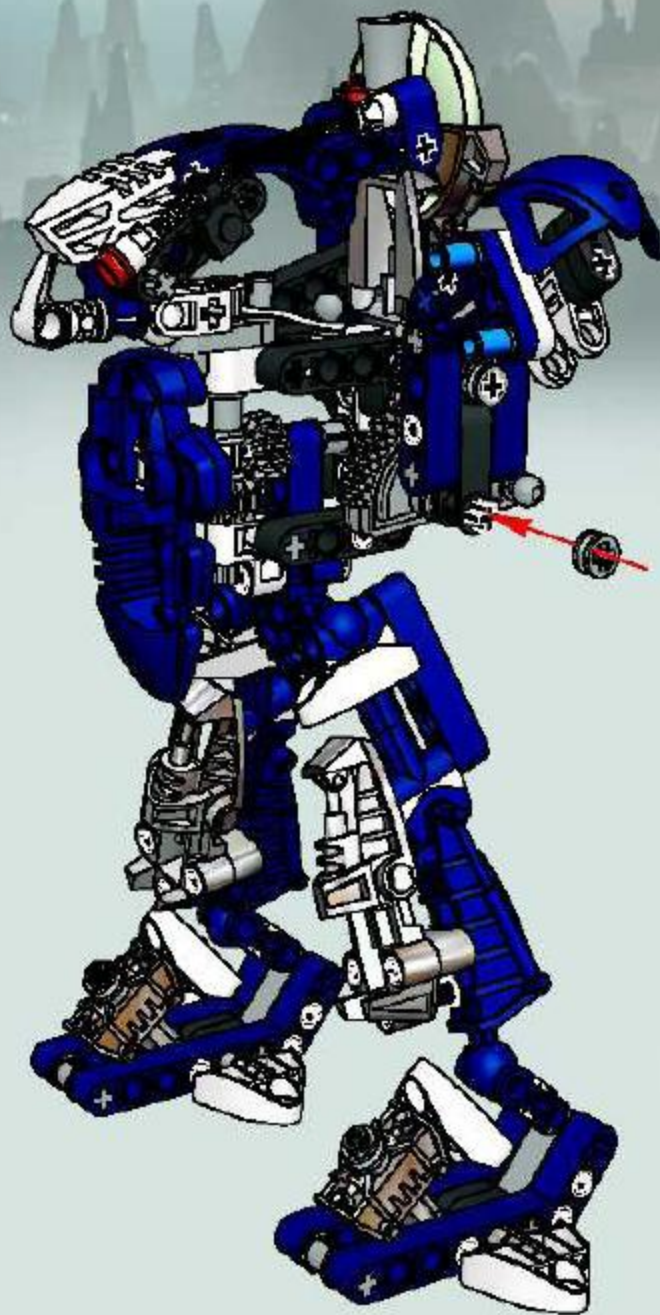



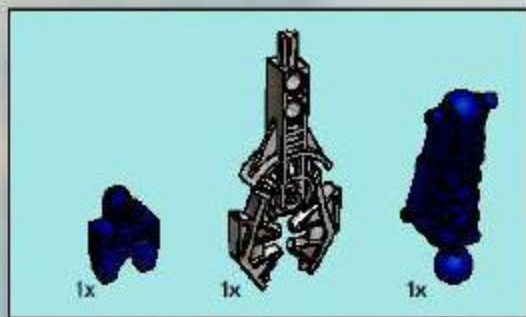

11

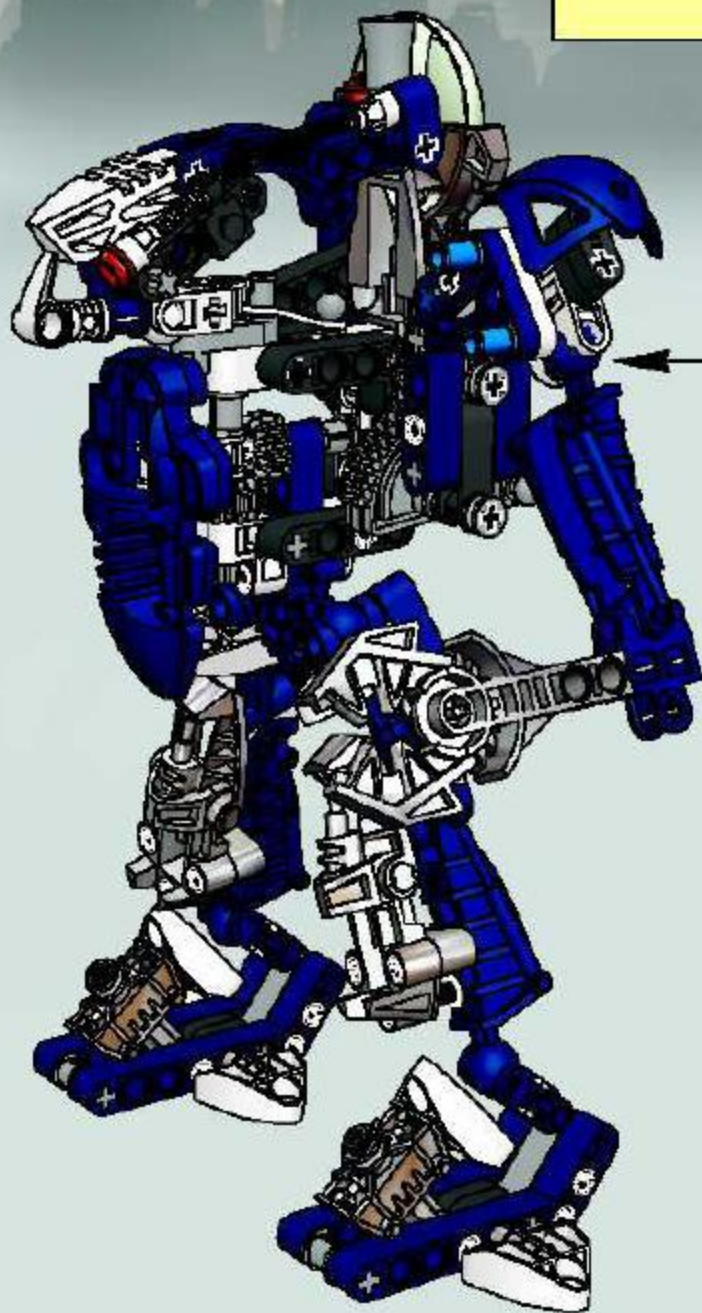
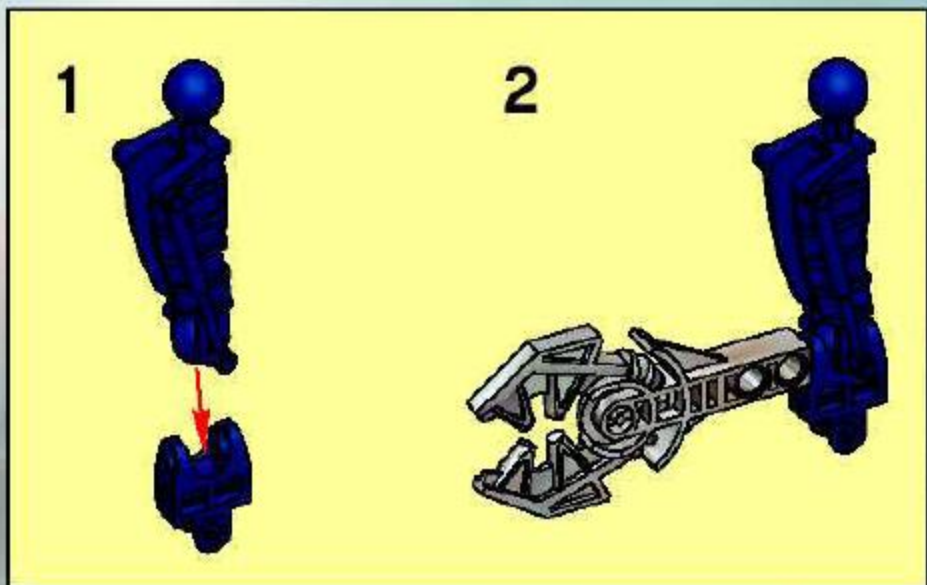

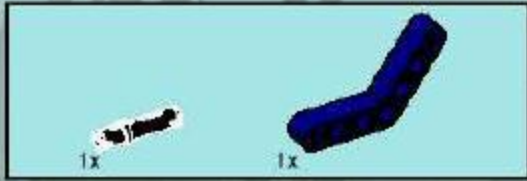
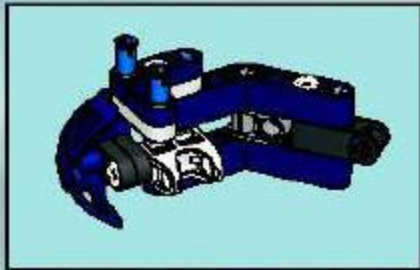

1

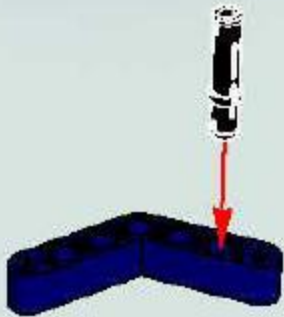

2



3

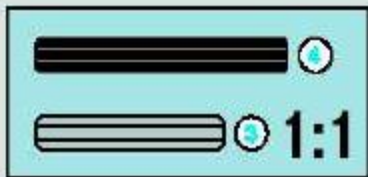
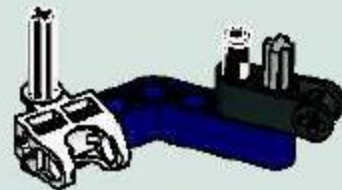





4

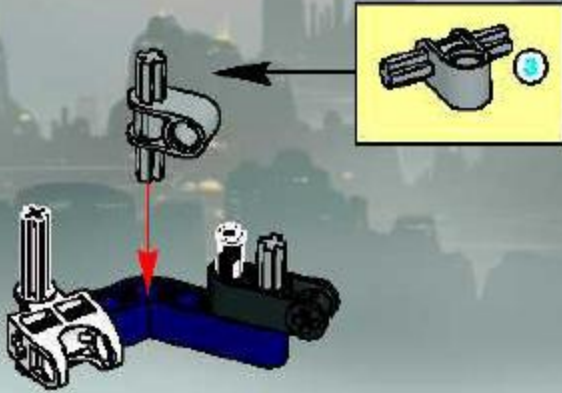

6

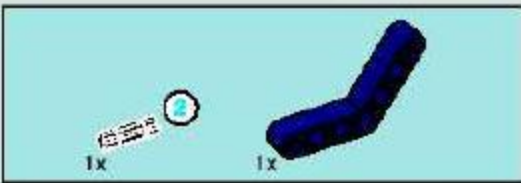

5

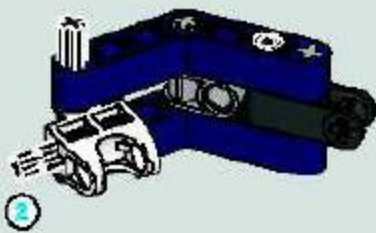

7

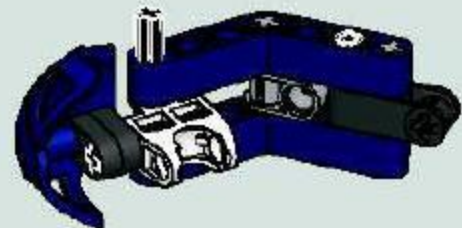



# 8

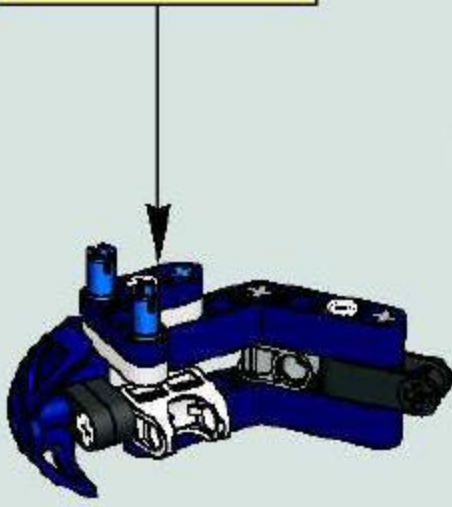
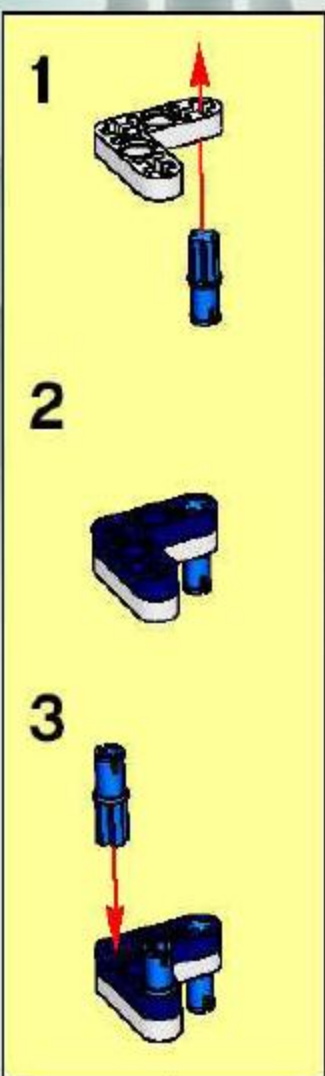



9

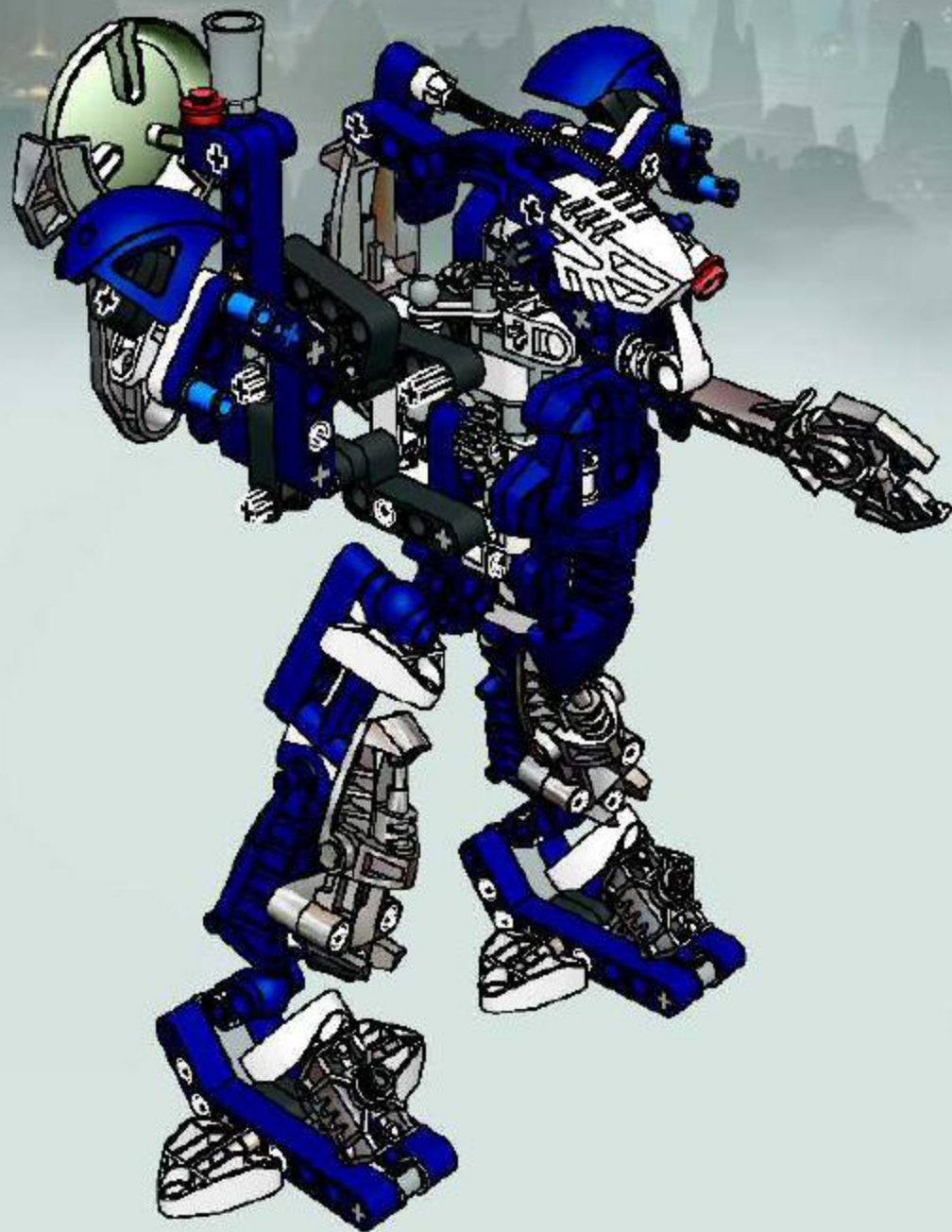

2x

10

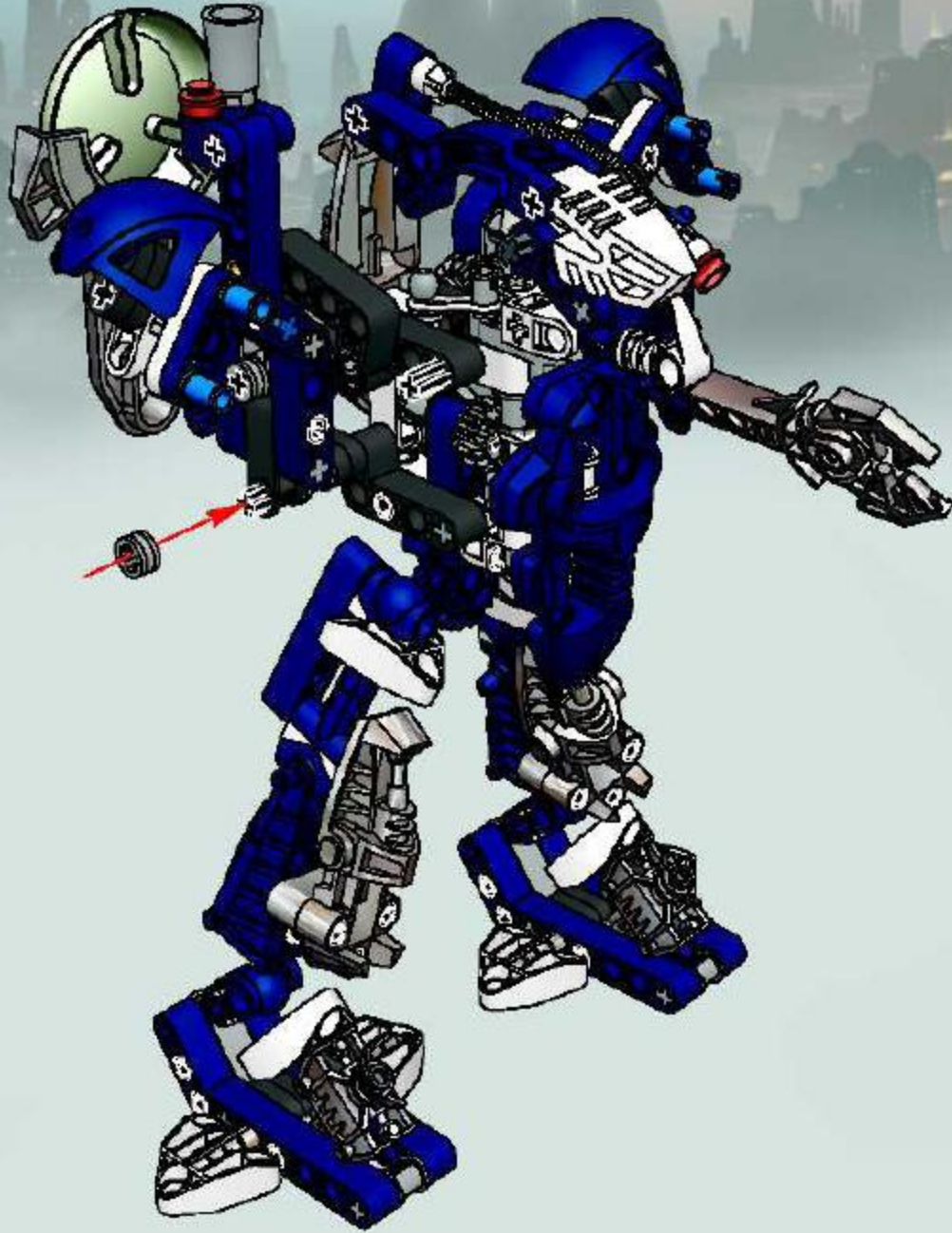



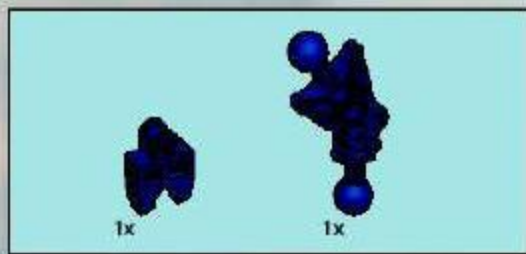

11

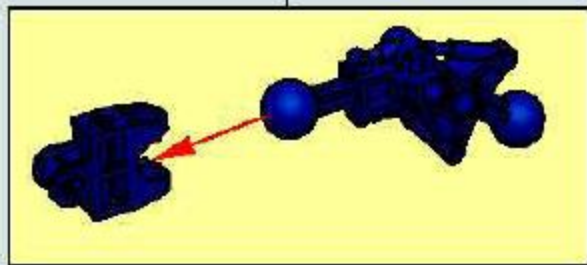

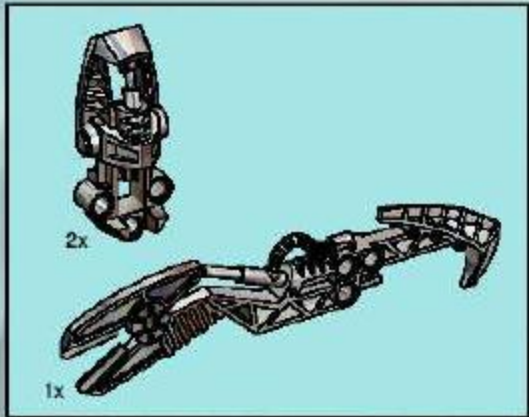

12







8621  
TURAGA DUME  
& PIVAWAK



8622  
NIDHIKI





+



+





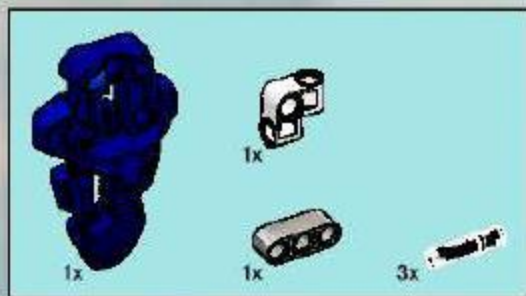

18

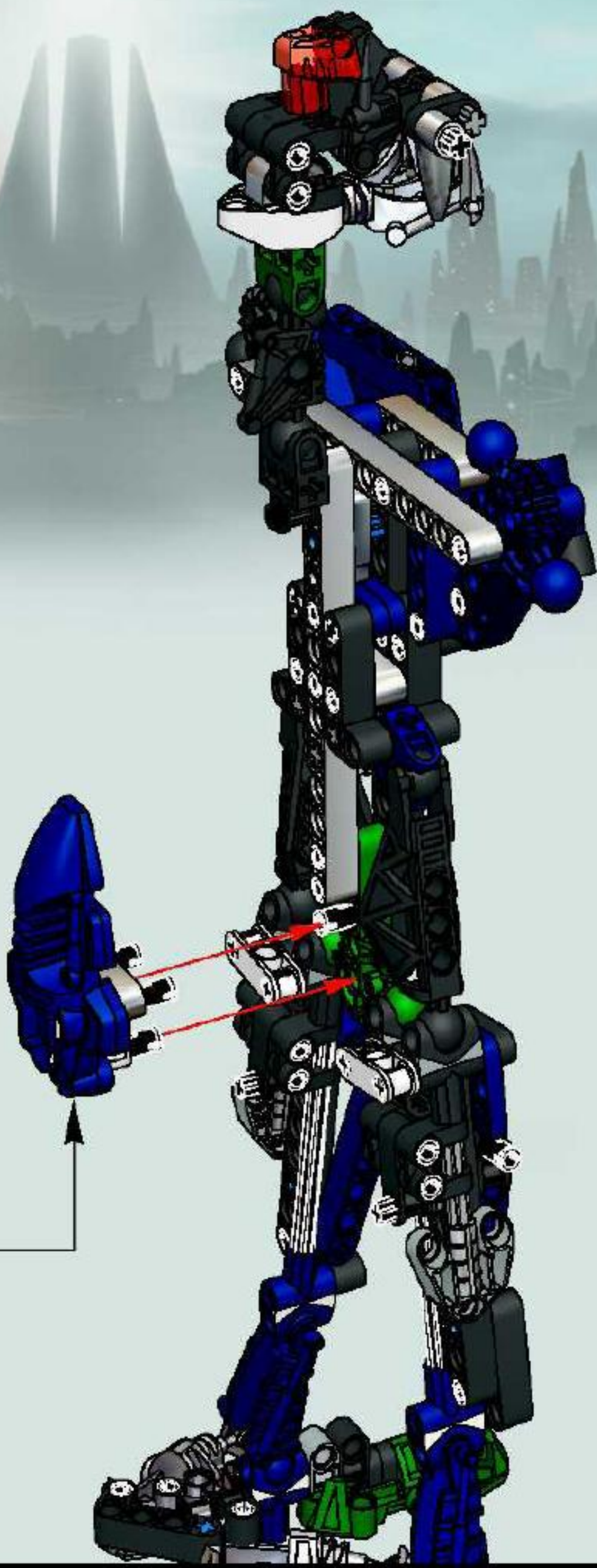
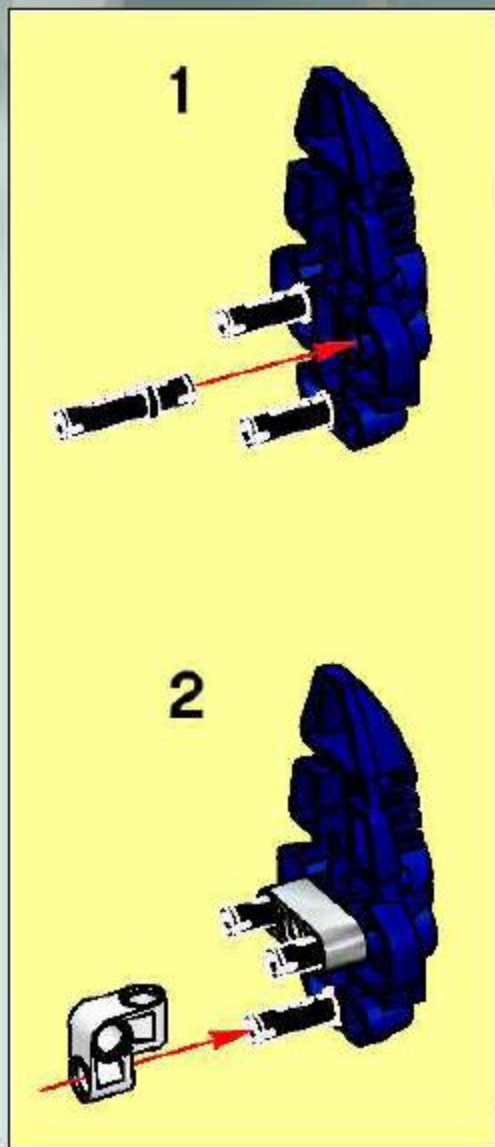

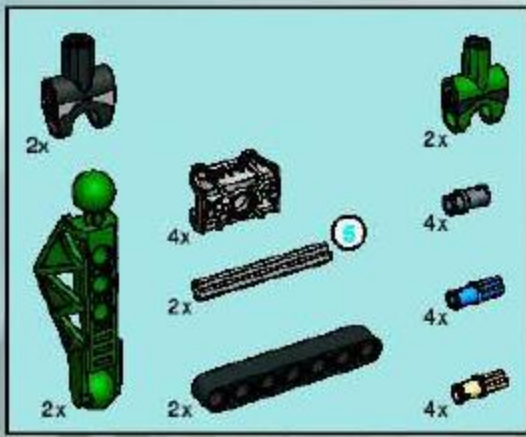

19

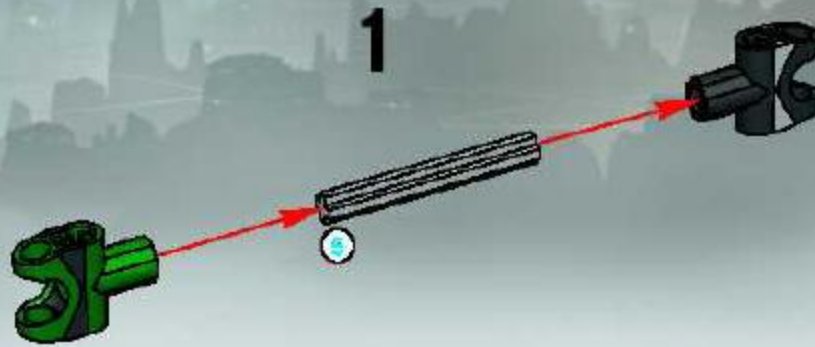

2

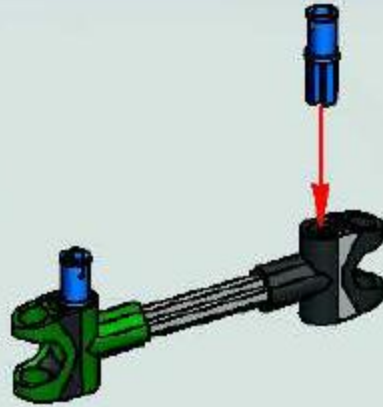

3

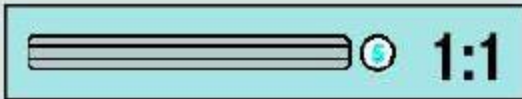



4



5

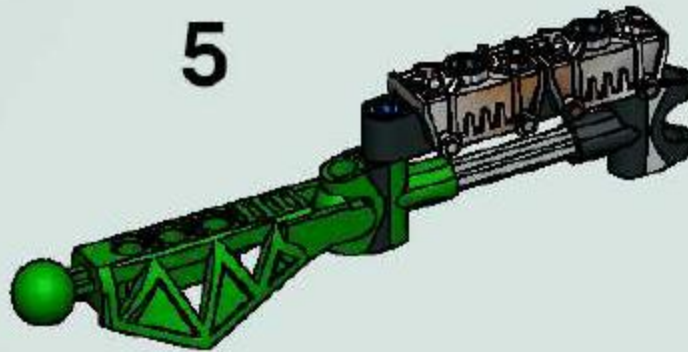

6

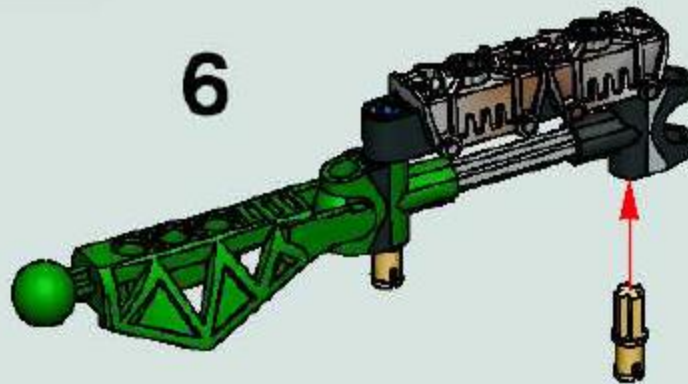

---

2x







20

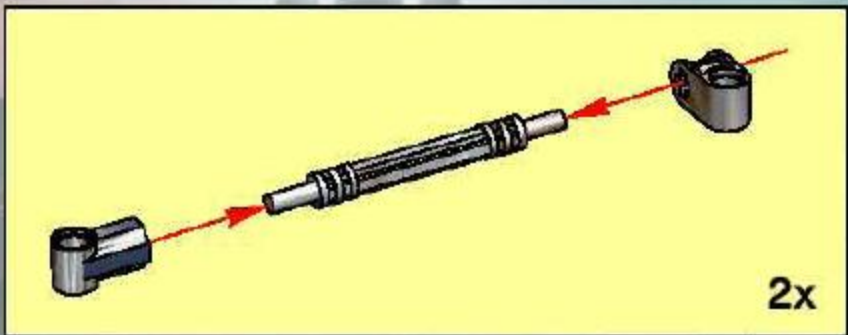



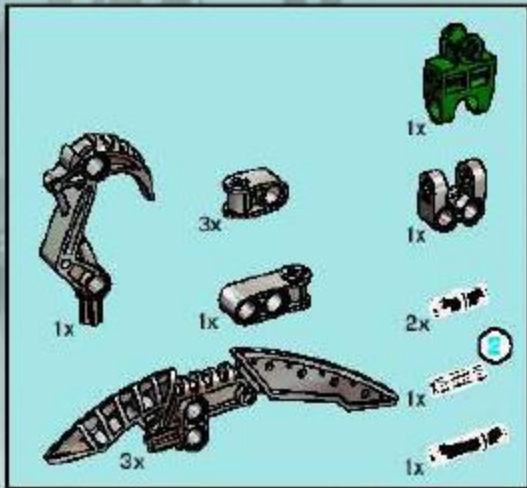
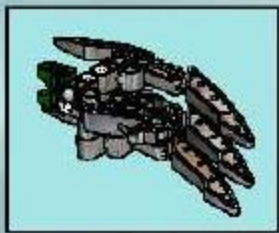

21

1

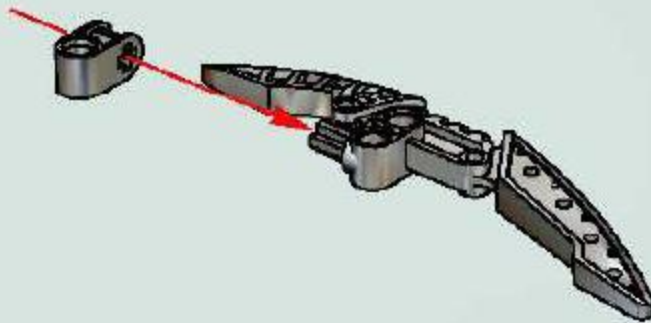

2

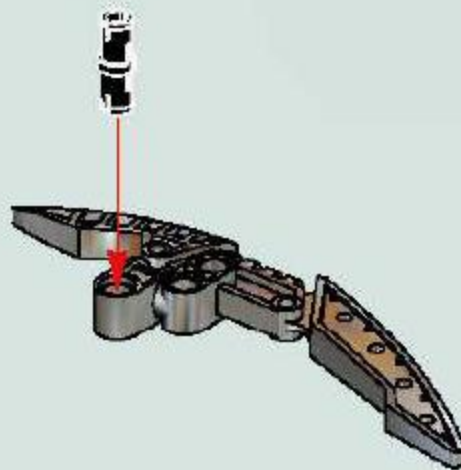

3

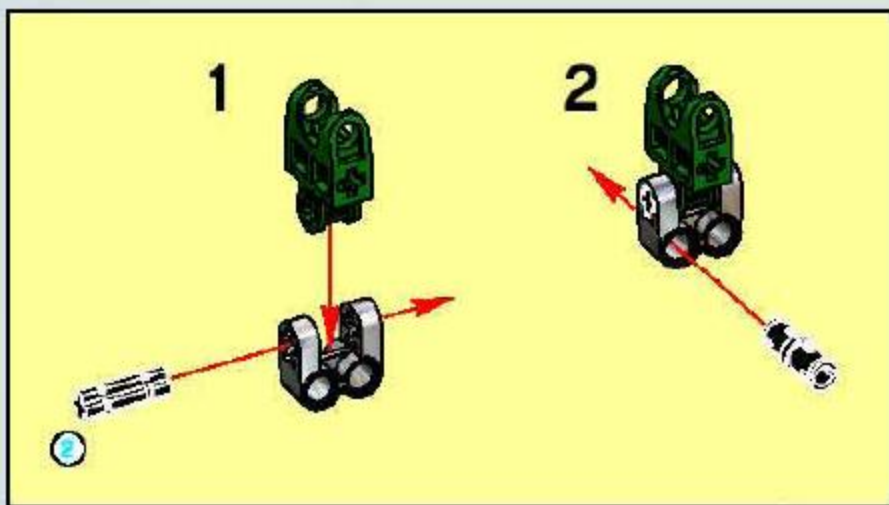
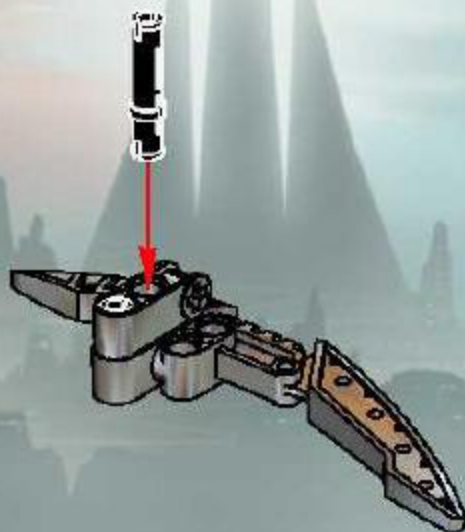

4

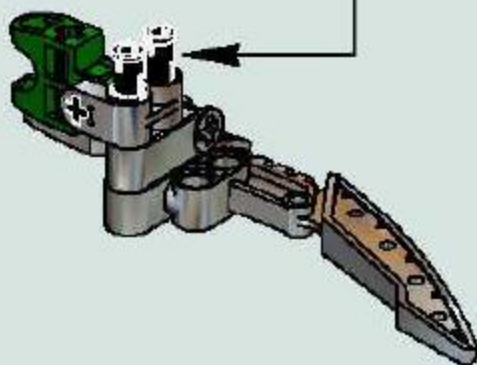

5

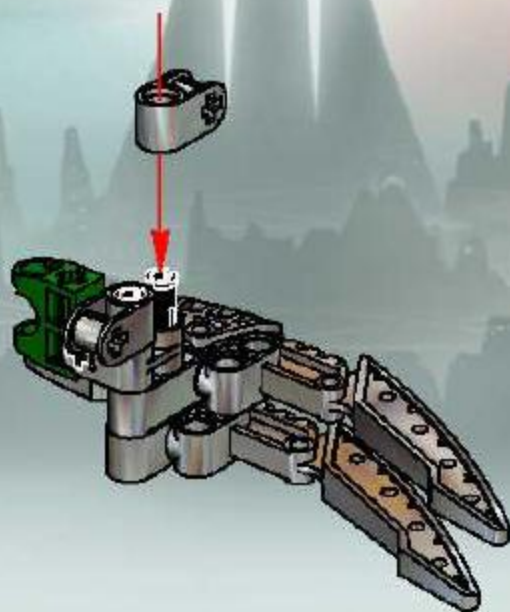

6

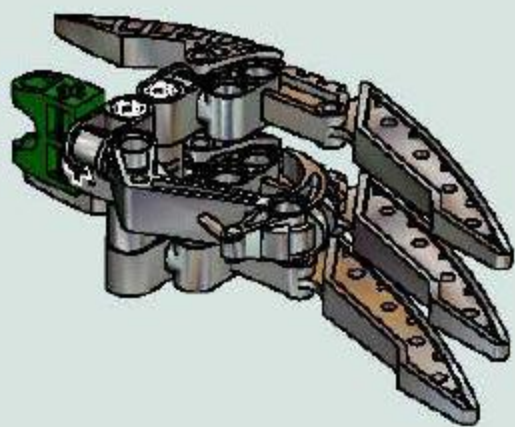



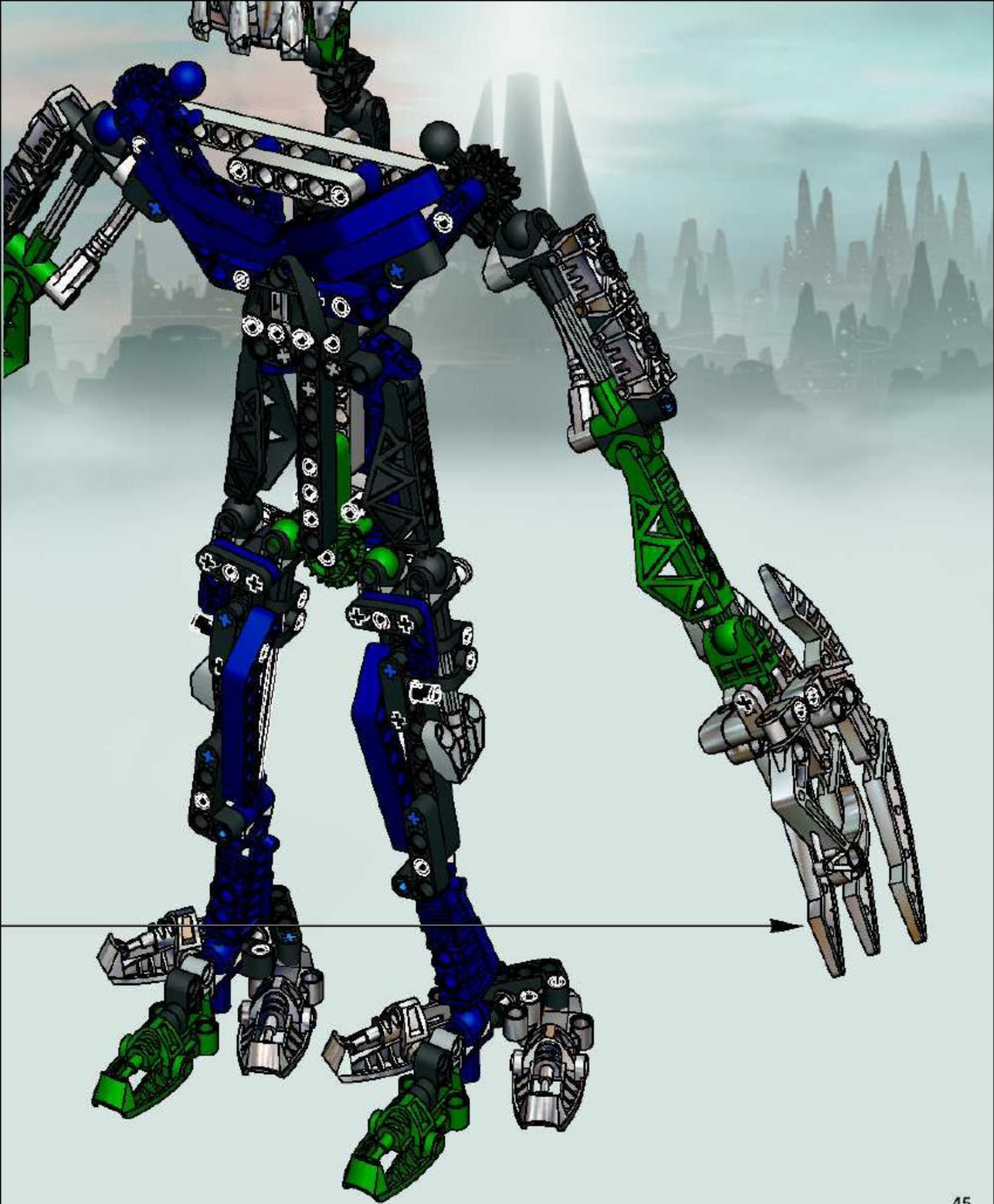



1

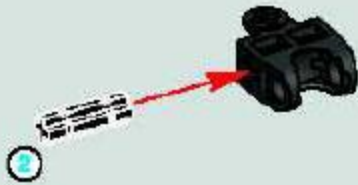

2



3



4



5

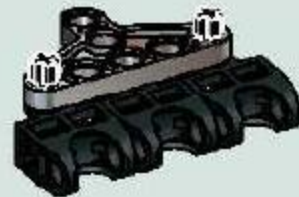



2x



6



3x



2x



7

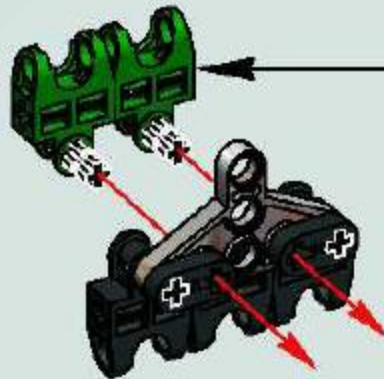
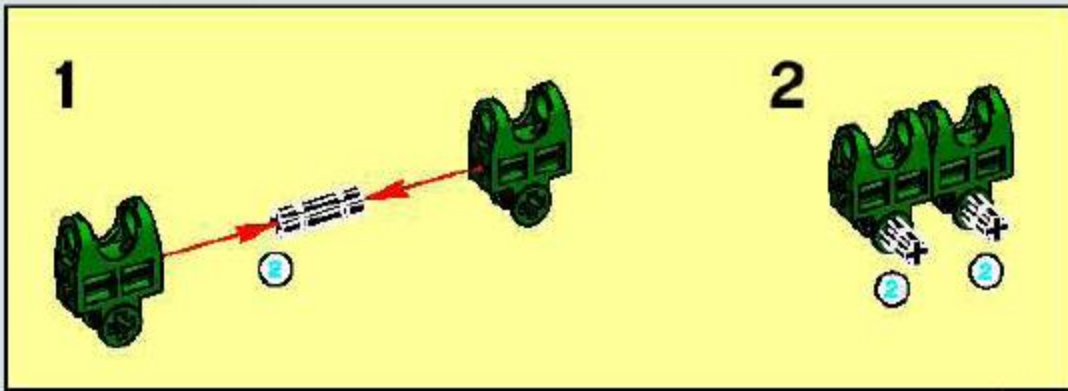

1:1

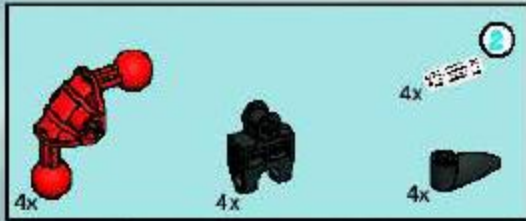

8

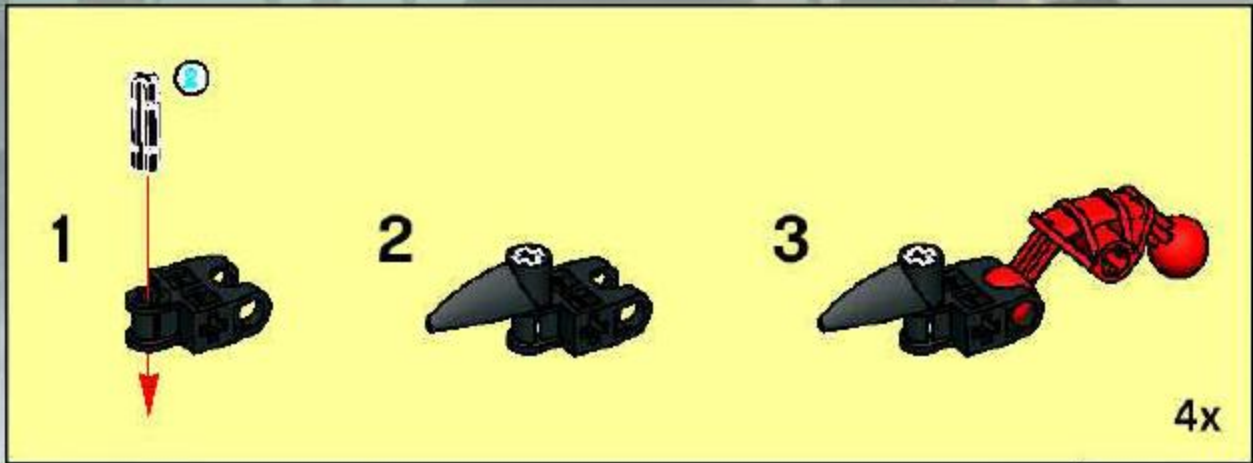



22

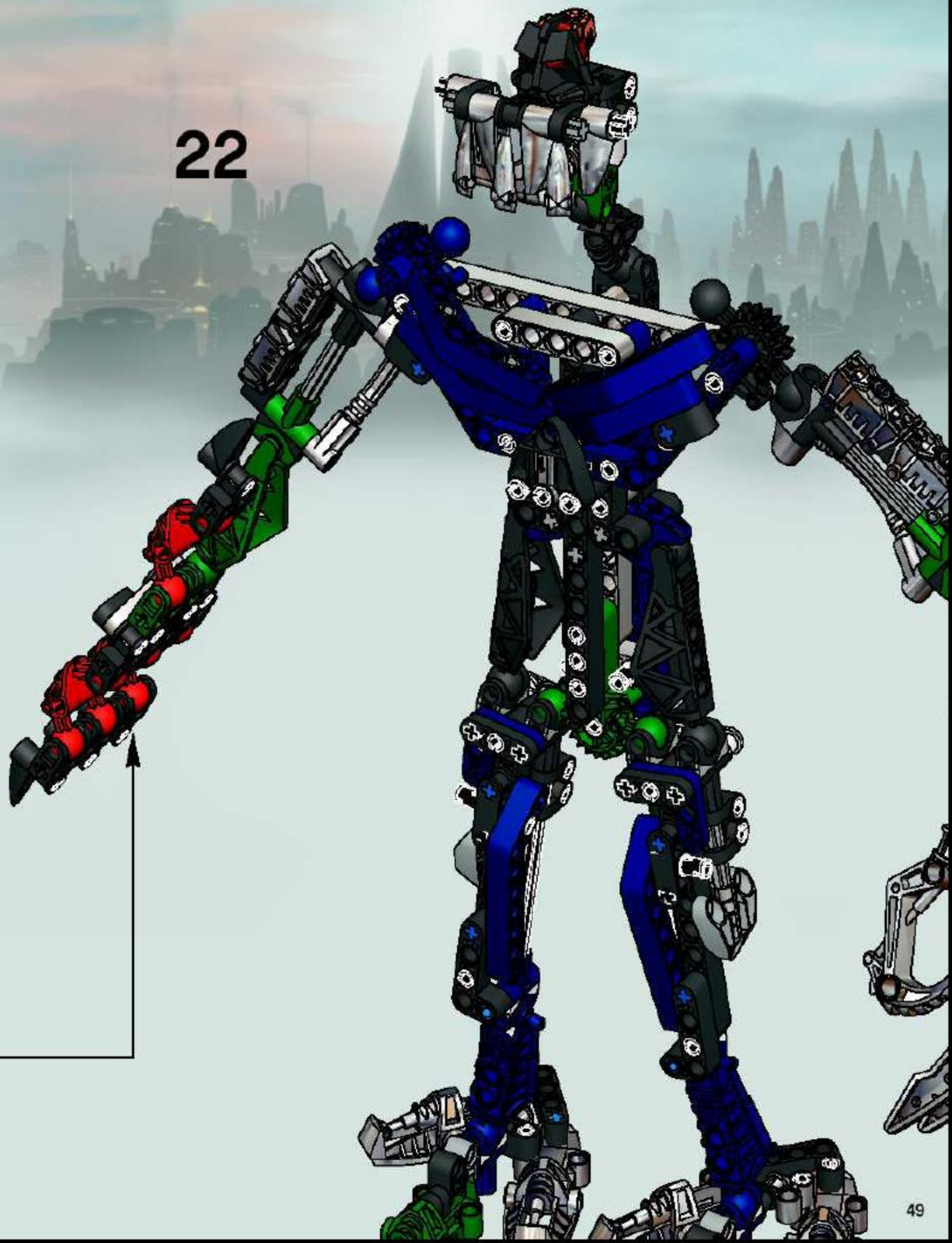

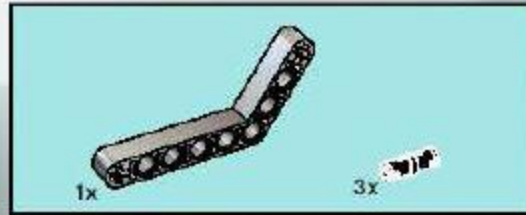
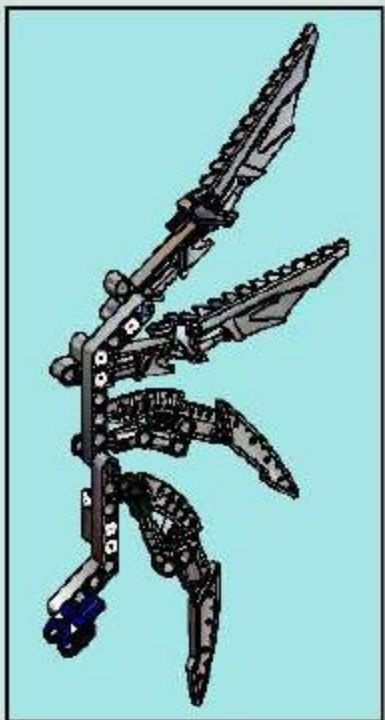
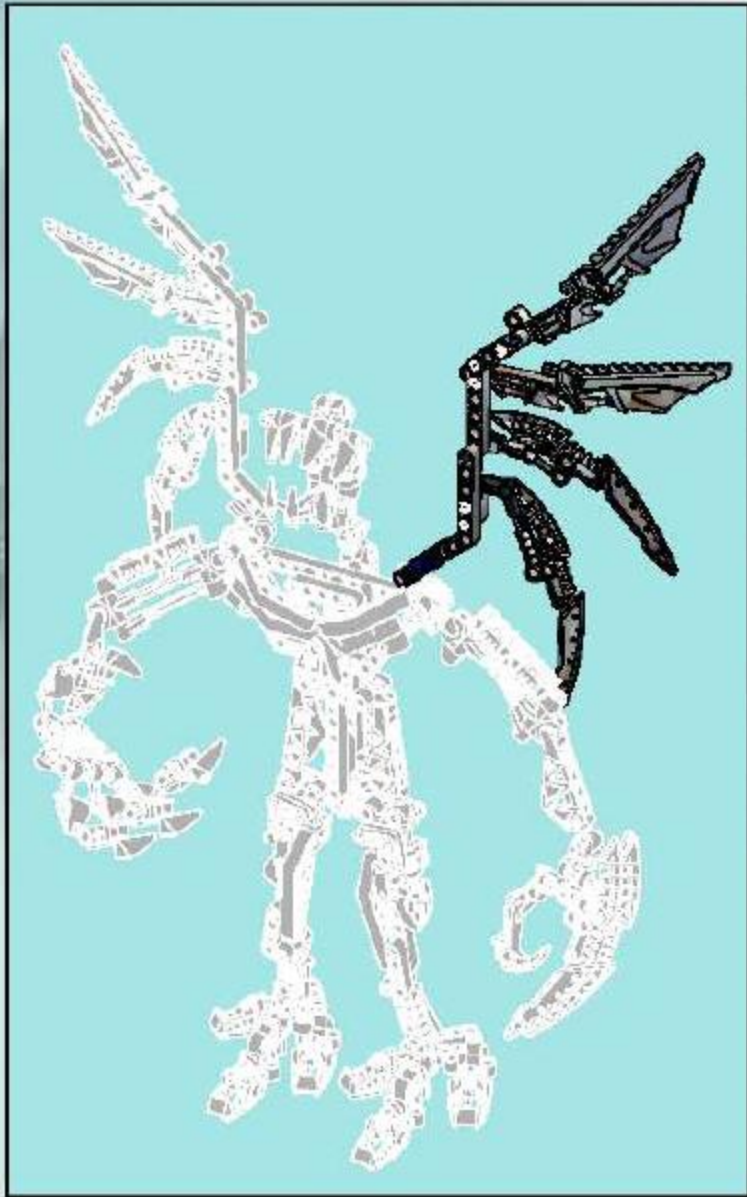

1

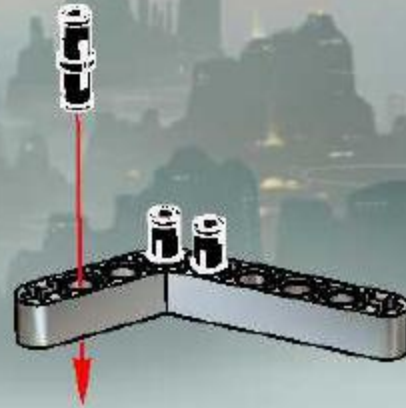

2

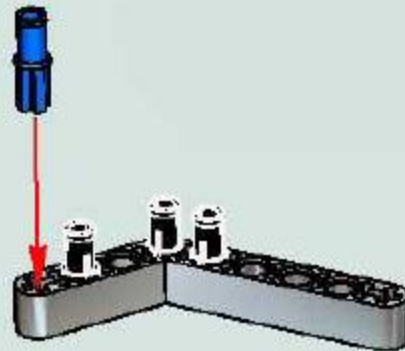





3

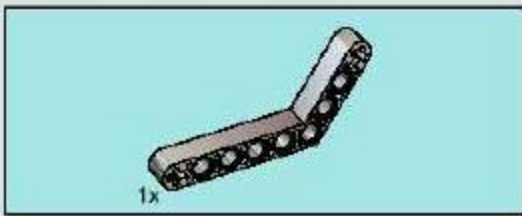
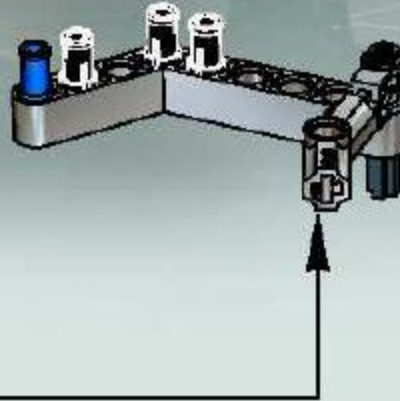
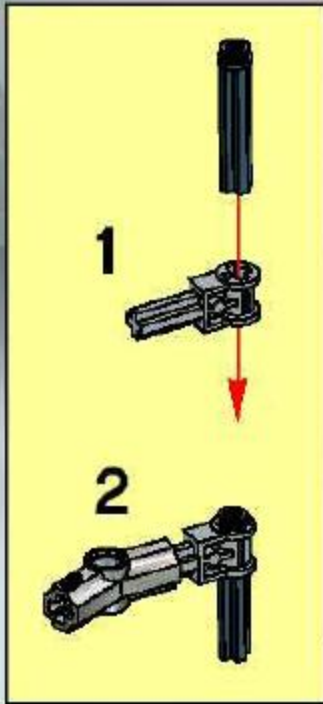

4

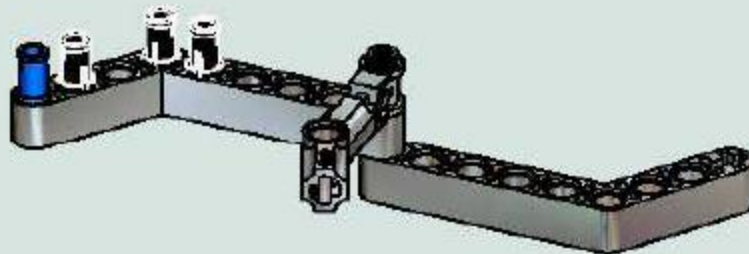



5

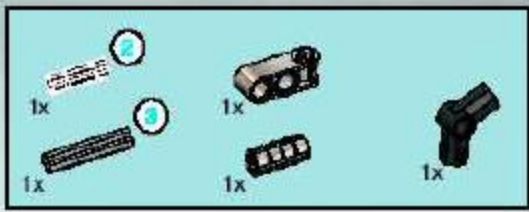
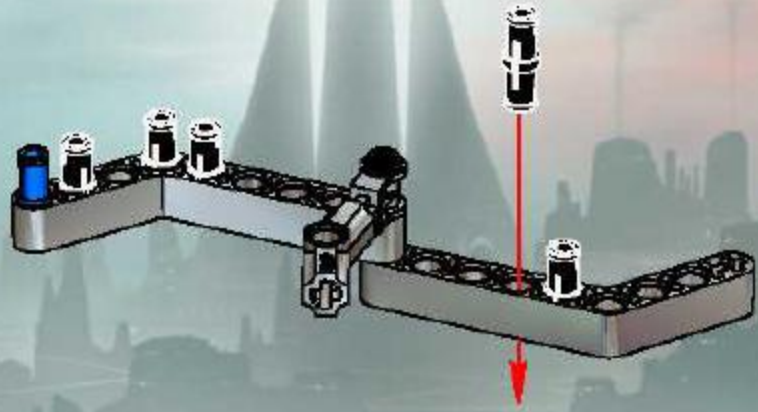

6

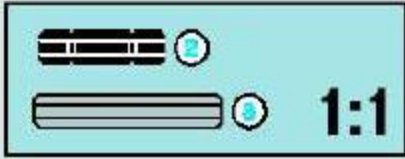
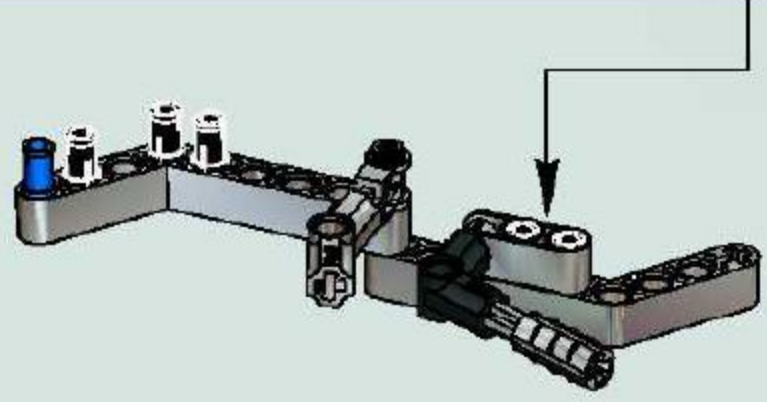
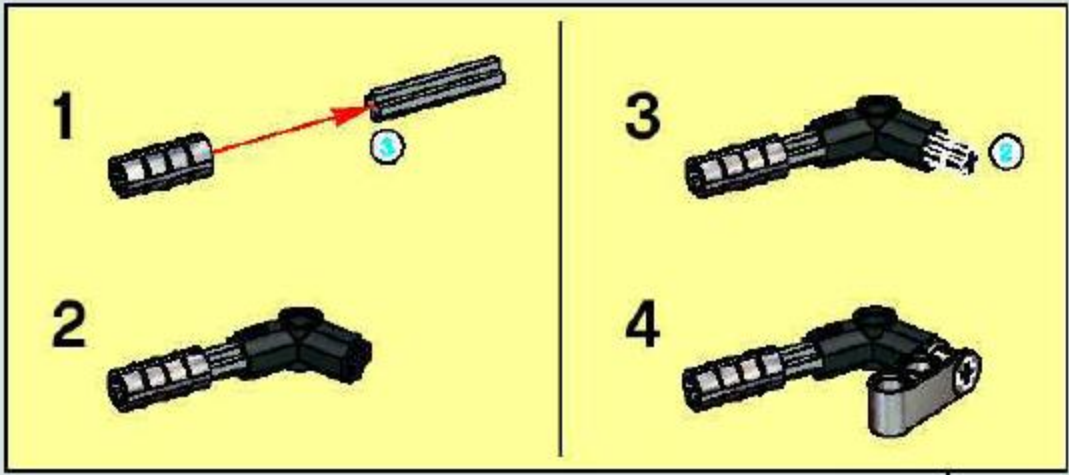



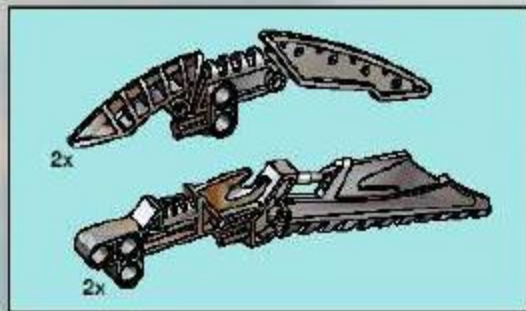

7

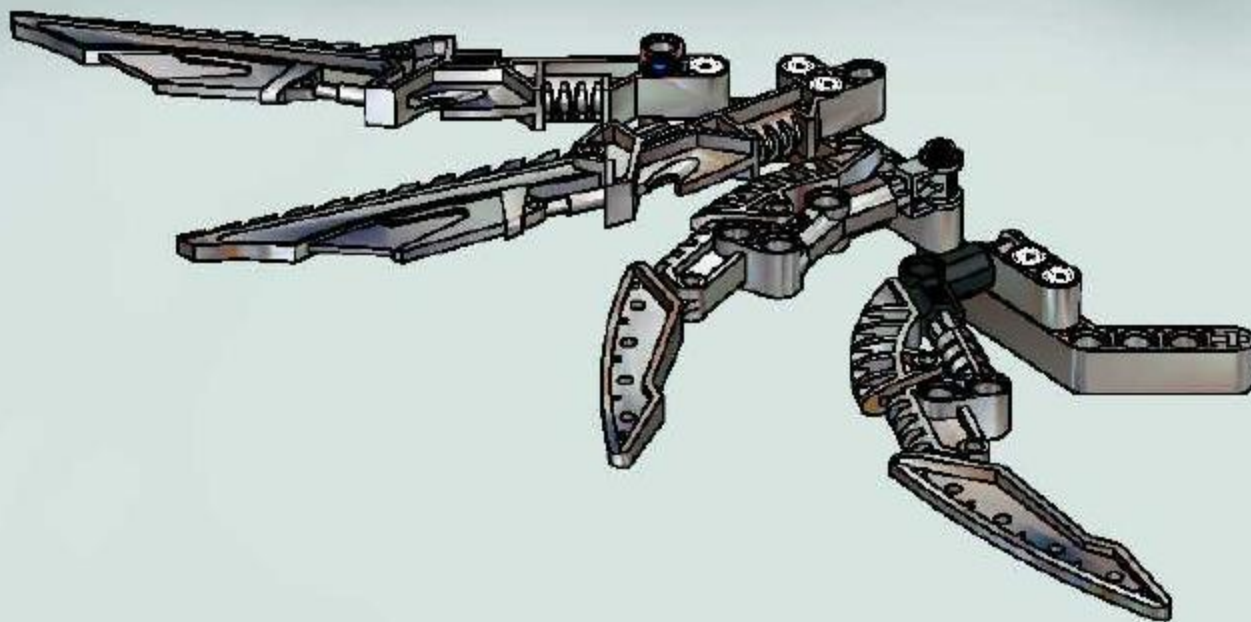



8

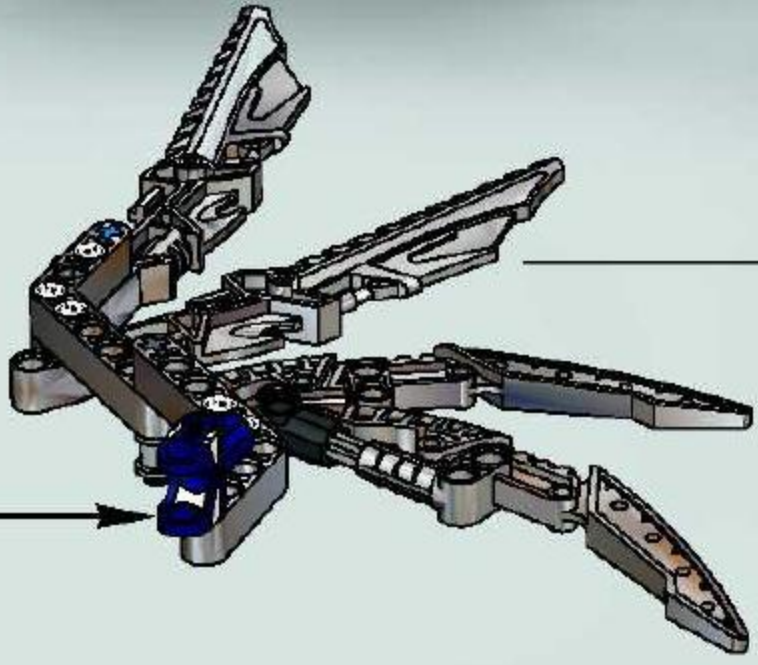
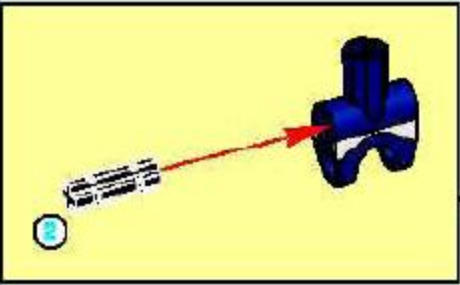



23

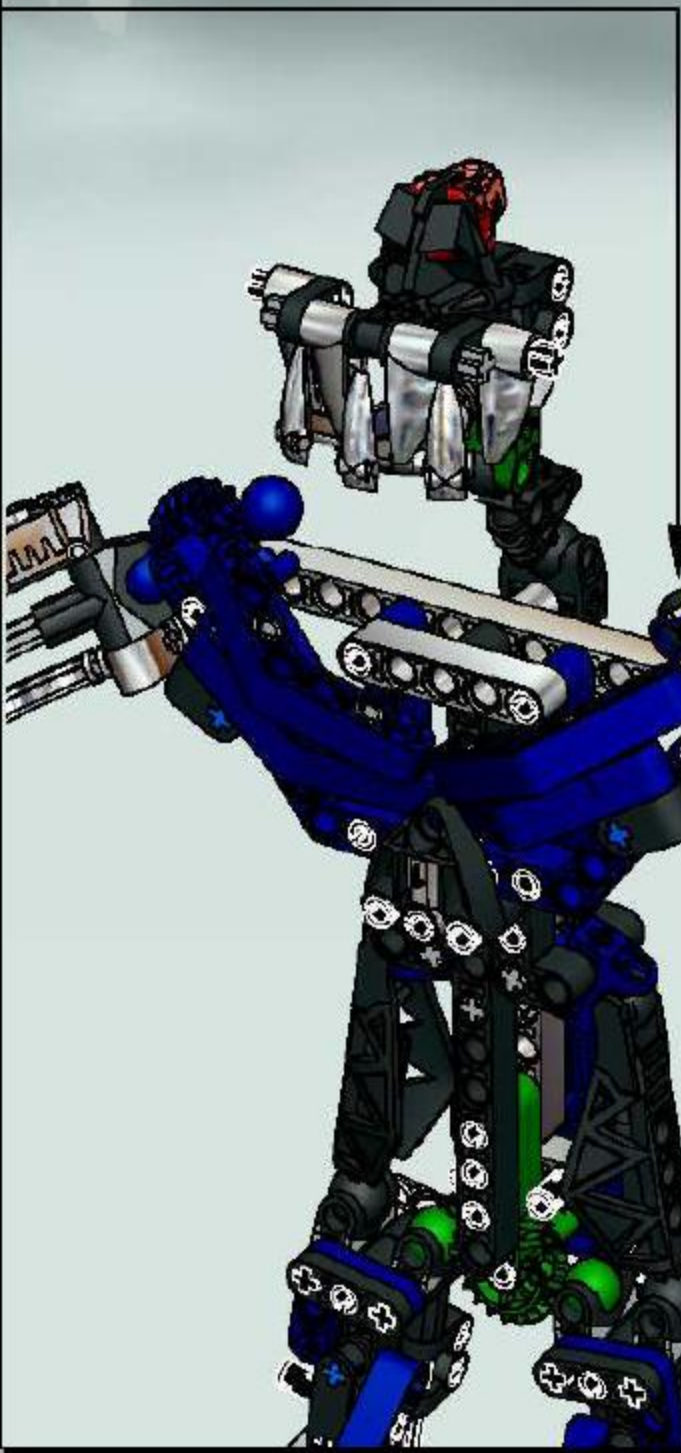

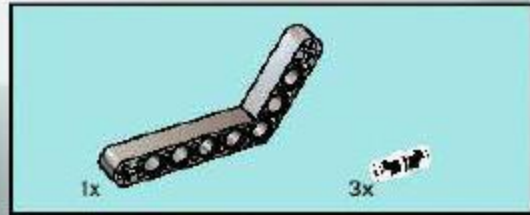
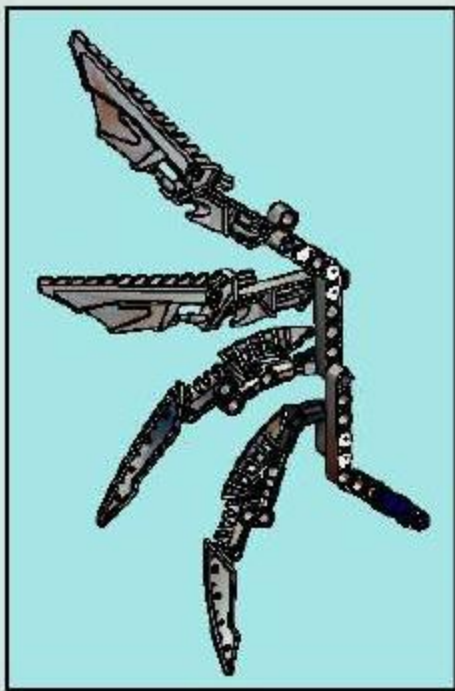
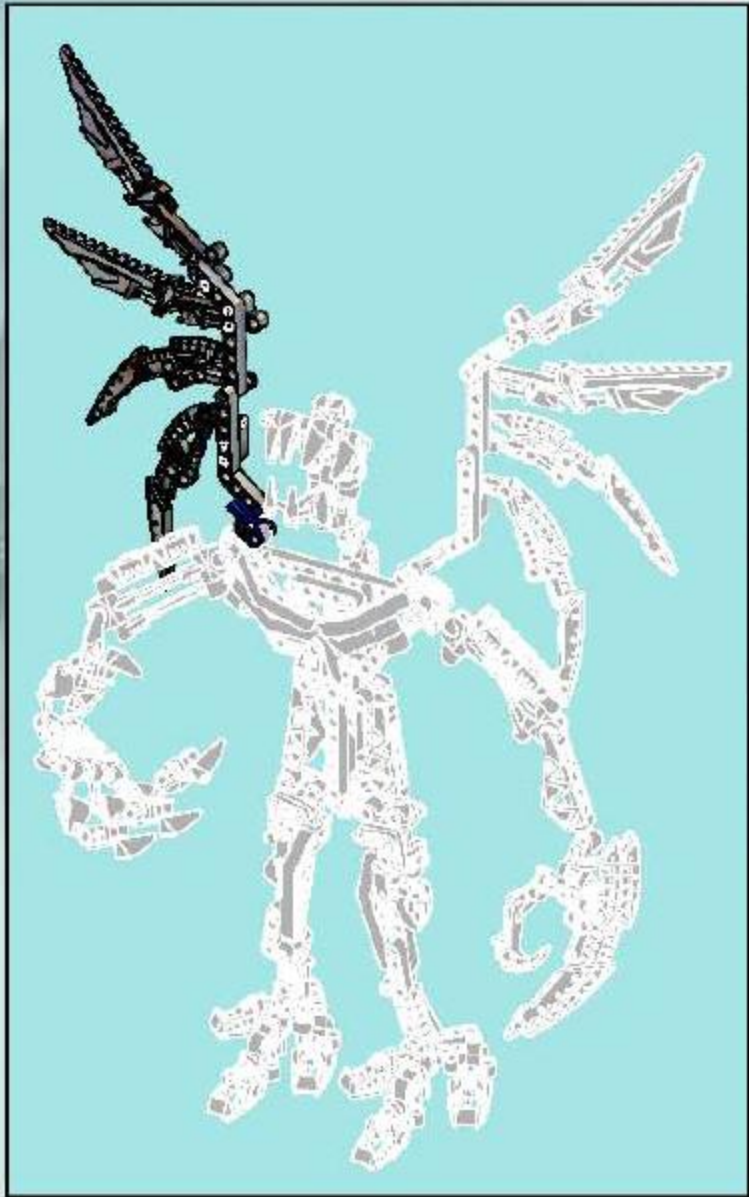

1

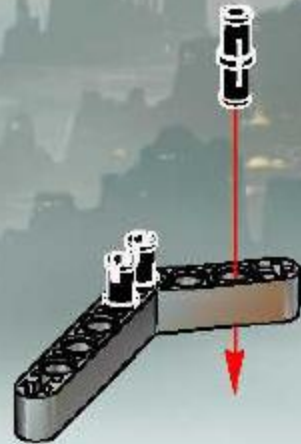

2

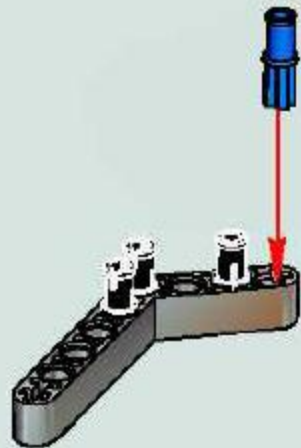





3

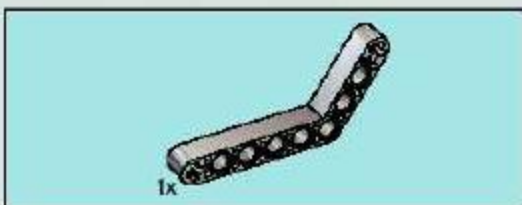
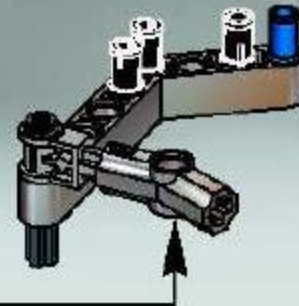
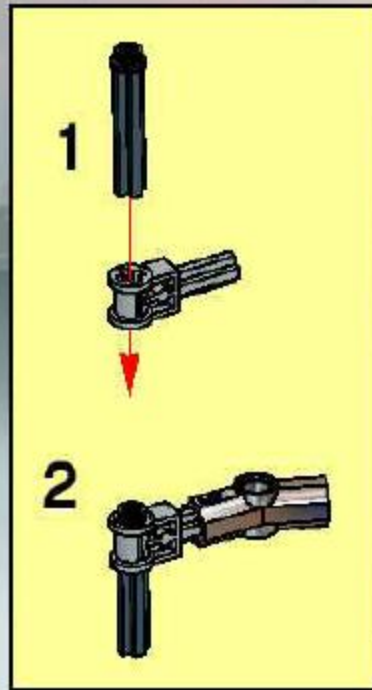

4

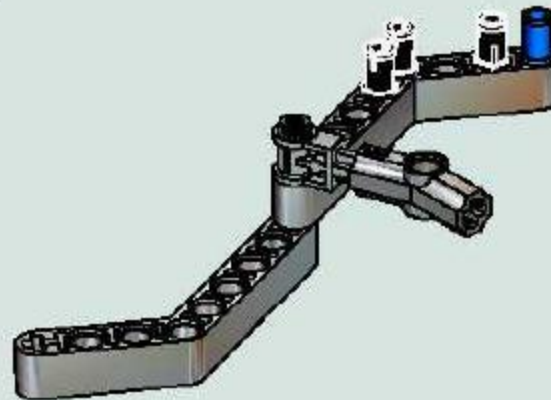



5

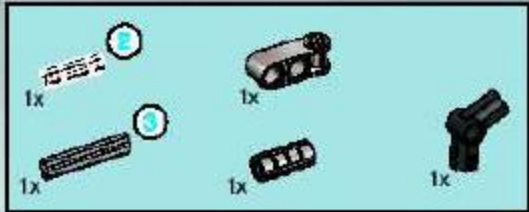
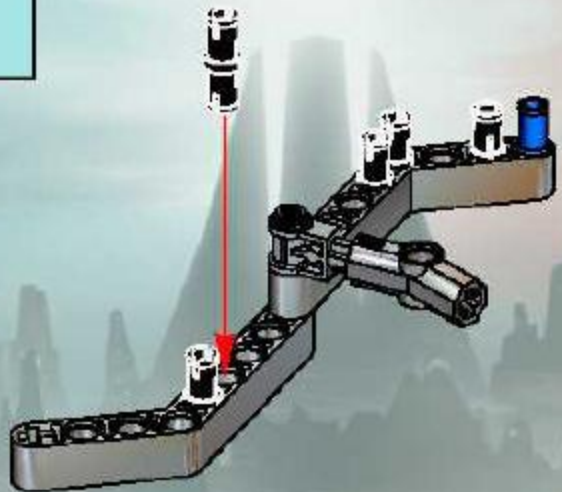

6

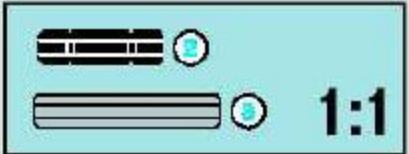
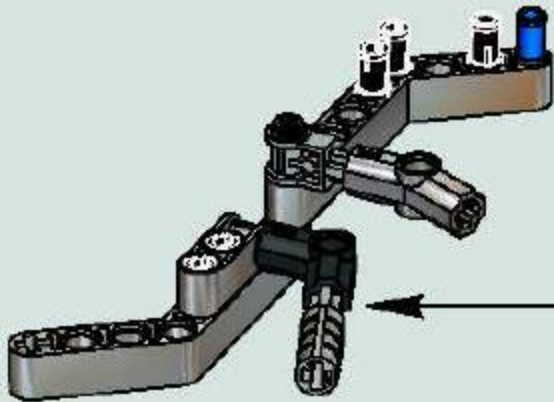
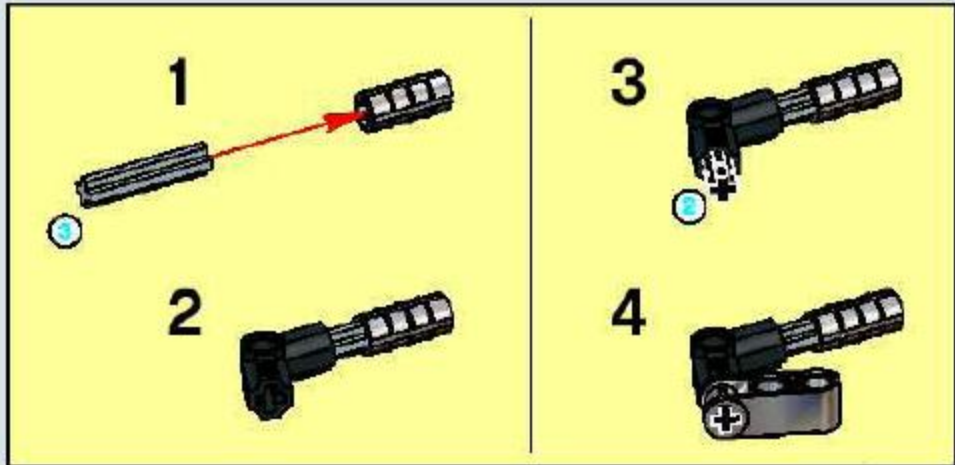



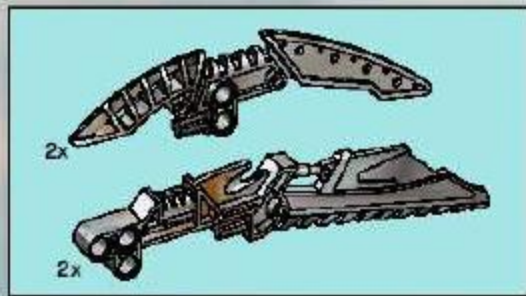

7

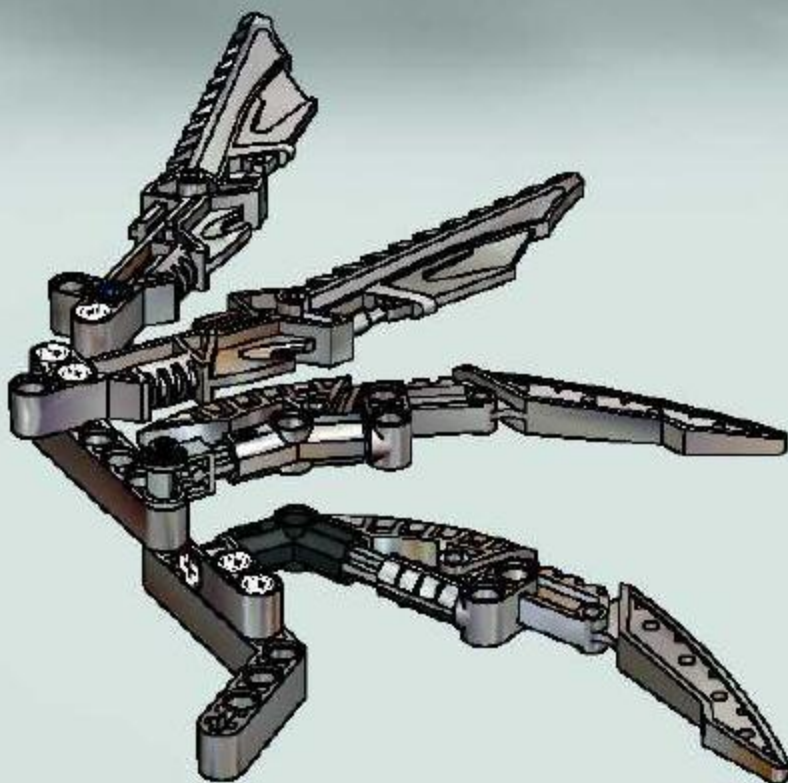



8

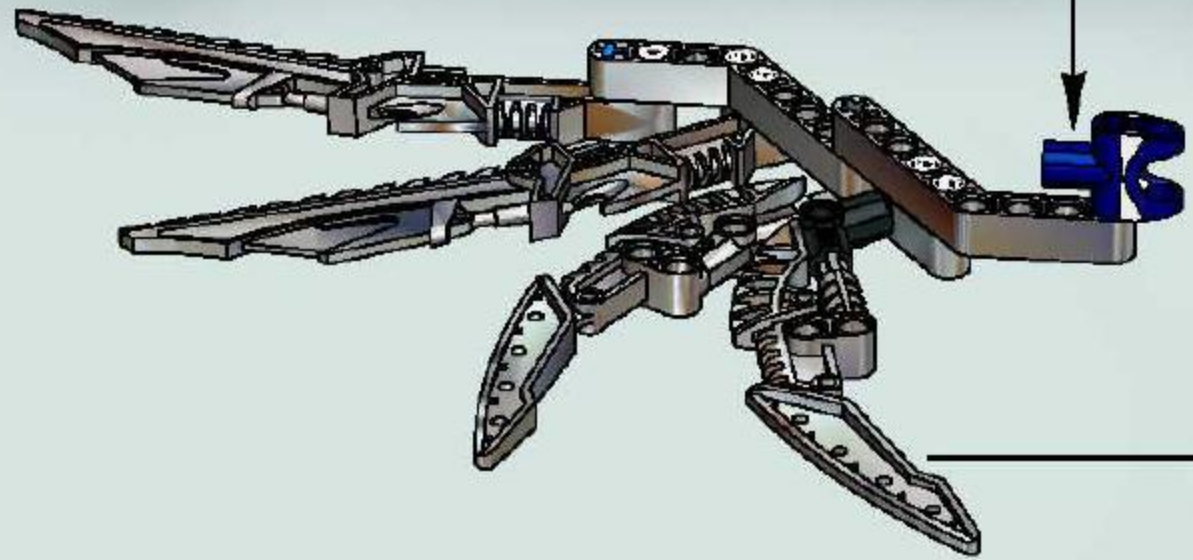
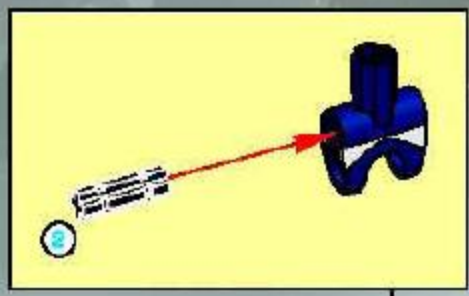



24

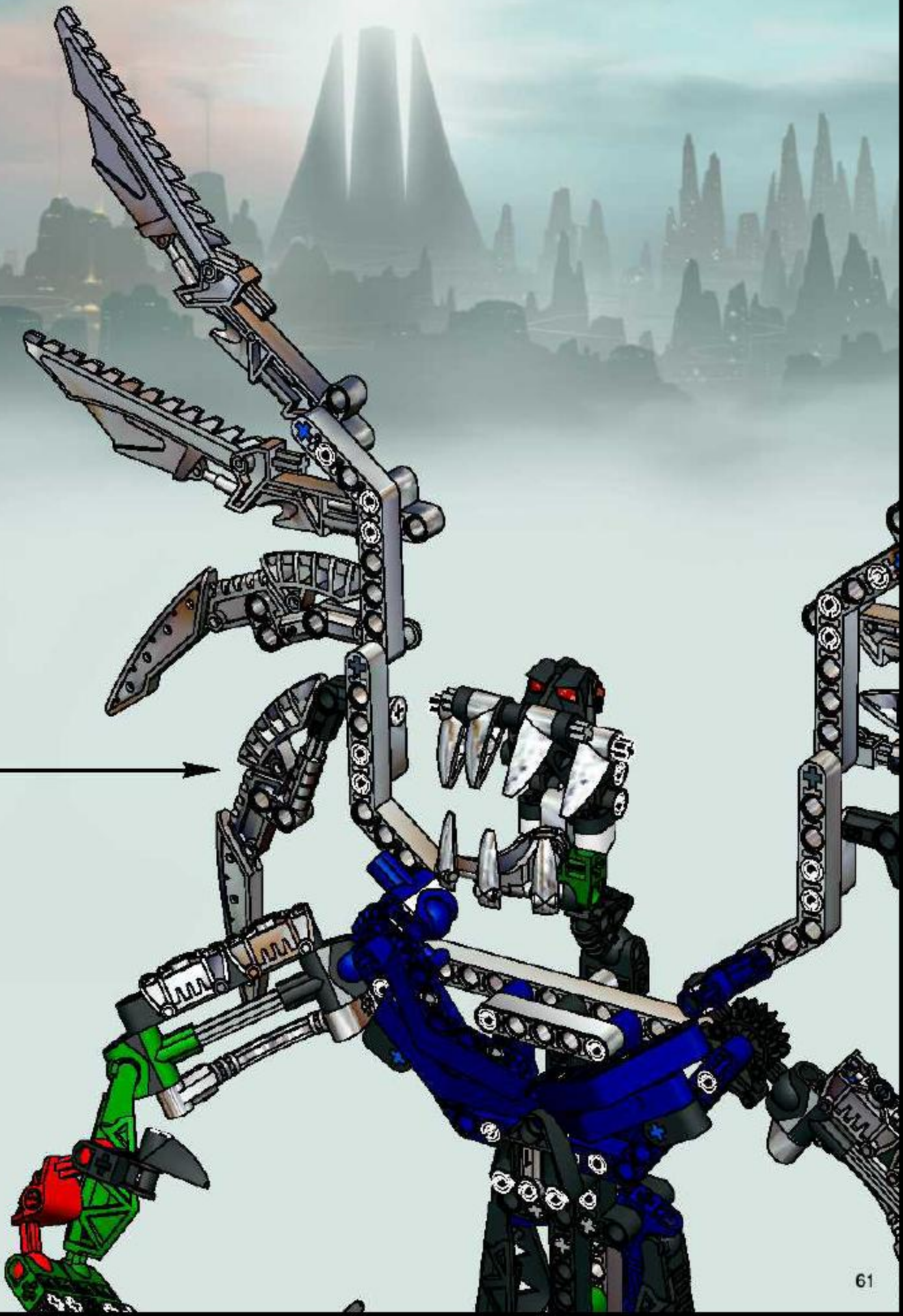







# BIONICLE

www.bionicle.com



VAHKI  
PUURAKH  
8614



VAHKI  
BORDAKH  
8615



VAHKI  
VORZAKH  
8616



VAHKI  
ZADAKH  
8617



VAHKI  
RORZAKH  
8618



VAHKI  
KEERAKH  
8619







# BIONICLE

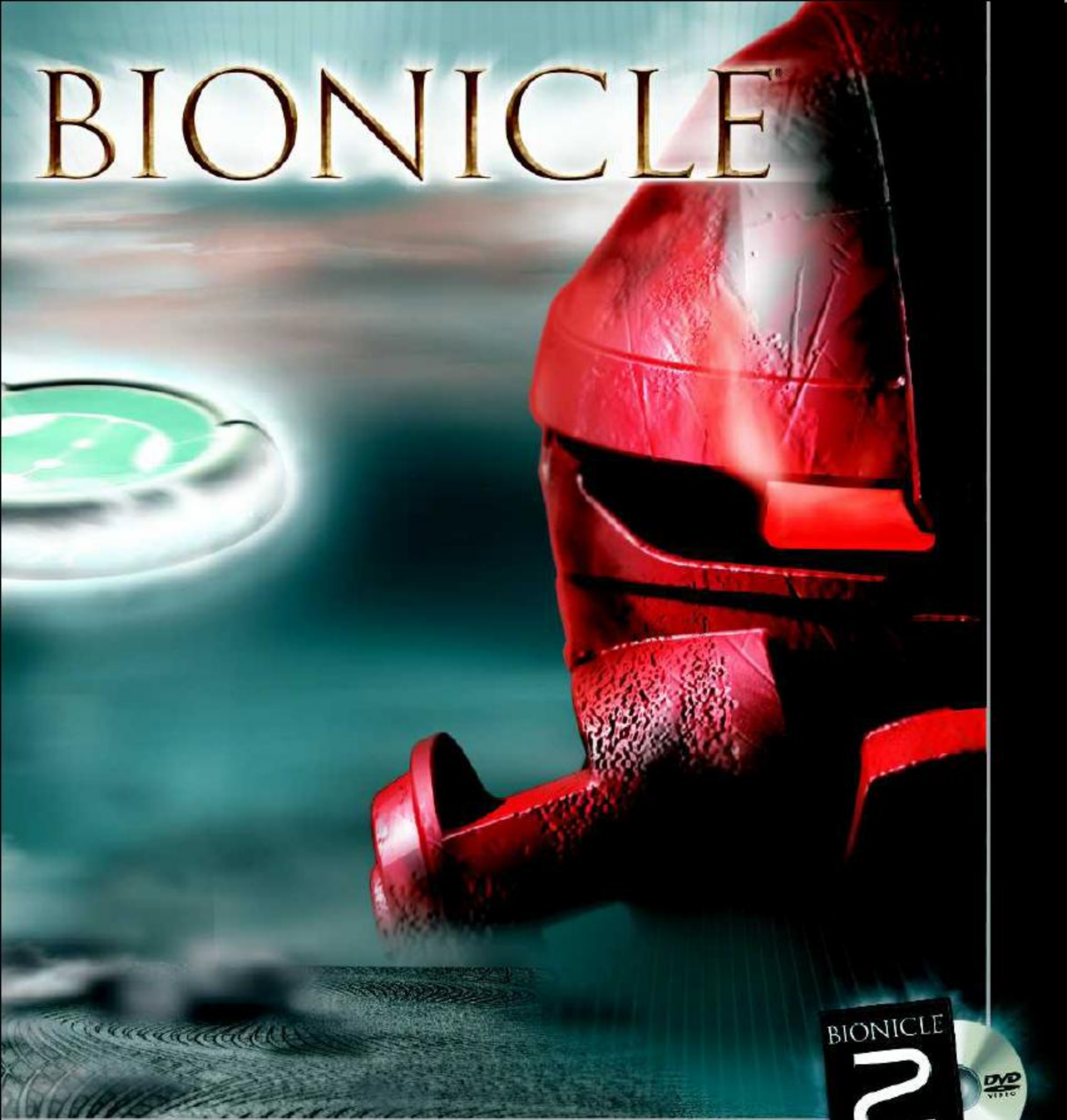

BIONICLE  
**2**  
LEGENDS OF  
METRU NUI







# LEGOLAND



[www.LEGOLAND.com](http://www.LEGOLAND.com)

LEGO, the LEGO logo, the brick configuration and LEGOLAND are trademarks of the LEGO Group.  
©2004 The LEGO Group.



**Win!**  
**Gagne!**  
**Gewinne!**  
**当たります**



#### WIN LEGO® PRODUCTS

We would like to know what you think about our new LEGO® product. If you could help us by answering a few questions you are in with a chance of winning an exciting LEGO prize. It will only take you about 3 minutes! Log on to the web address below for further instructions.



#### GAGNE DES PRODUITS LEGO®

Nous aimerions savoir ce que tu penses de ton nouveau produit LEGO®. Si tu veux bien nous aider en répondant à quelques questions, tu recevras peut-être bientôt un fantastique prix LEGO. Et cela ne te prendra que 3 minutes environ! Tu obtiendras davantage d'informations en visitant le site Internet indiqué ci-dessous.



#### GEWINNE LEGO® PRODUKTE

Wir sind sehr an deiner Meinung über dein neues LEGO® Produkt interessiert. Wenn du uns den Gefallen tust und ein paar Fragen beantwortest, kannst du einen tollen LEGO Preis gewinnen. Das Ganze dauert nur etwa 3 Minuten! Gehe einfach zu der unten angegebenen Webadresse - dort findest du weitere Informationen.



#### Estimado usuario LEGO®

Al contestar algunas preguntas en inglés, francés, alemán o japonés, en el sitio [www.acnielsen.aim.dk/lego](http://www.acnielsen.aim.dk/lego), podrás participar en el sorteo de algunos valiosos premios LEGO®.



#### Caro Consumidor da LEGO®

Ao responder a algumas perguntas em Inglês, Francês, Alemão ou Japonês no endereço [www.acnielsen.aim.dk/lego](http://www.acnielsen.aim.dk/lego) irá participar num concurso para ganhar valiosos prémios da LEGO®.



#### Kedves Ifjú LEGO® Vésérlő

Ha ellátogat a [www.acnielsen.aim.dk/lego](http://www.acnielsen.aim.dk/lego) honlapra és ott angol, francia, német vagy japán nyelven megválaszolsz néhány kérdést, akkor részt veszel egy versenyben, amelyben értékes LEGO® díjakat nyerhetsz.



#### 抽選でレゴ®製品が当たります

私たちは、皆さんが買い求めたレゴ®製品についてどんな感想をお持ちか、知りたいと思っています。質問に答えて、楽しいレゴ®製品の抽選に応募しませんか。アンケートの回答には、ほんの少しの労いしかかかりません! 詳しくは、以下のウェブアドレスまでアクセスしてください。

[www.acnielsen.aim.dk/LEGO](http://www.acnielsen.aim.dk/LEGO)





BIONICLE<sup>®</sup>

# 2

LEGENDS OF  
METRU NUI

