



9484



WARNING: CHOKING HAZARD.
Toy contains small parts and a small ball.
Not for children under 3 years.

1

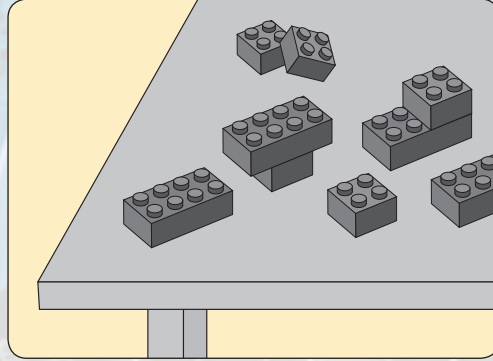
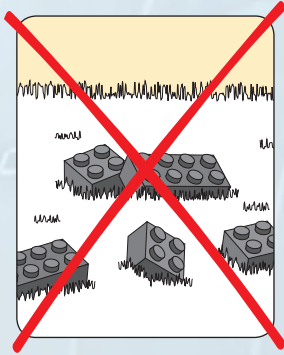

2



AVERTISSEMENT : RISQUE D'ÉTOUFFEMENT.
 Le jouet contient des petites pièces ainsi qu'une petite boule.
 Il ne convient pas aux enfants de moins de 3 ans.



ADVERTENCIA: PELIGRO DE ASFIXIA.
 Juguete que contiene partes pequeñas y una pelota pequeña.
 No recomendado para niños menores de 3 años.

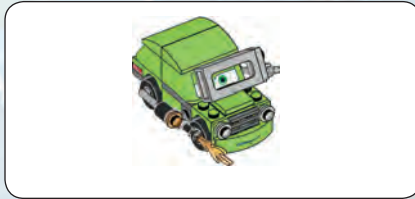
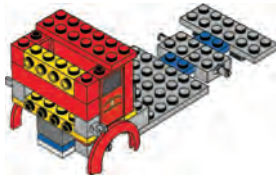

1

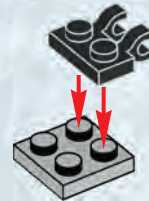

3

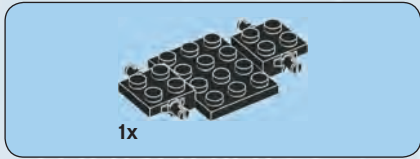

2



4

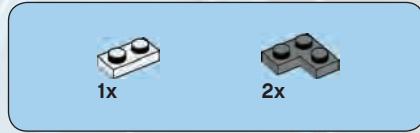

3





4

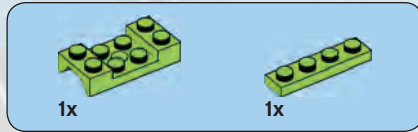

5

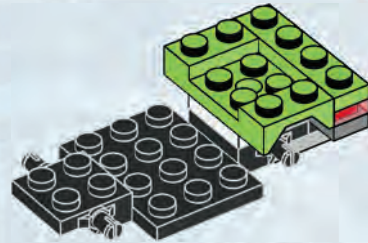

5

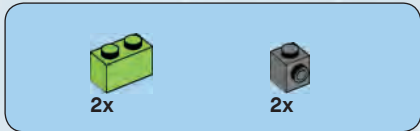

6

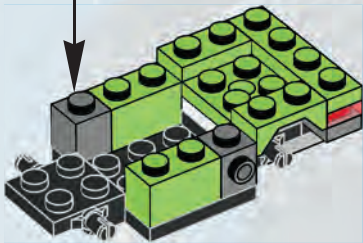

7

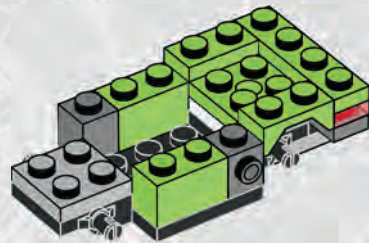



8

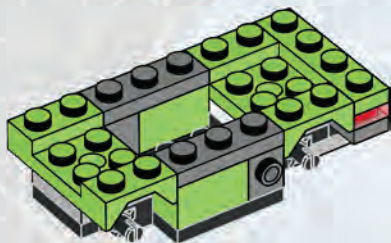

9

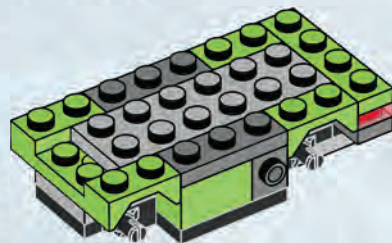



10

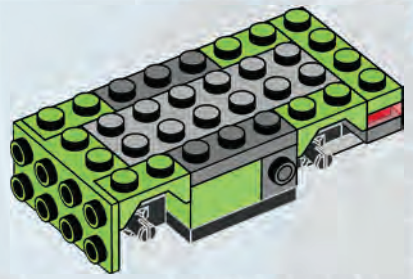

11

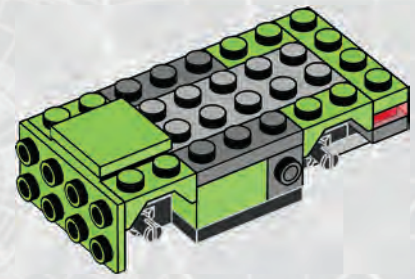



2x



1x

12

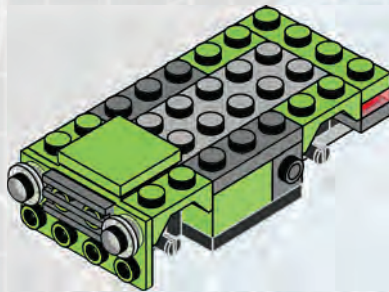

1x

13

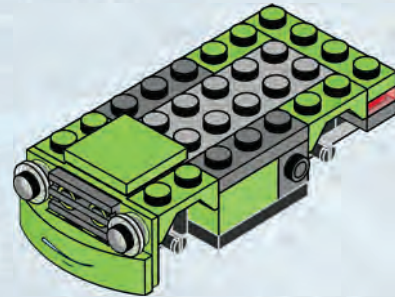

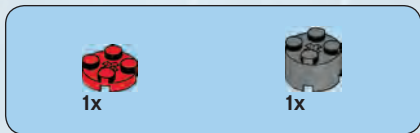

14

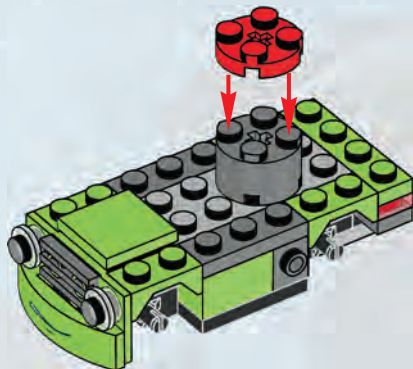

10

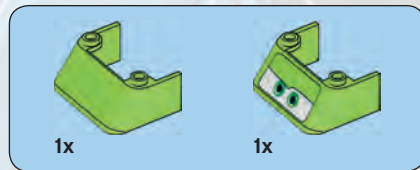

15

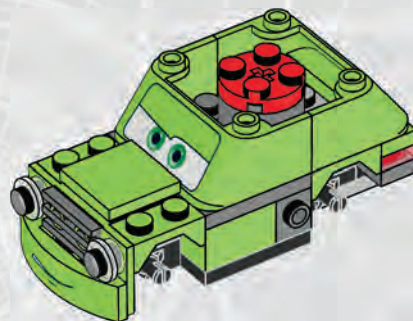



2x

16

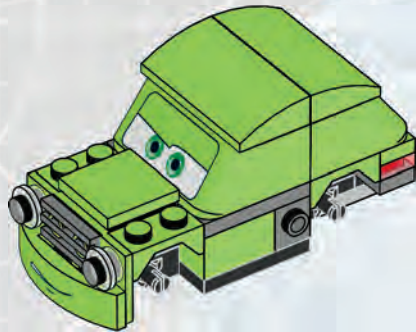

4x



4x

17

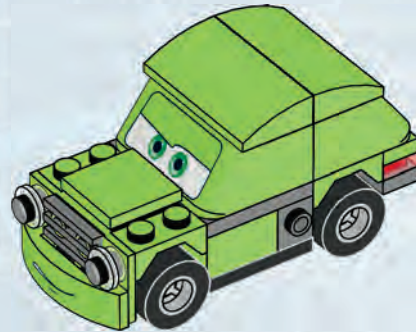

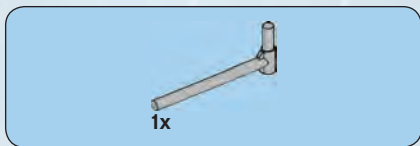

18

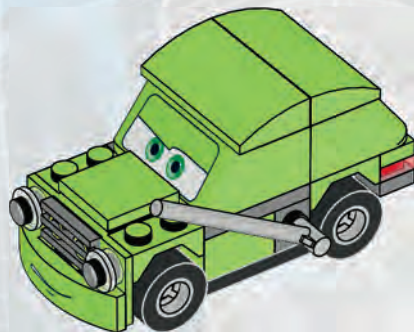

12



19

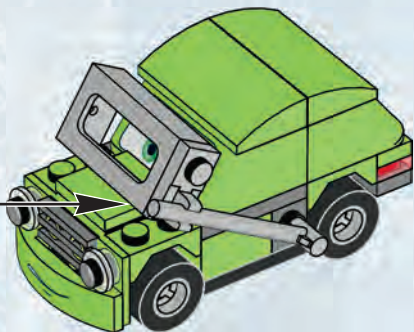
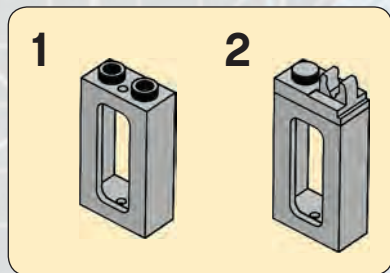

point 2 target acquired



20

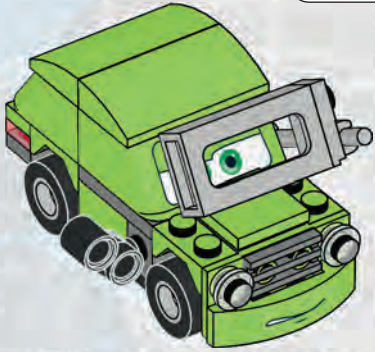



21

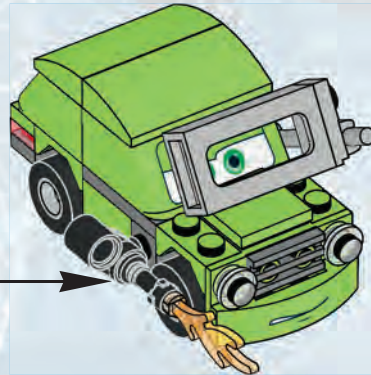

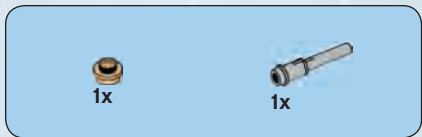

22

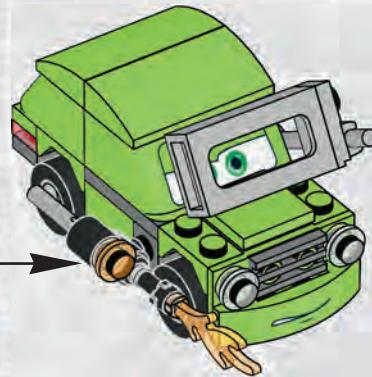
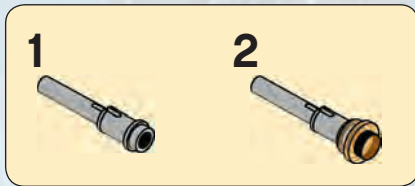

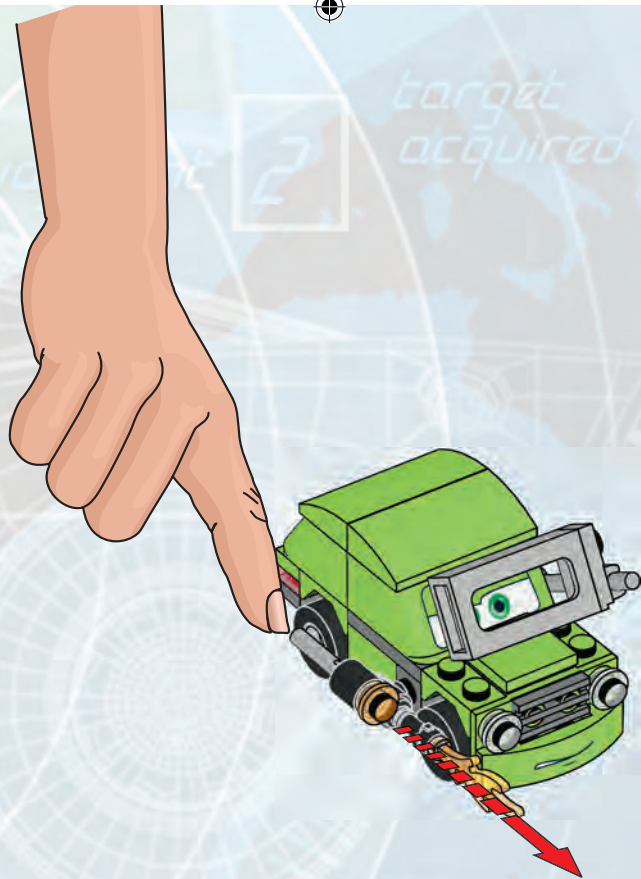

target
acquired



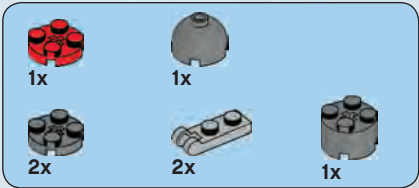
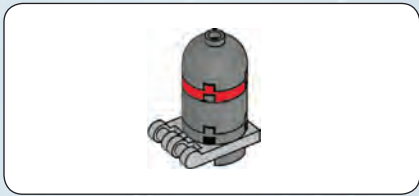

23

1



2

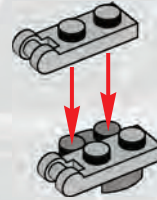

3



4

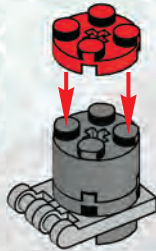

5

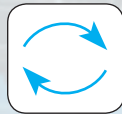
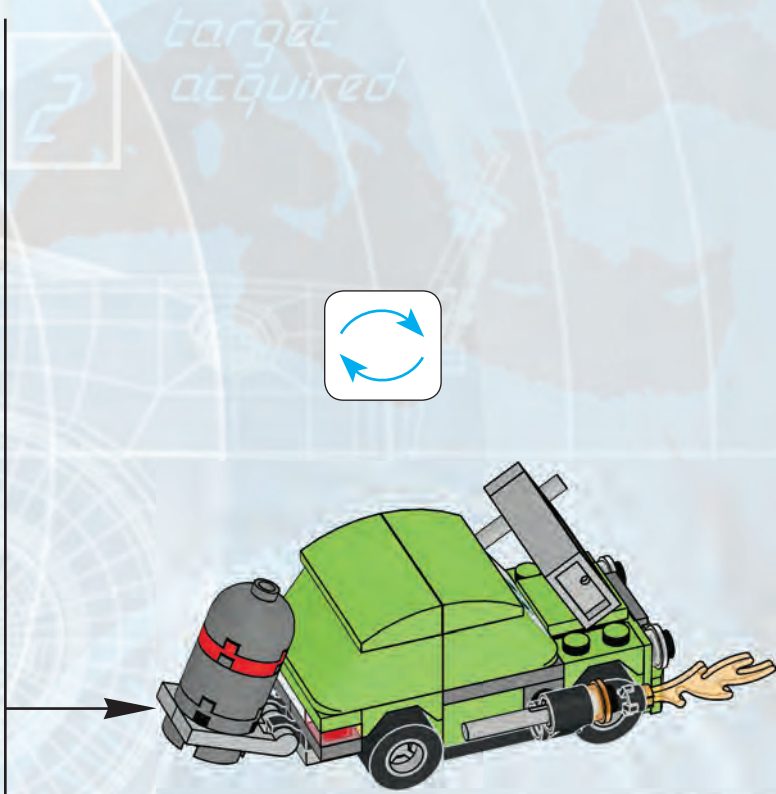
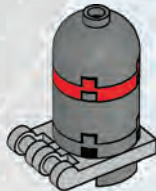

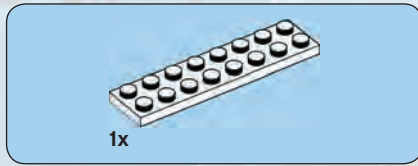
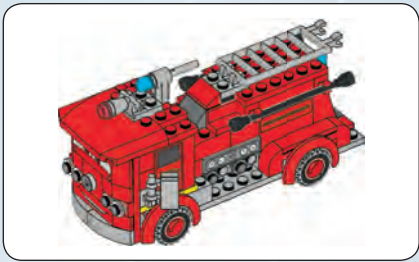

1



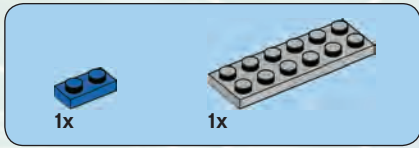

2

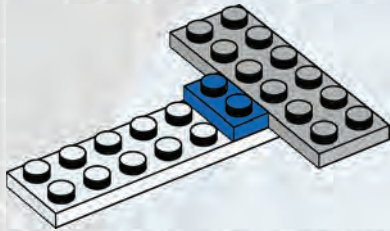

3

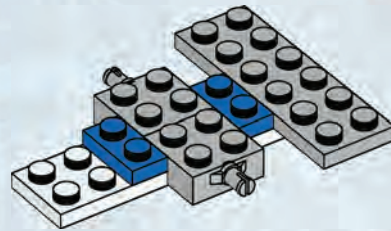



4

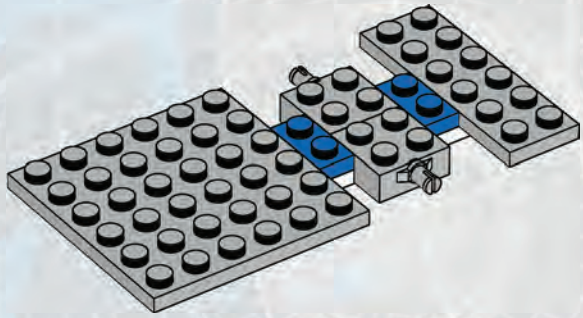

22

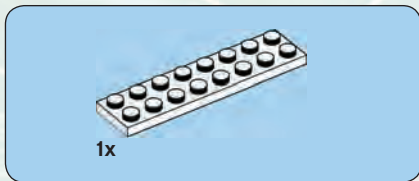

5

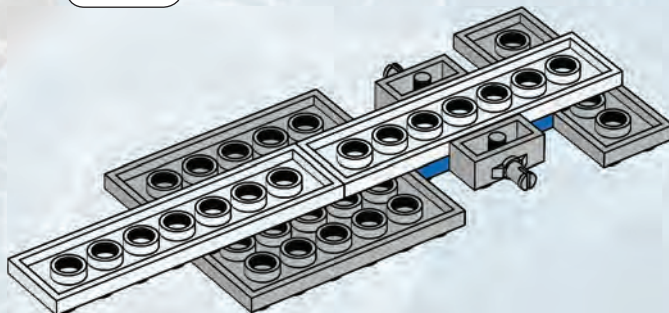
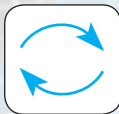



6

Waypoint

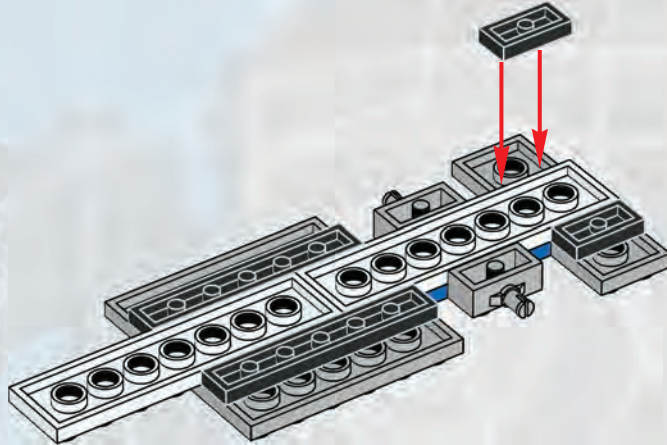

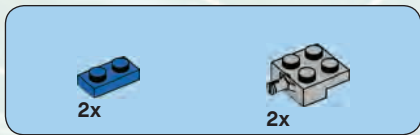

7

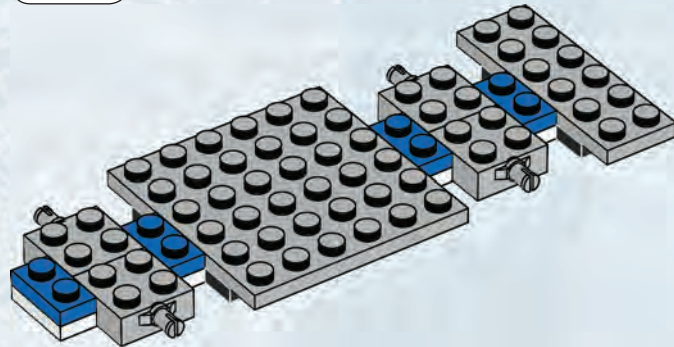
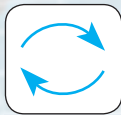



8

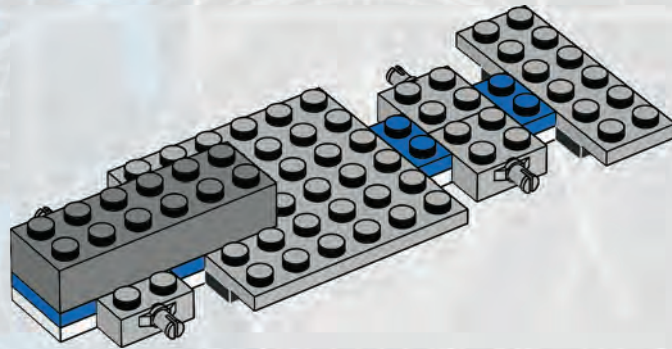

26

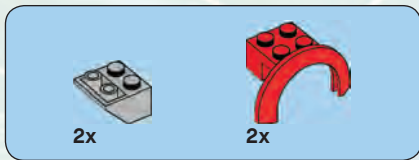

9

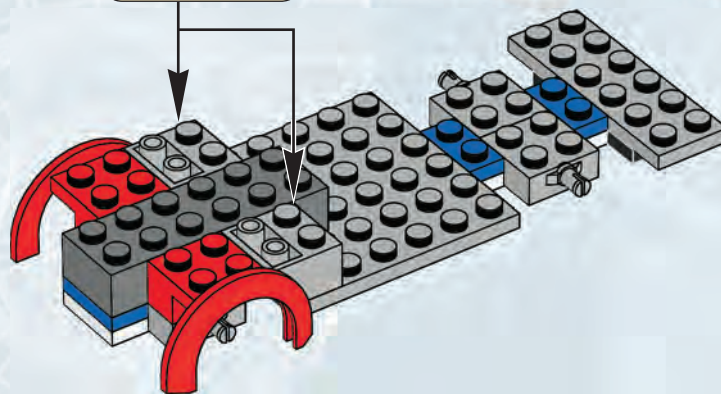

point 2
target acquired

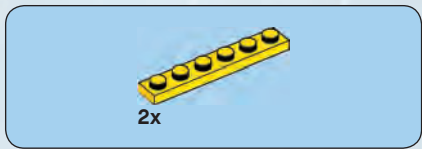

10

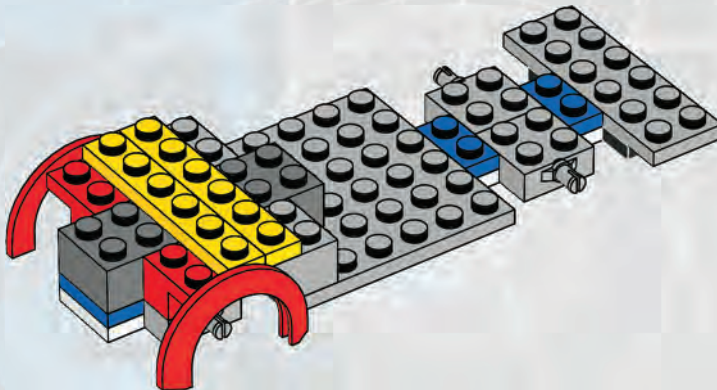

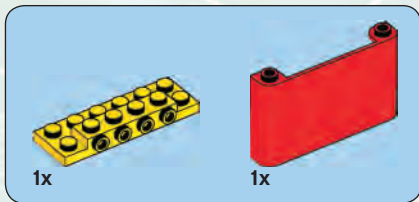

11

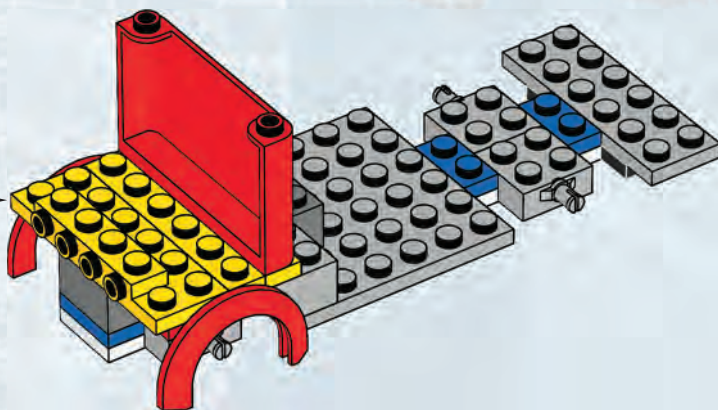
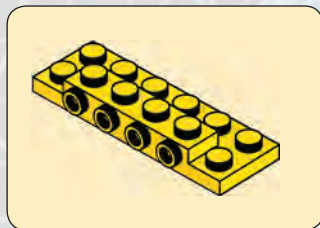

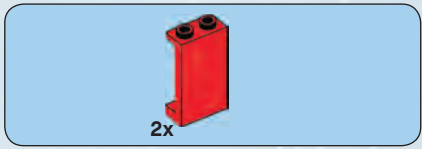

12

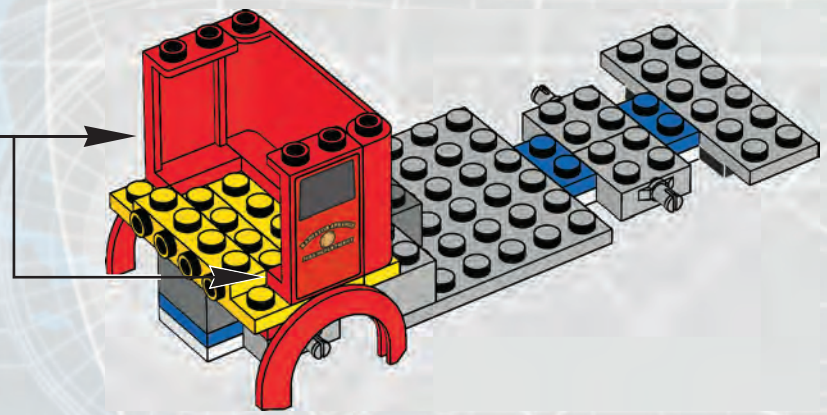
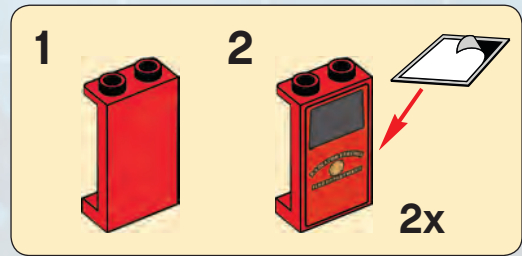



13

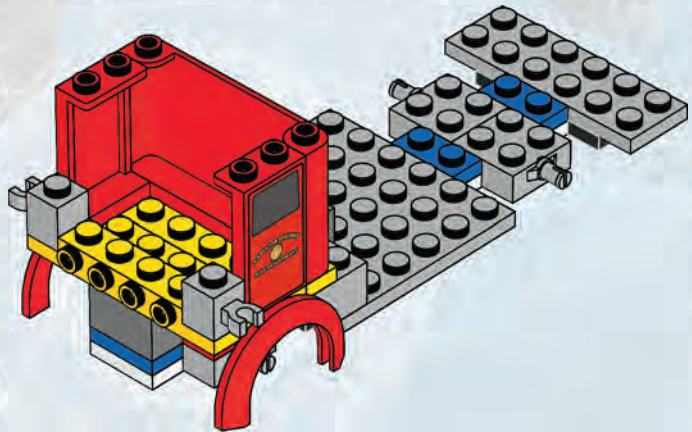

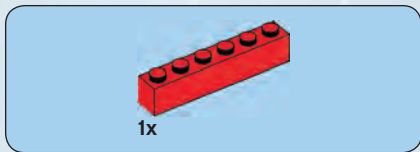

14

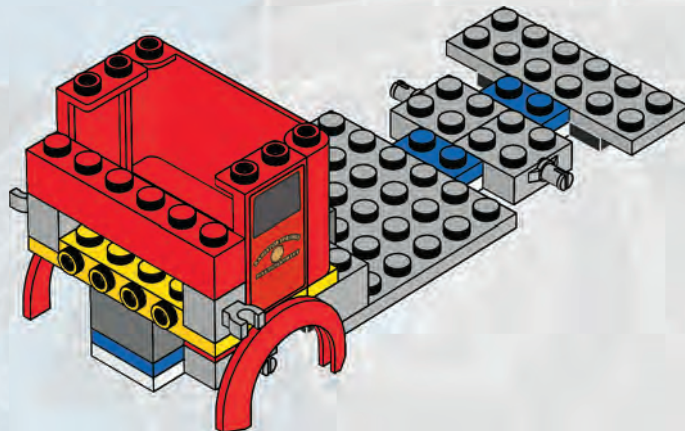

32



2x



1x

15

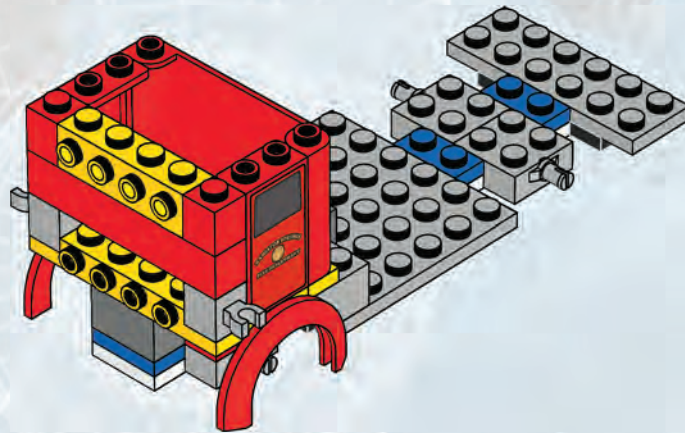



16

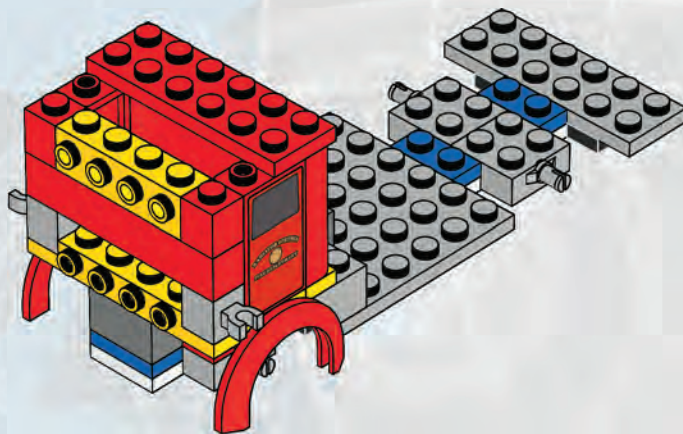

34

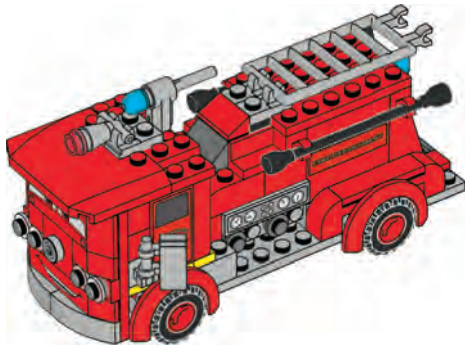

2x



1x

17

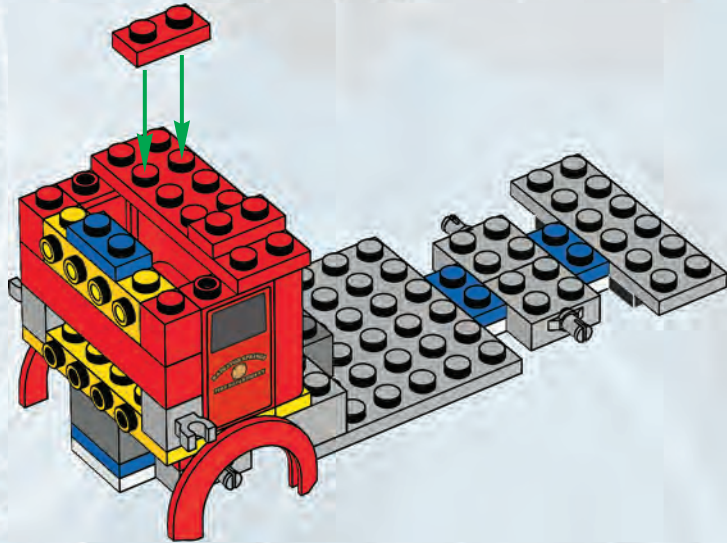

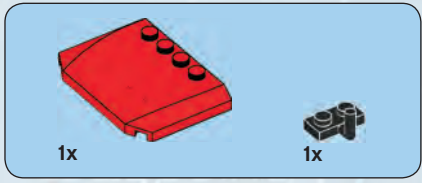

18

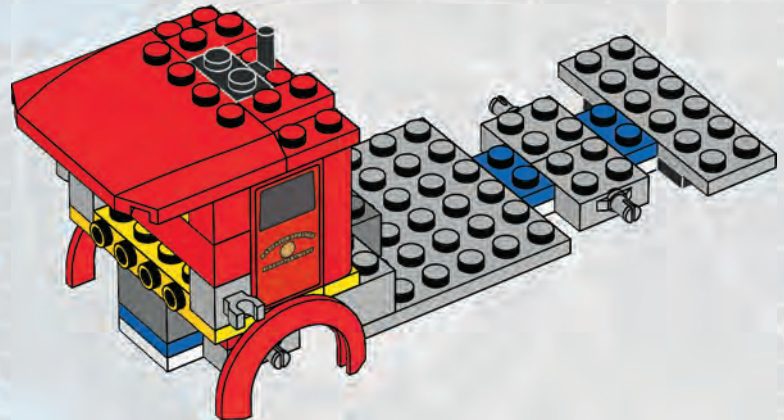



2x

19

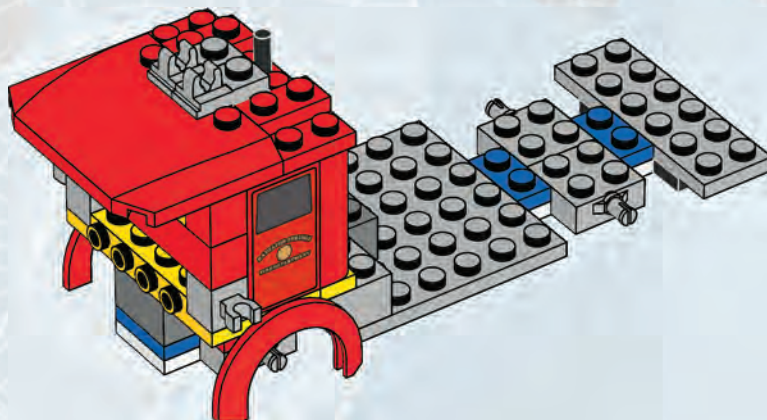

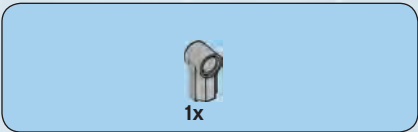

20

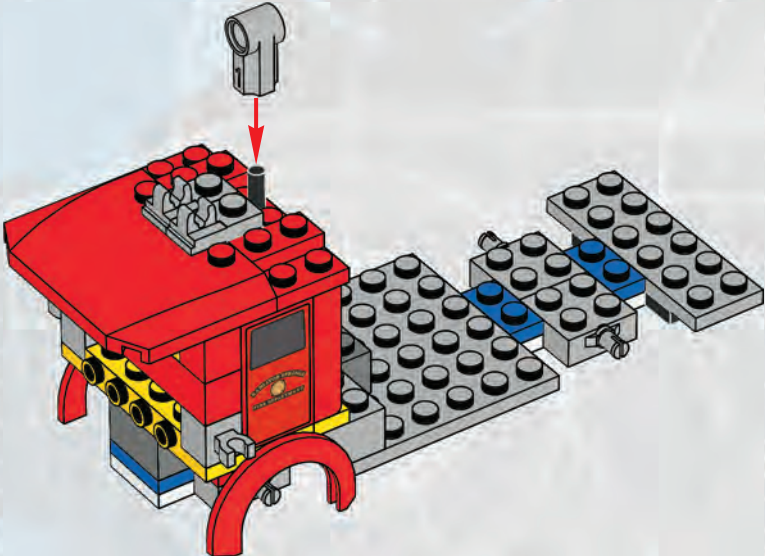

1x

1x

1x

21

1



2

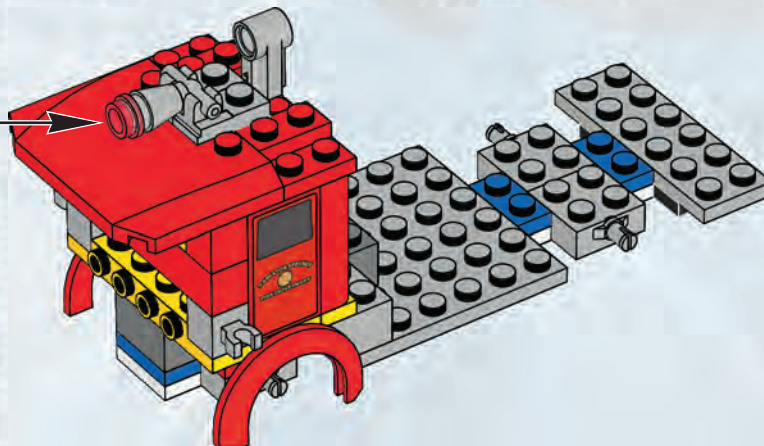



22

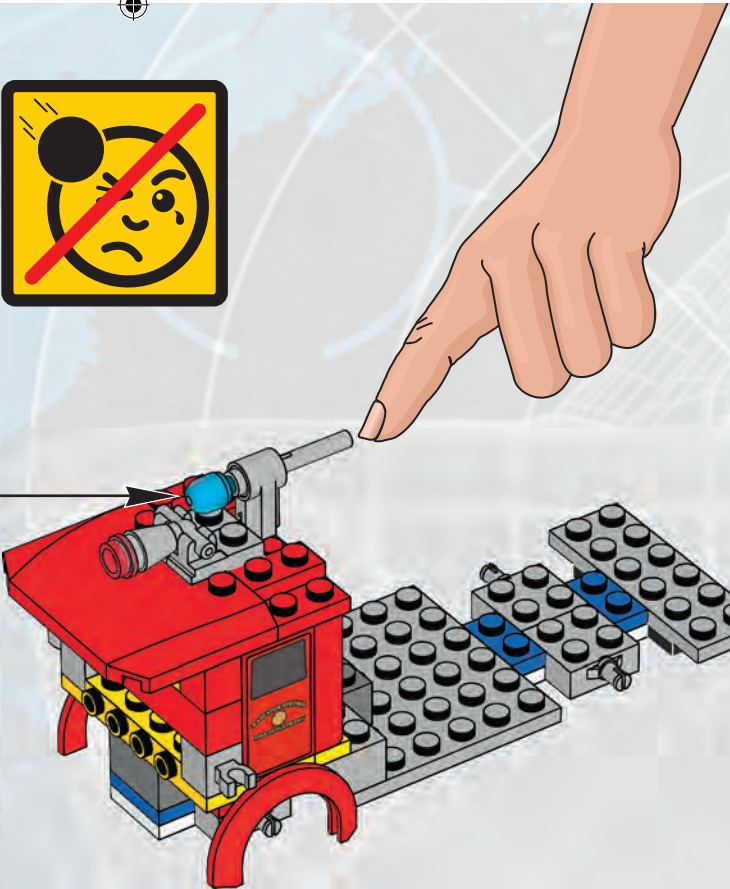
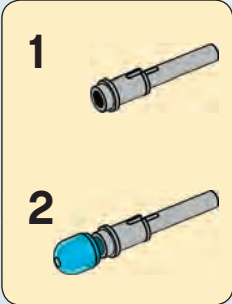

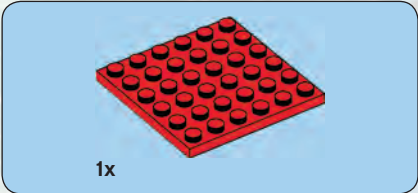
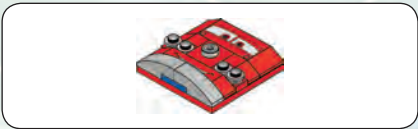

1x

1

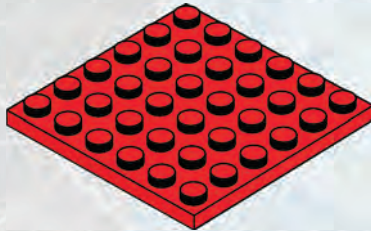

1x

1x

2





3

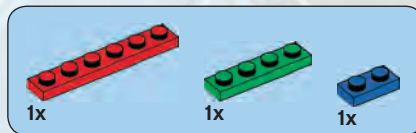
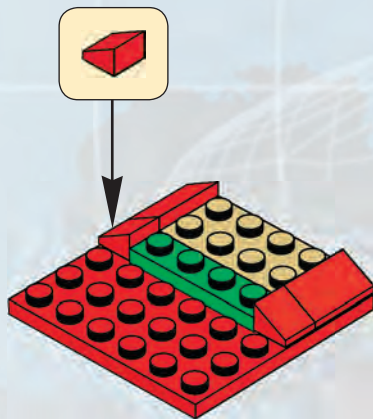

4

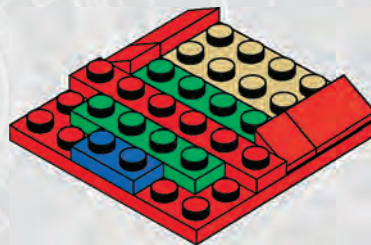

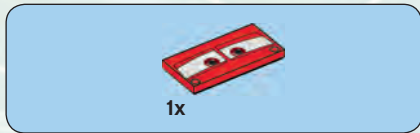

5

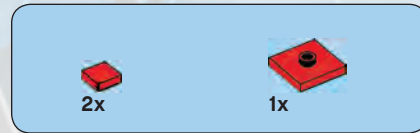
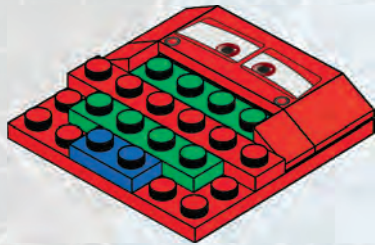

6

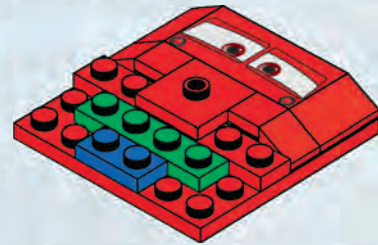

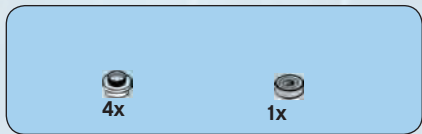

7 *waypoint*

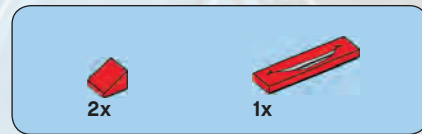
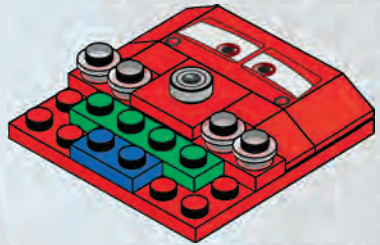

8

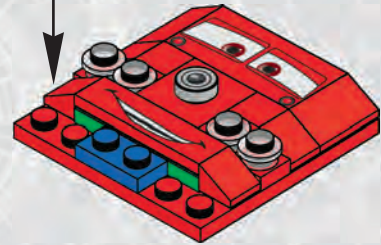
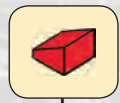

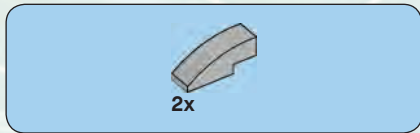

9

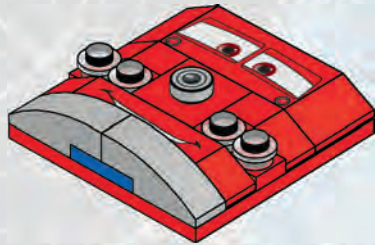

23

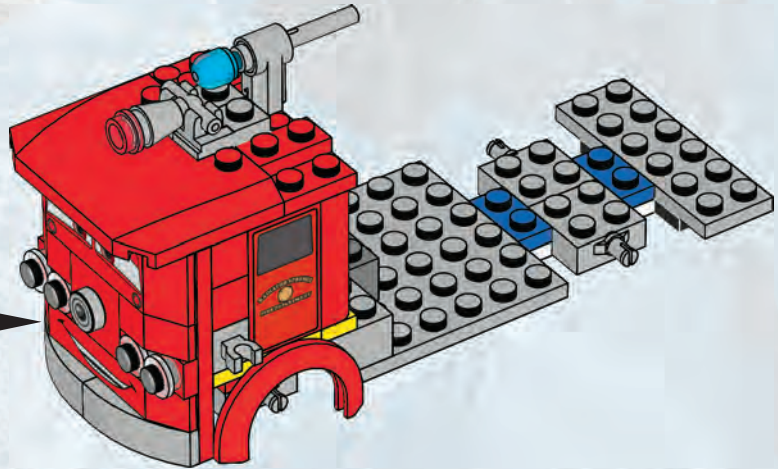

target
acquired

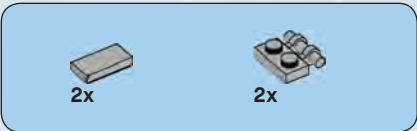

24

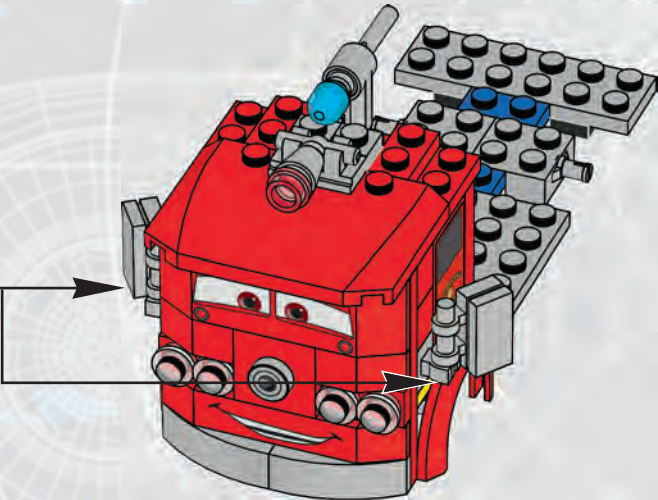
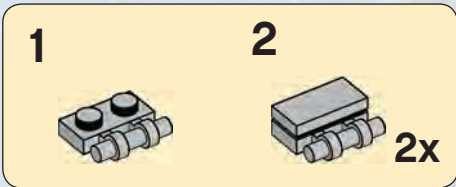

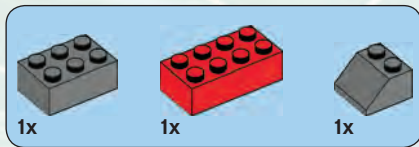

25

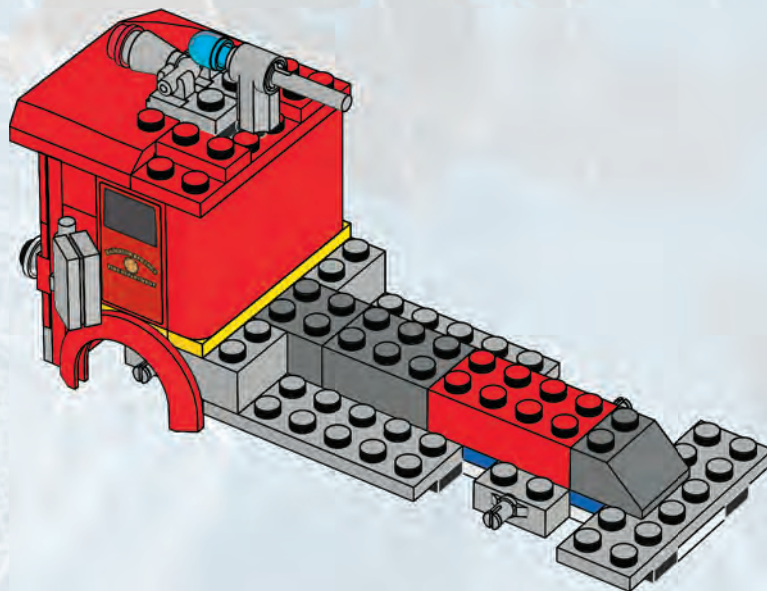
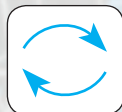



2x



1x

26

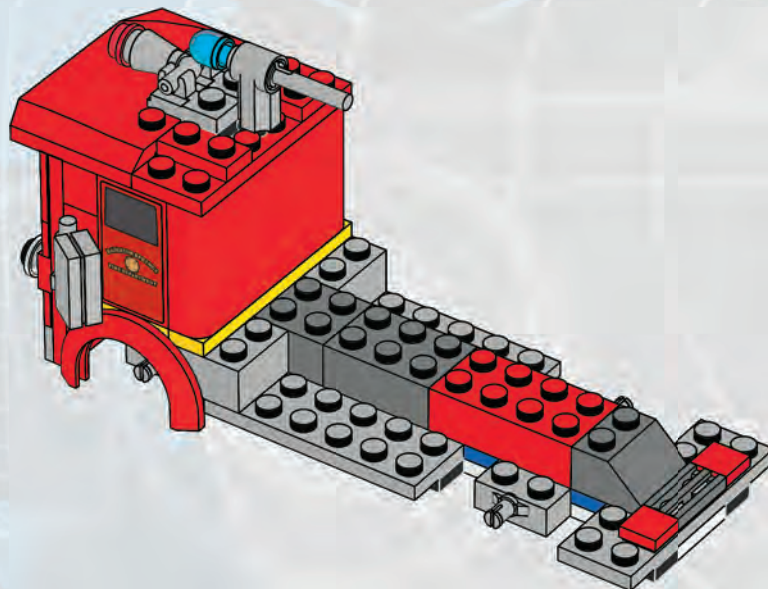

48

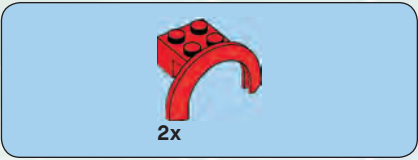

27

point 2
target acquired

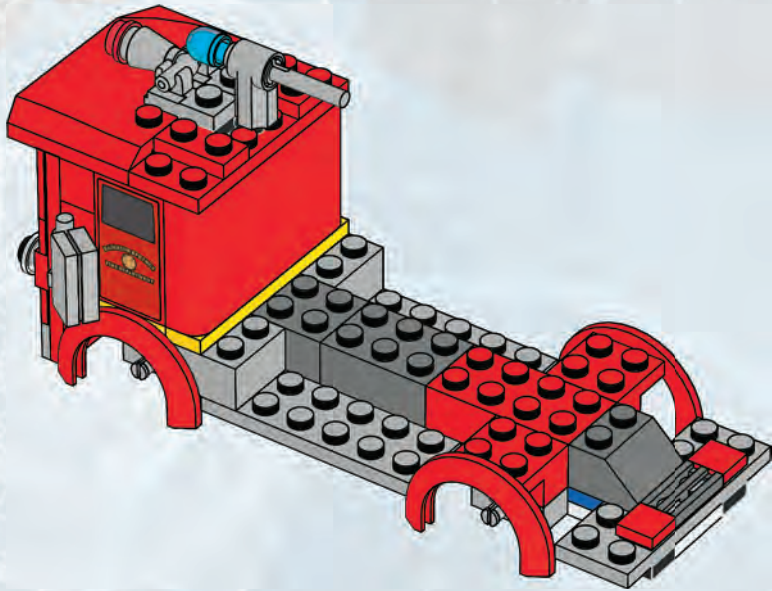



28

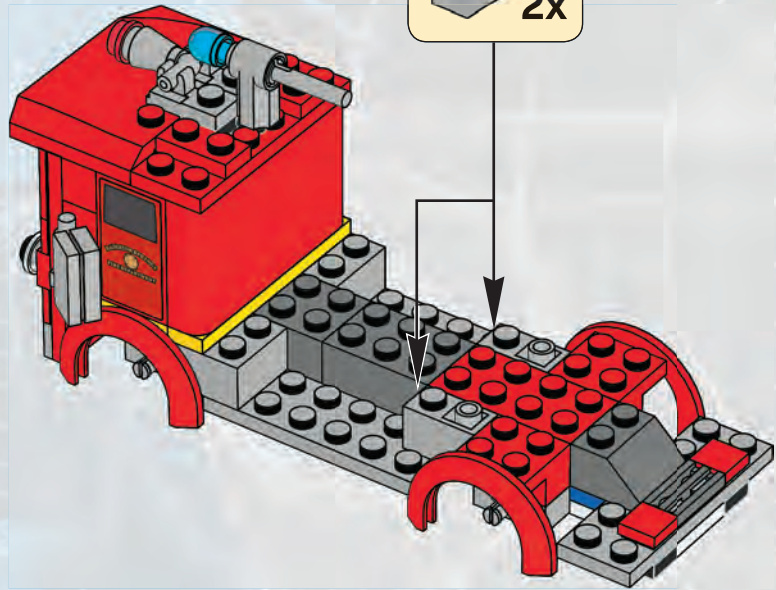



29

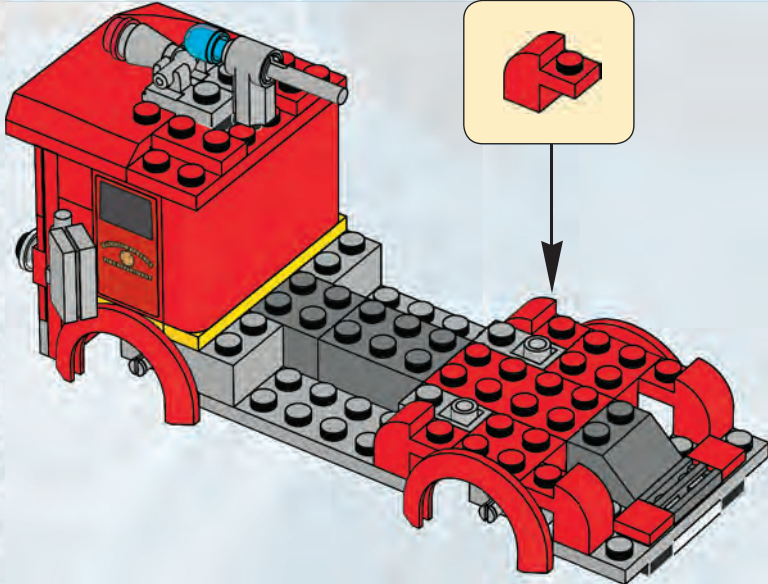

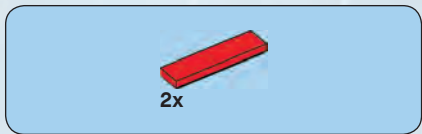

30

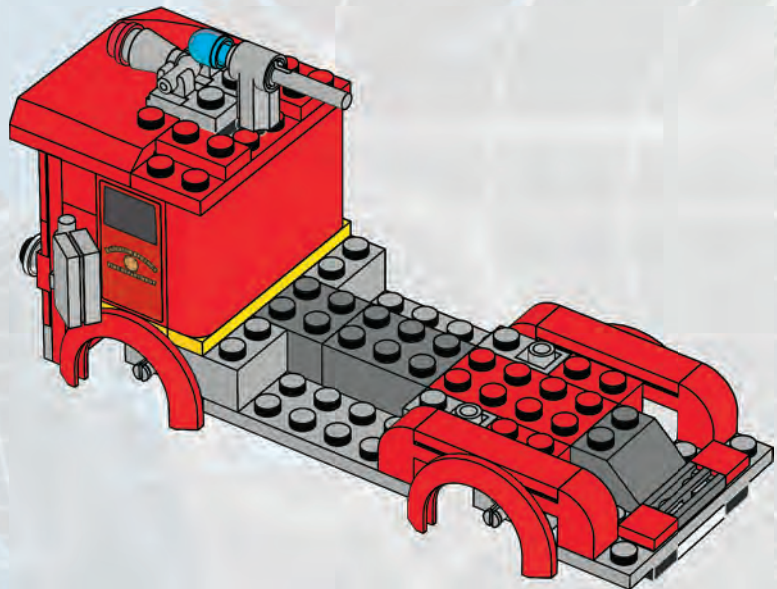

52



31

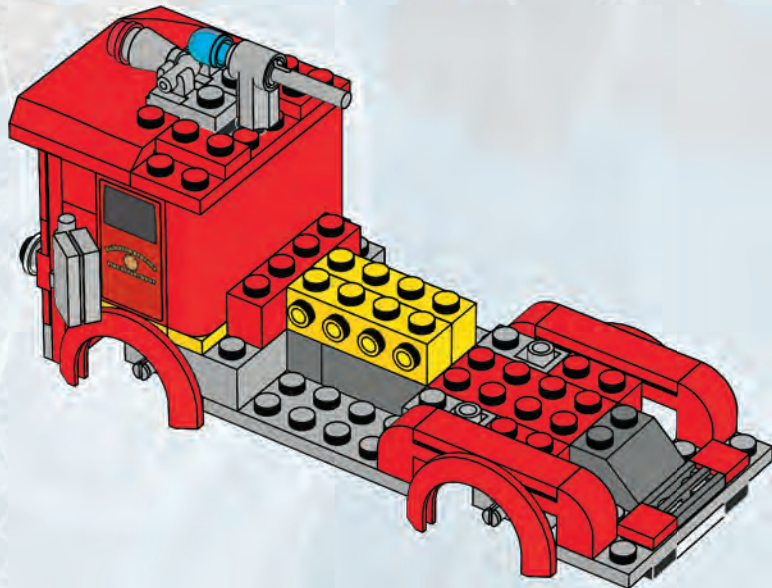

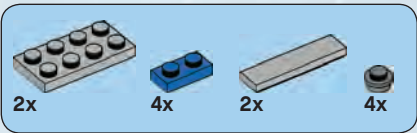

32

1



2

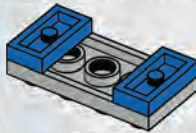

3

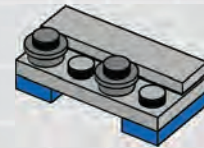

waypoint 2
target acquired

4



2x

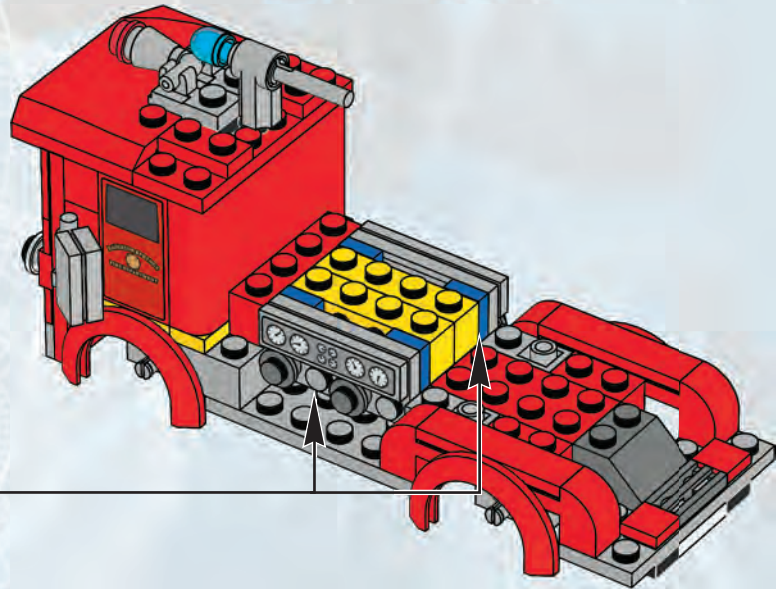

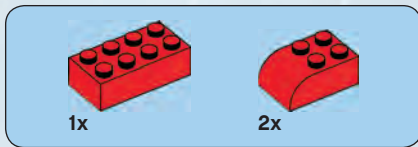

33

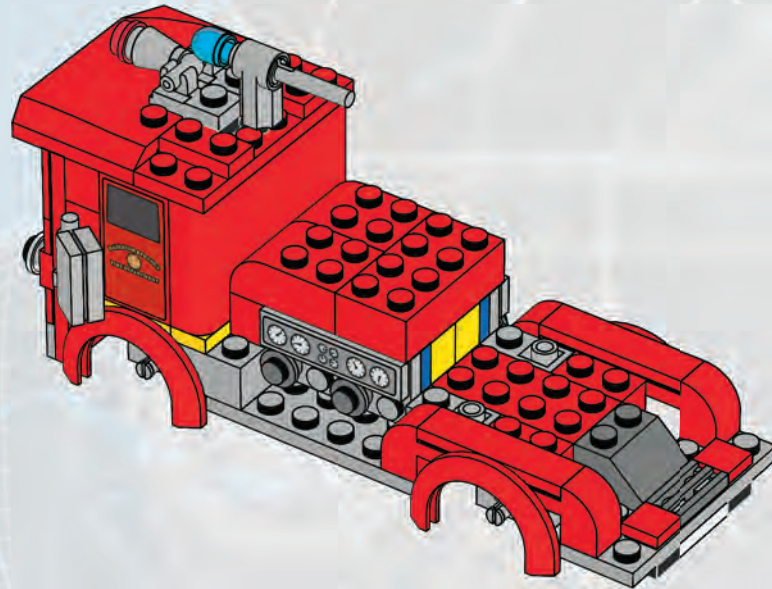

56



1x



1x

34

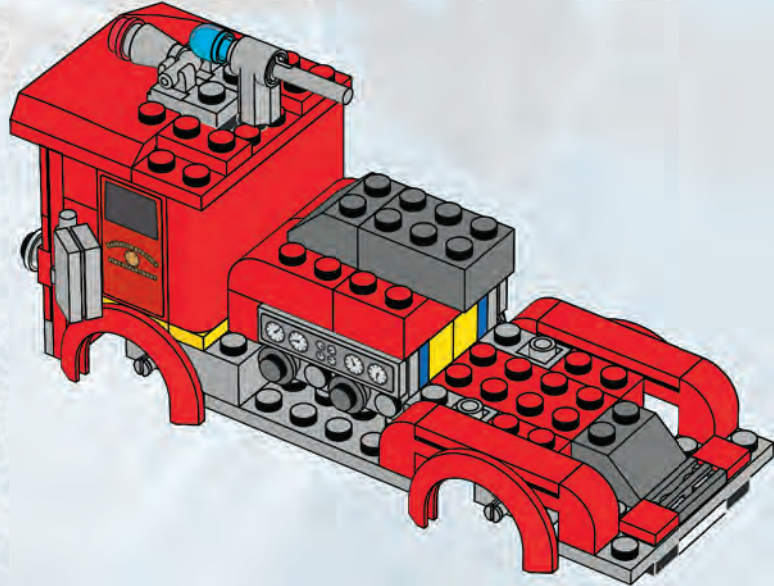



1x



1x

35

Waypoint

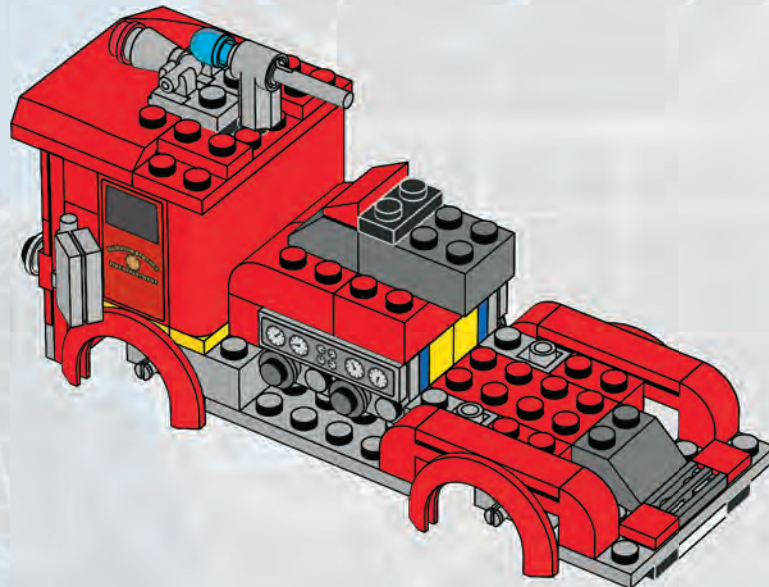

58



1x



1x

36

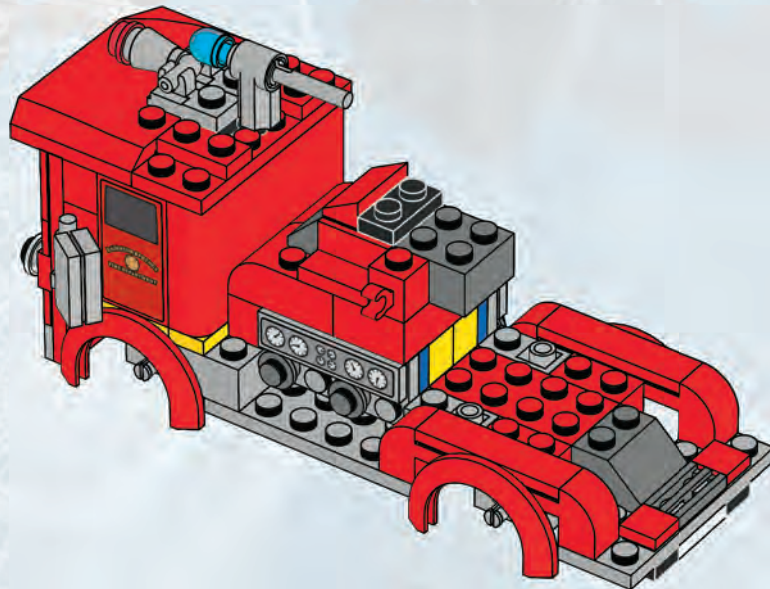



37

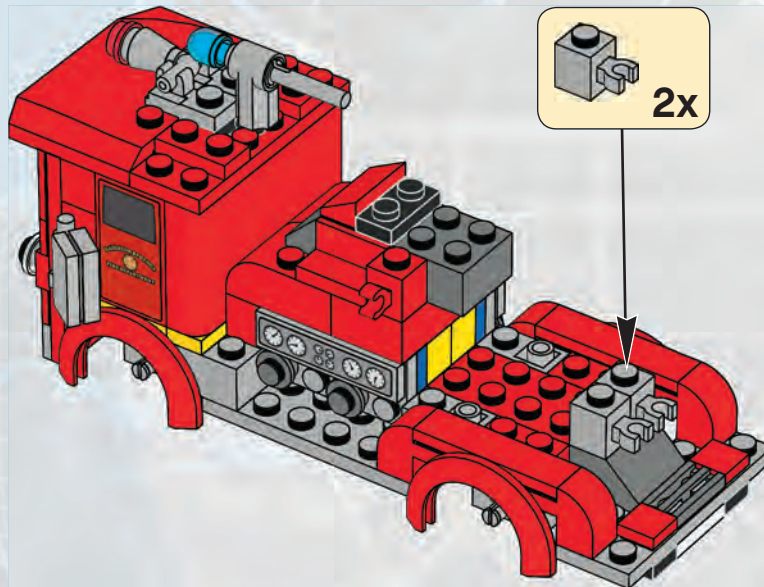

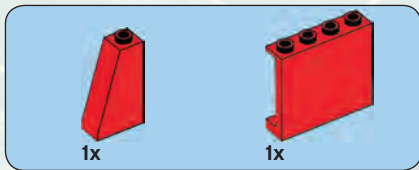

38

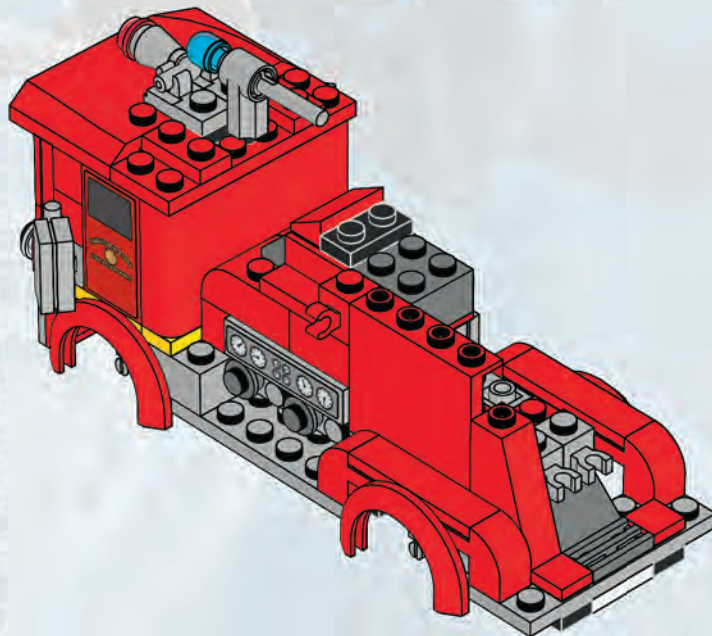

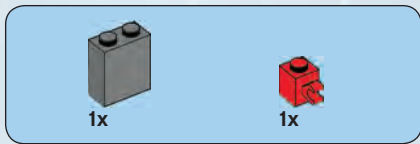

39

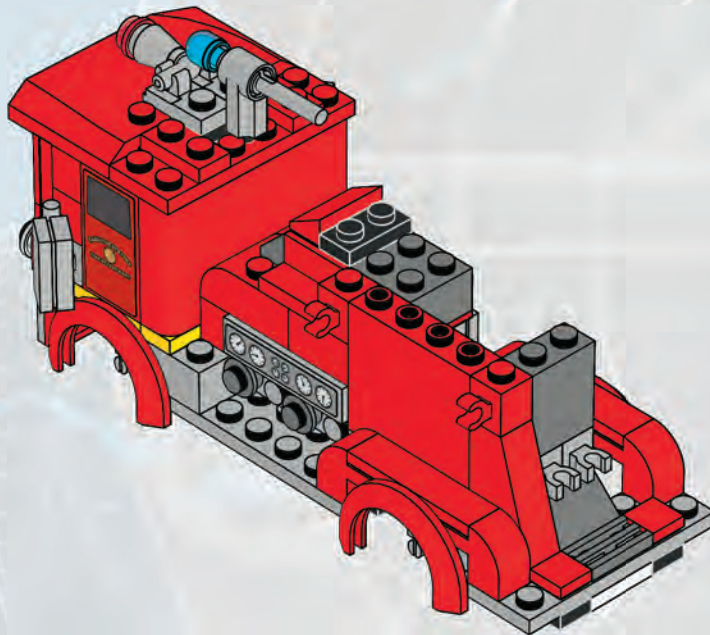

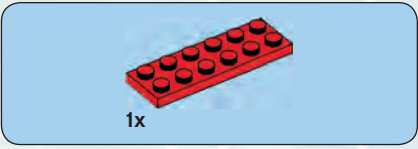

40

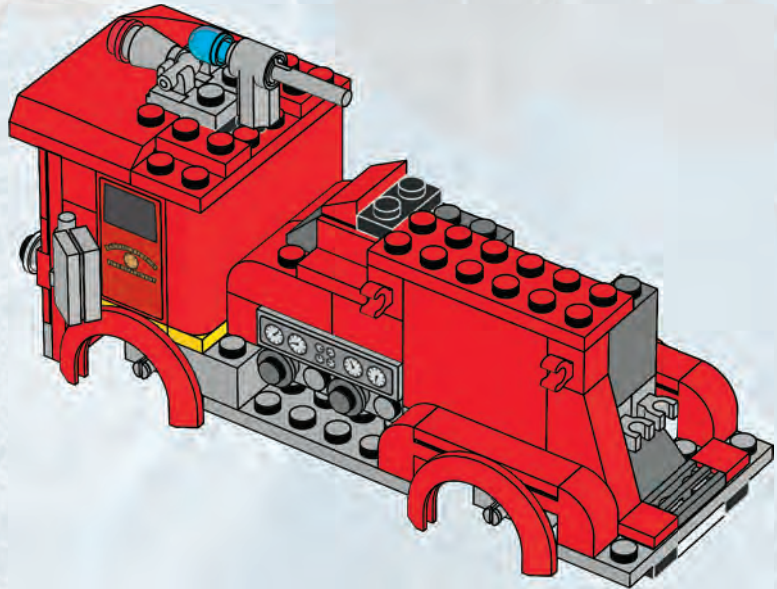



41

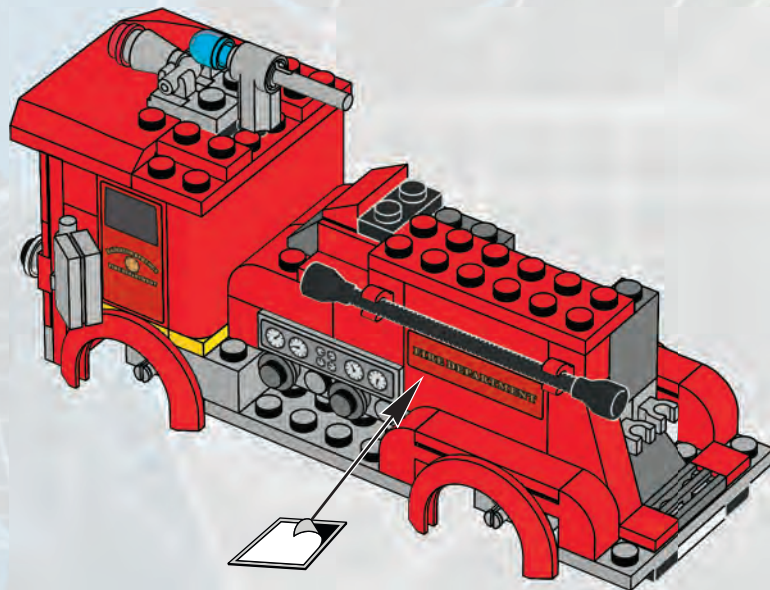

64



1x



1x

42

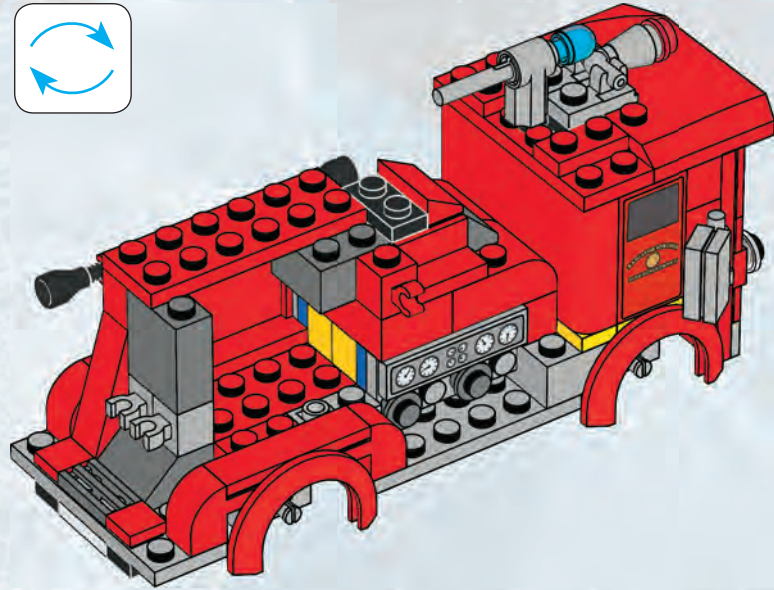
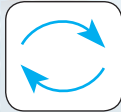

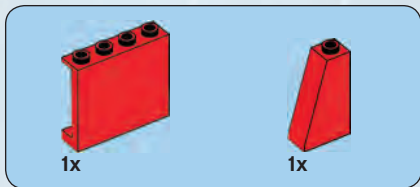

43

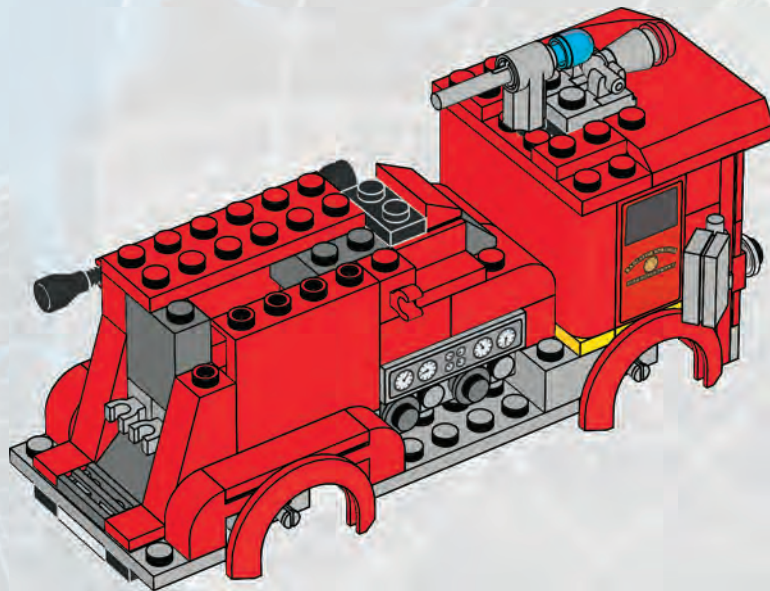

66



1x

44

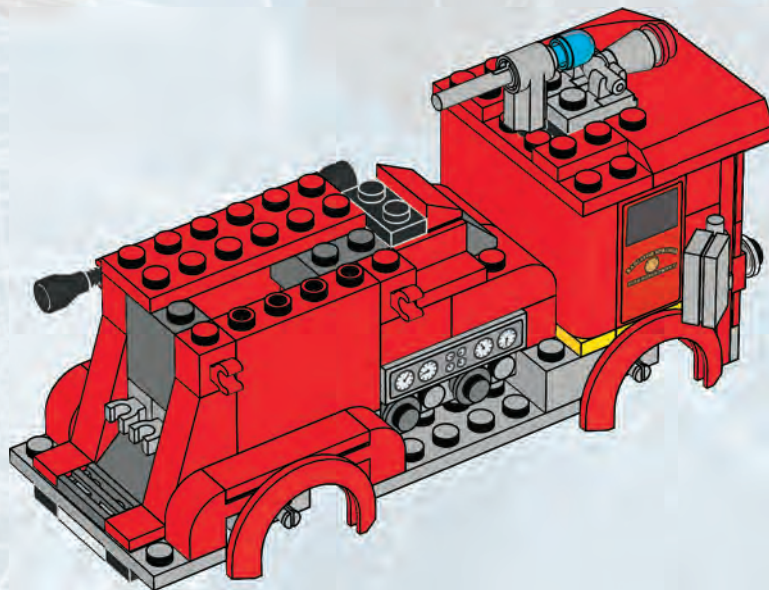

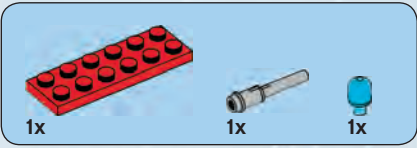

45

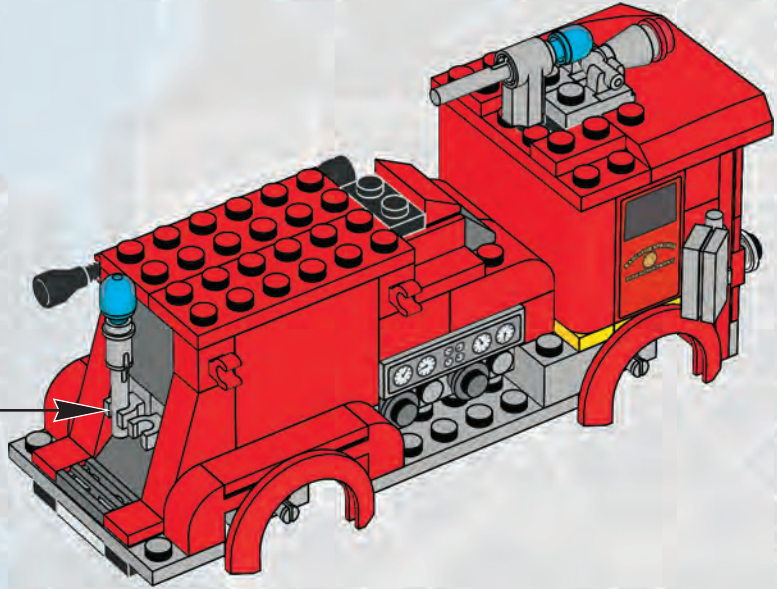
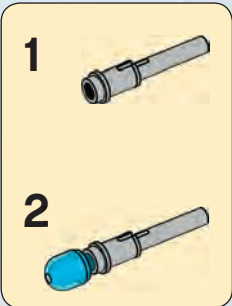



46

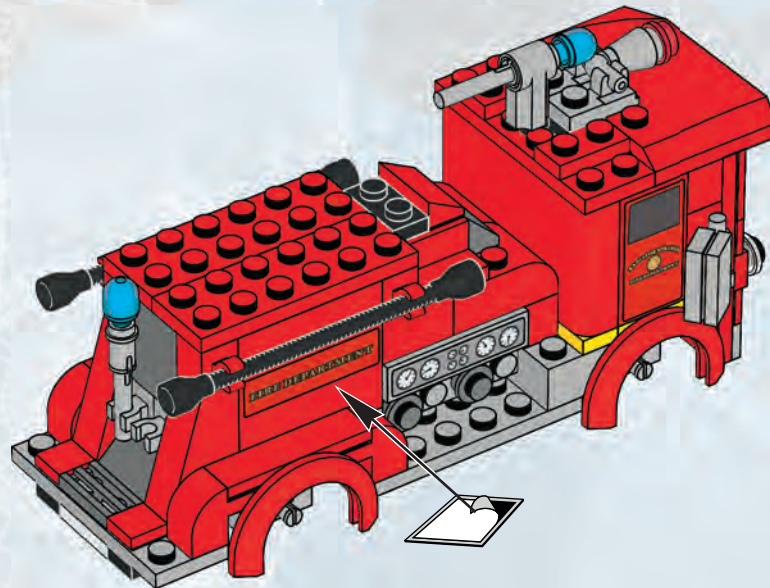



2x

47

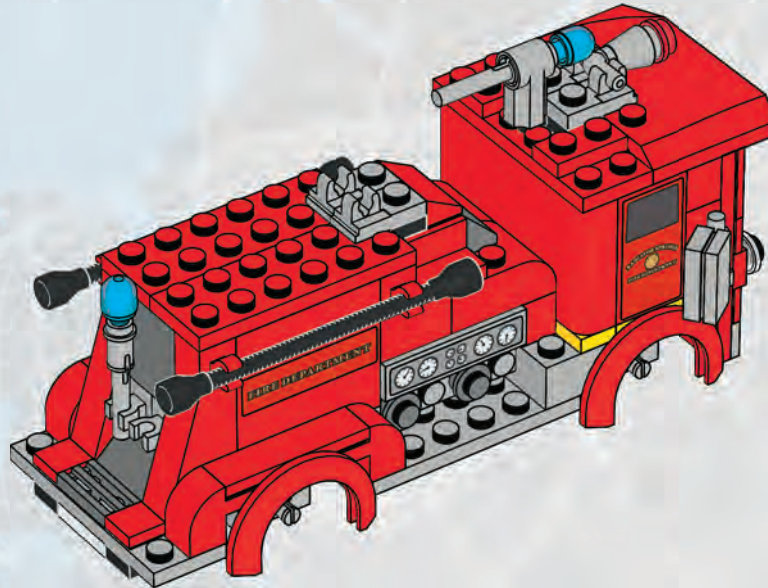

70

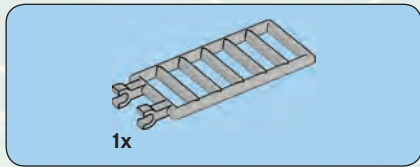

48

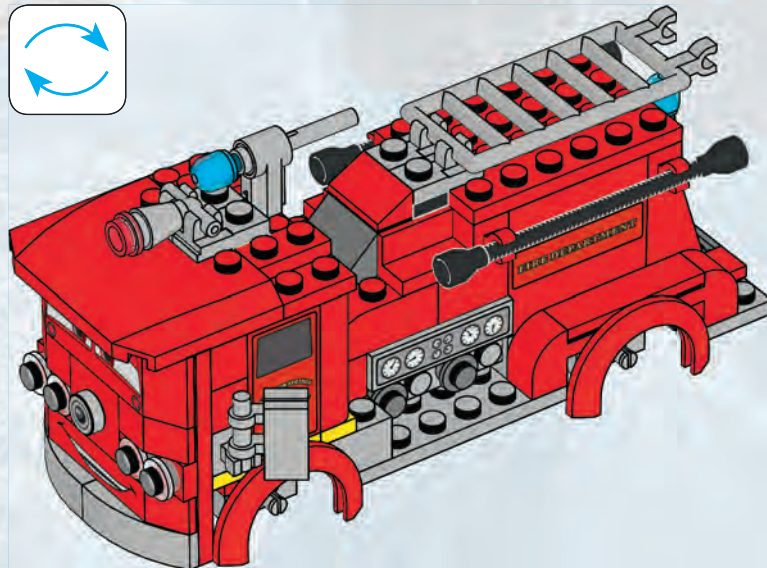
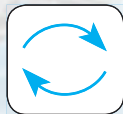

71



4x



4x

49

waypoint

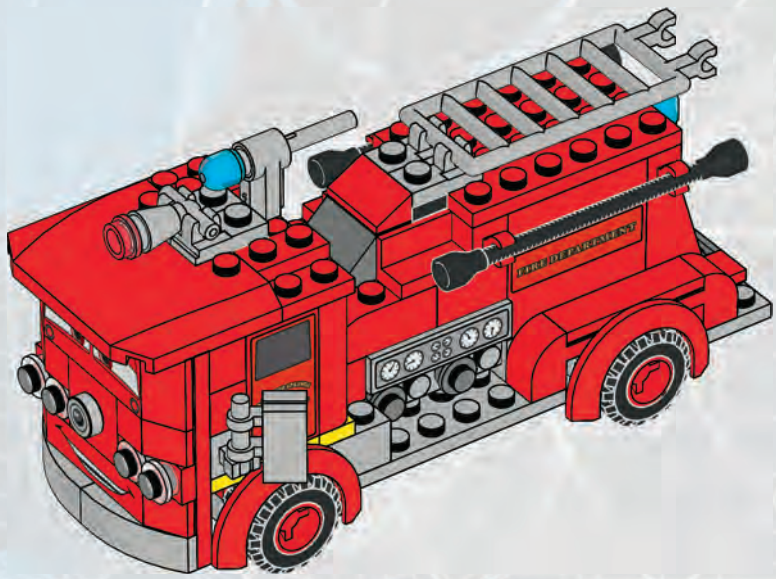

72

waypoint 2

target
acquired

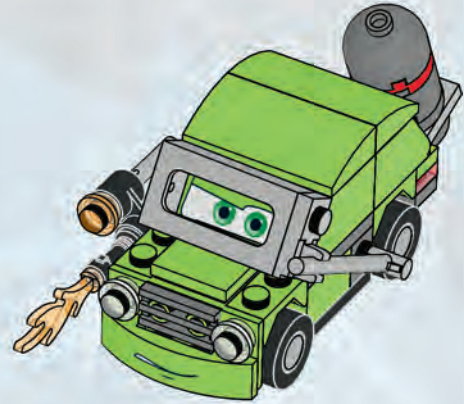
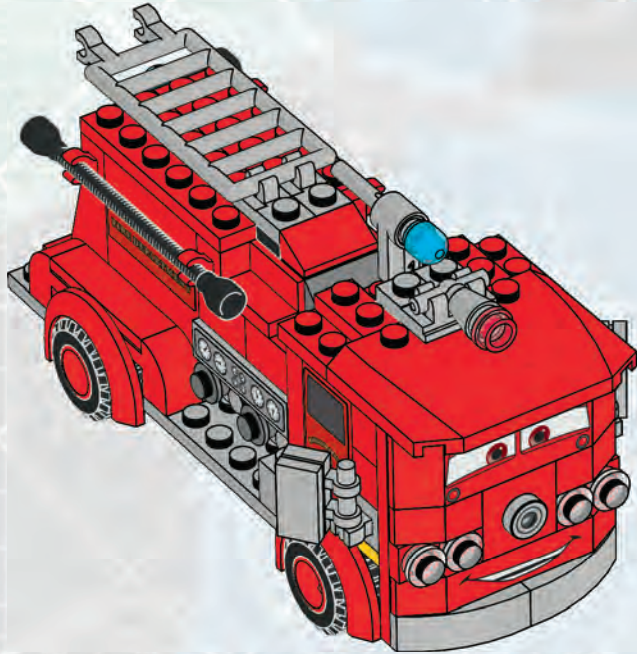



1x
4617072



1x
4187743



1x
4518611



1x
4617067



2x
4600186



1x
4617076



1x
4617077

74



2x
4597561



2x
4164022



1x
4222960



1x
4261397



4x
4533772



1x
4529241



2x
4211437



2x
4211436



2x
4251163



2x
4211397



2x
4211395



2x
4211452



1x
4211474



2x
4211414



5x
4598526



2x
4211632



2x
4515369



2x
4211356



1x
4653967



1x
4233652



1x
4275673



1x
4565433



4x
4211765



4x
4211496



3x
4520320



1x
4211550



1x
4211508



1x
4210978



2x
4211105



1x
4210875



2x
4558955



2x
4249139



1x
4161674



2x
4211054



2x
4210635



2x
4211133



2x
4210631



4x
4210633



2x
4211042



2x
302301



2x
303401



1x
4114309



2x
300521



1x
301021

4x
4504379

3x
4651524

2x
4162628

4x
609121

2x
621521

2x
302321

1x
4581308

1x
366621

2x
403221

3x
379521

1x
4144302

4x
307021

1x
4654535

1x
4654537

2x
243121

4x
4535766

2x
300121

1x
300921

2x
486521

2x
4655549

2x
4558212

4x
4659550

4x
4294734

1x
4259903

1x
4585642

10x
302323

3x
4164073

2x
366624

1x
4567996

3x
302326

2x
366626

1x
4569733

1x
4556158

1x
4598897

4x
4568644

1x
244126

2x
4558850

1x
4562148

4x
4508215

2x
371028

6x
3005740

2x
3000841

1x
3005741

2x
4497952



Customer Service
Kundenservice
Service Consommateurs
Servicio Al Consumidor

www.lego.com/service or dial

: 00800 5346 5555
: 1-800-422-5346

2011



8639



8423, 8639, 8679



8426



8487



8200, 8487



8487



8206, 8484, 8679



8206, 8679



8487



8424



8639



8423, 8679



8638



8638



8487



8638



8638



8638

2011



8201, 8487



8639



8639



8486



8426, 8639



8639



8426



8638



8486



8679



8679



8679



8679



8424

2012



9486



9485



9486



9481



9480



9483



9484



9485



9479



9484



9486



9483



9486



9485



9486



9485



9478

9486





WIN!

Go to www.LEGOsurvey.com/product
to fill out a survey for a chance
to win a cool LEGO® Product.

No purchase necessary.

Open to all residents where not prohibited.

www.LEGOsurvey.com/product

GEWINNE!

Nimm an der Umfrage auf
www.LEGOsurvey.com/product
teil und hab die Chance ein cooles
LEGO® Produkt zu gewinnen!
Die Teilnahme am Gewinnspiel führt zu keinerlei
Kaufverpflichtungen. Teilnahme in allen nicht
ausgeschlossenen Ländern möglich.

WIN!

Ga naar www.LEGOsurvey.com/product,
vul een enquêteformulier
in en maak kans op een
cool LEGO® product.
Geen aankoopverplichting.
Iedereen mag deelnemen, uitgezonderd
ingezetenden van landen waar een
enquêteverbod geldt.

GAGNE !

Visite www.LEGOsurvey.com/product
pour répondre à un
questionnaire et avoir une
chance de gagner un produit
LEGO® très cool !
Aucune obligation d'achat.
Ouvert à tous les résidents des pays
autorisés.

当てよう!

www.LEGOsurvey.com/product
にアクセスして、
アンケートにご記入ください。
当選者にはレゴ®製品を
差し上げます。
お買い上げの必要はありません。
禁止されていない限り、すべての皆様にご利用いただけます。

LEGO and the LEGO logo are trademarks of the/sont des marques de commerce de/
son marcas registradas de LEGO Group. ©2012 The LEGO Group.

Disney/Pixar elements: © Disney/Pixar, not including underlying vehicles owned by third parties: Pacer is a trademark of Chrysler LLC
Les éléments Disney/Pixar : © Disney/Pixar, sans inclure les véhicules sous-jacents qui sont la propriété de tiers :

Pacer est une marque de commerce de Chrysler LLC.

Elementos Disney/Pixar. © Disney/Pixar, sin incluir los vehículos subyacentes propiedad de terceros:
Pacer es una marca registrada de Chrysler LLC.

 www.LEGO.com

6003836