

**LEGO**



8677



1

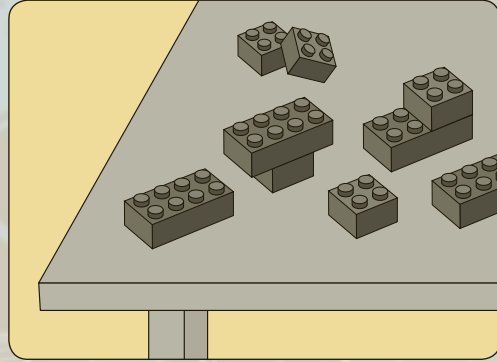
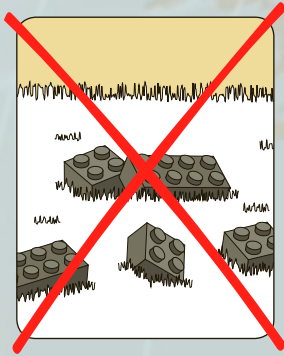

2



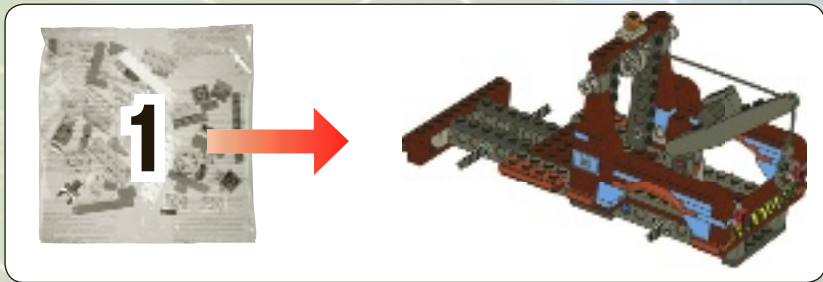

1





2

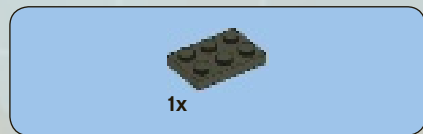

3

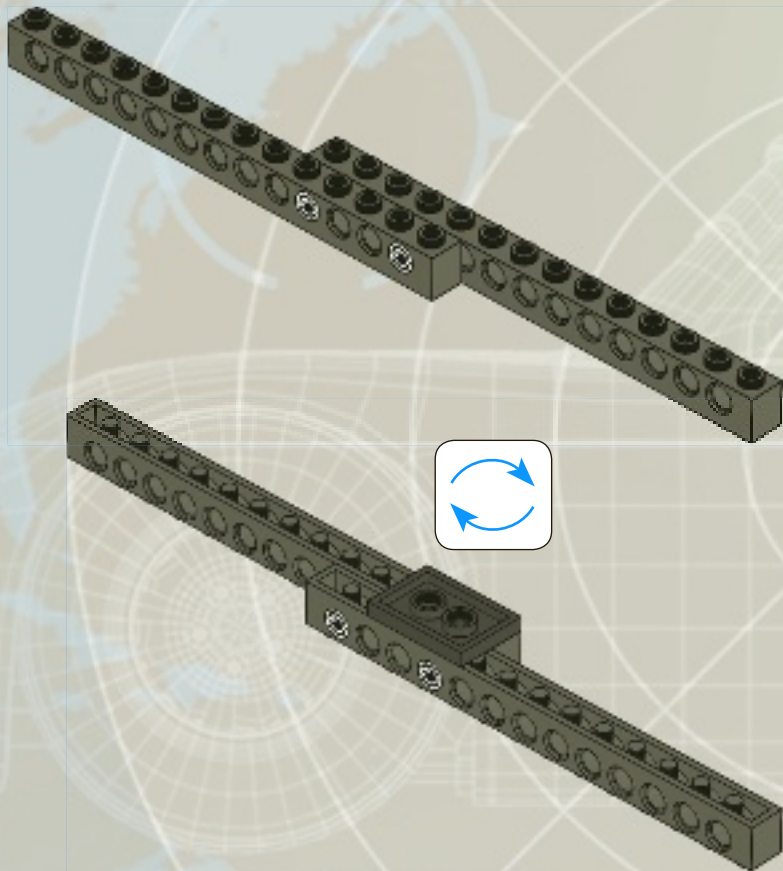

4

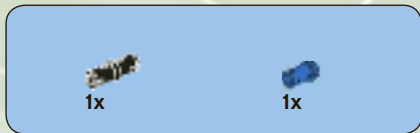

4

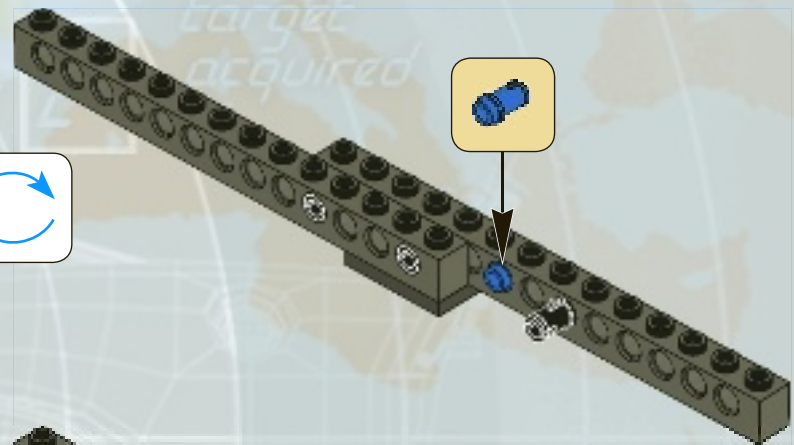

5

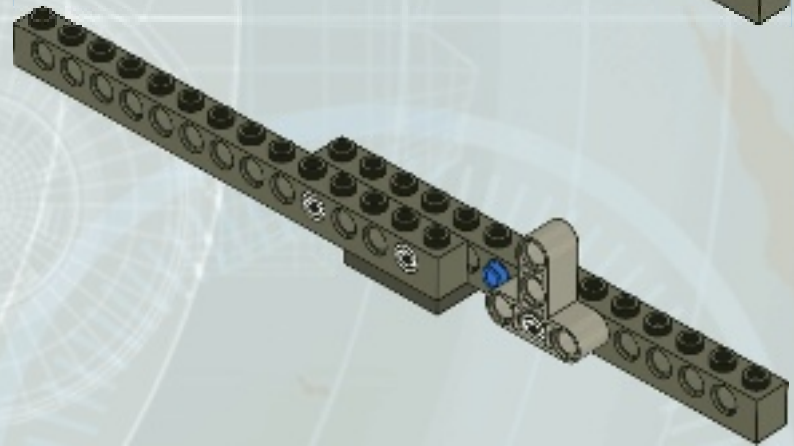



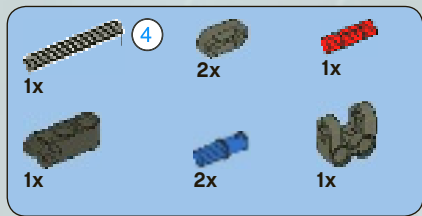

6

1



2



3



4

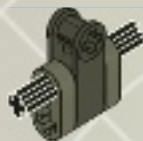

5

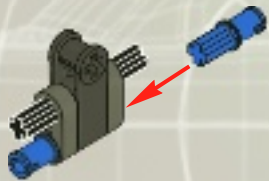

6

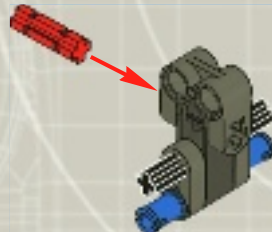

waypoint

2

target  
acquired

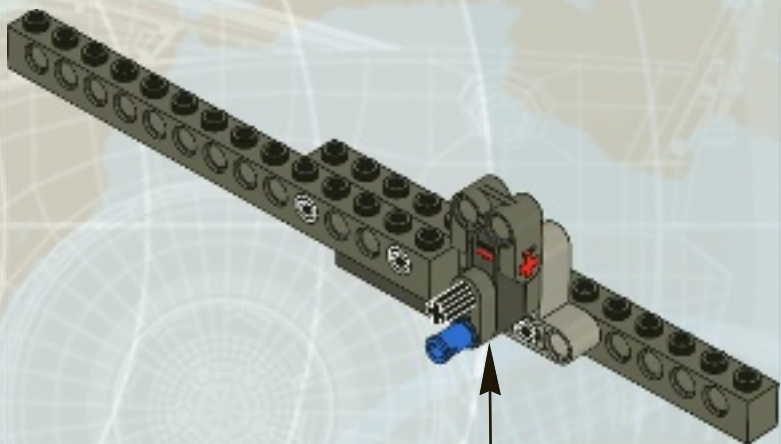

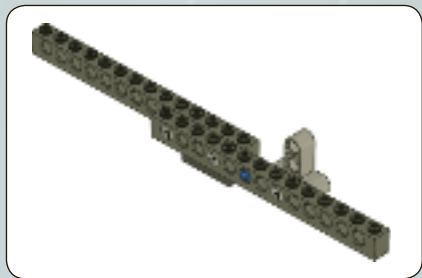

1

8





2

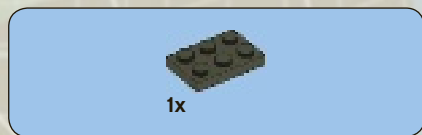

3

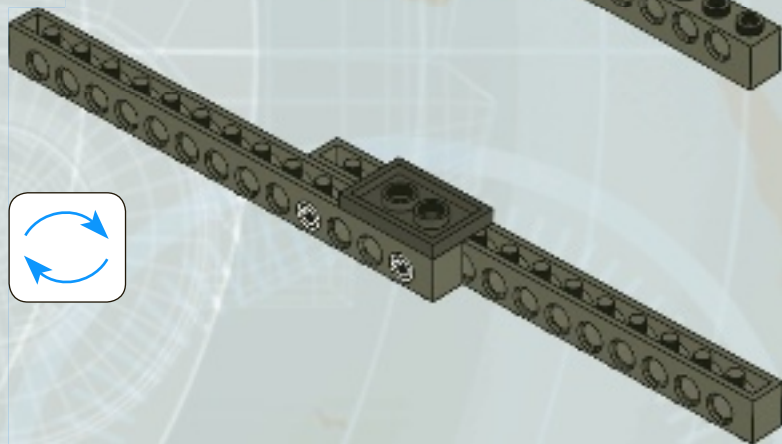
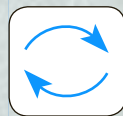

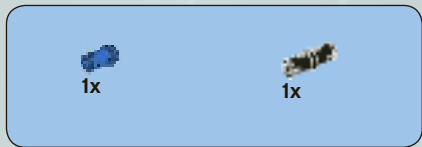

4

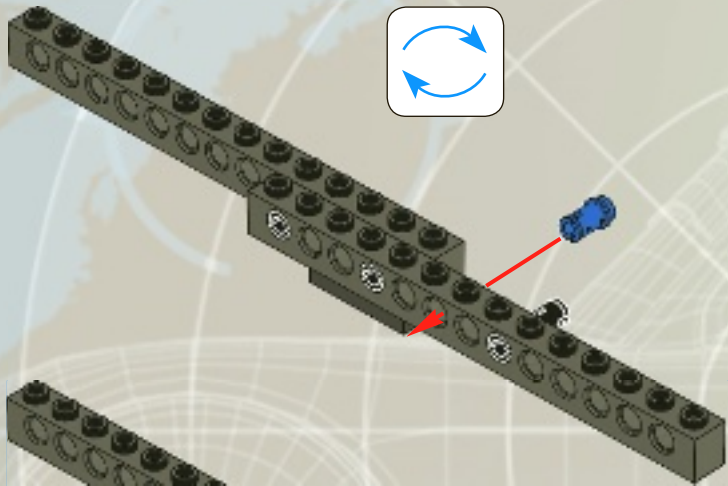

5

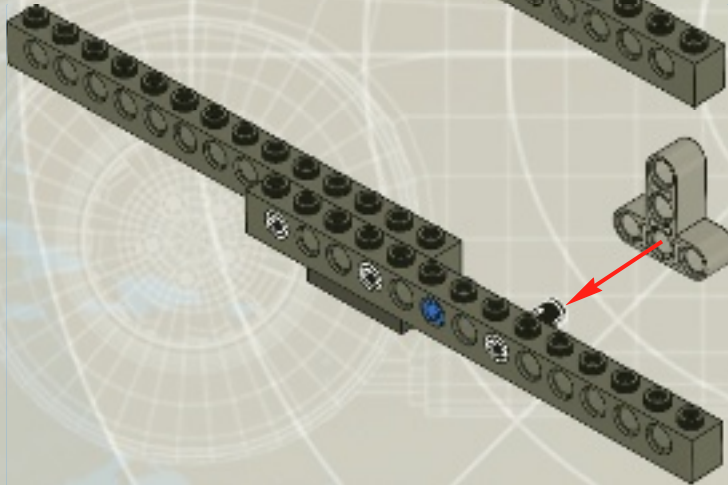

waypoint

2

target  
acquired

7

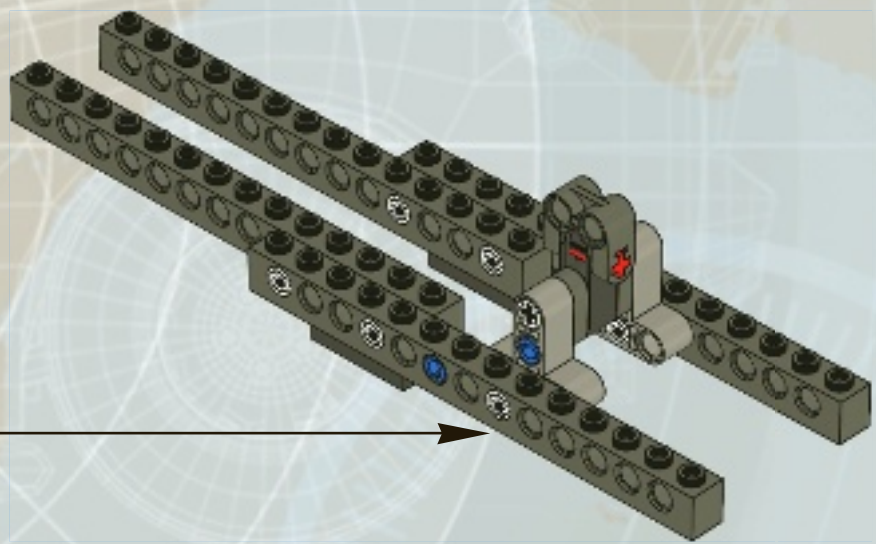

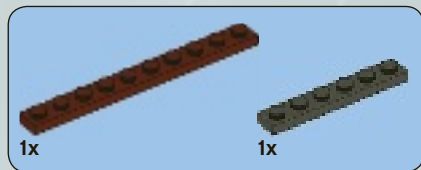

8

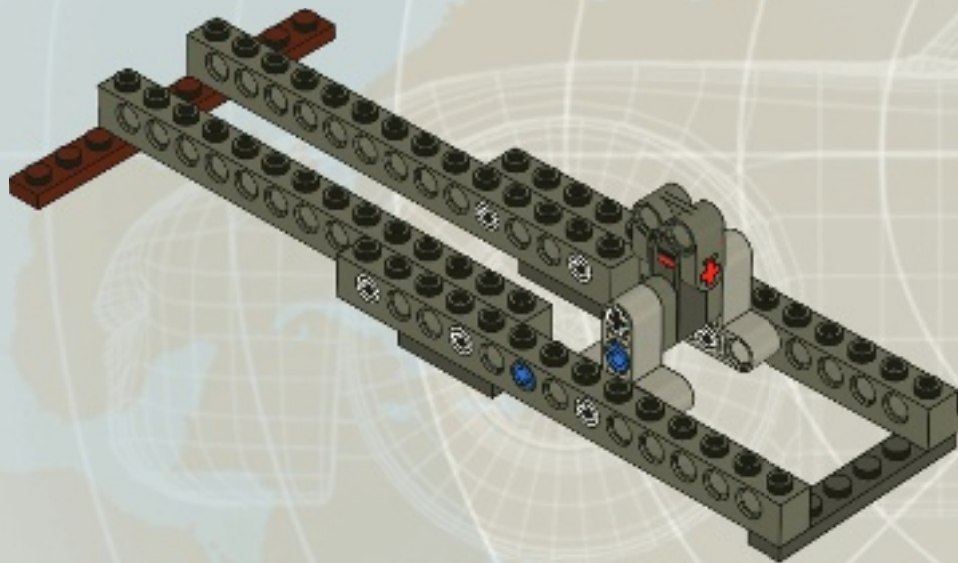

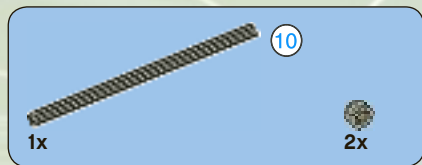

9

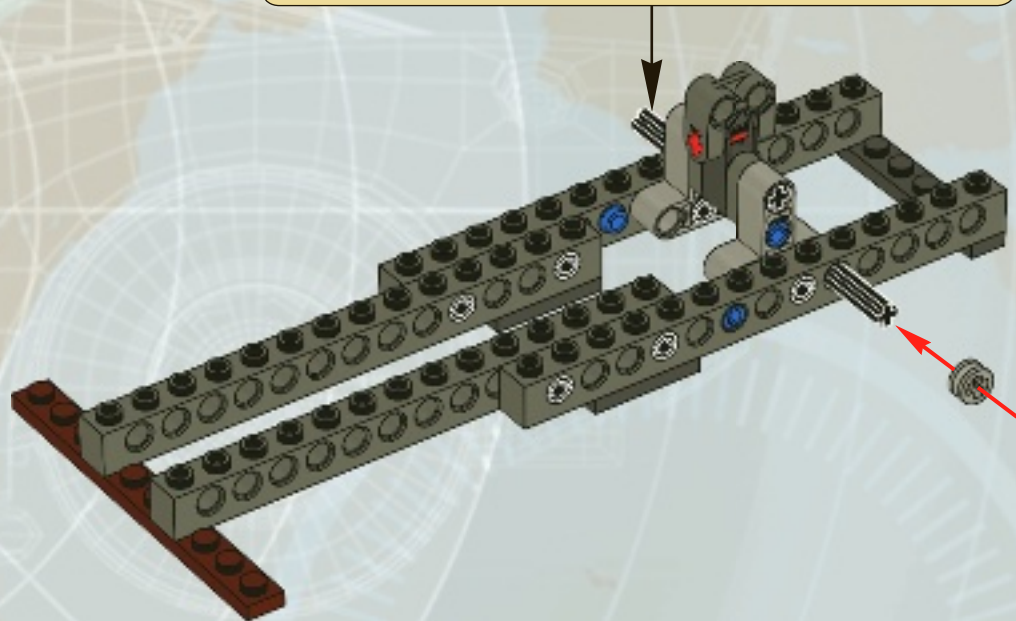



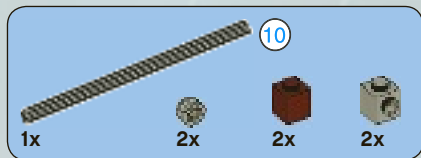

10

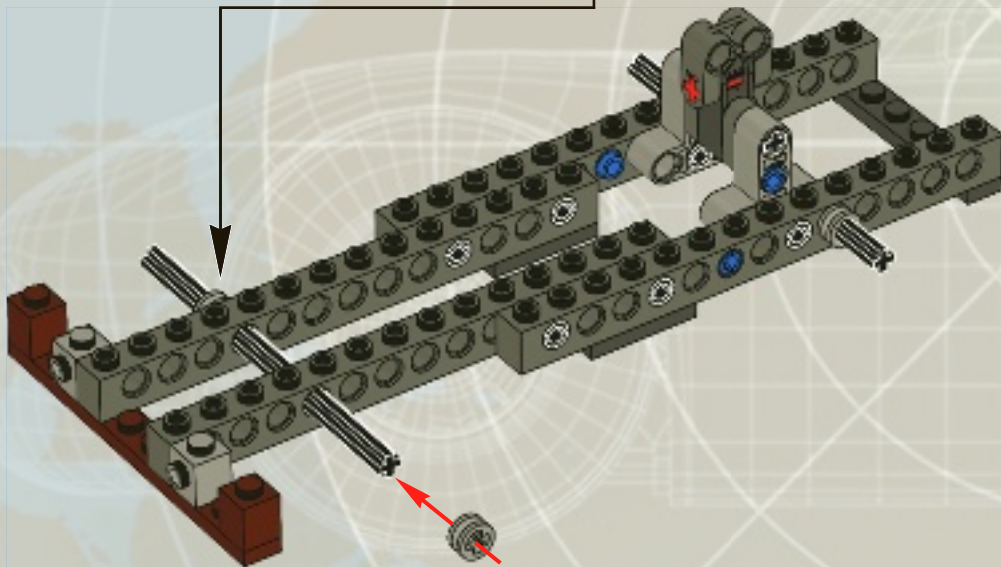

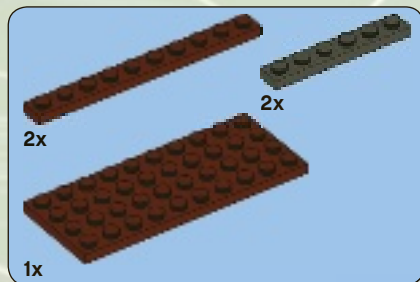

11

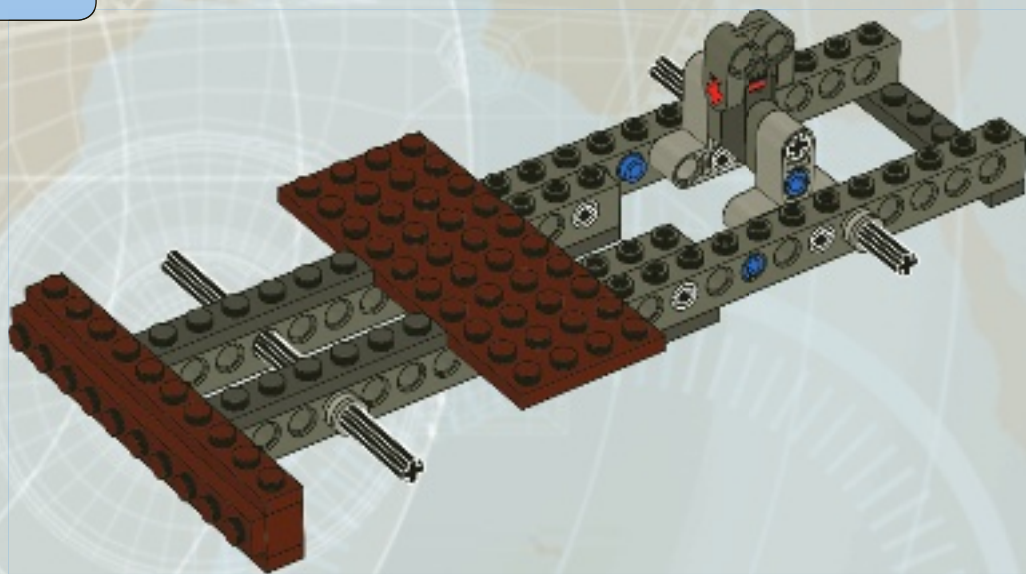

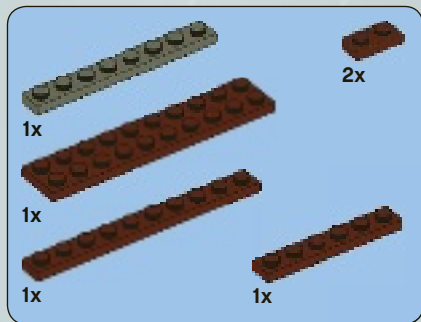

12

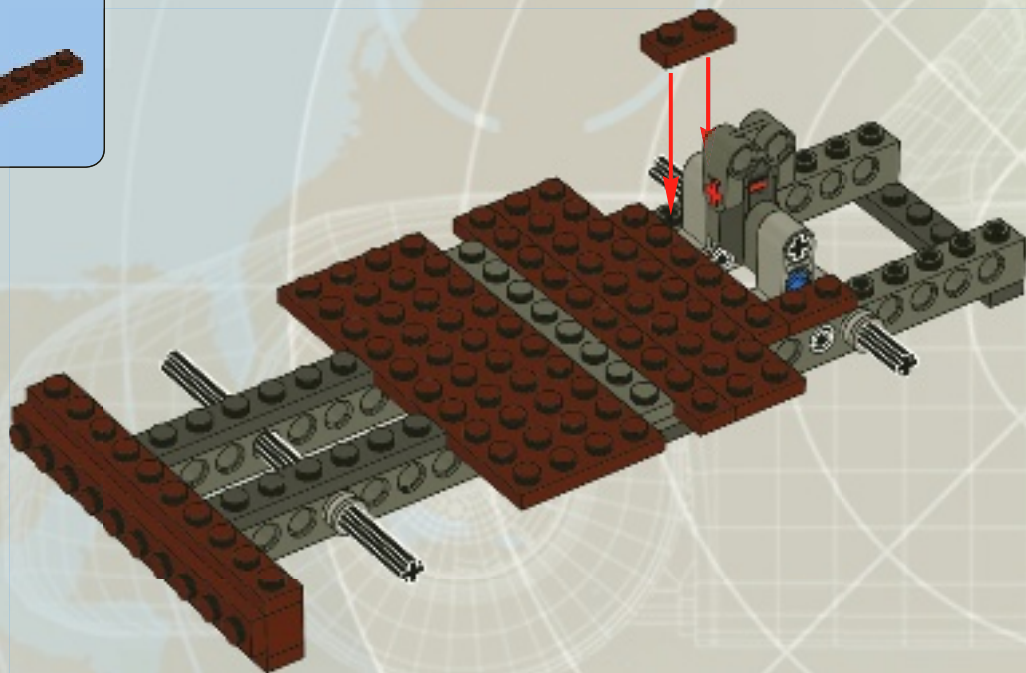

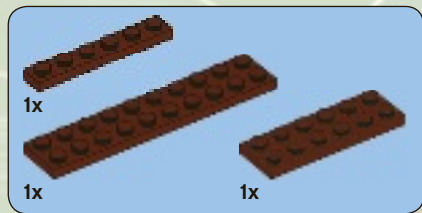

13

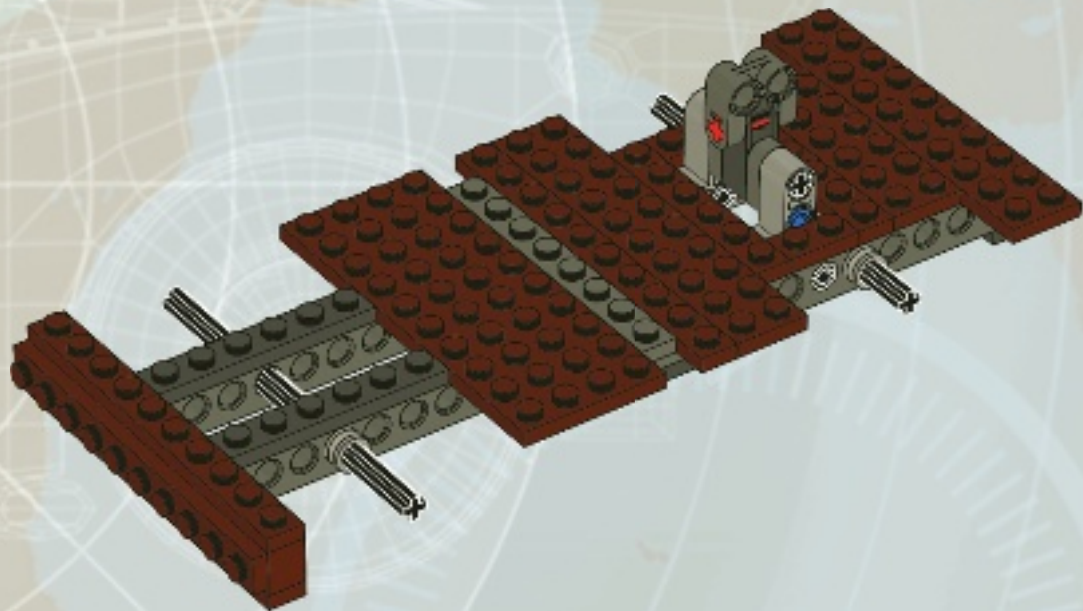

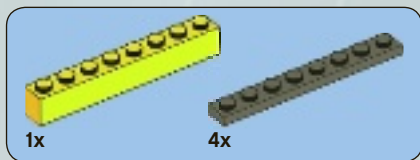

14







2x



8x

15

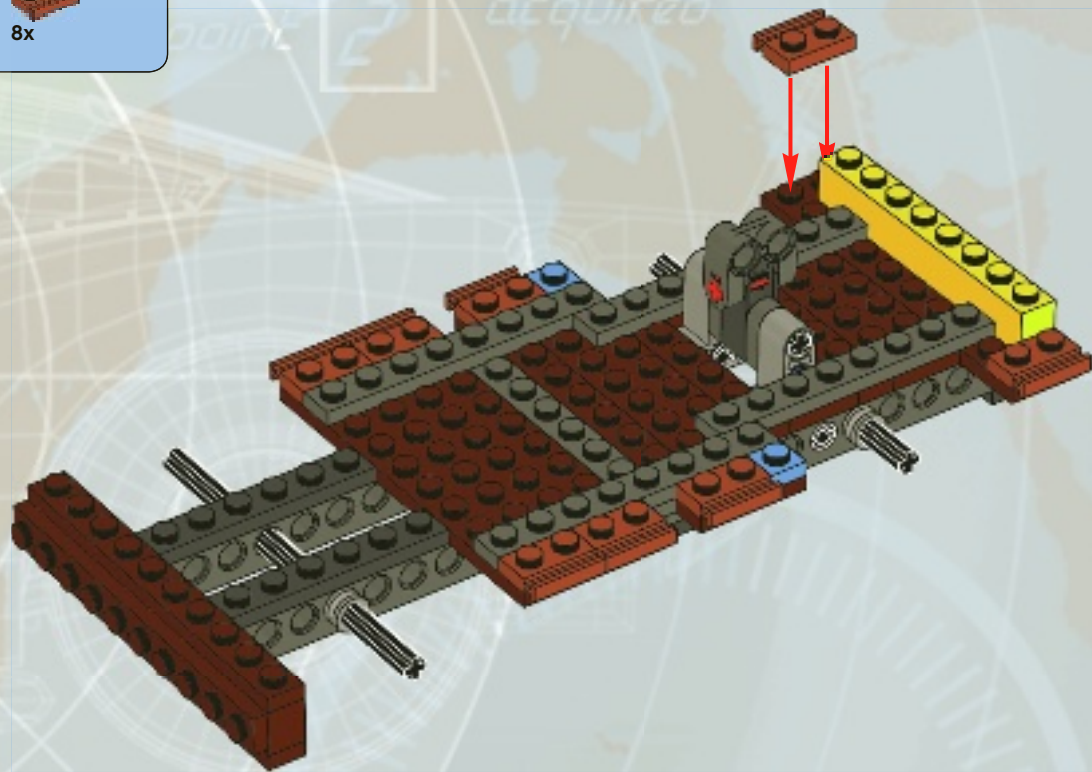

4x  4x 

16

2x 

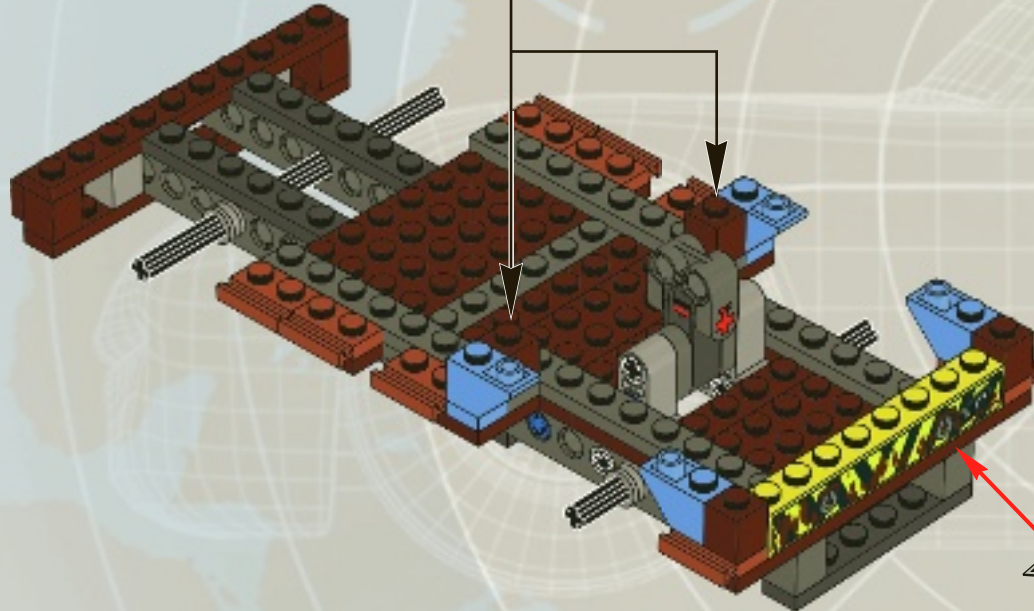







2x

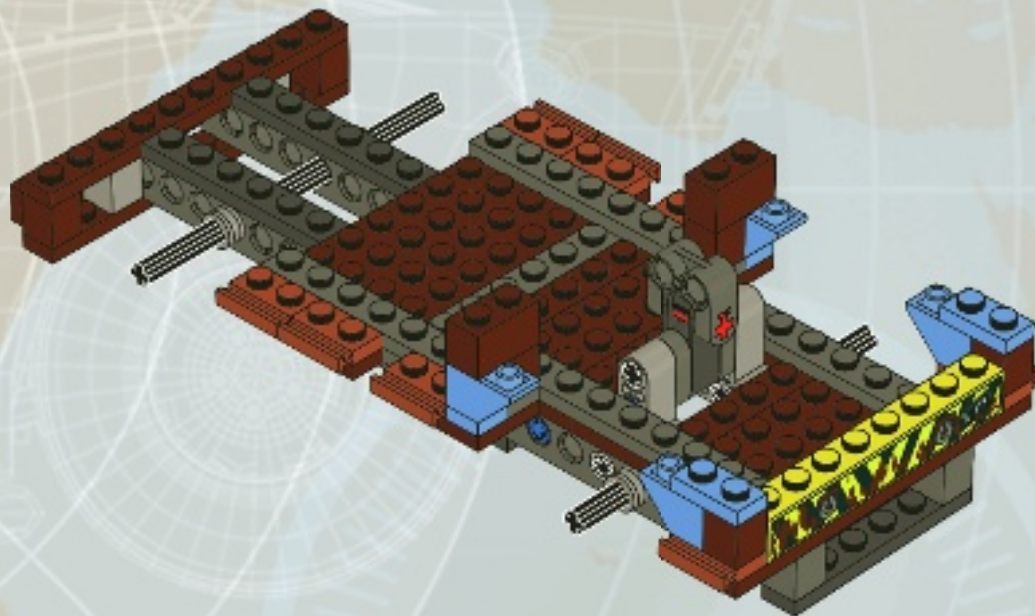

2x

17



2x  1x  2x 

# 18

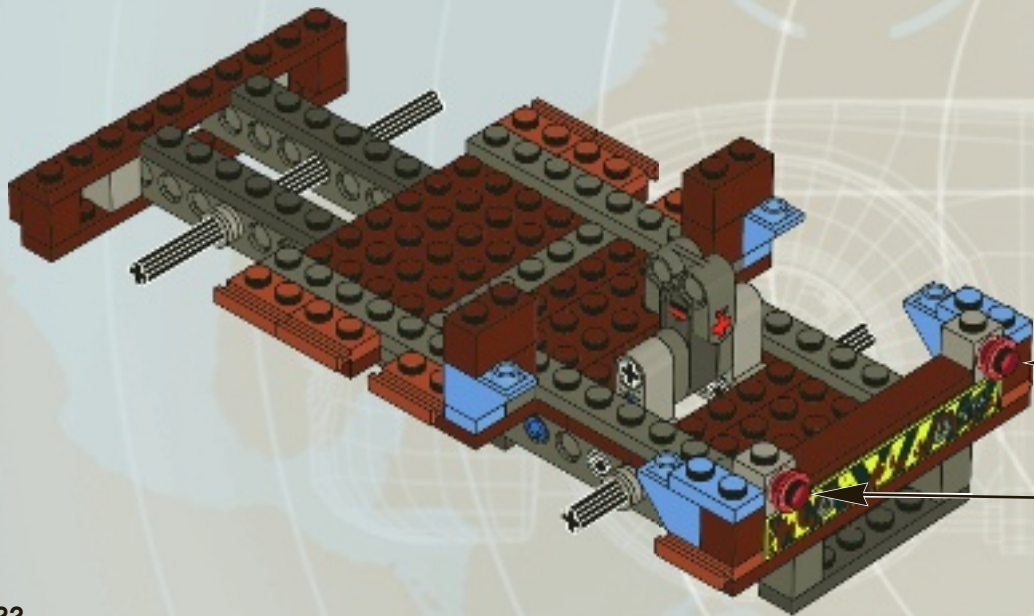

1 

2  2x



2x

19

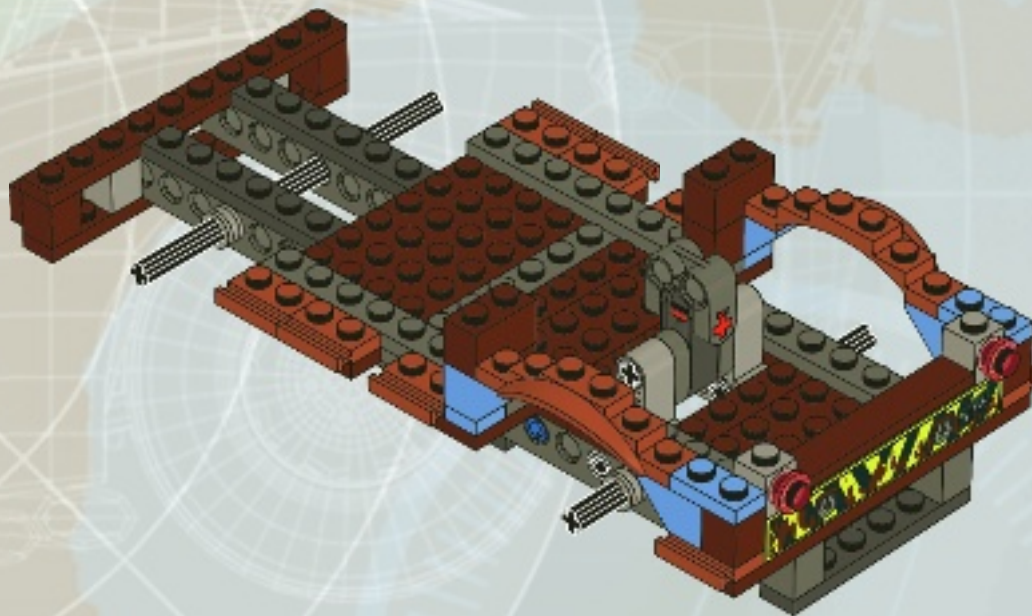





2x



2x

20

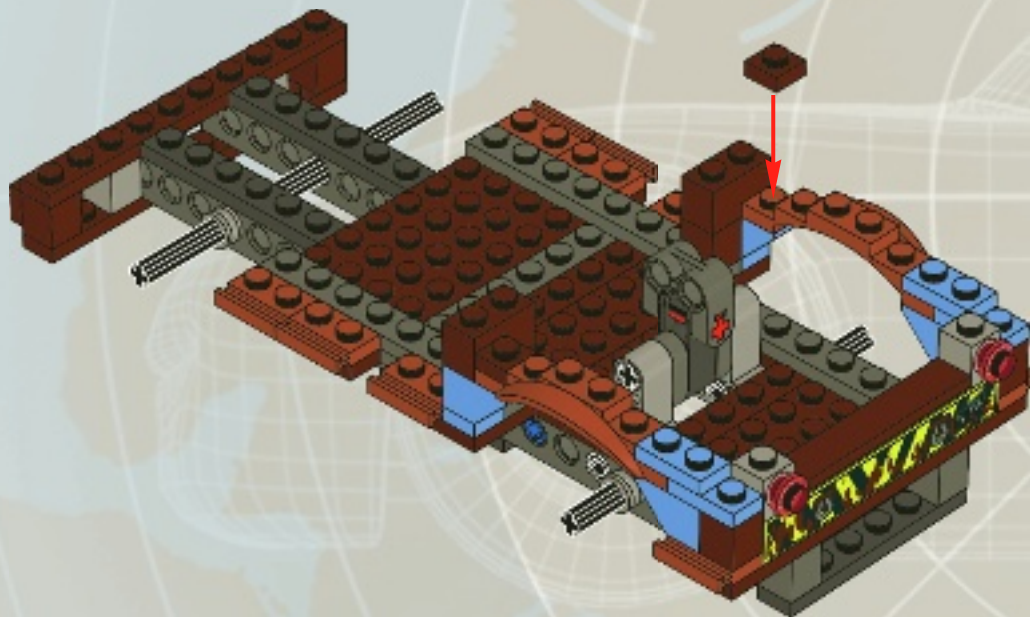



4x



2x

21

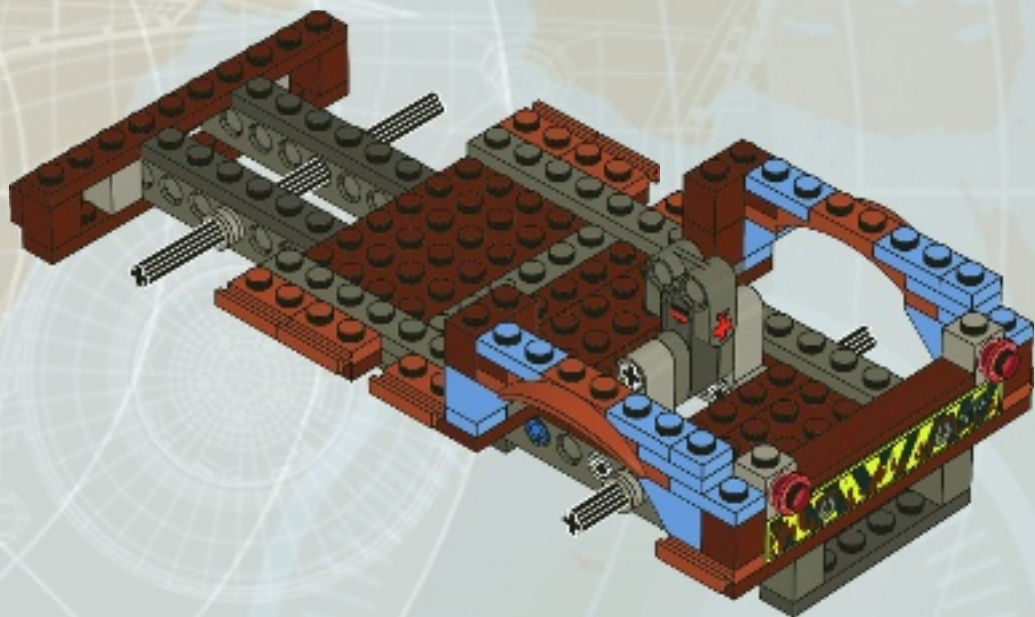



2x



2x



2x

# 22

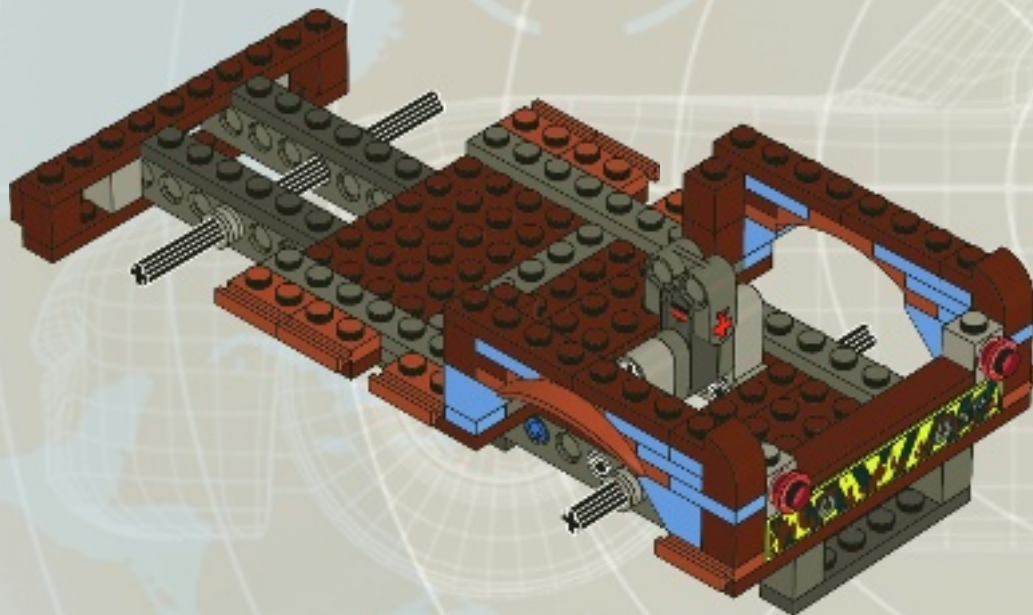



23

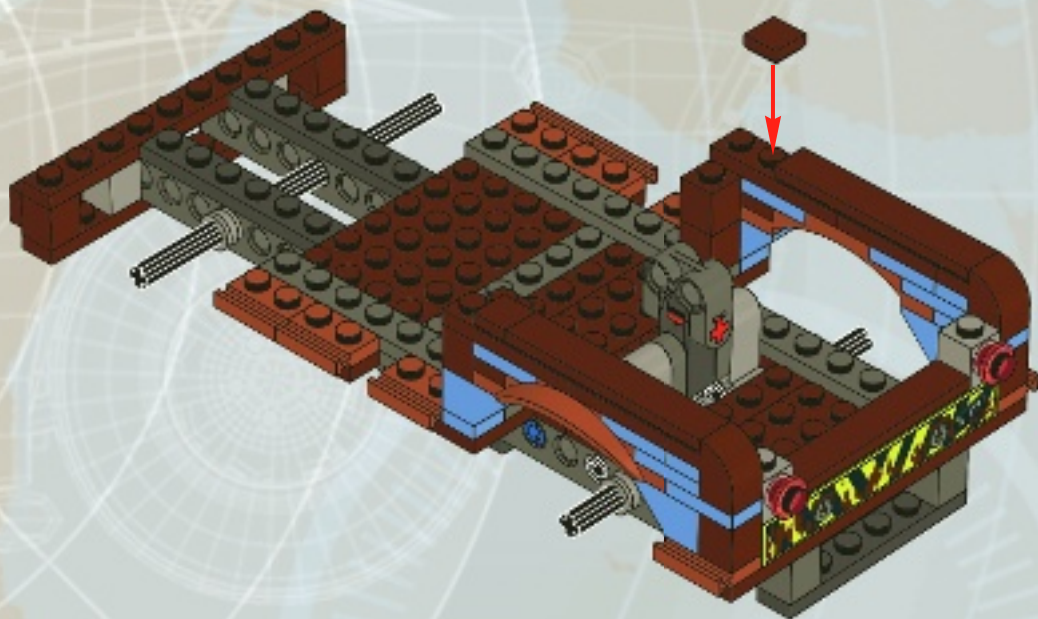

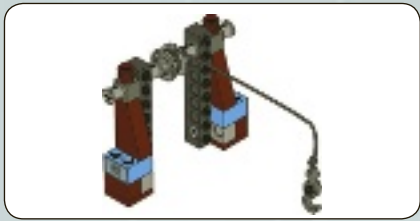

1

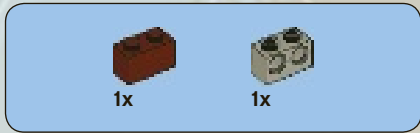

2

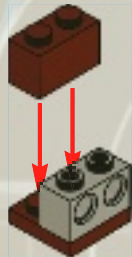

3







4



5



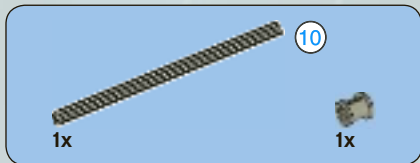

6

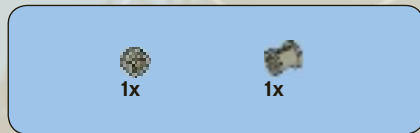
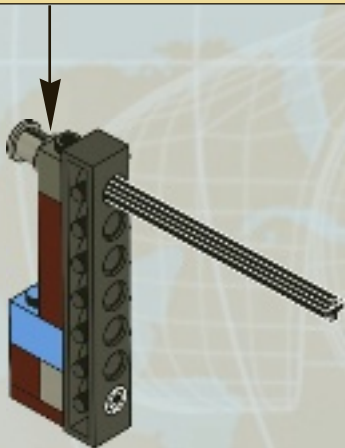
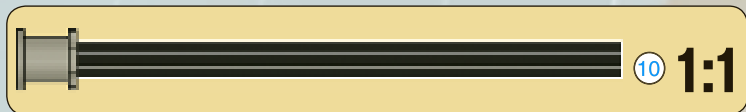

7

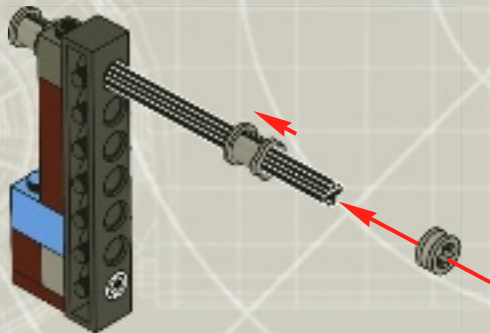

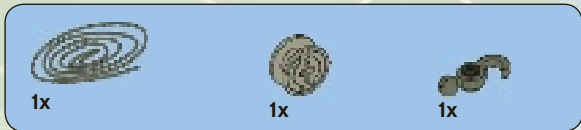

8

1



2



target  
acquired

waypoint

7

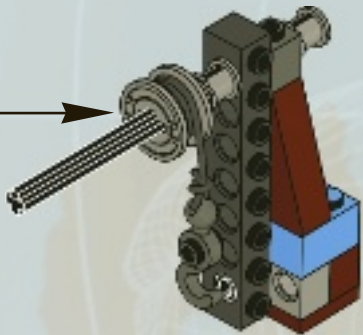

1x



1x

9

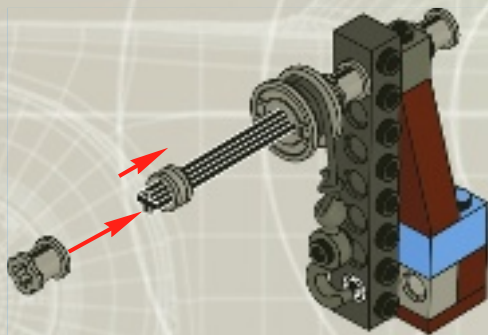

target  
acquired

point 2

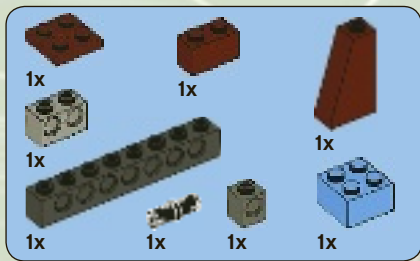

# 10

1



2

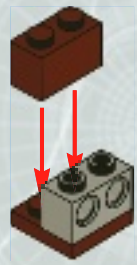

3



4



5

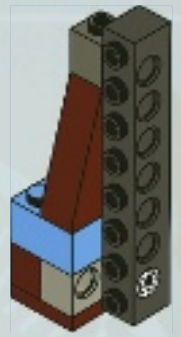



waypoint

7

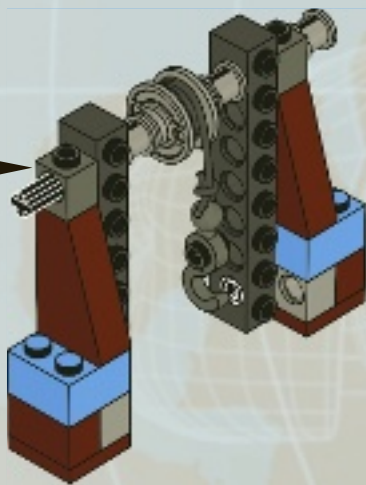

1x

11

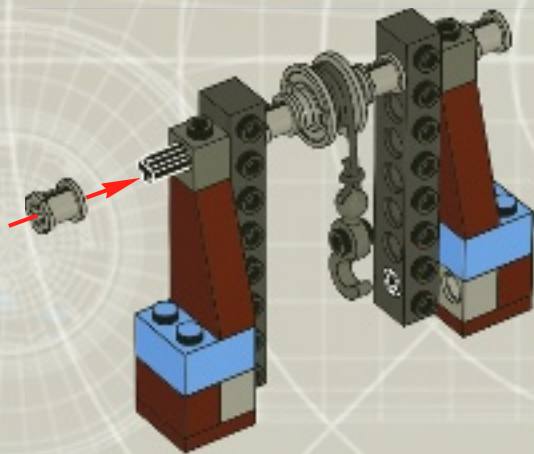



4x

12

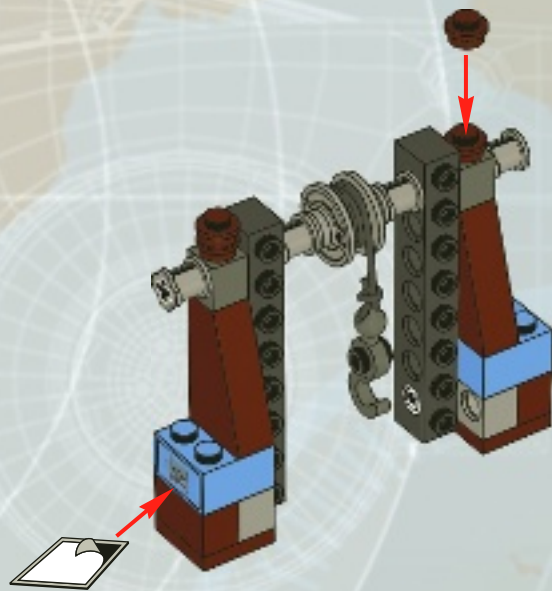

target  
acquired

point

2

24

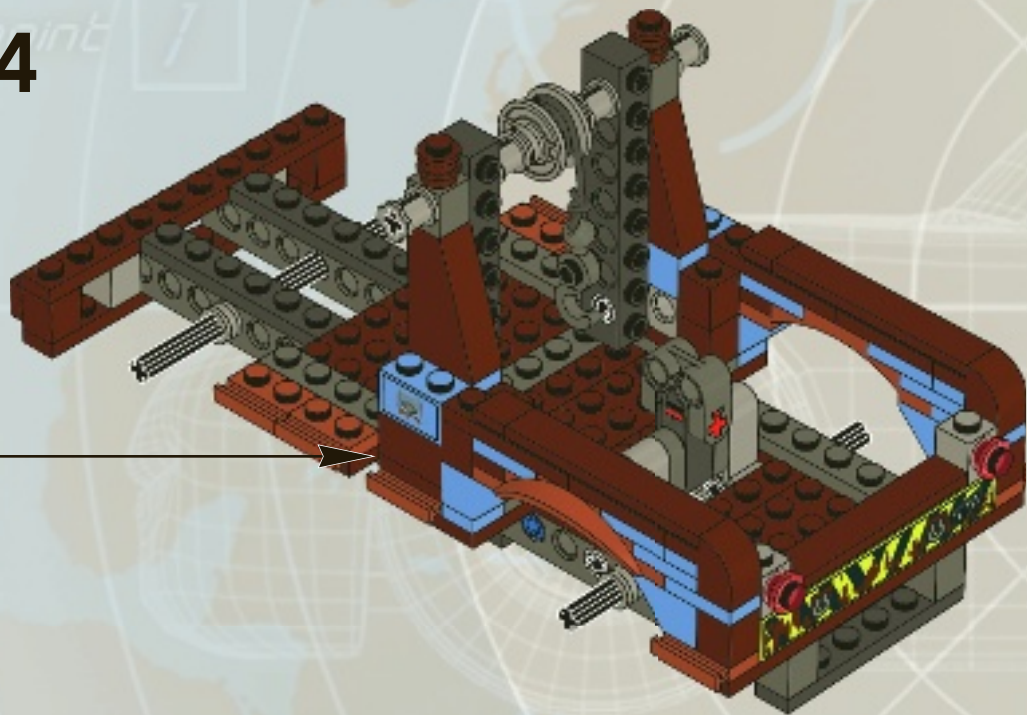

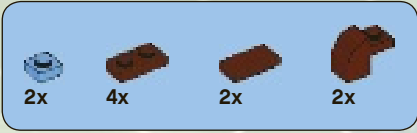

25

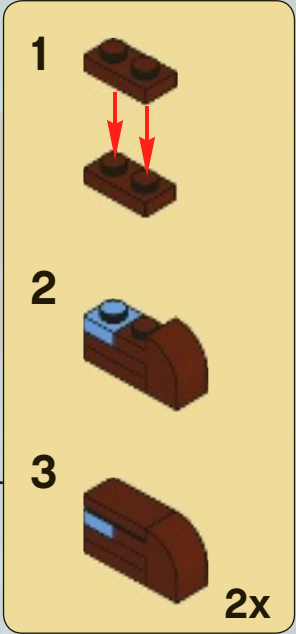
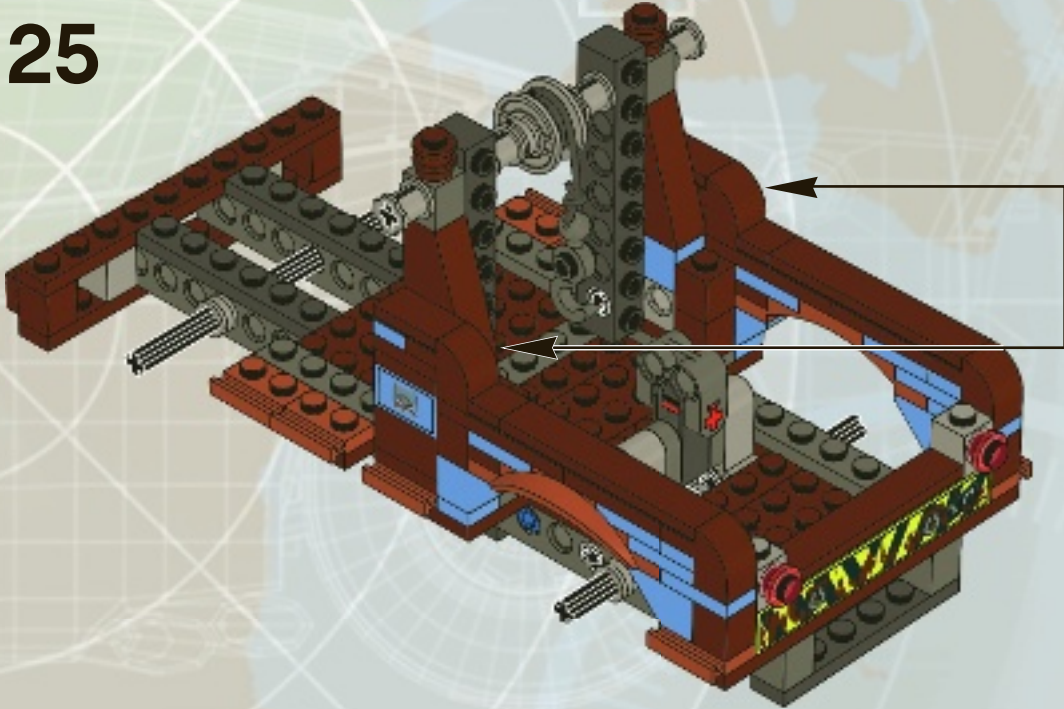

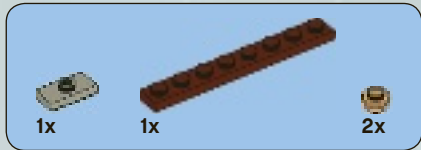

26

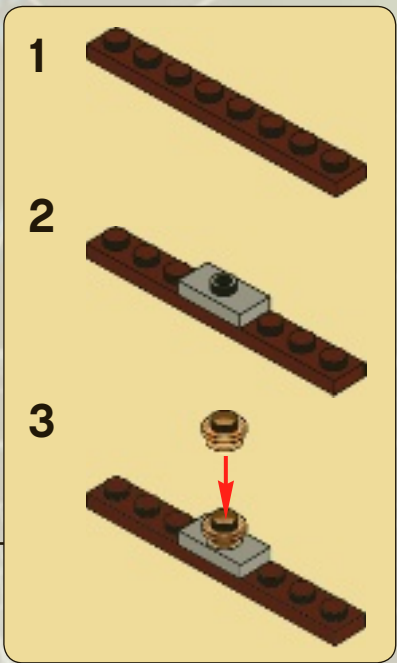
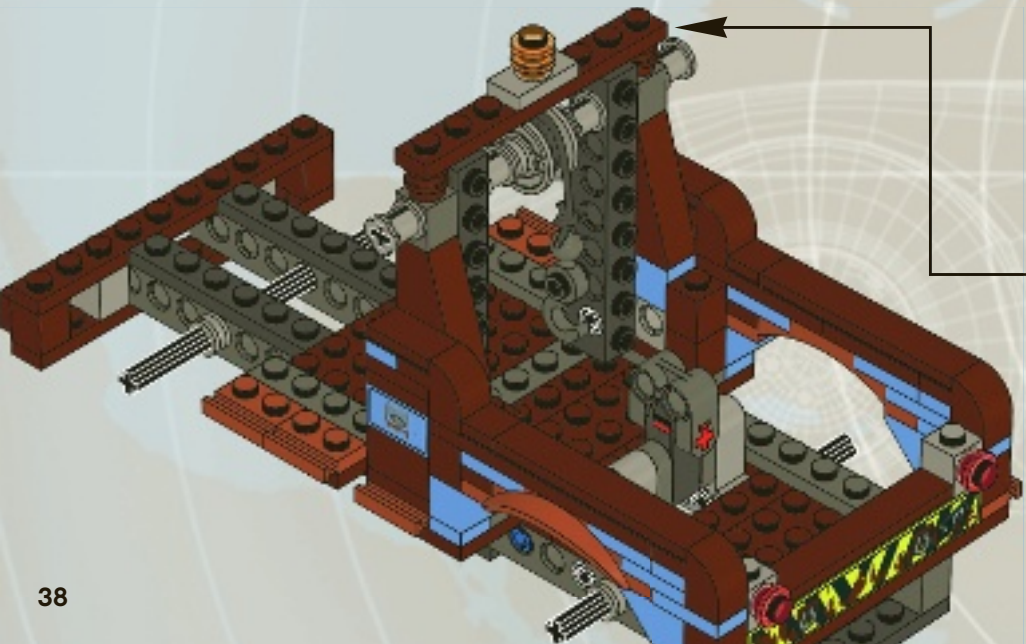



target  
acquired

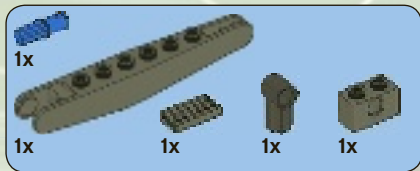

27

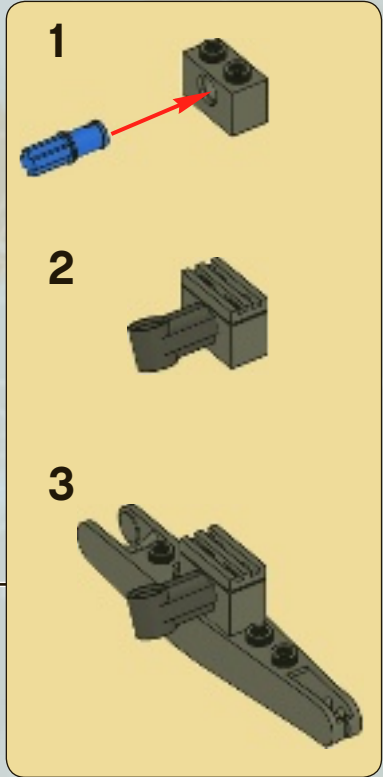
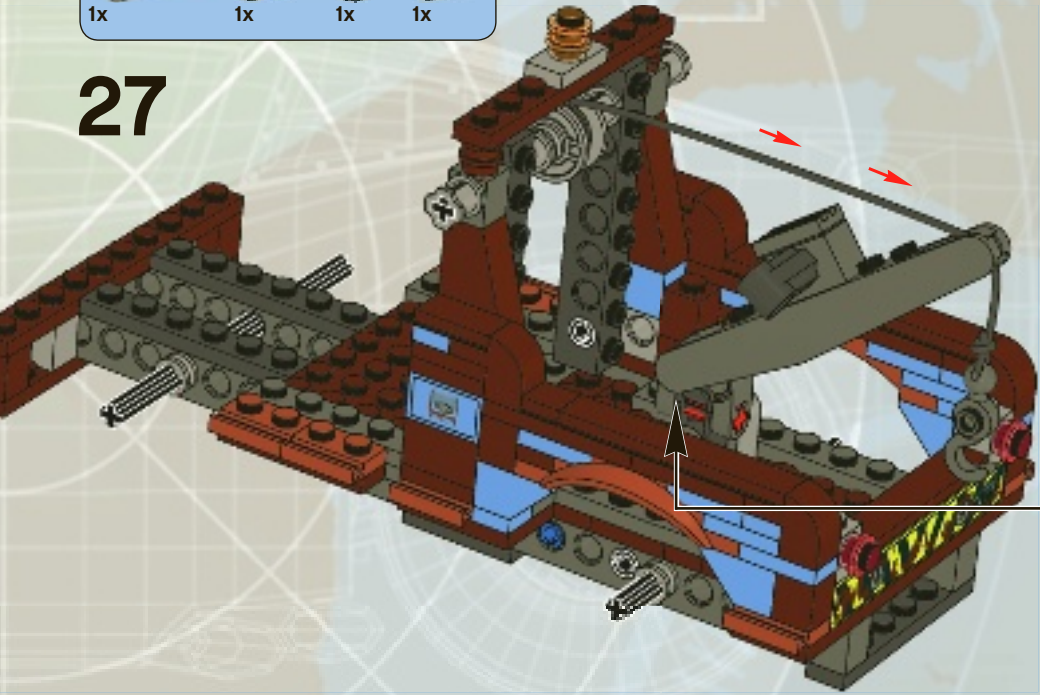

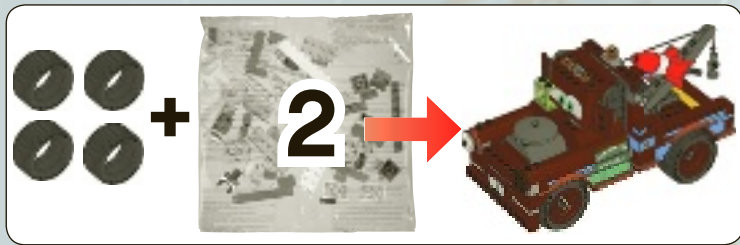

28

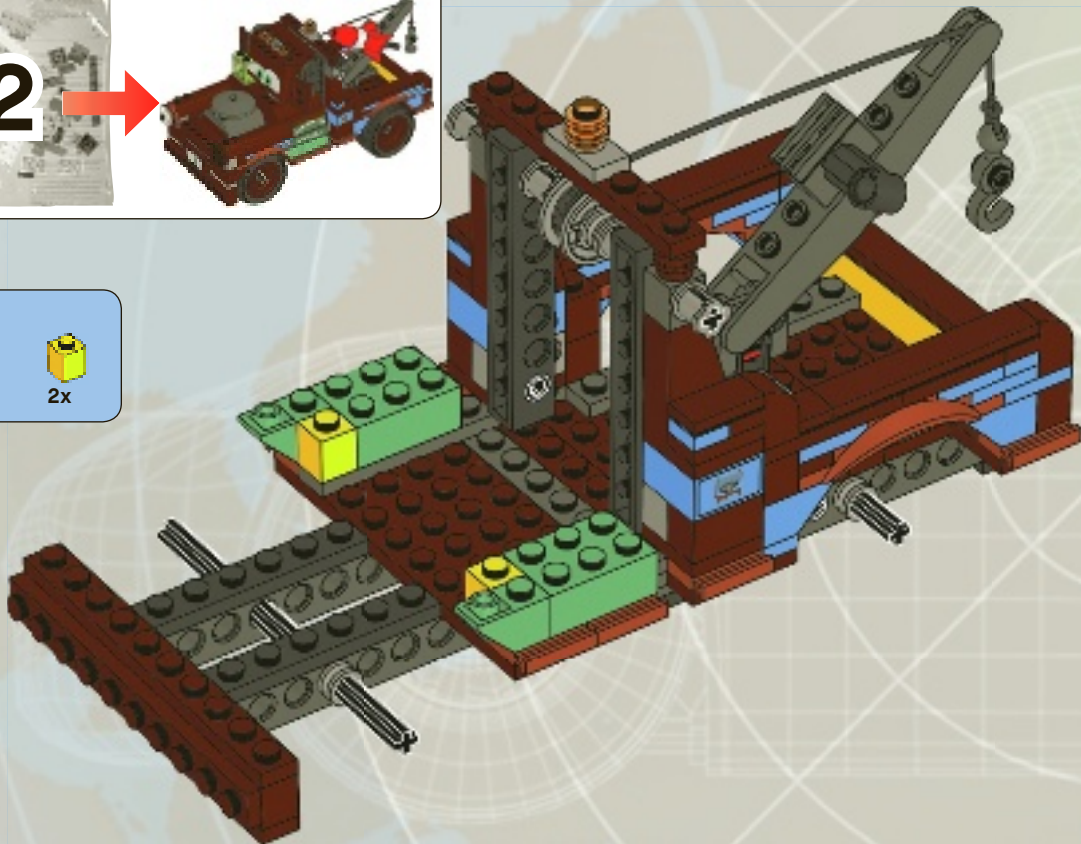

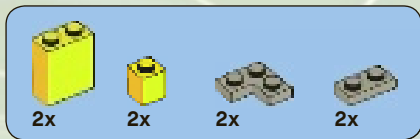

29

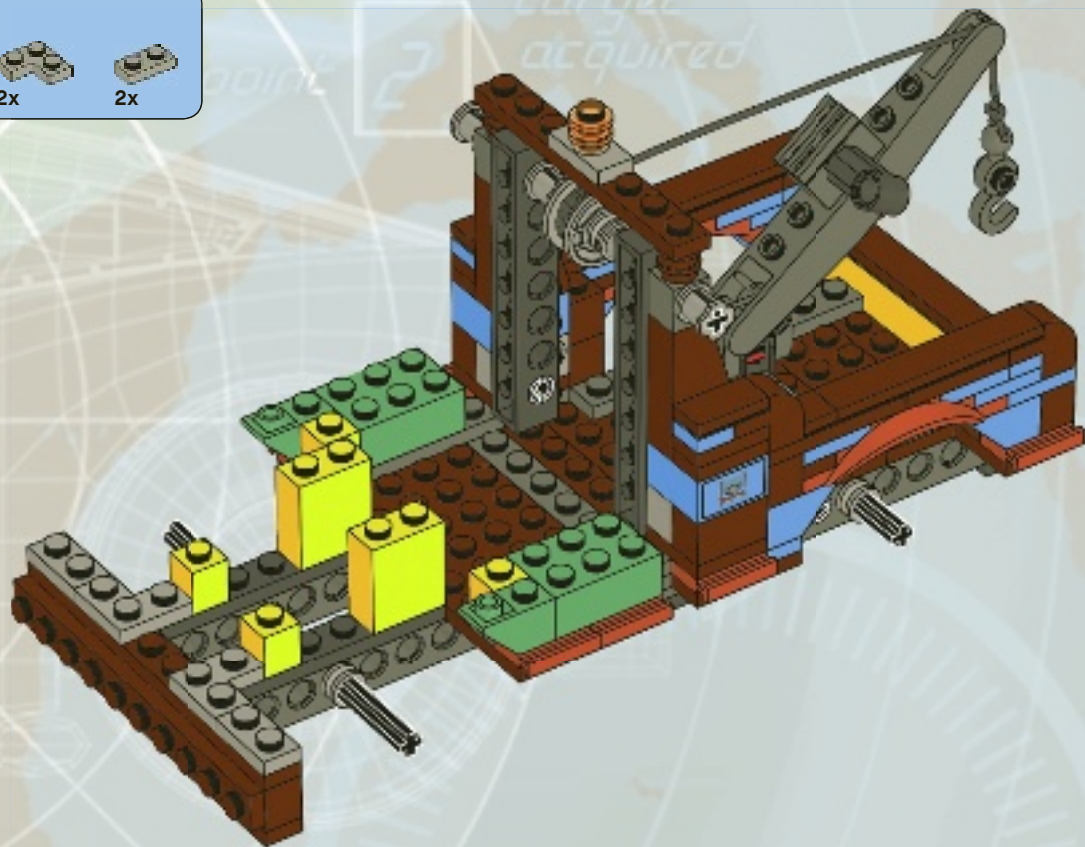



2x



4x

30

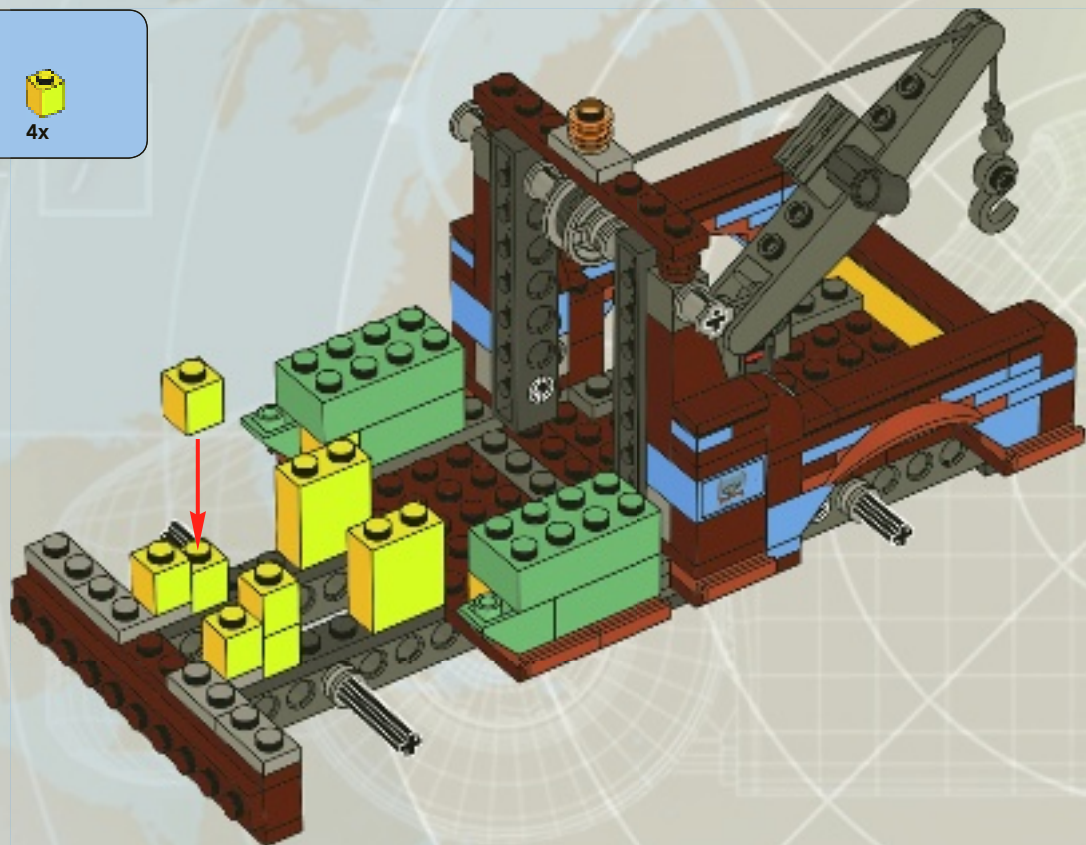





31

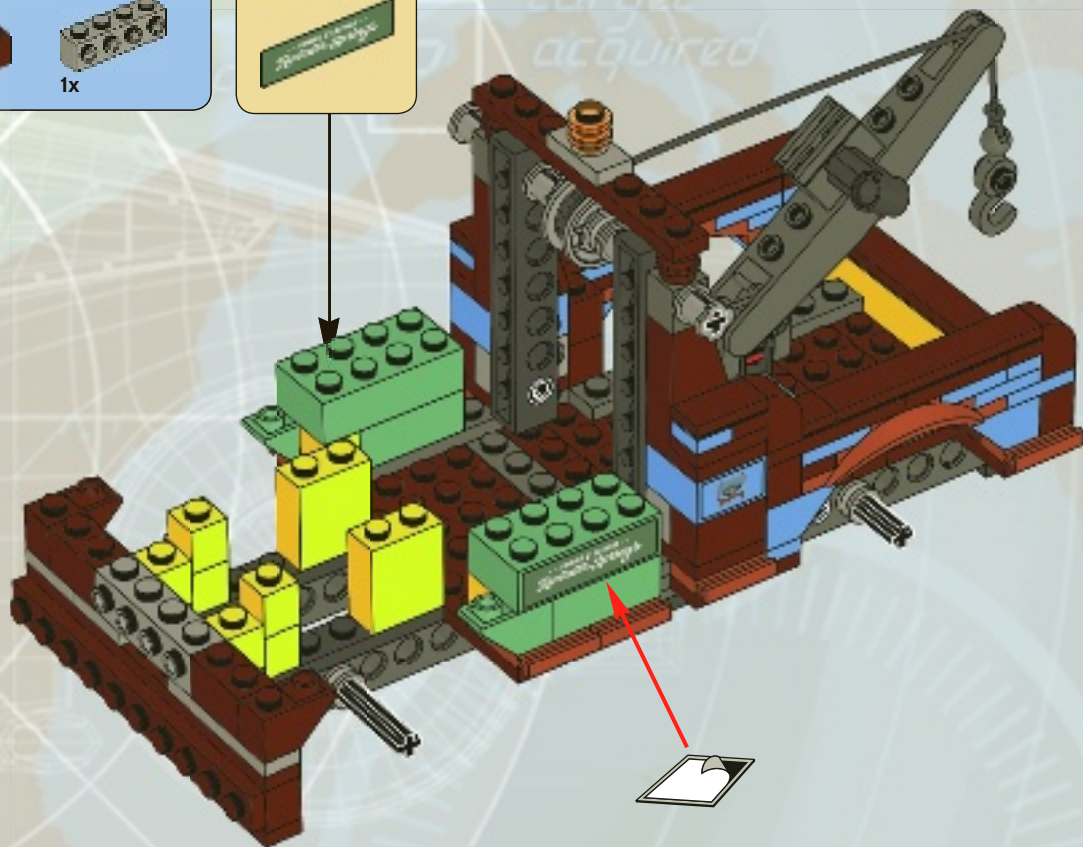



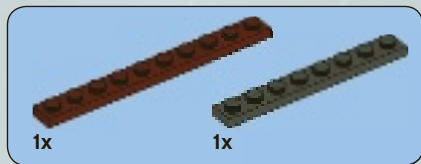

32

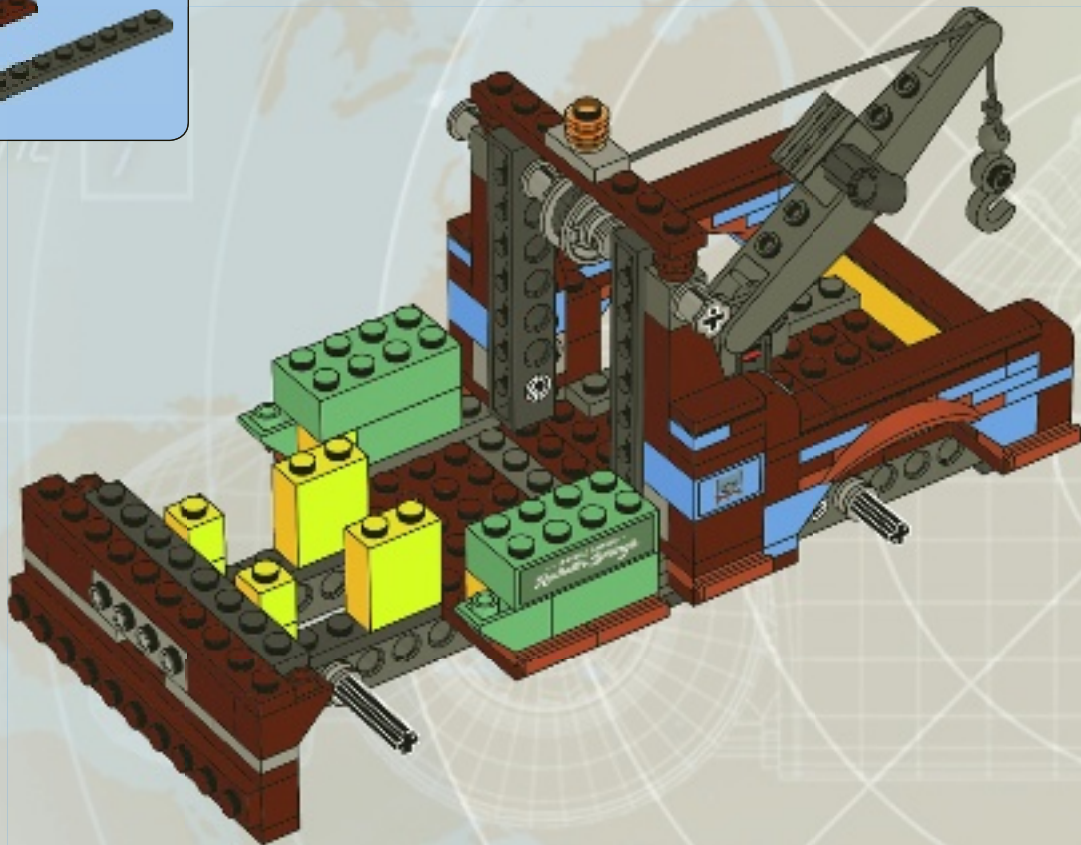

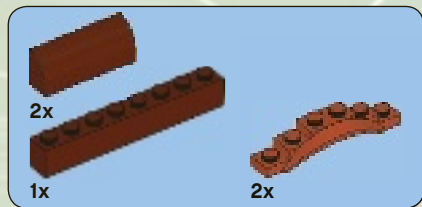

33

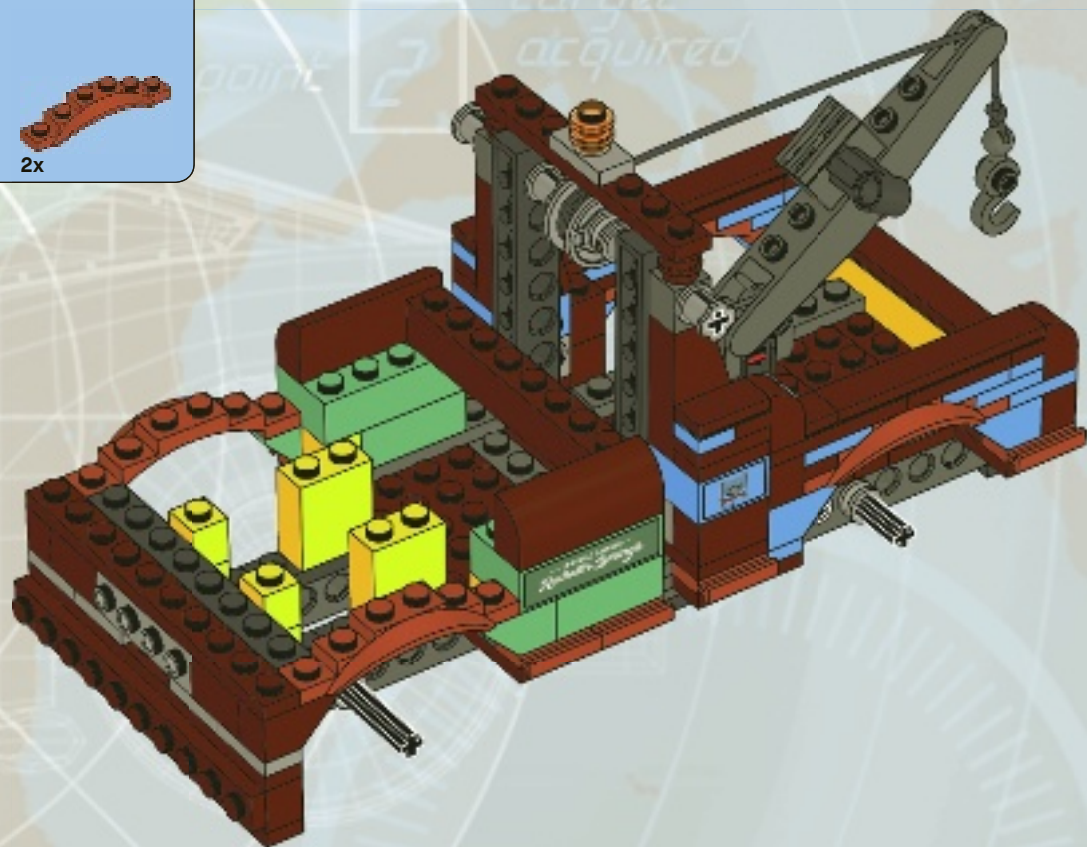



34

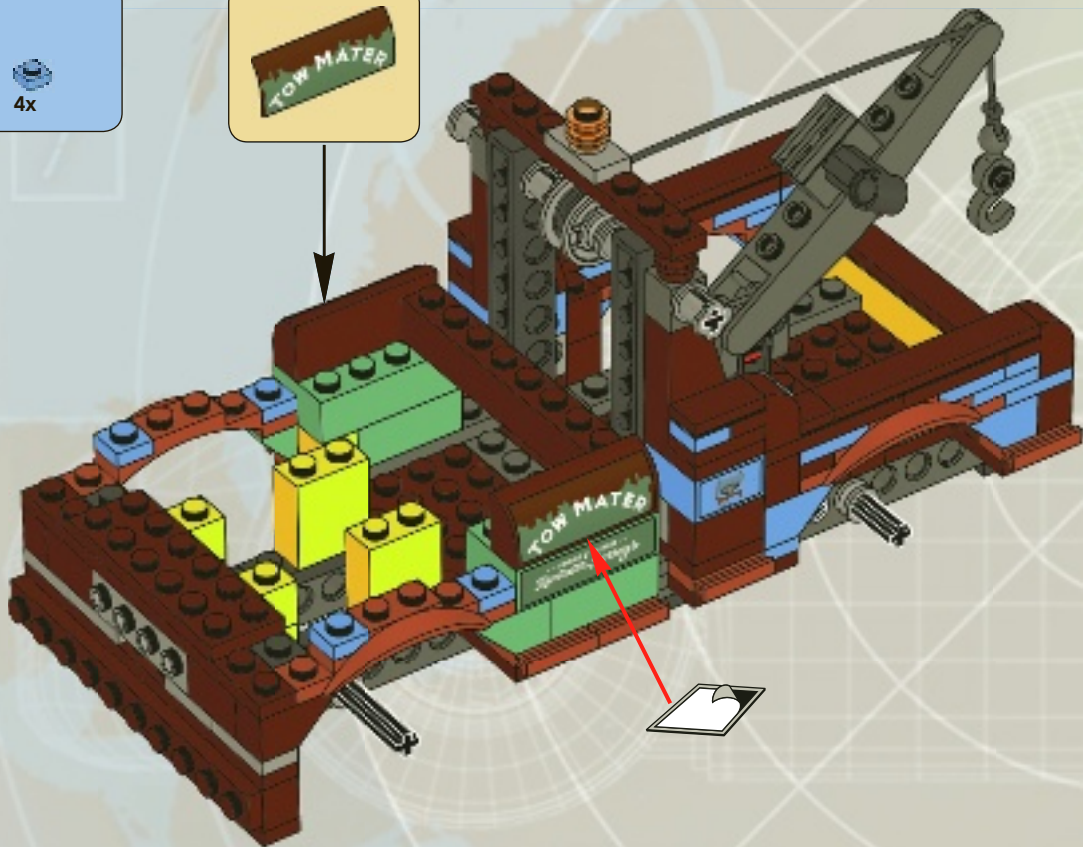

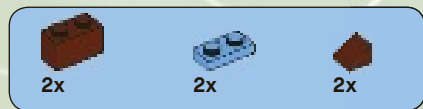

35





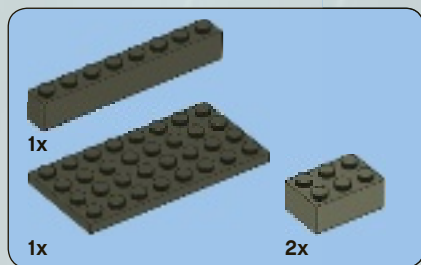

36

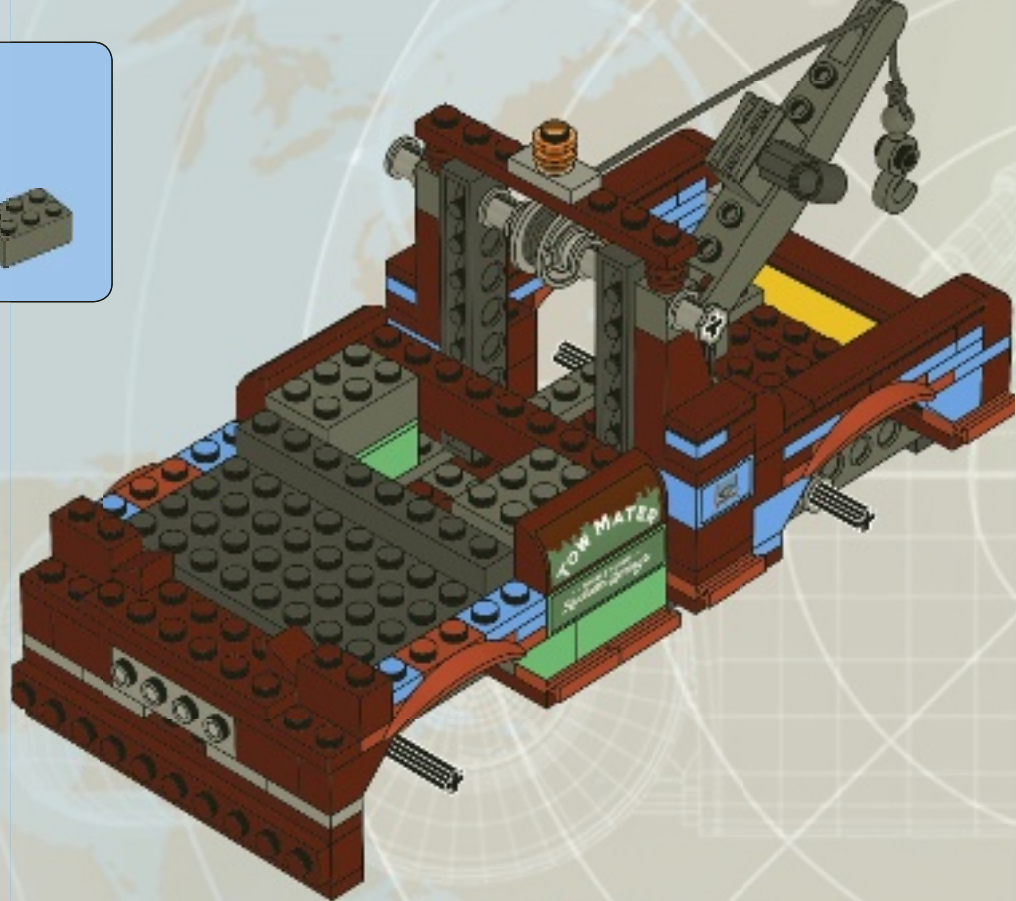





2x



4x

37

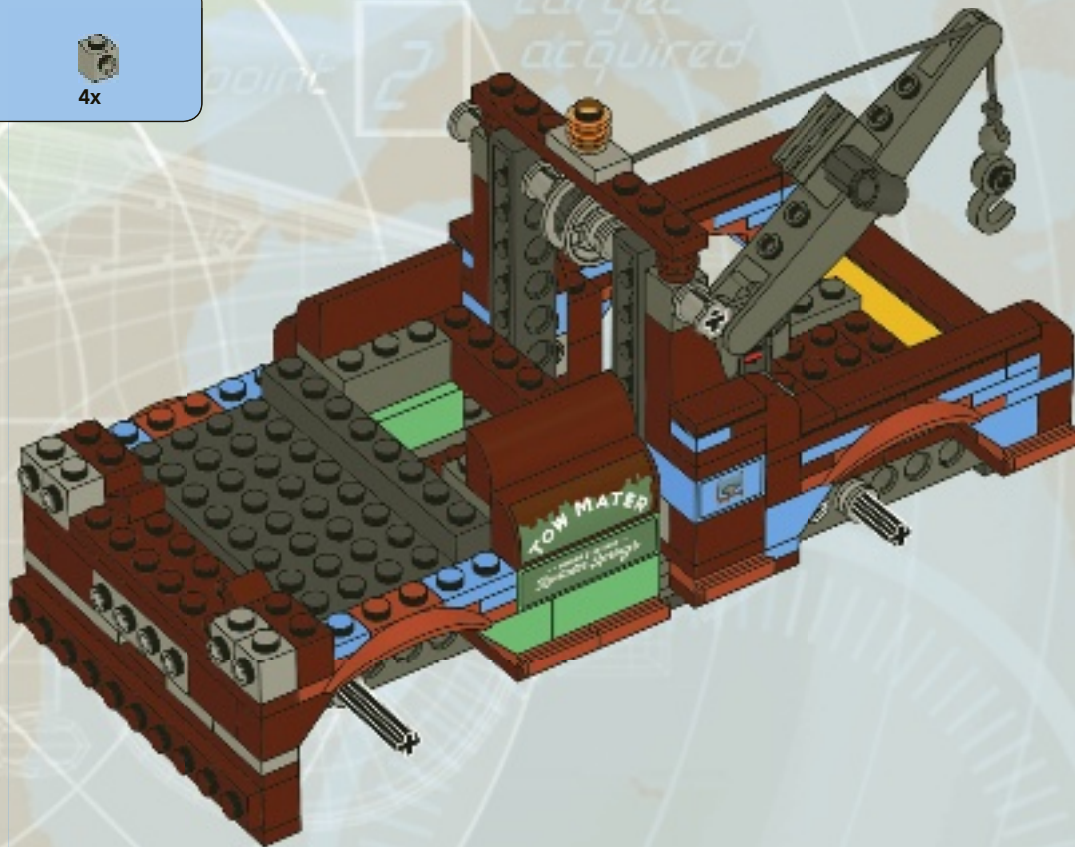

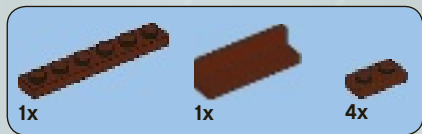

38

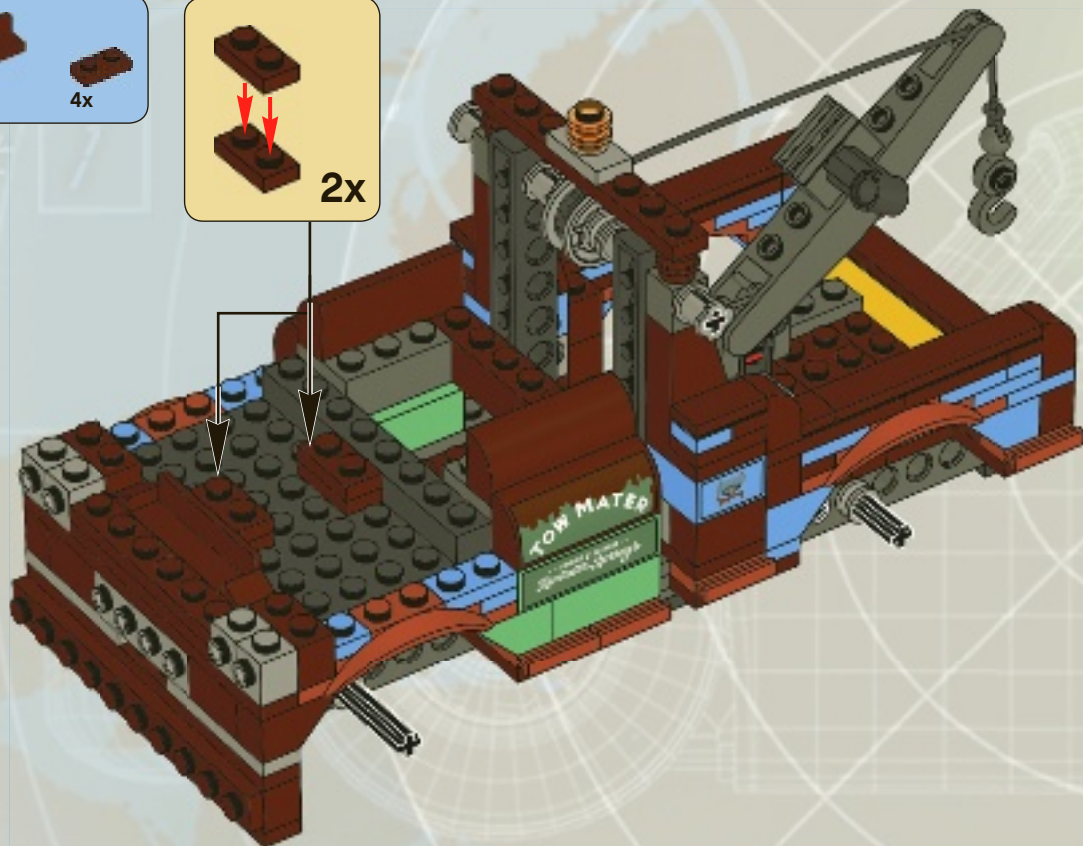
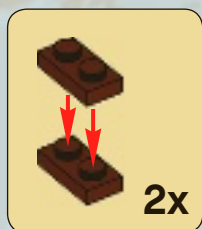

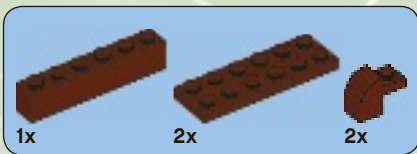

39

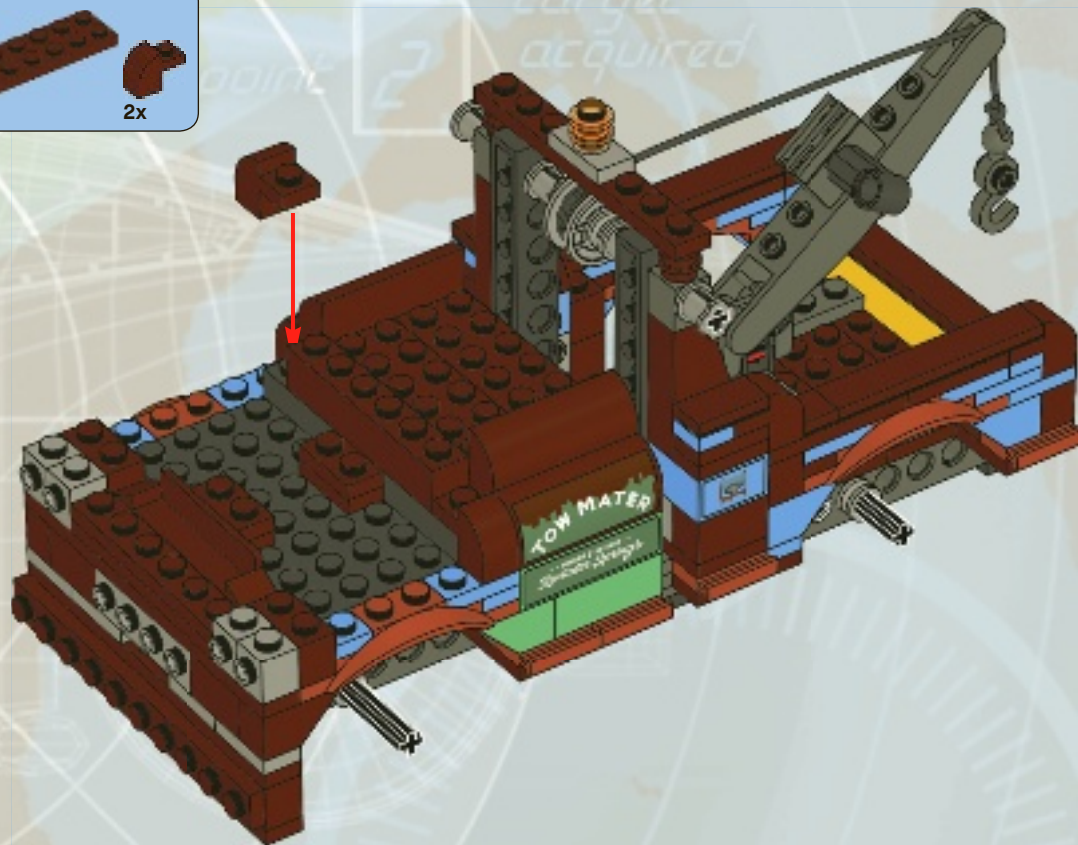



2x



2x

40

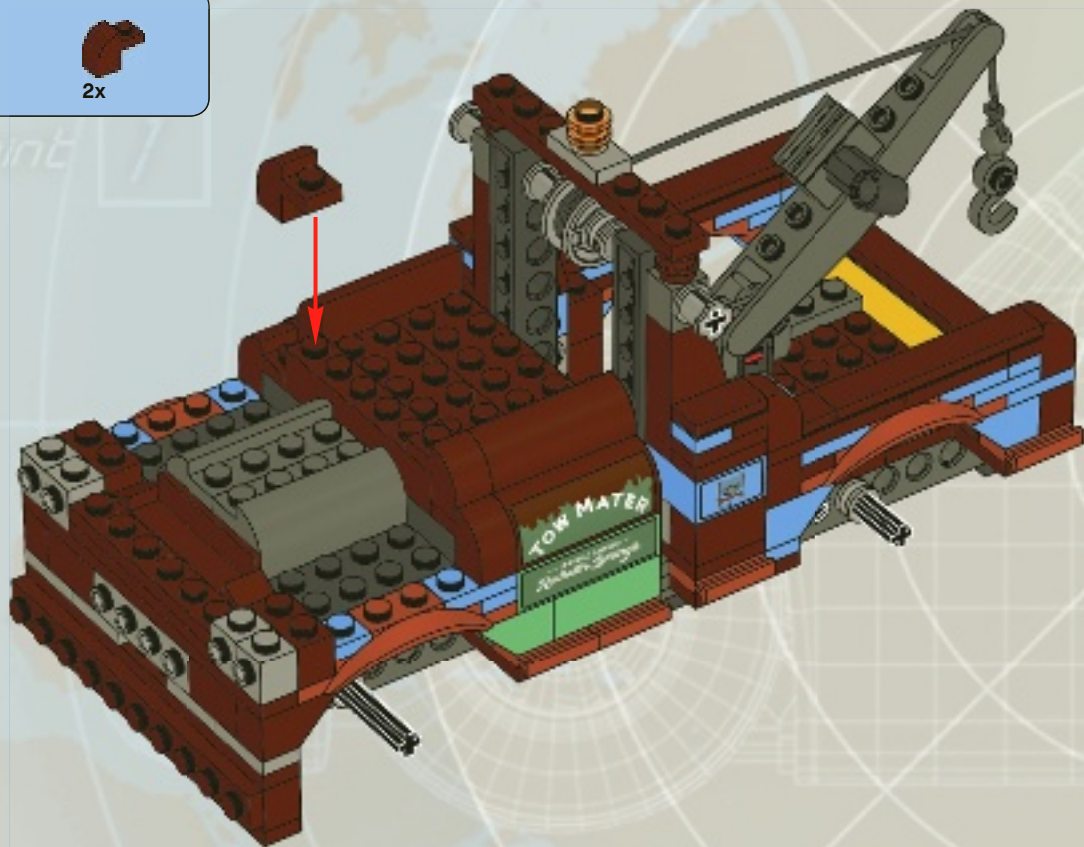





41

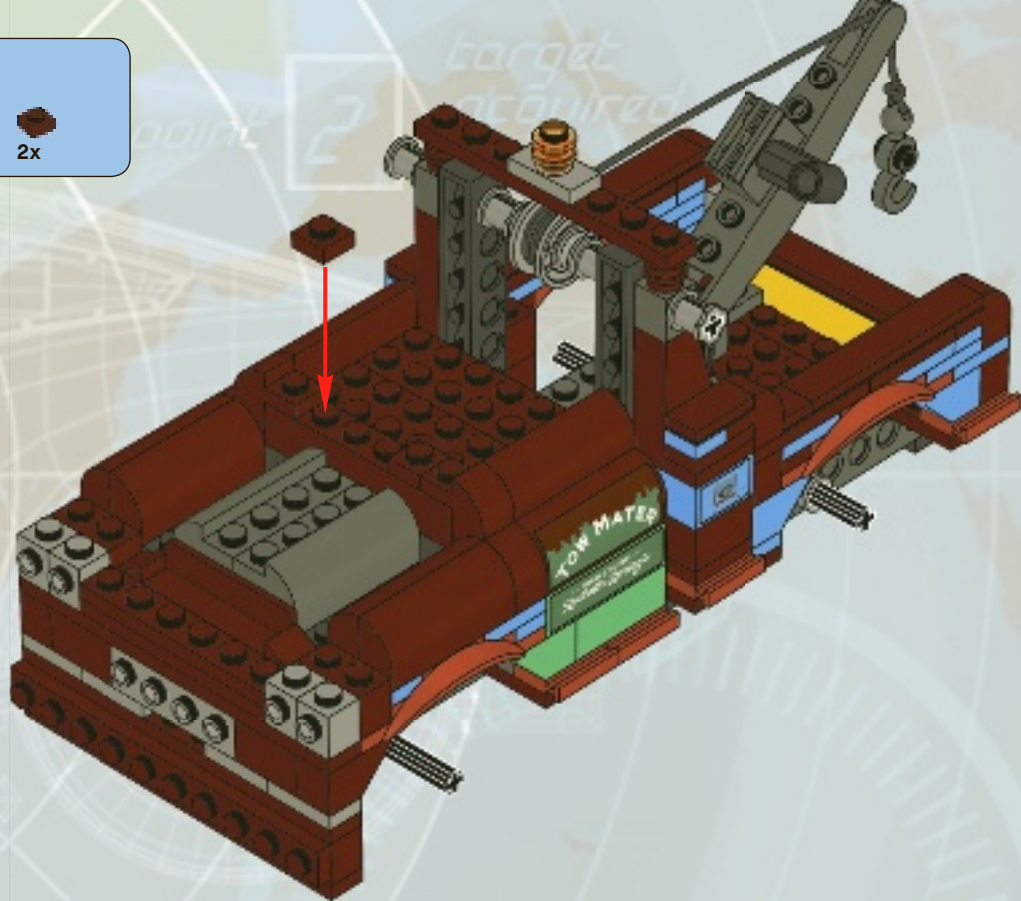



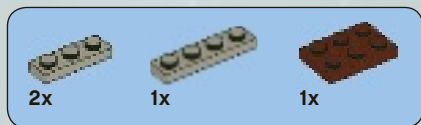

42

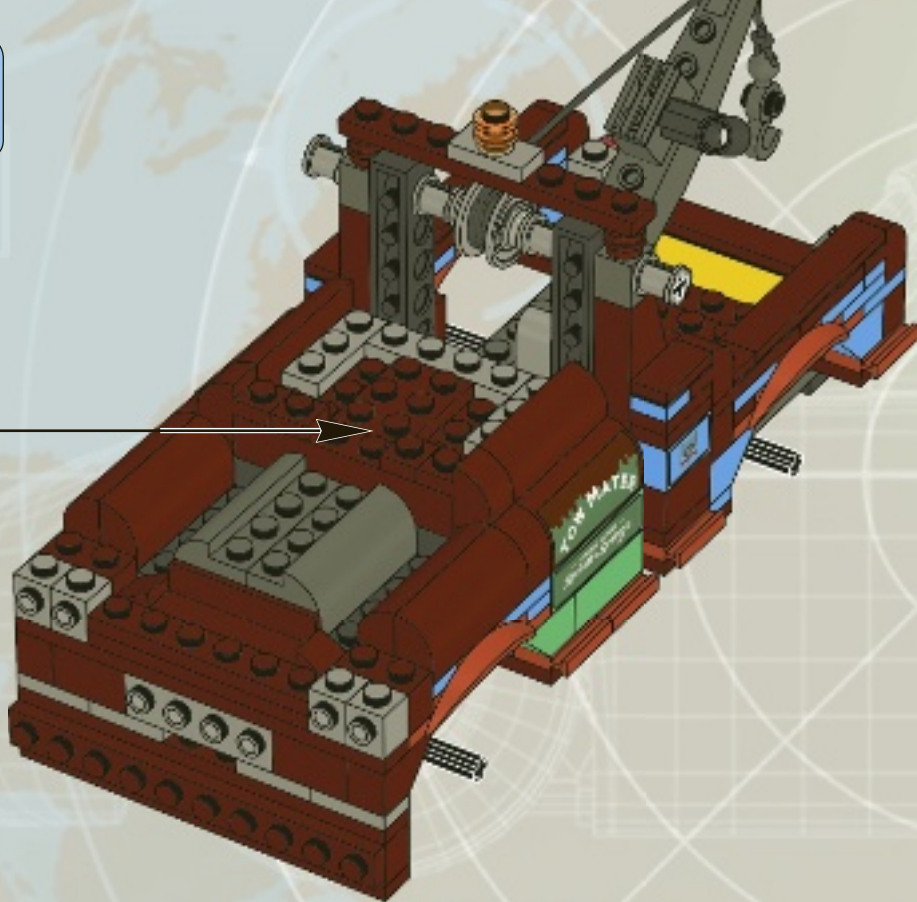



2x



2x

# 43

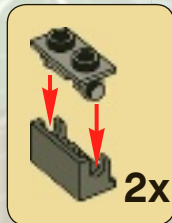

2x



target  
achieved

point 2

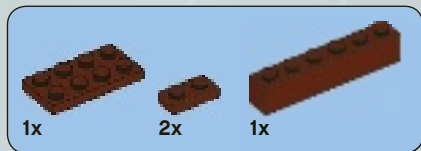

44





45

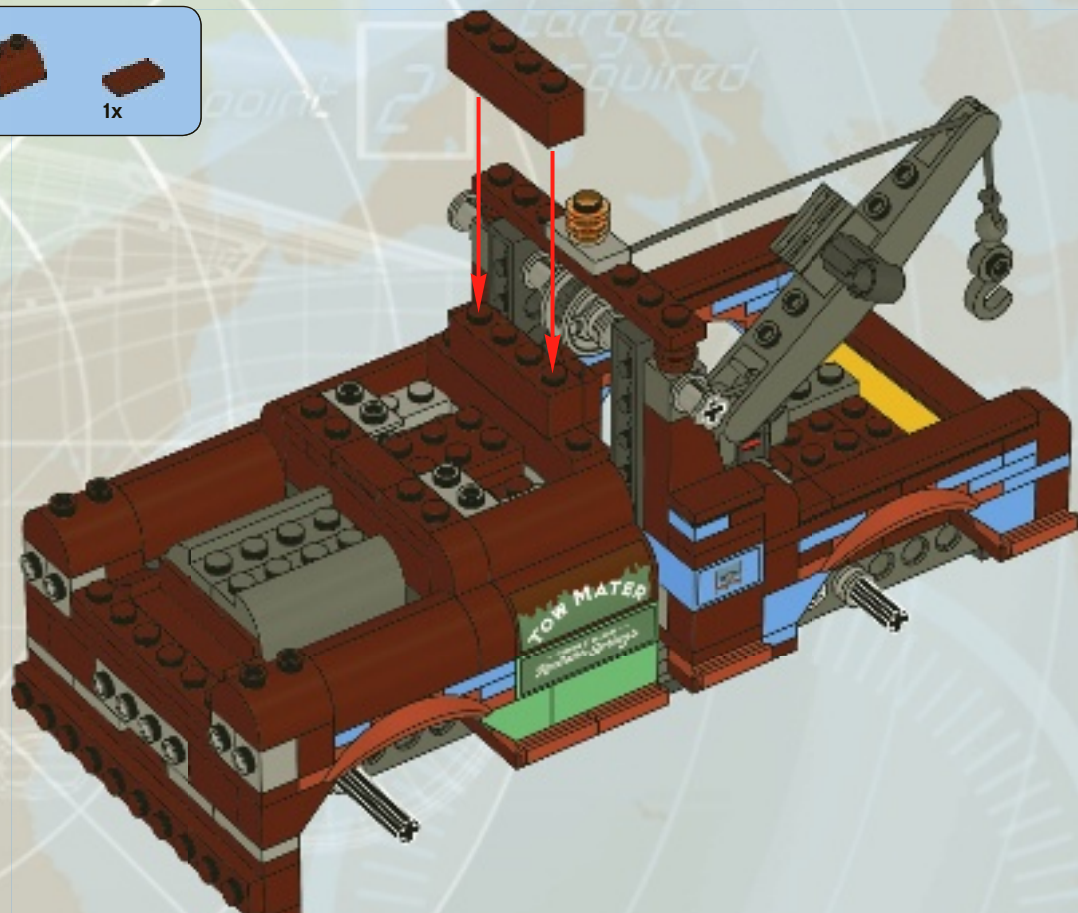





4x



1x



1x

# 46





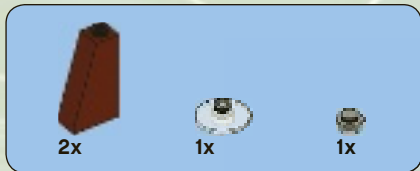

47

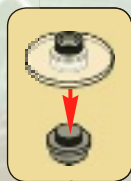



1x



1x

48





49





1x



1x

50





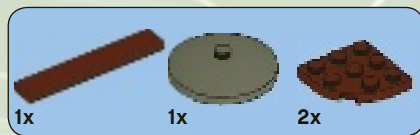

51







52



target  
acquired

point 2



# 53



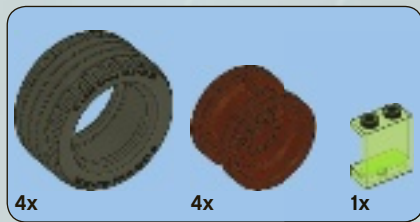

54



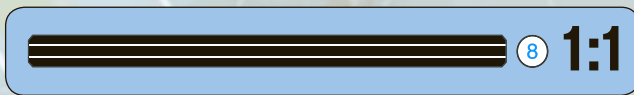
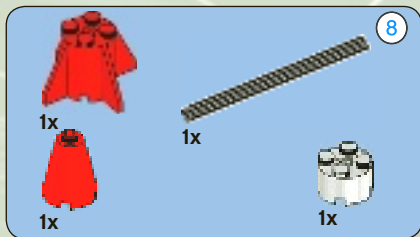

55

1



2



3

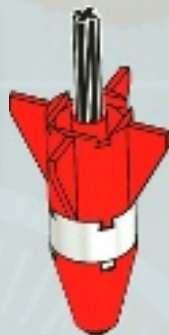





















waypoint 7



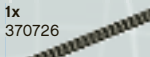











  
 1x  
 614301  
  
 1x  
 4528786  
  
 1x  
 4570282  
  
 1x  
 4142865  
  
 2x  
 4143005  
  
 3x  
 4206482  
  
 8x  
 300524  
  
 2x  
 4121625  
  
 1x  
 300824  
  
 1x  
 4187750

  
 8x  
 4121715  
  
 1x  
 300826  
  
 4x  
 4533771  
  
 4x  
 4184286  
  
 2x  
 370226  
  
 3x  
 366626  
  
 1x  
 346026  
  
 2x  
 302126  
  
 1x  
 4173970

  
 1x  
 4107085  
  
 2x  
 4141349  
  
 1x  
 370526  
  
 1x  
 370726  
  
 3x  
 373726  
  
 1x  
 303526  
  
 8x  
 4616022  
  
 2x  
 4616027  
  
 4x  
 4616054  
  
 2x  
 3005741

  
 2x  
 4201235  
  
 4x  
 4598015  
  
 10x  
 4179826  
  
 10x  
 4179825  
  
 2x  
 4618537  
  
 2x  
 4623295  
  
 2x  
 4623297  
  
 5x  
 4222960  
  
 1x  
 4620598  
  
 8x  
 4558953

  
 2x  
 4211470  
  
 1x  
 4211636  
  
 2x  
 4211541  
  
 2x  
 4211398  
  
 2x  
 4211353  
  
 2x  
 4211429  
  
 1x  
 4211445  
  
 1x  
 4211451  
  
 2x  
 4211525  
  
 1x  
 4521532  
  
 2x  
 4552348

  
 6x  
 4211573  
  
 4x  
 4211622  
  
 4x  
 4221744  
  
 2x  
 4211288  
  
 13x  
 4211150  
  
 3x  
 4211150  
  
 6x  
 4211242  
  
 8x  
 4211149  
  
 2x  
 4211225  
  
 2x  
 4211193  
  
 1x  
 4263776



4x  
4270470



2x  
4211190



1x  
4211186



1x  
4616052



4x  
4211204

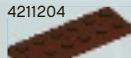

5x  
4211247



3x  
4221590

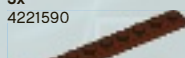

5x  
4223683

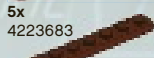

1x  
4216945



2x  
4283660



1x  
4565214



4x  
4618633



8x  
4505458



2x  
4618542



8x  
4618543



2x  
4216695



2x  
4211152



3x  
4211189



2x  
4504376



2x  
4211222



2x  
4121124

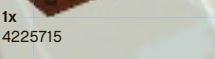

1x  
4225715



2x  
4211257

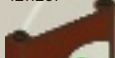

1x  
4616040



4x  
4216581



2x  
4210639



1x  
4211111



2x  
4211105



2x  
4210968



1x  
4212529



1x  
4210631



1x  
4223981



2x  
4211066



1x  
4234599



2x  
4210980



4x  
4211137

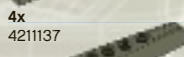

1x  
4620596

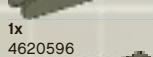

5x  
4210998



1x  
4211065



1x  
4623298

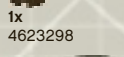

1x  
373726



Customer Service

Kundenservice

Service Consommateurs

Servicio Al Consumidor

[www.lego.com/service](http://www.lego.com/service) or dial



00800 5346 5555 :



1-800-422-5346 :



8484





# WIN!

Go to [www.LEGOsurvey.com/product](http://www.LEGOsurvey.com/product) to fill out a survey for a chance to win a cool LEGO® Product.

No purchase necessary.

Open to all residents where not prohibited.



## [www.LEGOsurvey.com/product](http://www.LEGOsurvey.com/product)

### GEWINNE!

Nimm an der Umfrage auf [www.LEGOsurvey.com/product](http://www.LEGOsurvey.com/product) teil und hab die Chance ein cooles LEGO® Produkt zu gewinnen!

Die Teilnahme am Gewinnspiel führt zu keinerlei Kaufverpflichtungen. Teilnahme in allen nicht ausgeschlossenen Ländern möglich.

### WIN!

Ga naar [www.LEGOsurvey.com/product](http://www.LEGOsurvey.com/product), vul een enquêteformulier in en maak kans op een cool LEGO® product.

Geen aankoopverplichting, iedereen mag deelnemen, uitgezonderd ingezetenden van landen waar een enquêteverbod geldt.

### GAGNE!

Visite [www.LEGOsurvey.com/product](http://www.LEGOsurvey.com/product) pour répondre à un questionnaire et avoir une chance de gagner un produit LEGO® très cool!

Aucune obligation d'achat. Ouvert à tous les résidents des pays autorisés.

### 当てよう!

[www.LEGOsurvey.com/product](http://www.LEGOsurvey.com/product) にアクセスして、アンケートにご記入ください。当選者にはレゴ®製品を差し上げます。

お買い上げの必要はありません。禁止されていない限り、すべての皆様にご利用いただけます。