



RACERS

8231



1

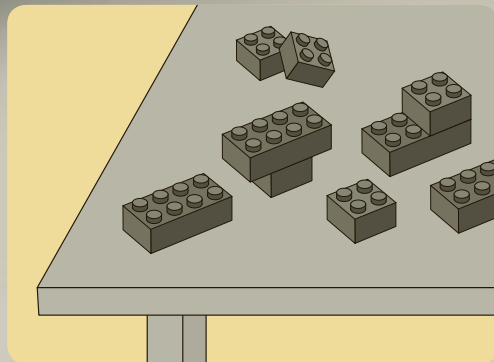
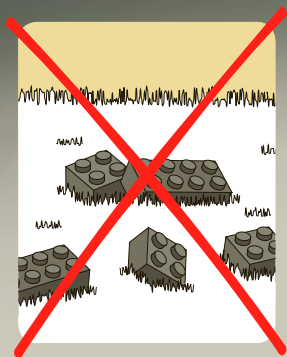

2

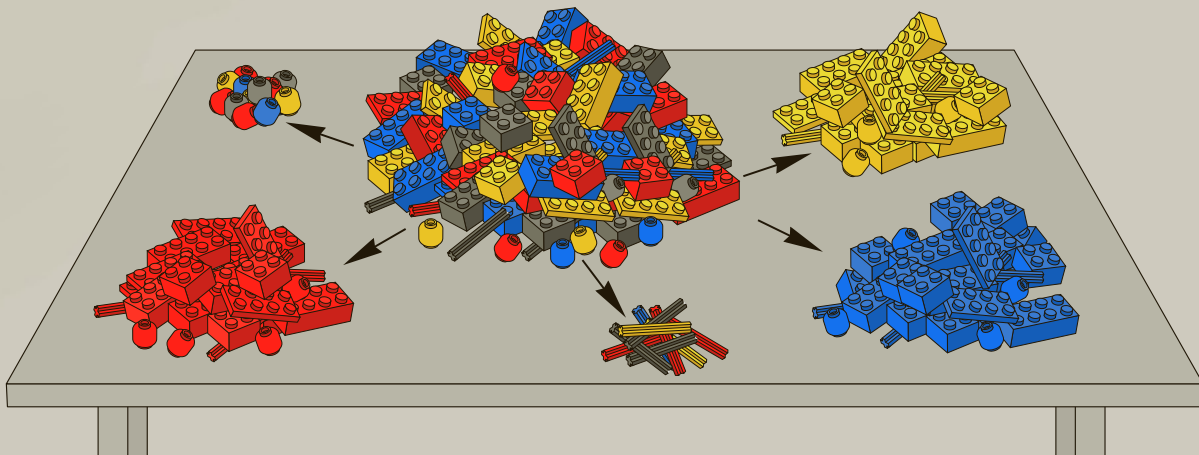

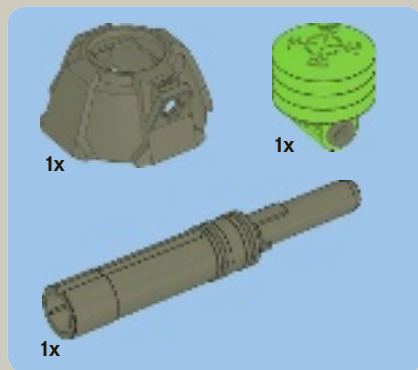

1

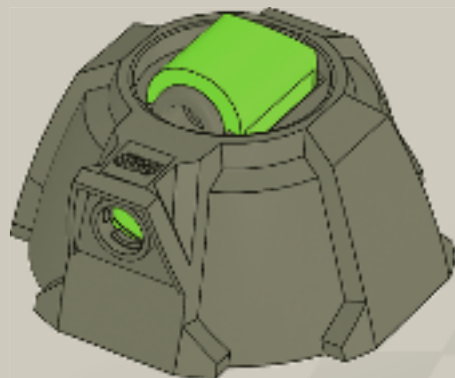

2

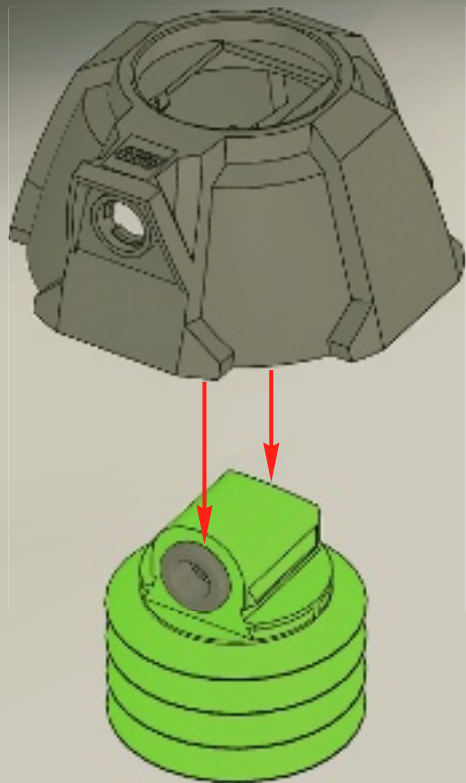

3

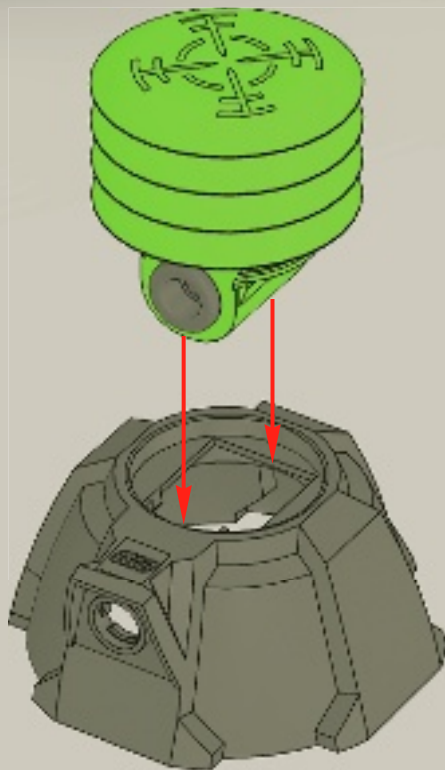

4

4

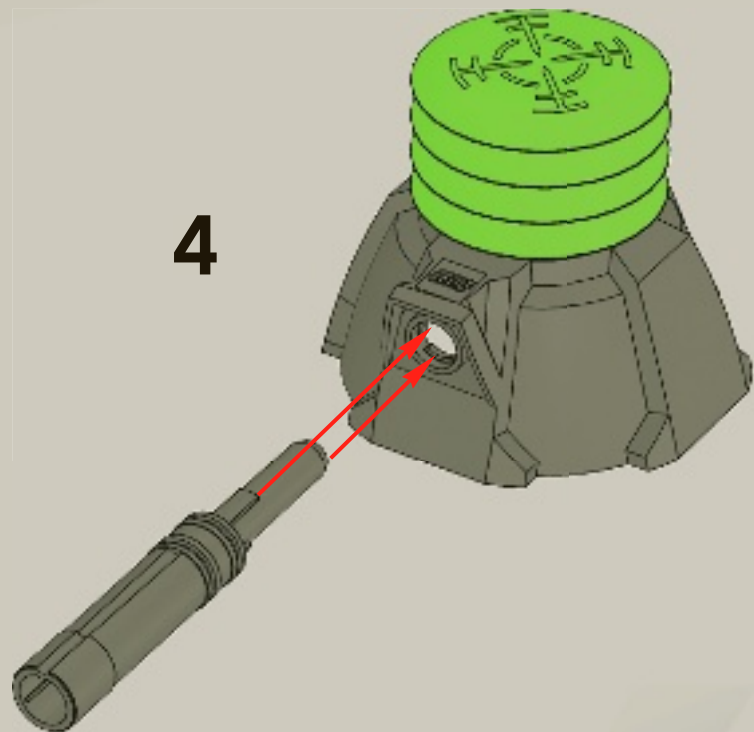

5

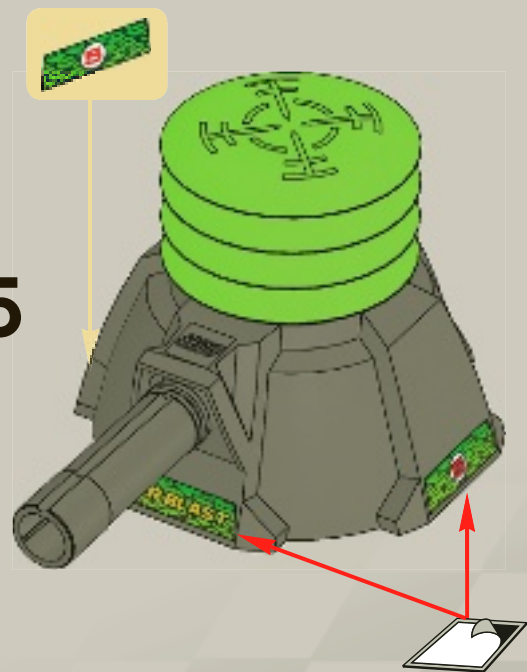



1x

1

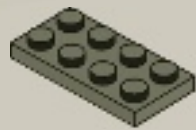

2x

2



6



2x

3

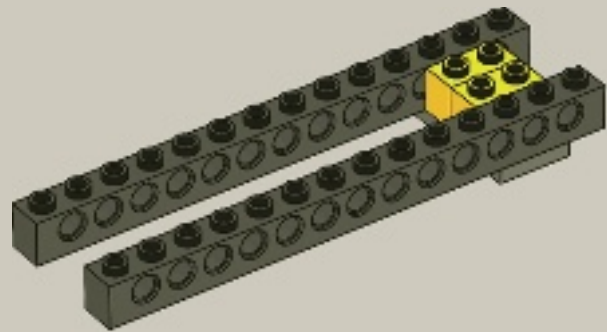



4

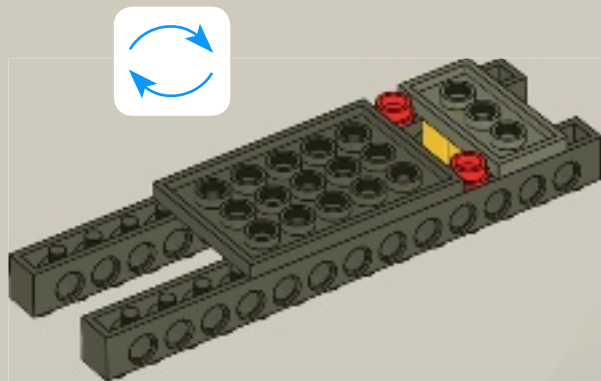

5

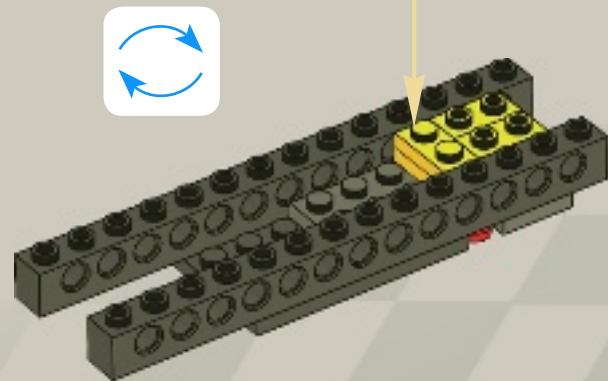
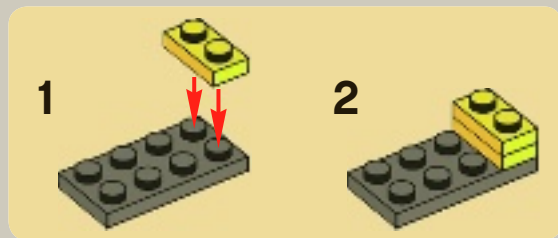

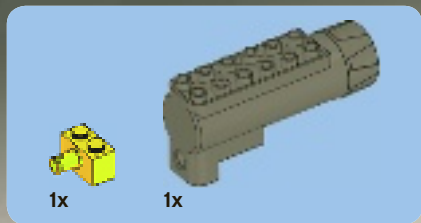

6

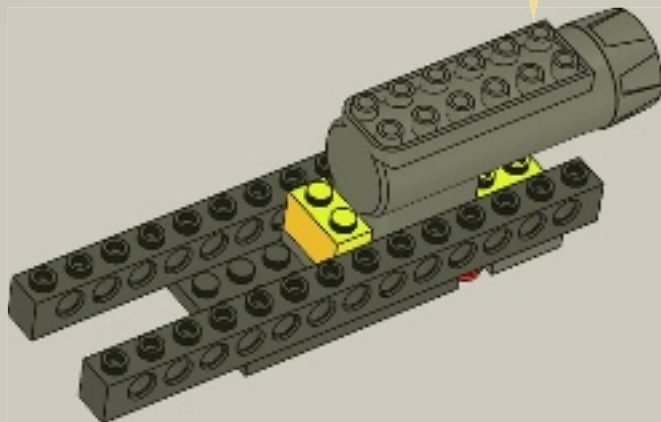
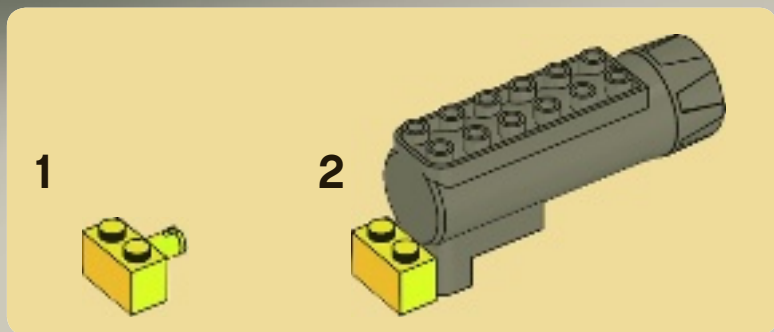



2x



1x

7

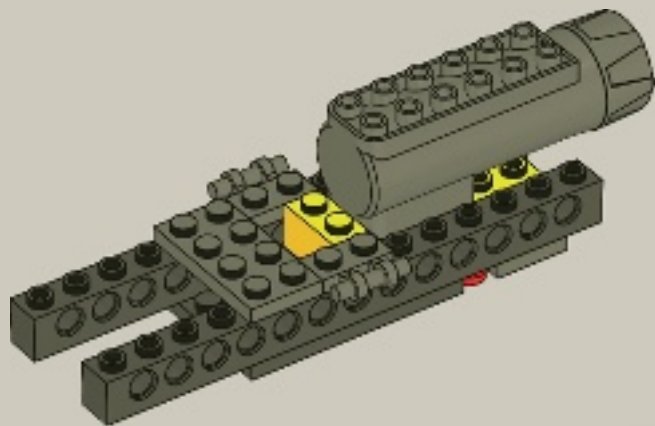

1x

8

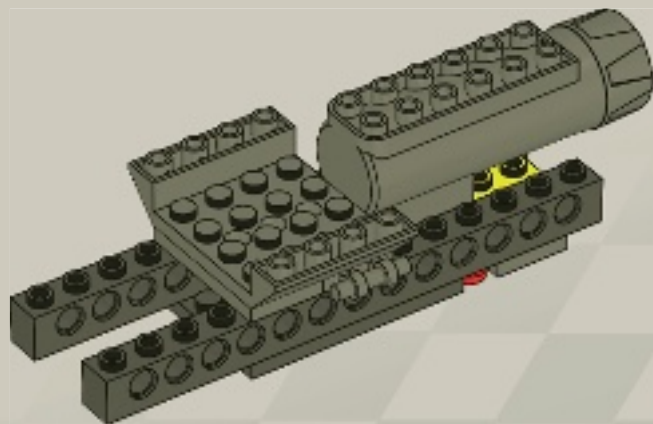



1x



2x

9

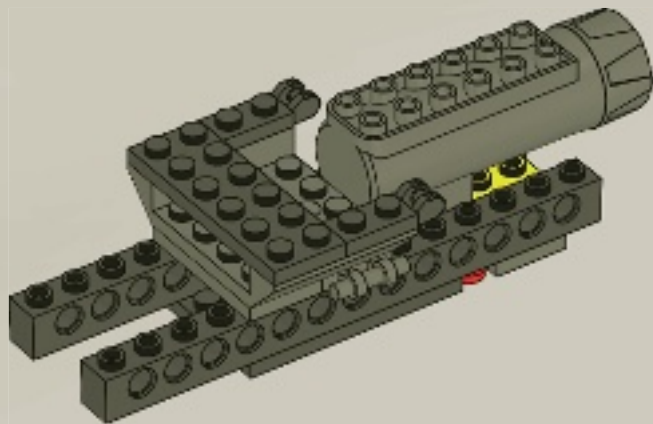

10



2x

8



4x

10



8

1:1

2x

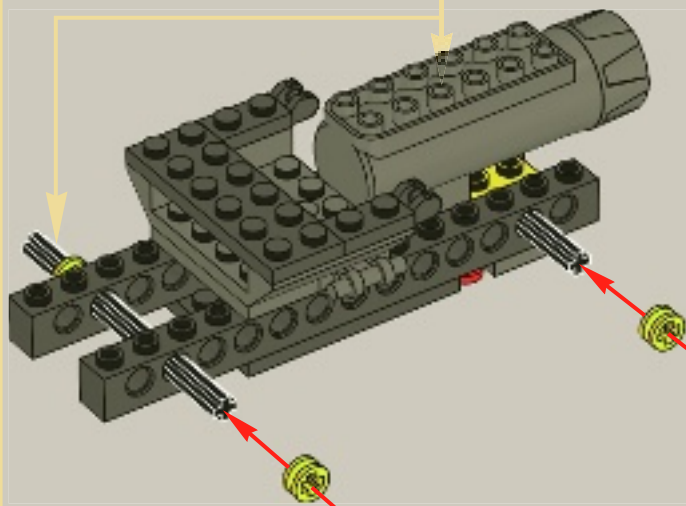



11

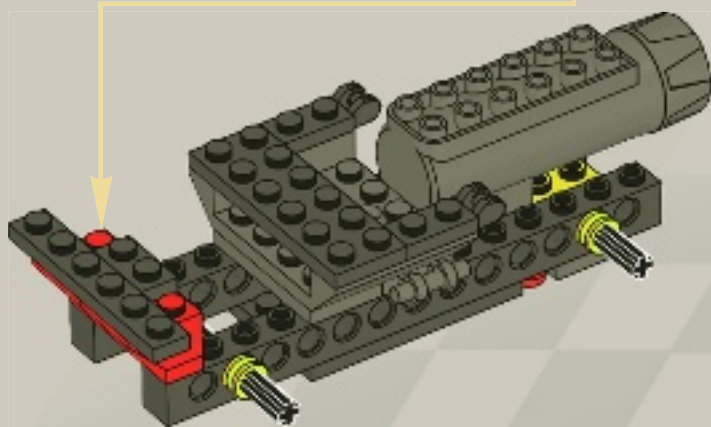
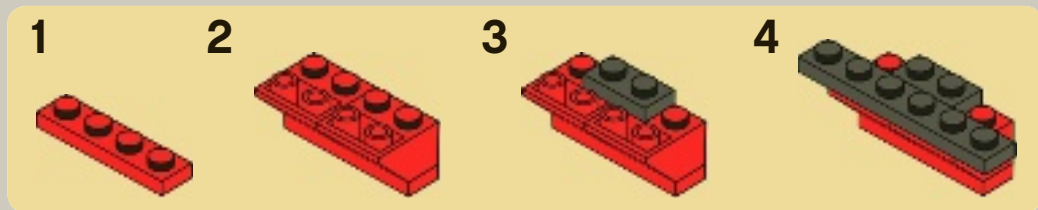



1x



2x

12

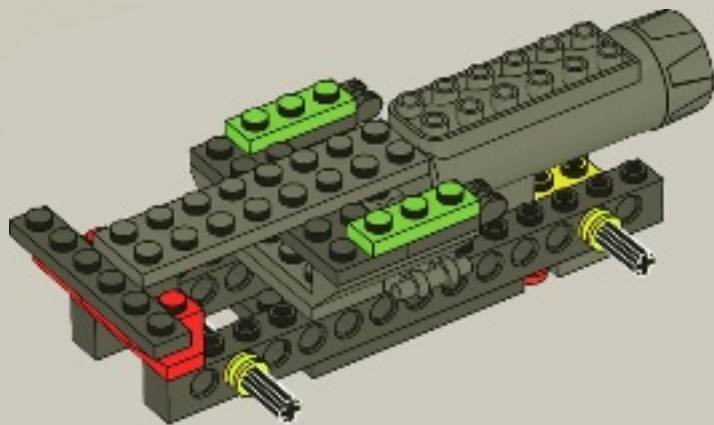



2x

13

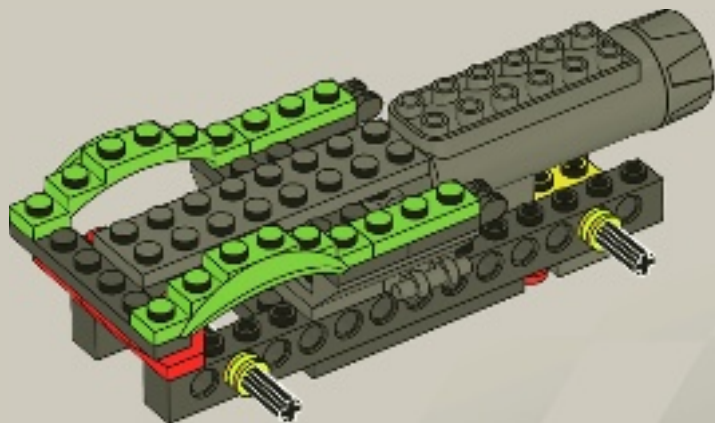



14

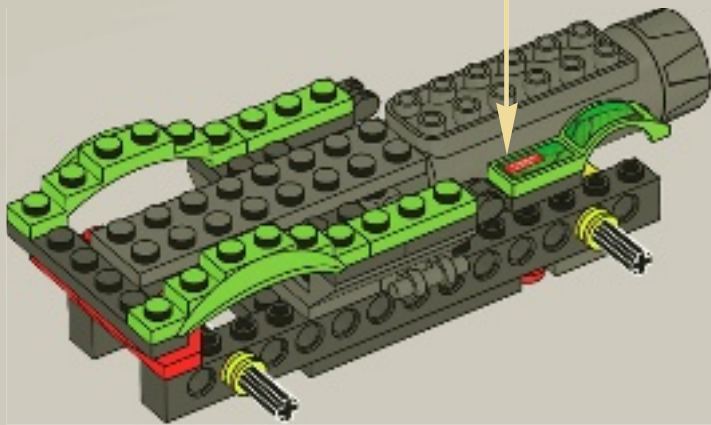



15

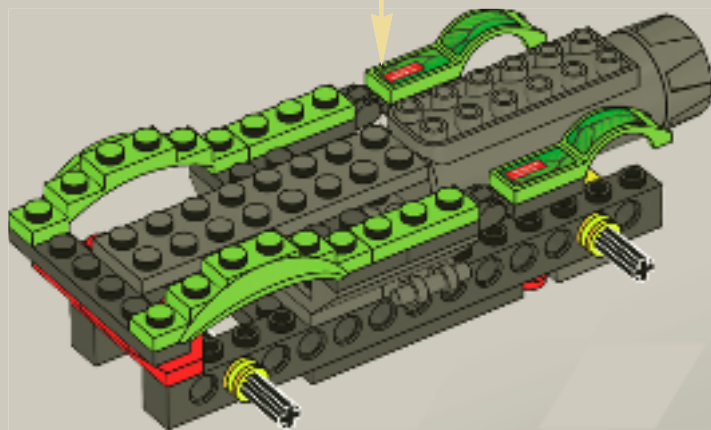
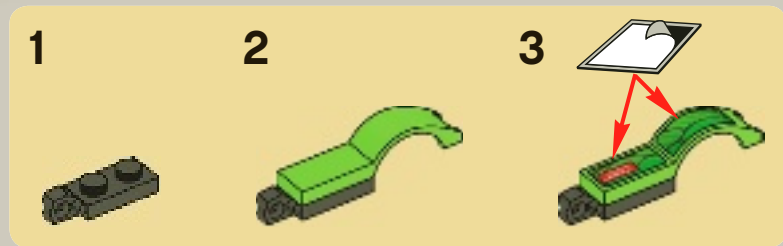

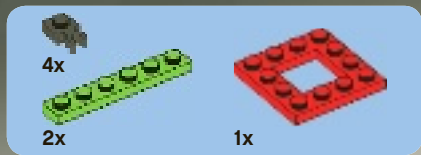

16

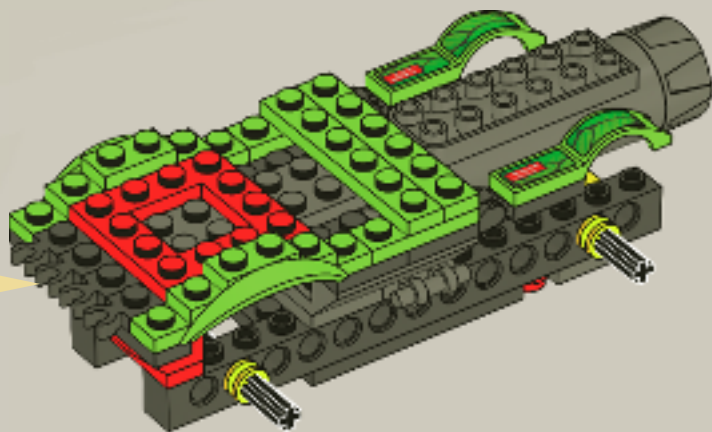
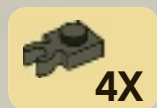



17

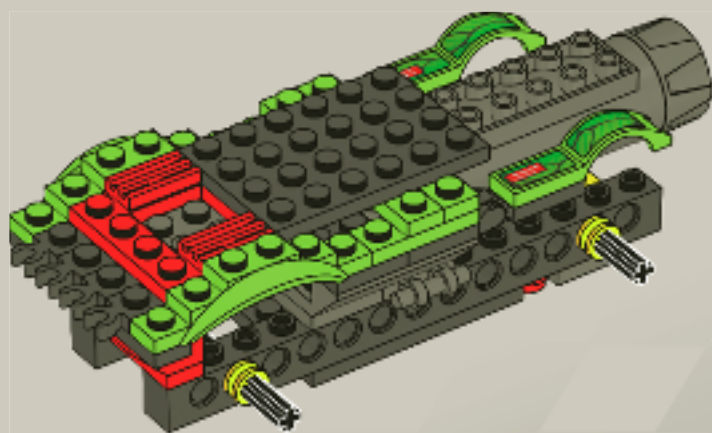



2x



1x

18

1

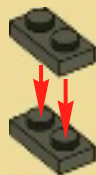

2

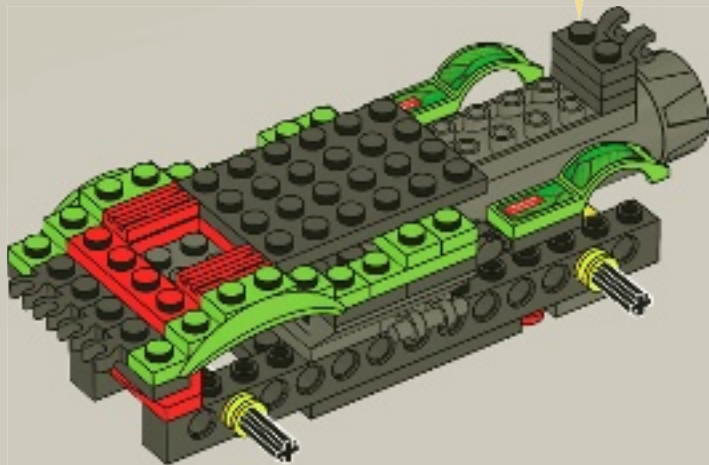



1x



2x



2x

19

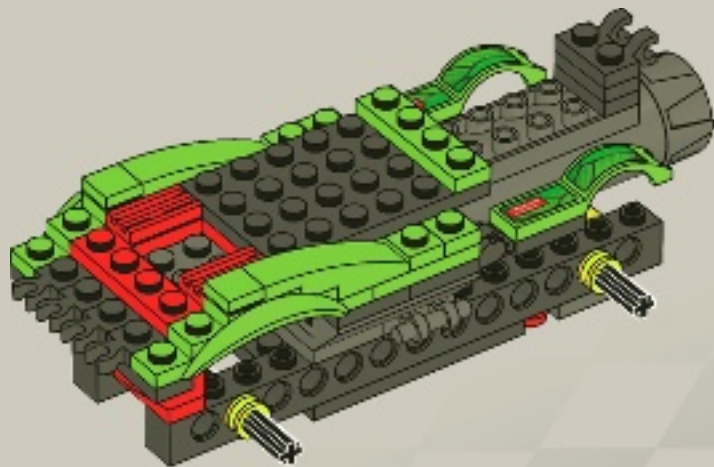



2x



2x



2x

20

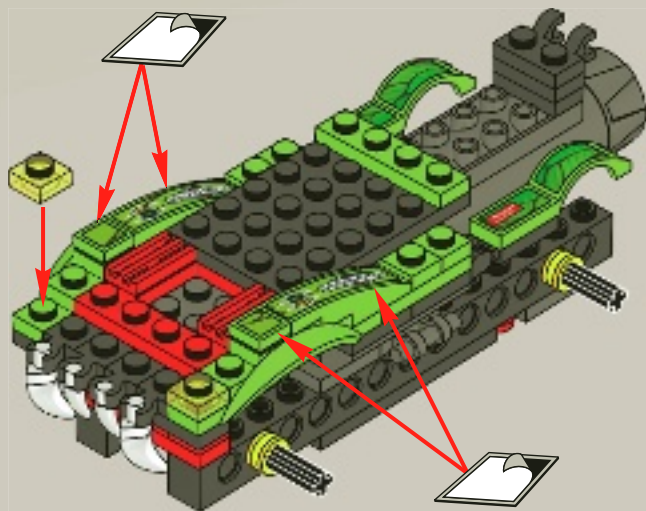

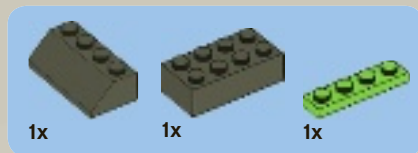

21

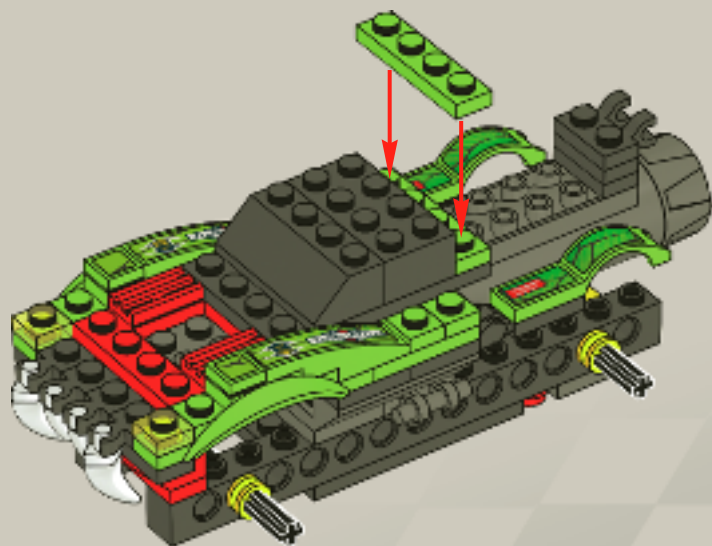



2x



1x

22

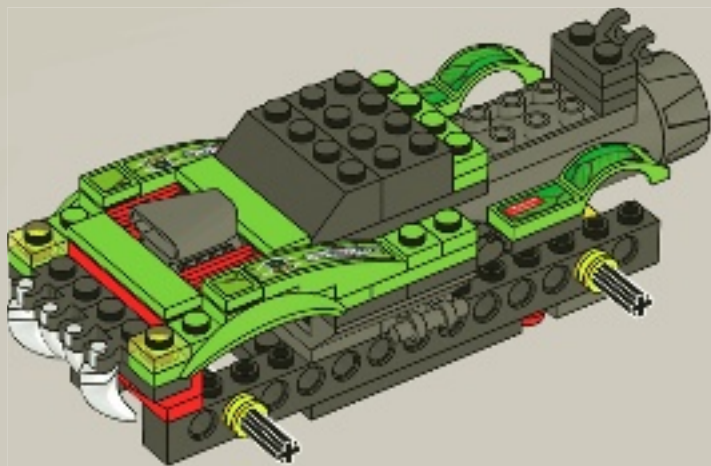



2x

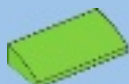

1x

23

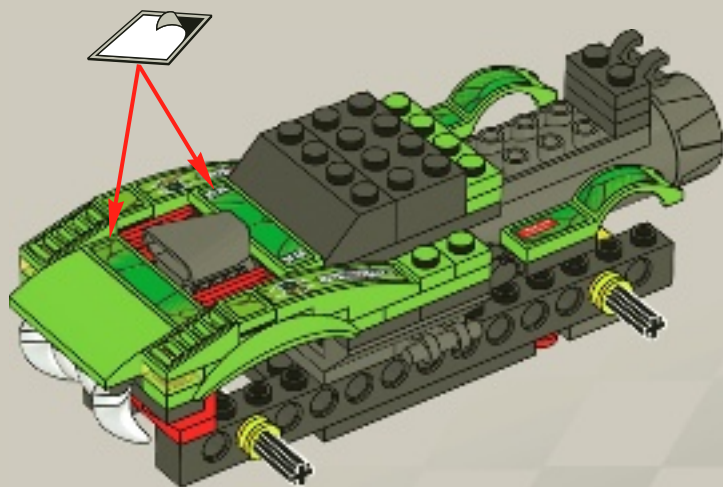

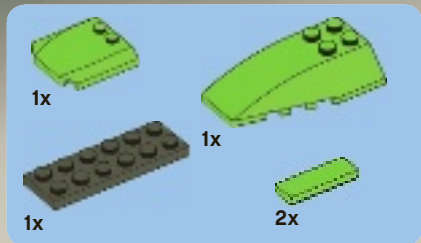
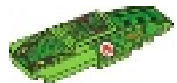

24

1

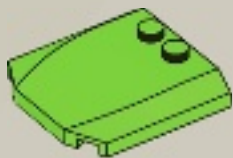

2

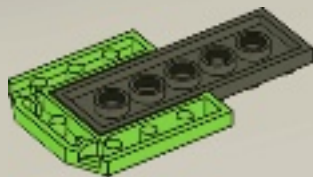

3

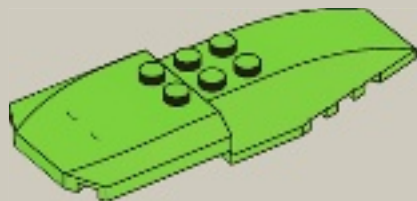

4

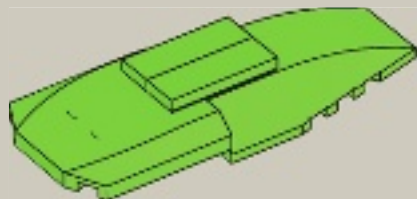

5

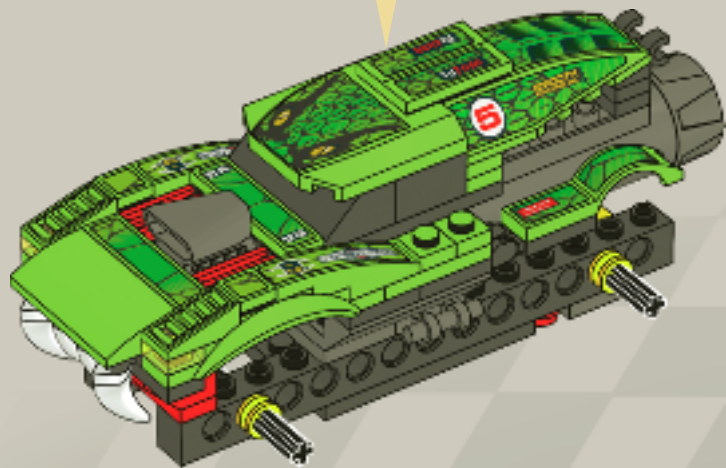
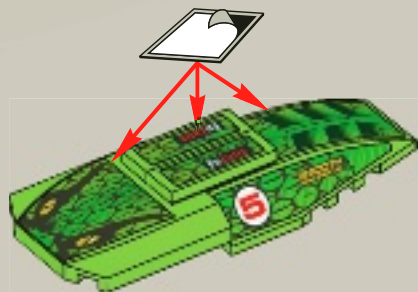



25

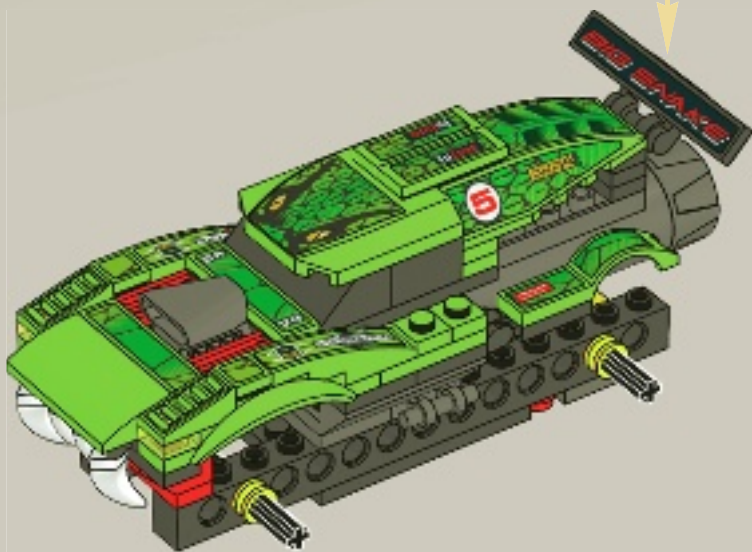

26



4x



4x

26

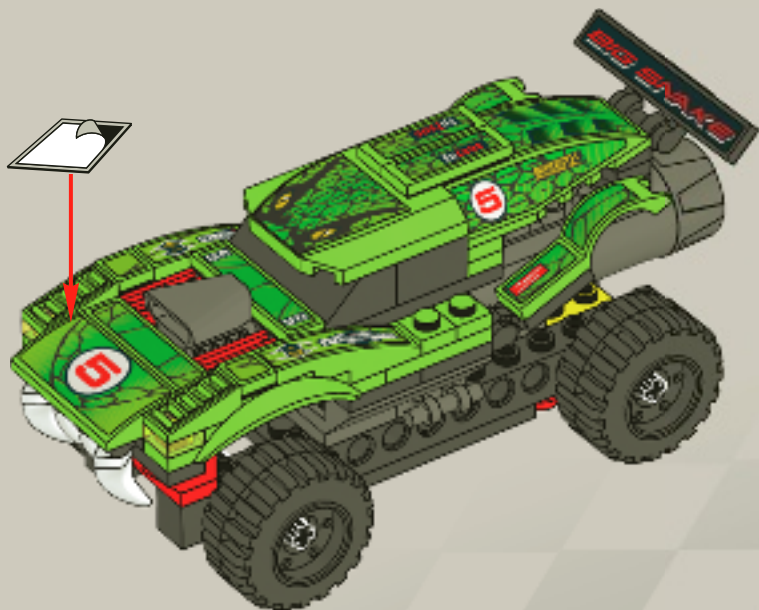



4x

27



2x

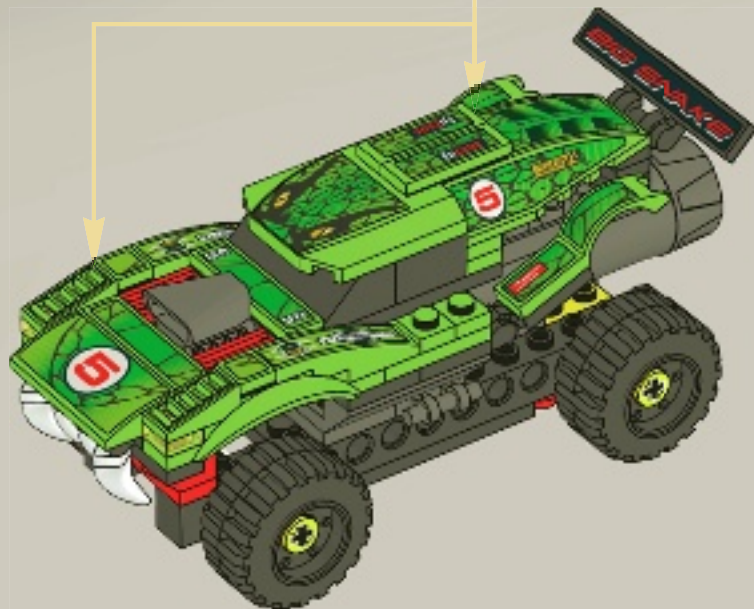

28

28

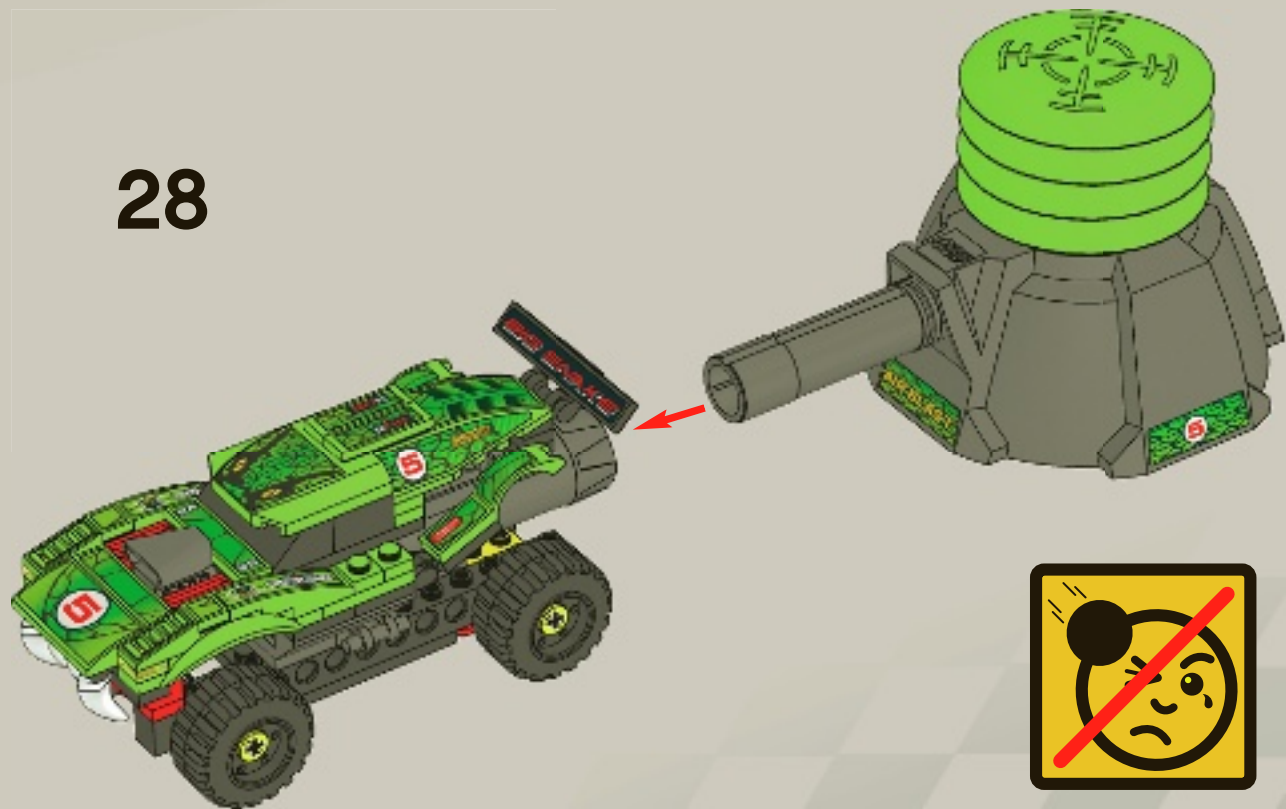



2x
366021



1x
371021



1x
4580871



2x
241221



2x
614121



2x
4566256



1x
245824



2x
370024



2x
302324



8x
4239601



1x
300126



2x
4107558



2x
4568387



1x
303726



3x
302326



1x
366626



1x
663626



2x
379526



2x
303226



4x
4550017



1x
4556158



1x
4225201



2x
4183043



2x
4183060



4x
4517737



4x
4140670



2x
370726



2x
3000844



1x
4503680



2x
4537927



2x
4537251



2x
4540385



2x
4210210



2x
4565993



2x
4164021



2x
4187743



2x
4529160



2x
4284253



1x
4597561



1x
4612424



1x
4610893



2x
4610474



3x
4211065



2x
4210660



1x
4502068



1x
4549999



1x
4210997



1x
4563226



1x
4568692



1x
4563215

8



Customer Service

Kundenservice

Service Consommateurs

Servicio Al Consumidor

www.lego.com/service or dial



00800 5346 5555 :



1-800-422-5346 :



FREE! GRATIS! GRATUIT!





club
MAGAZINE™

www.LEGOclub.com



00800 5346 5555*        

  **1-866-534-6258 • 1-877-518-5346**

US & Canada only

Canada seulement

* Freephone. Mobile charges may apply. * Numéro sans Frais. Des Frais peuvent s'appliquer avec les téléphones cellulaires. * Gebührenfrei. Kosten für Anrufe aus Mobilfunknetzen können abweichen. * Gratia telefonnummer vanaf vaste lijn. * Det er ett gratis nummer, när du ringer Pre Posttelefon. * Det är gratis, när du ringer Från en Post telefon.



VISIT THE WORLD'S
BIGGEST LEGO® SHOP!

www.LEGOshop.com

Go to www.LEGOsurvey.com/product
to fill out a survey for a chance
to win a cool LEGO® Product.

No purchase necessary.

Open to all residents where not prohibited.

www.LEGOsurvey.com/product

GEWINNE!

Nimm an der Umfrage auf
www.LEGOsurvey.com/product
teil und hab die Chance ein cooles
LEGO® Produkt zu gewinnen!

Die Teilnahme am Gewinnspiel führt zu keinerlei
Kaufverpflichtungen. Teilnahme in allen nicht
ausgeschlossenen Ländern möglich.

WIN!

Ga naar www.LEGOsurvey.com/product,
vul een enquêteformulier
in en maak kans op een
cool LEGO® product.

Geen aankoopverplichting.
Iedereen mag deelnemen, uitgezonderd
ingezetenden van landen waar een
enquêteverbod geldt.

GAGNE !

Visite www.LEGOsurvey.com/product
pour répondre à un
questionnaire et avoir une
chance de gagner un produit
LEGO® très cool !

Aucune obligation d'achat.
Ouvert à tous les résidents des pays
autorisés.

当てよう!

www.LEGOsurvey.com/product
にアクセスして、
アンケートにご記入ください。
当選者にはレゴ®製品を
差し上げます。

お買い上げの必要はありません。
禁止されていない限り、すべての皆様にご利用いただけます。