

Oriente BAZAAR



WARNING: CHOKING HAZARD.
Toy contains small parts and a small ball.
Not for children under 3 years.



3849

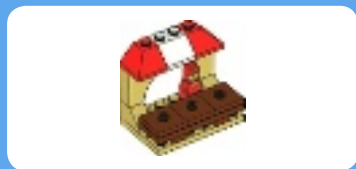
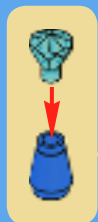

1





AVERTISSEMENT : RISQUE D'ÉTOUFFEMENT.
Le jouet contient des petites pièces ainsi qu'une petite boule.
Il ne convient pas aux enfants de moins de 3 ans.



ADVERTENCIA: PELIGRO DE ASFIXIA.
Juguete que contiene partes pequeñas y una pelota pequeña.
No recomendado para niños menores de 3 años.

2



3



4



5



6





1



2



3

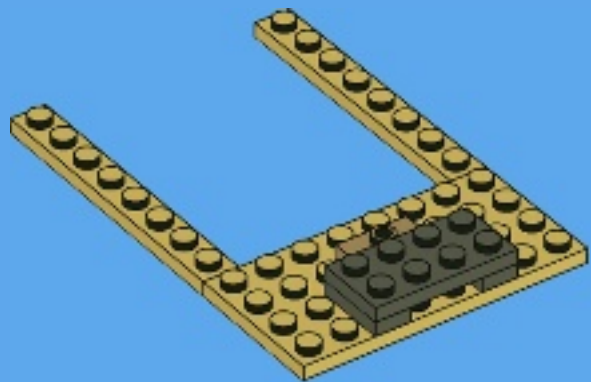

4



5

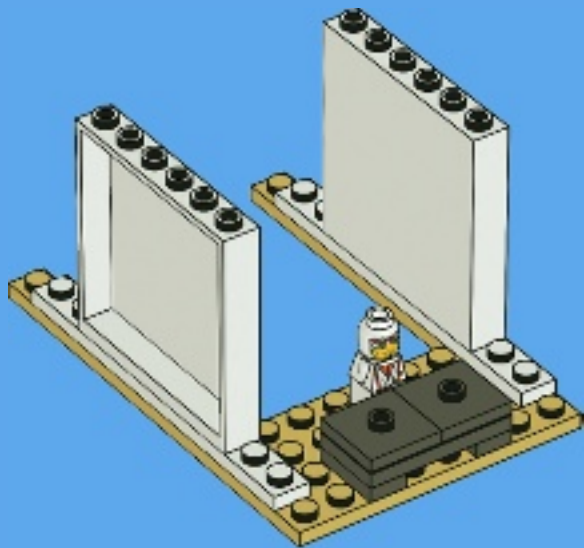

6

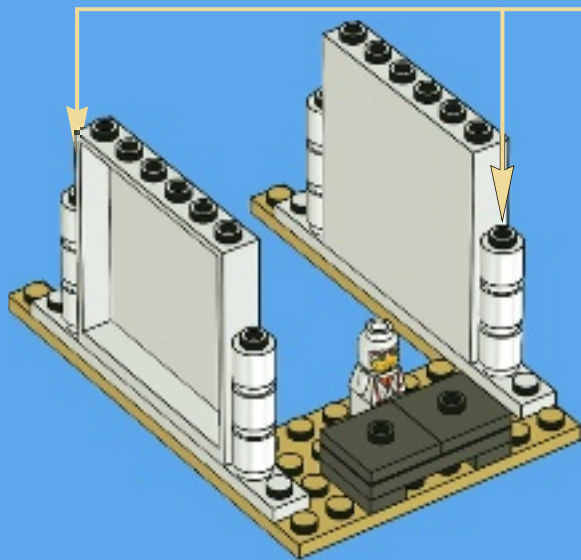

4x

7

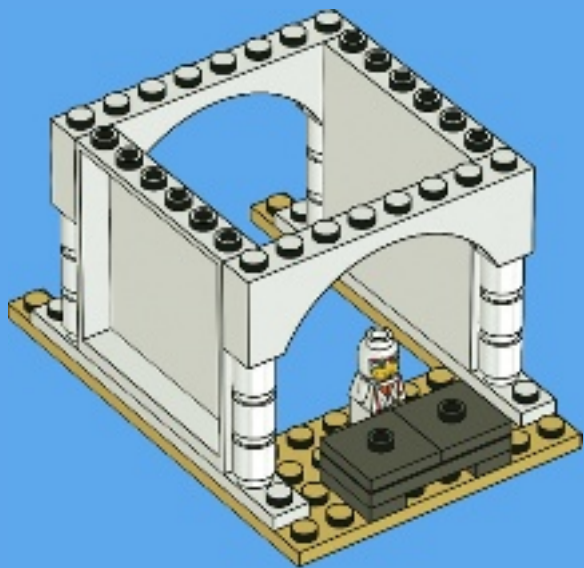

8

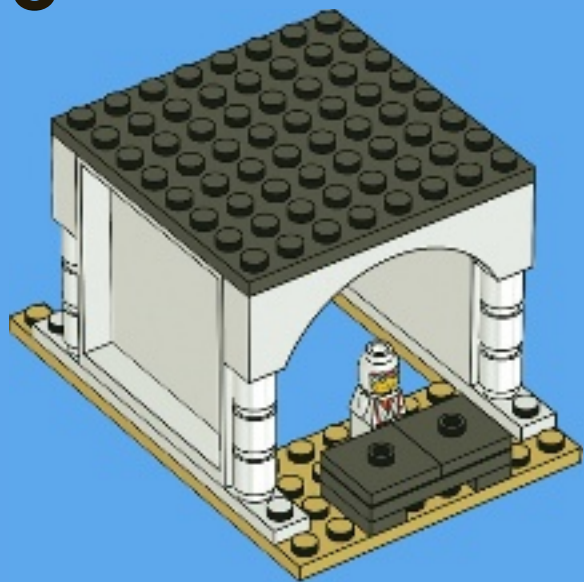

9

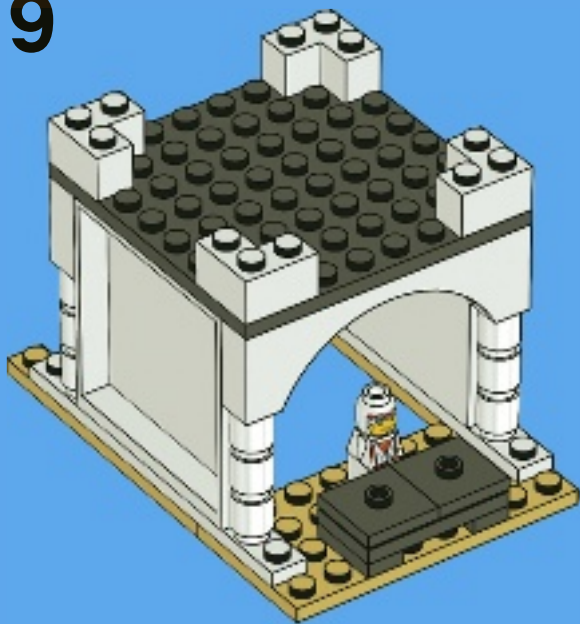

10

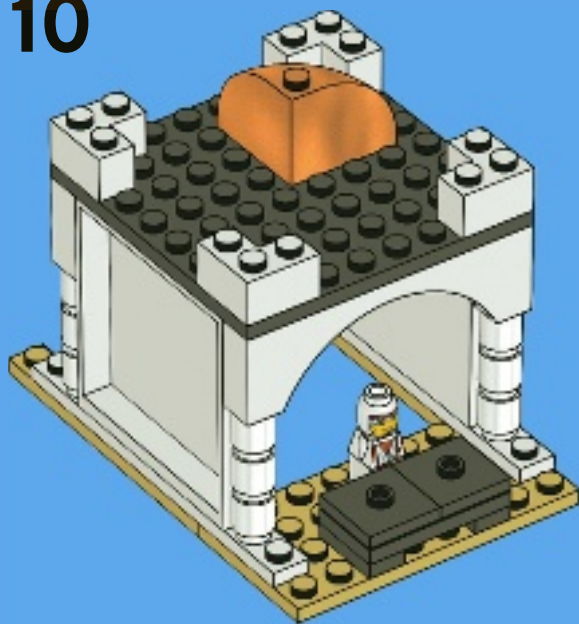

11

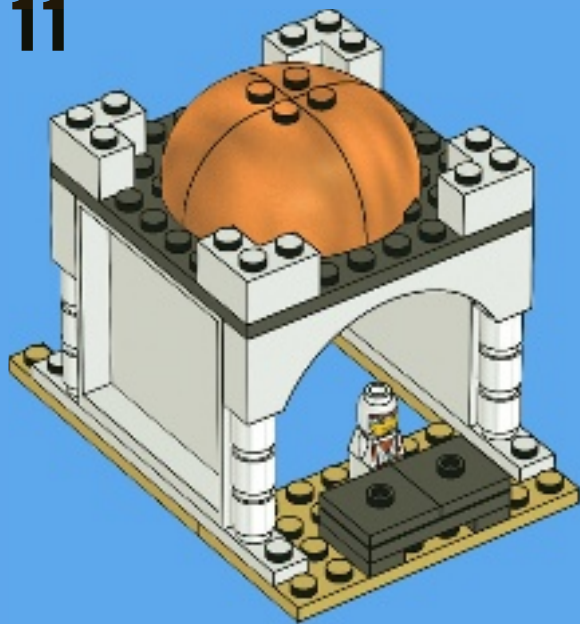

12

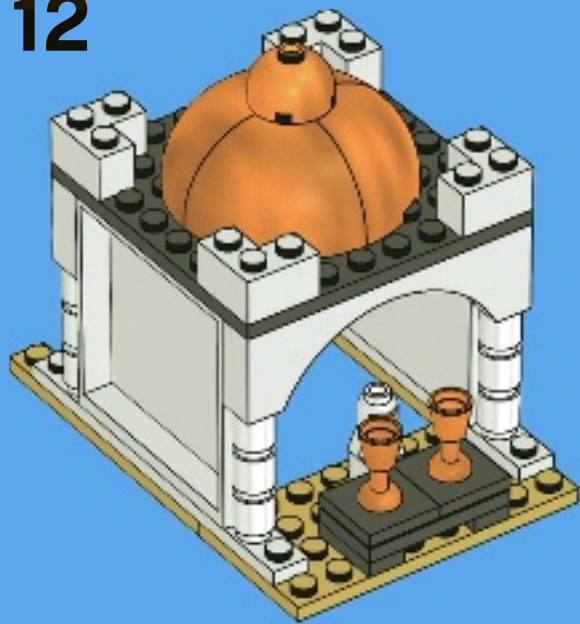





Customer Service

Kundenservice

Service Consommateurs

Servicio Al Consumidor

www.lego.com/service or dial



: 00800 5346 5555

: 1-800-422-5346



3835
Robo Champ

2-3 6+ 10-15



3836
Magikus

2-4 6+ 10-20



3837
Monster 4

2-4 7+ 15-20



3838
Lava Dragon

2-4 7+ 15-25



3839
Race 3000

2-4 7+ 20-30



3840
Pirate Code

2-4 8+ 15-25



3841
Minotaurus

2-4 7+ 20-30



3843
Ramses Pyramid

2-4 8+ 20-40



3844
Creationary

3-8 7+ 30-60

games.LEGO.com



FREE! GRATIS! GRATUIT!



club
MAGAZINE™

www.LEGOclub.com



00800 5346 5555*        

  **1-866-534-6258 • 1-877-518-5346**

US & Canada only

Canada seulement

* Freephone. Mobile charges may apply. * Numéro sans Frais. Des Frais peuvent s'appliquer avec les téléphones cellulaires. * Gebührenfrei, Kosten Für Anrufe aus Mobilfunknetzen können abweichen.
* Gratis telefoonnummer vanaf vaste lijn. * Det er ett gratis nummer, når du ringer fra Fasttelefon. * Det är gratis, när du ringer från en Fast telefon.



VISIT THE WORLD'S
BIGGEST LEGO® SHOP!

www.LEGOshop.com



WIN!

Go to www.nielsen.com/LEGO
to fill out a survey for a chance
to win a cool LEGO® Product.

No purchase necessary.

Open to all residents where not prohibited.



www.LEGO.com

www.nielsen.com/LEGO

GEWINNE!

Nimm an der Umfrage auf
www.nielsen.com/
LEGO teil und hab die Chance ein cooles
LEGO® Produkt zu gewinnen!

Die Teilnahme am Gewinnspiel führt zu keinerlei
Kaufverpflichtungen. Teilnahme in allen nicht
ausgeschlossenen Ländern möglich.

WIN!

Ga naar www.nielsen.com/LEGO,
vul een enquêteformulier in en
maak kans op een
cool LEGO® product.

Geen aankoopverplichting.
Iedereen mag deelnemen, uitgezonderd
ingezetenden
van landen waar een enquêteverbod geldt.

GAGNE !

Visite www.nielsen.com/LEGO
pour répondre à un questionnaire
et avoir une chance de gagner
un produit LEGO® très cool !

Aucune obligation d'achat.
Ouvvert à tous les résidents des pays
autorisés.

当てよう！

www.nielsen.com/LEGO
にアクセスして、
アンケートにご記入ください。
当選者にはレゴ®製品を
差し上げます。

お買い上げの必要はありません。
禁止されていない限り、すべての皆様にご利用いただけます。